

Rittal – The System.

Faster – better – everywhere.



Compact Cooling unit Compact 机柜空调

3370.22X 3370.52X
3370.32X 3370.62X
3370.37X 3370.72X
3370.42X

1194.42X 1194.55X
1194.62X 1194.72X

Assembly and operating instructions
空调装配和使用说明书

ENCLOSURES

POWER DISTRIBUTION

CLIMATE CONTROL

IT INFRASTRUCTURE

SOFTWARE & SERVICES

FRIEDHELM LOH GROUP



Contents

Contents 2

1 Application Error! Bookmark not defined.

2 Technical data..... Error! Bookmark not defined.

3 Assembly...Error! Bookmark not defined.

4 Safety notes Error! Bookmark not defined.

5 Commencing operation and control behavior.....Error! Bookmark not defined.

5.1 Controller control... **Error! Bookmark not defined.**

5.1.1 Operation of the controller..... **Error! Bookmark not defined.**

5.1.2 Editable parameters**Error! Bookmark not defined.**

5.1.3 Parameter navigation ...**Error! Bookmark not defined.**

5.1.4 Setting the target temperature **Error! Bookmark not defined.**

5.1.5 Setting the temperature range **Error! Bookmark not defined.**

5.1.6 Controller display .. **Error! Bookmark not defined.**

5.1.7 Display buttons..... **Error! Bookmark not defined.**

5.1.8 Compressor: On / Off ...**Error! Bookmark not defined.**

5.2 Alarm parameters.. **Error! Bookmark not defined.**

5.3 Evaluating system messages..... **Error! Bookmark not defined.**

5.4 Forced cooling..... **Error! Bookmark not defined.**

6 Filter mats .Error! Bookmark not defined.

7 Technical informations Error! Bookmark not defined.

7.1.1 Operation of the cooling unit **Error! Bookmark not defined.**

7.1.2 Condensate discharge .**Error! Bookmark not defined.**

8 Handling instructions .. Error! Bookmark not defined.

8.1 Fitting the cooling unit ..**Error! Bookmark not defined.**

8.1.1 External mounting of the cooling unit **Error! Bookmark not defined.**

8.1.2 Partial internal mounting of the cooling unit (accessories not included)..... **Error! Bookmark not defined.**

8.2 Electrical connection.... **Error! Bookmark not defined.**

8.2.1 Connection data.... **Error! Bookmark not defined.**

8.2.2 Overvoltage protection and power line load**Error! Bookmark not defined.**

9 Scope of supply and guarantee... Error! Bookmark not defined.

9.1 Compressed air cleaning**Error! Bookmark not defined.**

10 Storage and disposal .. Error! Bookmark not defined.

11 Scope of supply and guarantee . Error! Bookmark not defined.

12 Wire plan **13**

1 Application

1 Application

Enclosure cooling units are designed and built to dissipate heat from enclosures by cooling the air inside the enclosure and protecting temperature sensitive components.

2 Technical data

See nameplate

3 Assembly

The standard wall-mounted unit is suitable for external mounting. Cut out the sections and drill according to the drawing.

Cut the enclosed seals to the required length and attach to the unit. Screw tapped pins into the blind nuts on the rear of the unit. The unit is then to be secured using washers and nuts

4 Safety notes

The following safety notices are to be observed in their entirety for the correct use of the equipment:

- To prevent the enclosure with the cooling unit fitted tipping over, it is essential that this be bolted to the floor.
- A roller door is to be used to ensure problem free opening and closing of the enclosure door.
- A transportable enclosure with built-in cooling unit may only be produced if an additional transport anchorage to support the cooling unit is used.
Prior to mounting, ensure that:
 - the site for the enclosure, and hence the arrangement to the cooling unit, is selected so as to ensure good ventilation;
 - the location is free from excessive dirt and moisture,
 - the cutout for air extraction is located in the upper area of the enclosure;
 - the mains connection ratings, as stated on the rating plate, are available;
 - the ambient temperature does not exceed +50°C;
 - The packaging shows no signs of damage. Traces of oil on damaged packaging are an indication of refrigerant loss and of leakage in the unit system. Any damage to the packaging may be the cause of subsequent malfunctions:
- the enclosure is sealed on all sides Condensation will occur if the enclosure is leaky;
- the separation of the units from one another and from the wall should not be less than 200mm;
- air inlet and outlet are not obstructed on the inside of the enclosure;
- units are only fitted horizontally in the specified position Max. deviation from the true horizontal: 2°
- condensate drainage is provided
- electrical connection and repair are carried out only by authorized personnel

- Use only original replacement parts and accessories.
- Losses from the components installed in the enclosure must not exceed the specific refrigeration capacity of the cooling unit itself;
- The customer may not modify the cooling unit in any way.

5 Commencing operation and control behavior

Following the completion of mounting and a waiting period of approximately 30 minutes (to allow oil to collect in the compressor in order to ensure lubrication and cooling).

5.1 Controller control

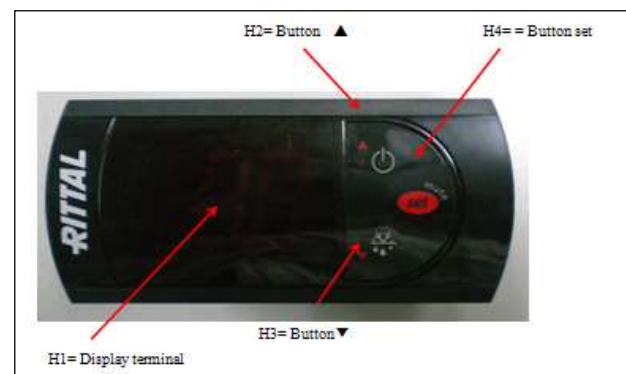

Figure 1: Controller

After electrical connection the internal fan turns on and circulates the enclosure air. This helps assure even temperature distribution within the enclosure. The condenser fan and compressor are controlled by the controller. The minimum time is 3 minutes to restart the compressor after it has switched off. The switching difference is 5 K. To avoid short switching cycles and hence the danger of inadequate or only partial cooling in some sections of the enclosure, the switching difference should be set to be only as low as necessary. For economic reasons (energy saving), the nominal value of the internal enclosure temperature T_i should also be set to be only as low as necessary.

5.1.1 Operation of the controller

The display terminal H1 consists of a 3 position 7-segment display which indicates the internal enclosure temperature in °C as well as any fault codes. The actual enclosure internal temperature is constantly displayed on H1. When a system message is generated, this alternates in the display with the current internal enclosure temperature.

5 Commencing operation and control behavior

5.1.2 Editable parameters

Param. Type	Display screen	Parameter	Min. value	Max. value	Factory setting	Description
F	PS	Password	0	99	22	Protection code for modifying the configuration parameters (default=22). The value of the password can be customized from the supervisor
S	St	Setpoint	r1	r2	35	:r1 minimum value and r2 maximum value of the set point. Parameter St determines the desired temperature to be maintained inside the cabinet or cold room (set point).
F	rd	Regulation differential	0	+19	5	Value that is added to (or subtracted from, in 'reverse' mode) the temperature set point. <i>rd= low values:</i> <ul style="list-style-type: none"> more precise temperature control; high compressor On/Off switching frequency in the event of minimum. Temperature deviations (with the risk of causing damage). <i>rd= high values:</i> <ul style="list-style-type: none"> less precise temperature control; low compressor On/Off switching frequency in the event of minimum temperature deviations. Important: the compressor can also be safeguarded using the parameters that limit the number of activations/hour and the minimum off time
C	r1	Setpoint min. value	20	r2	30	r1 & r2 :set the range of temperatures for setting the set point.
C	r2	Setpoint max. value	r1	50	45	
C	cc	Continuous cycle period	0	15	1 (hours)	?
C	A0	Alarm and fan differential	-20	+20	2	See chapter 5.2
F	AH	Alarm maximum temp.	-50	+99	10	See chapter 5.2
C	Ad1	Delay for high and low temp. alarm	0	199	30	Delay for high temperature alarm when power on just before. When alarm condition is achieved but power on just before, the timer start to count for a specify value (Ad1). Only the time elapsed, alarm relay can be active

5.1.3 Parameter navigation

The operating parameters, modifiable using the keypad, are divided into two types: frequent (type F) and configuration (type C). Access to the latter is protected by password (default= 22) to prevent accidental or unauthorized modifications.

Accessing the type F parameters:

- Press the SET button for more than 3 s (if there are active alarms, mute the buzzer), the display shows the parameter code 'PS' (password);
- use the UP and DOWN buttons to scroll the parameters. The LED corresponding to the category of parameters will be on (see parameters list)
- press SET to display the value associated with the parameter increase or decrease the value using the UP or DOWN button respectively;
- press SET to temporarily save the new value and display the parameter again; repeat the procedure for any other parameters that need to be modified;
- press the SET button for more than 3 s to permanently save the parameters and exit the parameter setting procedure.

5 Commencing operation and control behavior

Accessing the type C parameters:

- Press the SET button for more than 3 s (if there are active alarms, mute the buzzer), the display shows the parameter code "PS" (password);
- press the SET button to access the password setting; use the UP and DOWN buttons to scroll the numbers until displaying "22" (password to access the parameters);
- press the SET button to confirm the password ;
- use the UP and DOWN buttons to scroll the parameters. The LED corresponding to the category of parameters will be on (see Below Table);
- press SET to display the value associated with the parameter increase or decrease the value using the UP or DOWN button respectively;
- press SET to temporarily save the new value and display the parameter again;
- repeat the procedure for any other parameters that need to be modified;
- press the SET button for more than 3 s to permanently save the parameters and exit the parameter setting procedure.

Accessing the type S parameters:

- press SET for 1 s, the set value will start flashing;
- increase or decrease the value using UP or DOWN;
- press SET to confirm the new value.

5.1.4 Setting the target temperature

The temperature is preset at the factory to 35°C.

- press SET for 1 s, the set value will start flashing;
- increase or decrease the value using UP or DOWN;
- press SET to confirm the new value.

5.1.5 Setting the temperature range

- Press the SET button for more than 3 s (if there are active alarms, mute the buzzer), the display shows the parameter code "PS" (password);
- press the SET button to access the password setting; use the UP and DOWN buttons to scroll the numbers until displaying "22" (password to access the parameters);
- press the SET button to confirm the password; use the UP and DOWN buttons to scroll the parameters.
- press SET to display the value associated with the parameter increase or decrease the value using the UP or DOWN button respectively;
- press SET to temporarily save the new value and display the parameter again;
- repeat the procedure for any other parameters that need to be modified;
- press the SET button for more than 3 s to permanently save the parameters and exit the parameter setting procedure.



Notice!
It is not allowed to change the value for „r1 & r2“ without Rittal authorization

5.1.6 Controller display

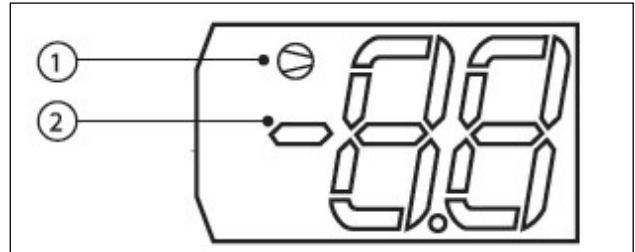



Figure 2: Controller display

no.	function	Normal operation			Start up
		on	off	flash	
1	compressor	on	off	call	on
2	digits	two digits with sign and decimal point, -99 to 99(*).			



Notice!
The parameters that feature three digit values can be set from the supervisor. In this case the display will show "___"

5.1.7 Display buttons

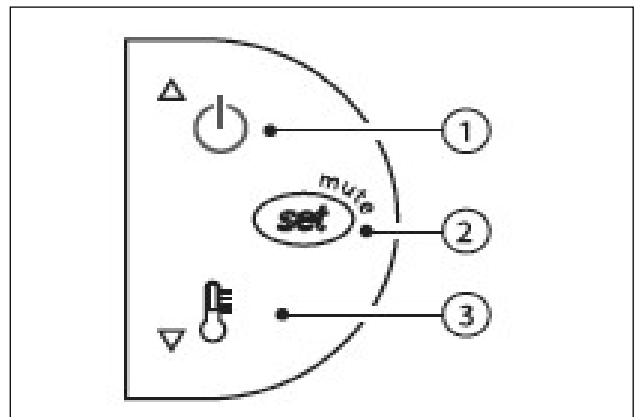

Figure 3: Display buttons

no.	Normal operation	Start up/ reset	
	Pressing the button alone		
1	more than 3 s: switch the compressor ON/OFF	-	
2	<ul style="list-style-type: none"> ▪ 1 sec: displays/sets the set point ▪ more than 3 sec.: accesses the parameter setting menu (enter password 22) ▪ mutes the audible alarm (buzzer) 	-	pressed together (2 and 3) activate parameter reset procedure
Start up/ reset to factory setting parameters			
<ul style="list-style-type: none"> ▪ Disconnect power supply 			

5 Commencing operation and control behavior

- Reconnect power supply while holding buttons 2 and 3
- Display will show the message "CF"
- After a few seconds the unit will restart with factory setting parameters

8 Handling instructions

5.1.8 Compressor: On / Off

Switching the compressor ON: press UP for more than 3 s (when pressing the button, the display shows ON).

Switching the compressor OFF: press UP for more than 3 s. The display shows the message "OFF".

In OFF status, the following functions are disabled (if featured by the model):

- compressor control
- duty setting
- continuous cycle

5.2 Alarm parameters

A0: Alarm temperature differential

This represents the differential used to activate the high temperature alarm ("AH"). In the event of an alarm, as seen in the figure, the value of "A0" determines the actual activation of the temperature alarm. The value of "A0" (negative or positive) defines the nature of alarm "AH" (absolute or relative):

- $A0 \leq 0 \rightarrow$ AH expressed as absolute
- $A0 > 0 \rightarrow$ AH expressed relative to the set point

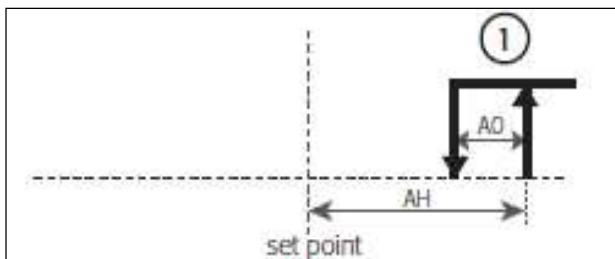

Figure 4: High temperature alarm

AH: High temperature alarm

AH setting: 10 degrees is the factory setting (-50 to 99 is the lower and upper limit). Other Factory settings: Setpoint (ST) = 35°C; A0 = 2°C.

For example: If the internal temperature of the cabinet is $T_i = 46^\circ\text{C}$, $ST (35^\circ\text{C}) + AH (10^\circ\text{C}) = 45^\circ\text{C}$, so $46^\circ\text{C} > 45^\circ\text{C}$ the display will show AH-alarm. As long as T_i is more than 43°C the display will show AH-alarm, because $ST (35^\circ\text{C}) + AH (10^\circ\text{C}) - A0 (2^\circ\text{C}) = 43^\circ\text{C}$. If the temperature T_i will fall to 42°C the alarm AH will no longer be shown in the display. As long as the temperature inside of the cabinet will not rise over 45°C again there will be no AH-alarm displayed.

Temperature alarm output

- Logo and buzzer on display: The information "AH" and logo will be shown on the display and buzzer.
- The over temperature message may also be polled via a contact on the connection clamp of the cooling unit (system message relay with changeover contact, see connection diagrams).

--Terminal "1" C (connection of the supply voltage to the fault signal relay)

--Terminal "2" NO (normally open).



Notice!

Delay for high temperature alarm when power ON: When alarm condition is achieved but power is ON, the timer start to count for a specify value (Ad1). Alarm relay becomes active when this time is elapsed.



Notice!

The unit of parameter "Ad" is "Sec".
The unit of parameter "Ad1" is "Min".



Notice!

The contacts of the relays are normally open (NO). If the alarm occurs the contacts close (NC).

HP: High pressure alarm output

- Logo and buzzer on display: The information "HP" and logo will be shown on the display and buzzer.
- The over temperature message may also be polled via a contact on the connection clamp of the cooling unit (system message relay with changeover contact, see connection diagrams).

--Terminal "1" C (connection of the supply voltage to the fault signal relay)

--Terminal "2" NO (normally open).



Notice!

Delay for high temperature alarm when power ON: When alarm condition is achieved but power is ON, the timer start to count for a specify value (Ad1). Alarm relay becomes active when this time is elapsed.



Notice!

The unit of parameter "Ad" is "Sec".
The unit of parameter "Ad1" is "Min".



Notice!

The contacts of the relays are normally open (NO). If the alarm occurs the contacts close (NC).

5.3 Evaluating system messages

Display screen	Buzzer	Alarm relay	System message	Measures
----------------	--------	-------------	----------------	----------

8 Handling instructions

E0	Active	Not active	Ambient temperature probe broken	Check sensor cable and replace if necessary
HI	Active	Active	High temperature alarm	Check cooling capacity/check unit
HP	Active	Active	High pressure alarm	Switch off unit and clean/wash the air filter

The R134a (CH₂FCF₃) refrigerant is free from chlorine. It has an ozone destroying potential (ODP) of 0 and is therefore environmentally friendly. A filter dryer which is integrated in the hermetically sealed cooling circuit, provides effective protection against moisture, acid, dirt particles, and foreign bodies within the cooling circuit.

5.4 Forced cooling

The continuous cycle is used to maintain refrigeration forced cooling mode active in the cabinet or cold room, regardless of the temperature inside the unit. This may be useful for rapidly bringing the temperature below the set point value.

To activate or deactivate the continuous cycle from the keypad, Press UP+DOWN for more than 3 s, the display shows "cc" and the icon flashes (2 flashes, pause). The unit starts the forced cooling mode at least after the minimum compressor off time (3 min.). The forced cooling mode is activated after the start for 1 h. After this time the unit starts normal operation.

6 Filter mats

The stainless steel filter mat available as an accessory is coarse and filters large dust particles or fluff from the air. Subject to the suction of the blower being high enough, fine dust is blown through the filter mat and the external circuit of the unit. This does not affect the unit's operation.

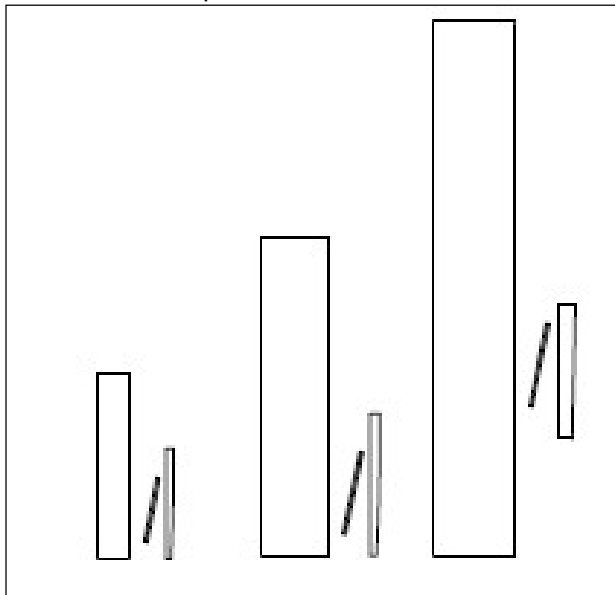

Figure 5: Replacement of the filter mat

7 Technical information

The cooling unit (compressor refrigeration unit) consists of four main components: the coolant compressor, evaporator, condenser, and the capillary, which are connected by suitable Pipe-work. This circuit is filled with a readily boiling substance, the refrigerant.

7.1.1 Operation of the cooling unit

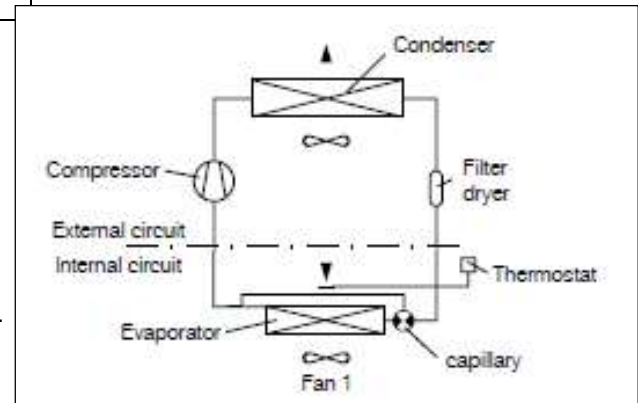
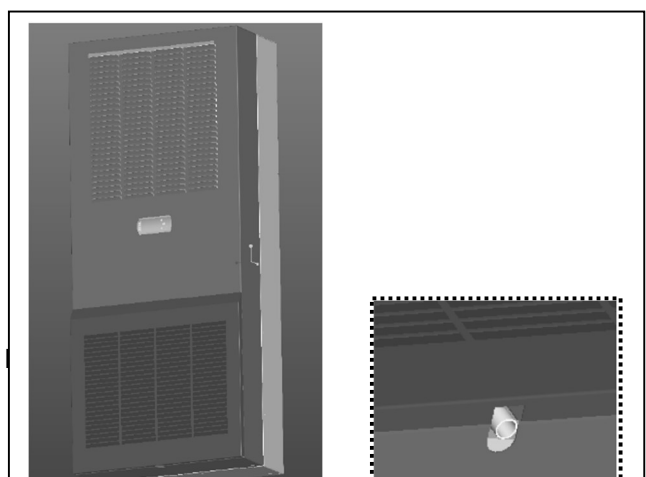

Figure 6: Operation of the cooling unit

The compressor takes the gaseous refrigerant from the evaporator and compresses it to a higher pressure in the condenser. During this process the temperature of the refrigerant rises above the ambient temperature and heat can be dissipated to the environment via the surface of the condenser. Then the refrigerant is liquefied and, by means of a thermostatically controlled capillary, returned to the evaporator, where it evaporates at low pressure. The heat required for complete evaporation is drawn from the enclosure interior causing it to cool down. The cooling cycle is thus completed, the aforementioned process of the heat transfer starts afresh.

7.1.2 Condensate discharge

A drain pipe fitted to the evaporator divider panel ensures that any condensate which may form on the evaporator (at high air humidity, low temperatures inside the enclosure) is drained away from the bottom of the unit. For this purpose, a length of hose should be fitted to the condensate pipe connection piece. The condensate must be able to run off freely. If the condensate is to be drained off over a greater distance, then care must be taken that the hose is free from kinks and a check for correct drainage made.



8 Handling instructions

8 Handling instructions

8.1 Fitting the cooling unit

The enclosure cooling unit may optionally be externally mounted on the enclosure (1) or partially internally mounted (2).

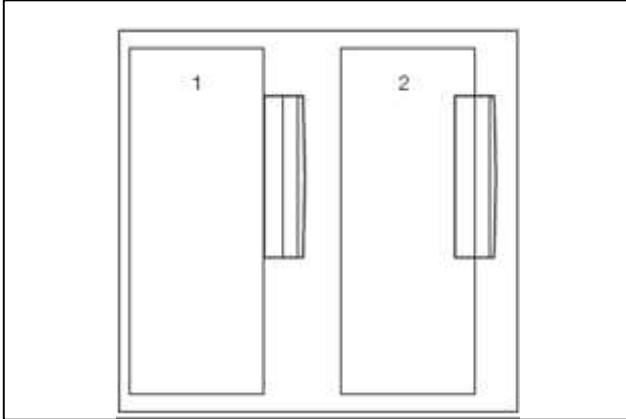

Figure 7: Installation method

To this end, cut the side panel or door of the enclosure, as per the Manu included with the supply, and drill the relevant holes.



Notice!

For mounting the units SK 3370724 in the TS side panel or rear panel, we recommend the use of enclosure panel fasteners TS 8800.071 (see RITTAL Catalogue).

8.1.1 External mounting of the cooling unit

- Cut the supplied sealing tape to the correct length and stick it carefully along the back of the unit so that no gaps are left at the joints.

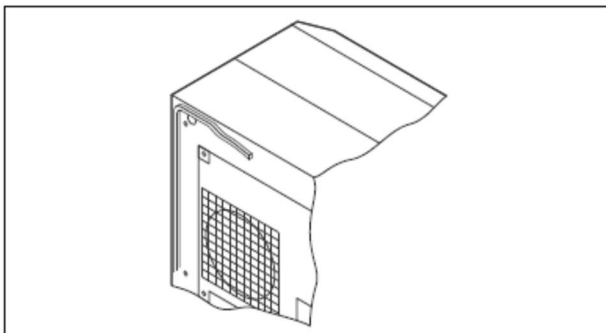

Figure 8: Applying the self-adhesive tape

- Screw the supplied grub screws into the blind nuts on the rear of the unit.
- Secure the unit using the supplied washers and nuts.

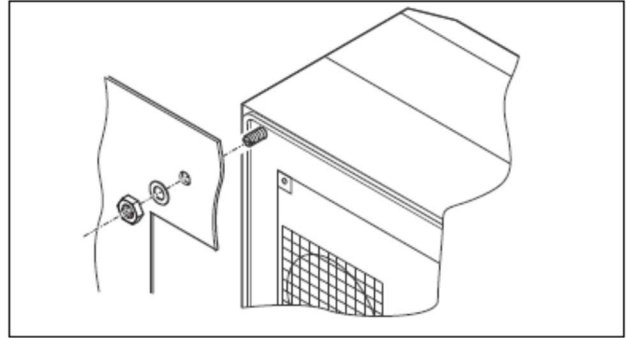

Figure 9: Securing the unit (all compact units except 3370220)

8.1.2 Partial internal mounting of the cooling unit (accessories not included)

- Fix the 4 mounting bars on the air conditioner by using screws.

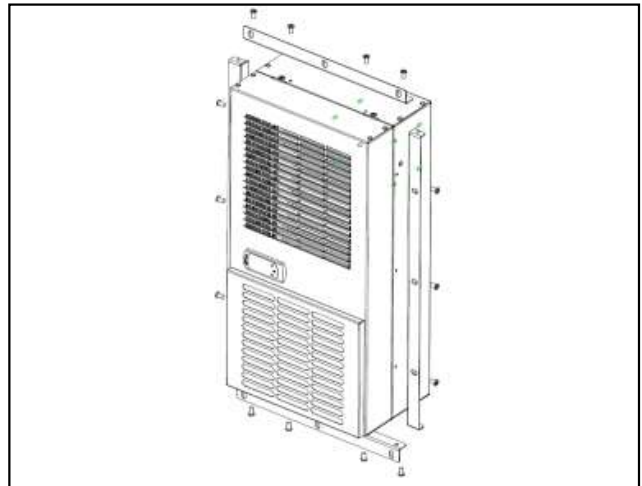

Figure 10: Fixing mounting bars

- Cut the supplied sealing tape to the correct length and stick it carefully along the inside of the rear enclosure half so that no gaps are left at the connection points.

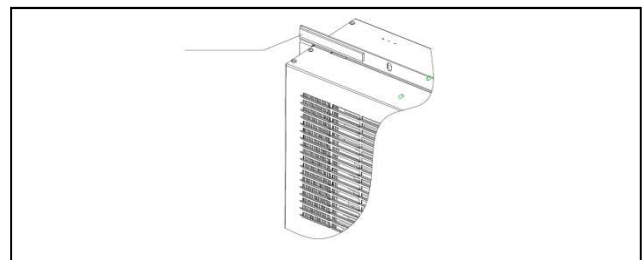

Figure 11: Sticking sealing tape

- Mount the front enclosure tray using the washers and nuts.

8 Handling instructions

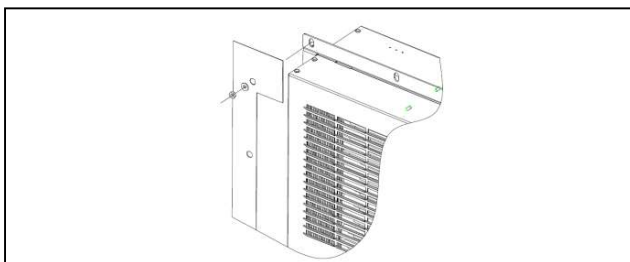

Figure 12: Mounting cooling units

8.2 Electrical connection

When performing electrical installation, shall comply with national and local institute There are existing regulations and provisions of the local power supply bureau. Electrical safety. Installed by qualified electrician, electrician must comply with the current standards and regulations. Connect the power supply cable according to the power supply tension as shown on the name plate by following the instructions below:

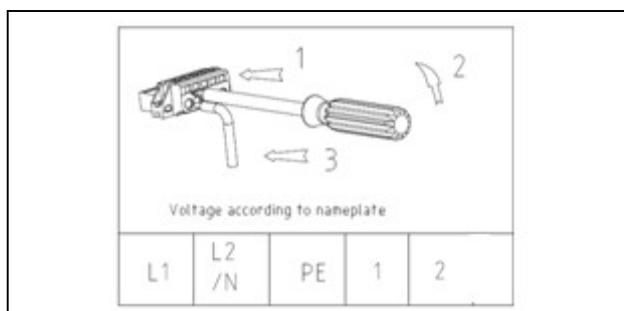

Figure 13: Electrical connection

Type	Power Input
SK 3370220	L1-N
SK 3370320	L1-N
SK 3370370	L1-N
SK 3370420	L1-N
SK 3370424	L1-L2
SK 1194420	L1-N
SK 1194424	L1-L2
SK 3370520	L1-N
SK 3370524	L1-L2
SK 1194550	L1-N
SK 1194554	L1-L2
SK 3370620	L1-N
SK 1194620	L1-N
SK 3370724	L1-L2
SK 1194724	L1-L2

8.2.1 Connection data

- The connected voltage and frequency must correspond to the values stated on the rating plate
- The cooling unit must be connected to the mains via an all-pin isolating device, which ensures at least 3 mm contact opening when switched off

- No additional temperature control may be connected upstream of the unit at the supply end
- Install the pre-fuse specified on the rating plate to protect the cable and equipment from short-circuits
- The mains connection must ensure low-noise

8.2.2 Overvoltage protection and power line load

- The unit does not have its own overvoltage protection. Measures must be taken by the operator at the supply end to ensure effective lightning and overvoltage protection. The mains voltage must not exceed a tolerance of $\pm 10\%$.
- In accordance with IEC 61 000-3-11, the unit is intended solely for use at sites with a continuous current-carrying capacity (incoming mains power supply) of more than 100 A per phase and with a supply voltage of 400/230 V. If necessary, the electricity supply company must be consulted to ensure that the continuous current-carrying capacity at the point of connection to the public grid is sufficient for connection of such a unit.
- The fans and compressors in single- and three phase units are intrinsically safe (thermal winding protection). This also applies to transformer versions, types 3370.424, 1194.424, 3370.524, 1194.524, 3370.724, 1194724 and to special-voltage units which are likewise equipped with a transformer.
- Install the slow pre-fuse specified on the rating plate (miniature circuit-breaker with appropriate characteristic – e.g. “K” characteristic – or gG standard type slow fuse, circuit-breaker for plant or transformer protection) to protect the cable and equipment from short-circuits. Select a suitable circuit-breaker in accordance with the information specified on the rating plate: Set it to the minimum specified value. This will achieve the best short-circuit protection for cables and equipment. Example: Specified setting range 6.3 – 10 A; set to 6.3 A.

9 Inspection and maintenance



Risk of electric shock!

The unit is live.

Switch off the power supply before opening, and take suitable precautions against it being accidentally switched back on.

The cooling circle is designed in the form of a maintenance-free, hermetically sealed system. The cooling unit is filled with the required quantity of refrigerant at the factory, checked for leaks, and subjected to a functional test run.

The installed maintenance-free fans are mounted on ball bearings, protected against moisture and dust. The life expectancy is at least 30,000 operating hours. The cooling unit is thus largely maintenance-

9 Inspection and maintenance

free. All that may be required from time to time is to clean the components of the external air circuit using a vacuum cleaner or compressed air if they become visibly dirty. Any stubborn, oily stains may be removed using a non-flammable detergent, such as degreaser. Maintenance interval: 2,000 operating hours. Depending on the level of contamination in the ambient air, the maintenance interval may be reduced to suit the air pollution intensity.



Notice!
Caution!
Risk of fire!
Never use flammable liquids for cleaning.



Figure 15: Twist off the screw on the top of the cover

Sequence of maintenance measures:

- Check the level of dirt.
- Filter soiling? Replace the filter if necessary.
- Cooling membranes soiled? Clean if necessary.
- Activate test mode; cooling function OK?
- Check noise generation of compressor and fans.



Caution!
Risk of fire!
Never use flammable liquids for cleaning.



Figure 16: Twist off the screw on the bottom of the cover

Sequence of maintenance measures:

- Check the level of dirt.
- Filter soiling? Replace the filter if necessary.
- Cooling membranes soiled? Clean if necessary..
- Check noise generation of compressor and fans.

9.1 Compressed air cleaning



Figure 14: Break power



Figure 17: Open the cover

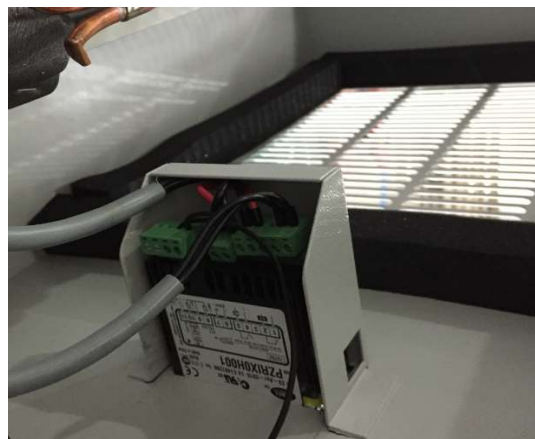

Figure 18: Disconnect the plug of the display

9 Inspection and maintenance



Figure 19: Twist off the screw of the outside fan(1)



Figure 22: Disconnect the plug of the outside fan(1)



Figure 20: Twist off the screw of the outside fan(2)

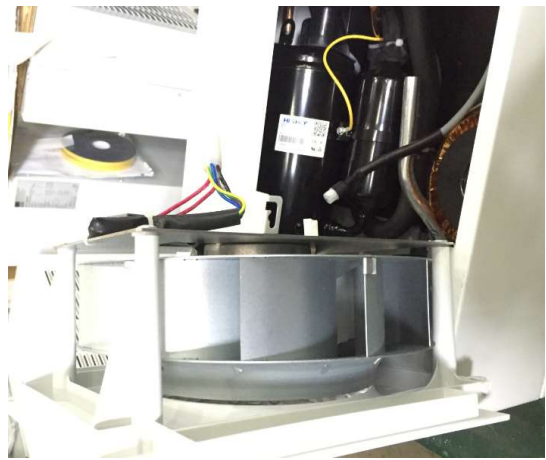

Figure 23: Disconnect the plug of the outside fan(2)



Figure 21: Remove the outside fan

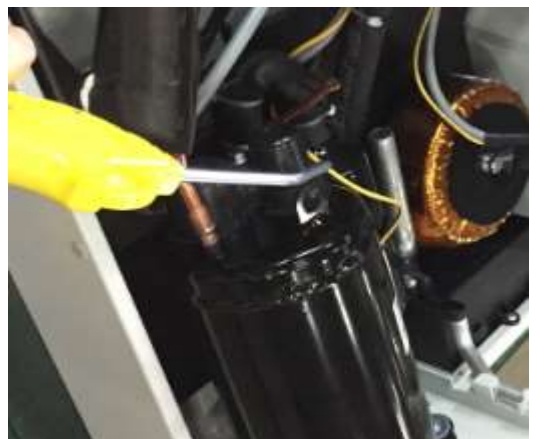

Figure 24: Clean the heat pipe and compressor chamber using compressed air

9 Inspection and maintenance

Figure 25: Clean the heat exchanger using compressed air



10 Storage and disposal



Caution! Risk of damage!
The cooling unit must not be subjected to temperatures above +70°C during storage.

Store the cooling unit in the appropriate position for transport.

The closed cooling cycle contains refrigerant and oil, which must be properly disposed of for the protection of the environment. Facilities for disposal are available at the Rittal plant.

Please contact us for advice.

11 Scope of supply and guarantee

1 cooling unit, ready for connection

1 sealing tape

1 set of mounting and operating instructions

Guarantee:

This unit is covered by a 1-year guarantee from the date of supply, subject to correct usage (see also Safety notices under heading 4.). Within this period, the returned unit will be repaired in the factory or replaced free of charge. The cooling unit is to be used for the cooling of enclosures only. If it is connected or handled improperly the manufacturer's guarantee does not apply and in this case we are not liable for any damage caused.

12 Wire plan

12 Wire plan

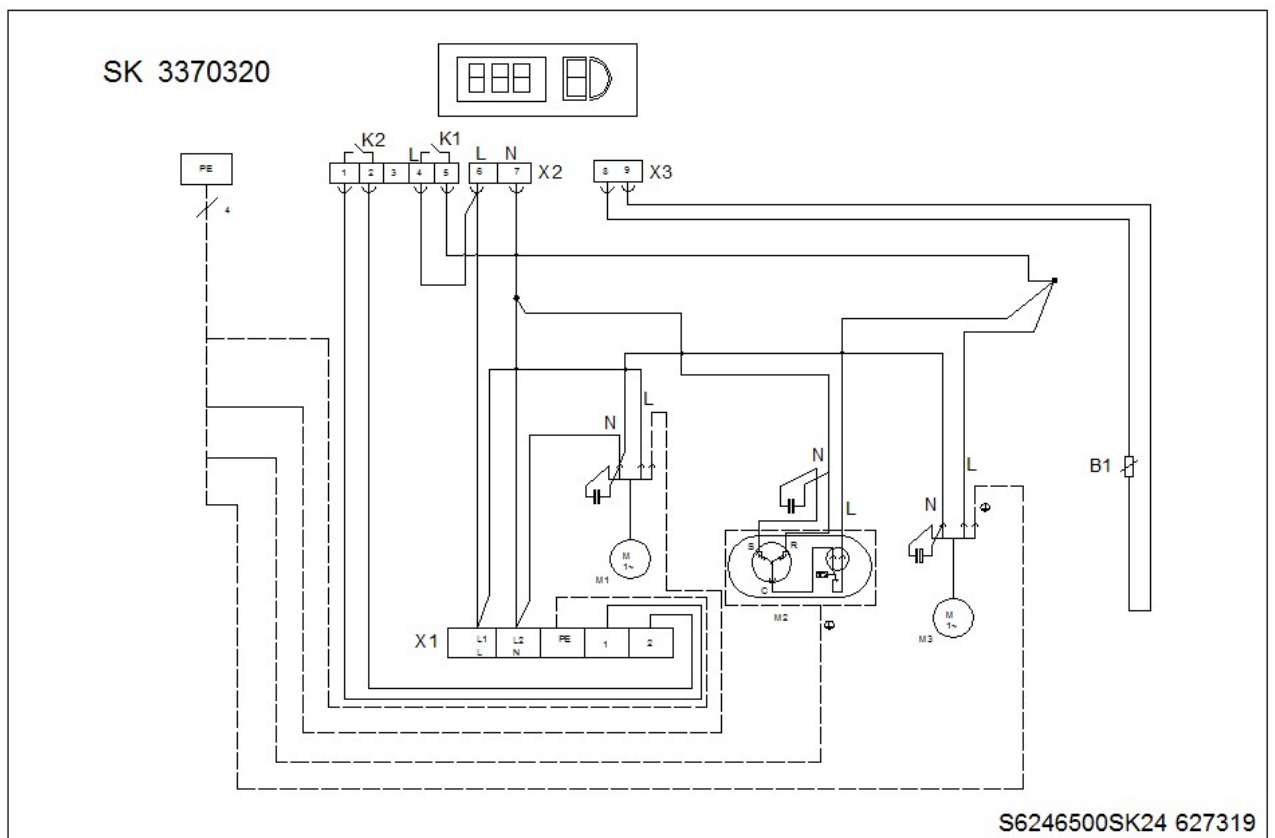
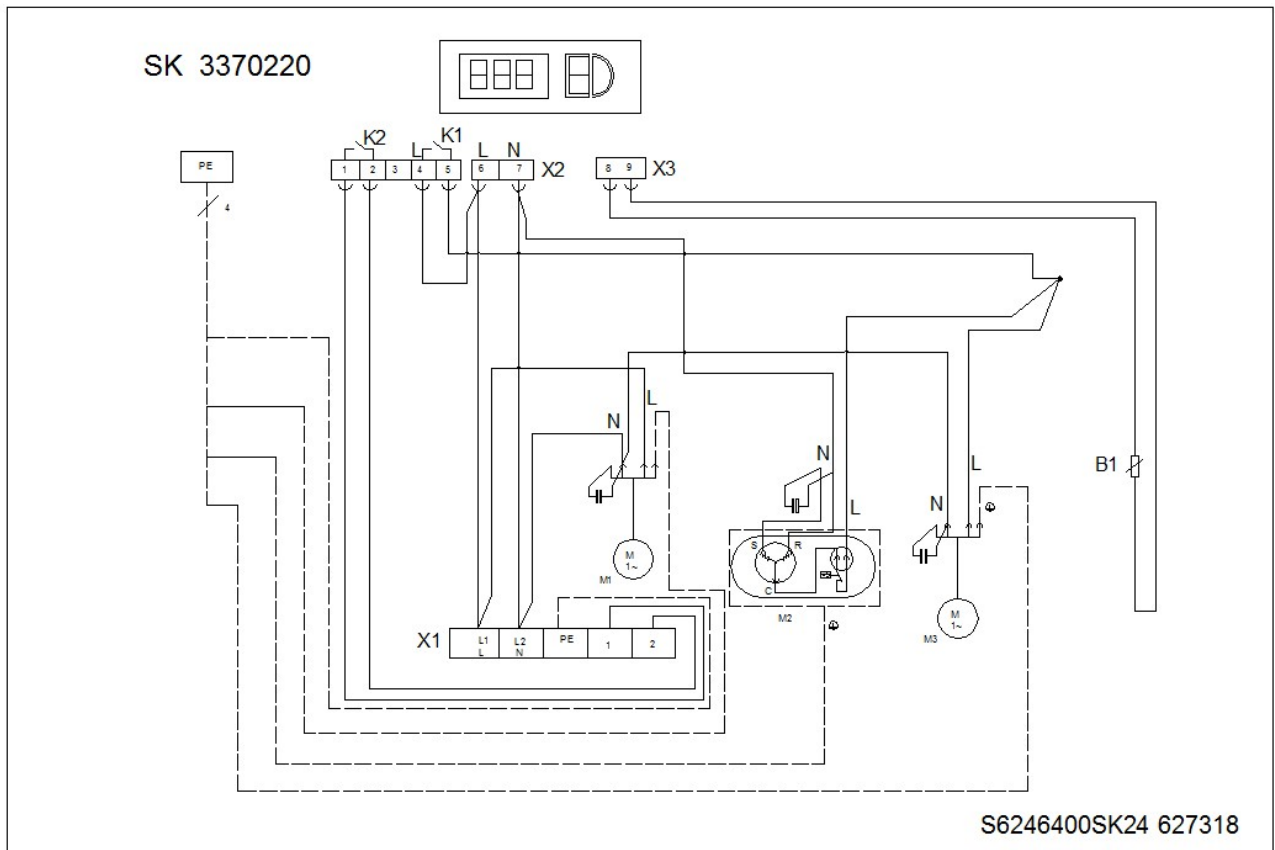

12 Wire plan

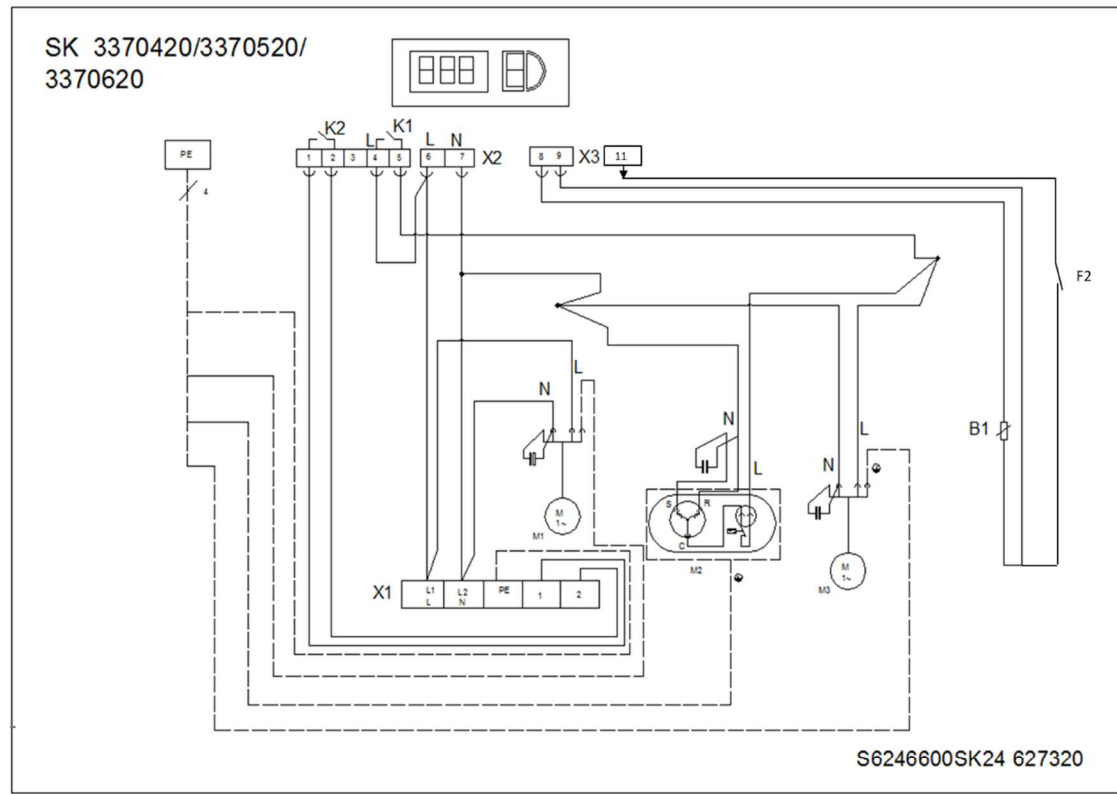

SK 3370724:

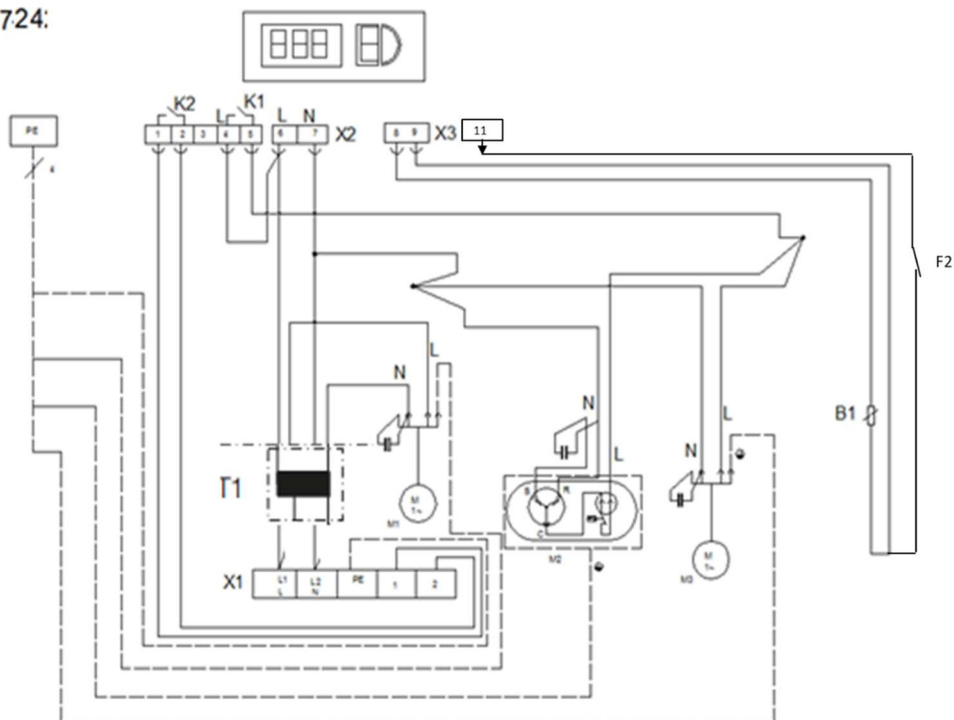

X2 Power Connector On Display
X3 Connector On Display
X1 Power supply W30 terminal on panel
M1 Evaporator Fan
M2 Compressor

M3 Condenser Fan
B1 NTC internal Probe NTC
K1 Relay for compressor & condenser fan
K2 Relay for alarm temperature
F2 High pressure switch

目录

目录	16
1 应用场合	17
2 技术参数	17
3 壁挂式安装	17
4 安全须知	17
5 操作和控制方式	17
5.1 控制器控制	17
5.1.1 控制器的操作	17
5.1.2 参数列表	18
5.1.3 参数设置	18
5.1.4 设定目标温度	19
5.1.5 设定温度范围	19
5.1.6 屏幕显示	19
5.1.7 按键显示	19
5.1.8 开机与关机	19
5.2 报警说明	20
5.3 报警信息及系统状态	20
5.4 强制制冷	20
6 过滤网	21
7 技术信息	21
7.1.1 空调的运行	21
7.1.2 冷凝水的排放	21
8 使用说明	21
8.1 空调的安装	22
8.1.1 空调的外部式安装	22
8.1.2 空调的半嵌入式安装	22
8.2.1 连接要点	23
8.2.2 过压保护和电源线载荷	23
9 检验和维修	23
9.1 概述	23
9.2 用压缩空气清吹	24
10 存放和处理	25
11 供货范围和保修	25
12 电路图	26

1 应用场合

1 应用场合

控制机柜空调是被设计并用于把控制柜的空气冷却同时把柜内热量排出柜外，从而保护温度敏感部件。

2 技术参数

参见标签

3 壁挂式安装

标准的壁挂式空调适用于外部式安装。在机柜上开孔然后安装空调。拧紧空调背面的螺纹孔，然后使用垫圈和螺母进行固定。

4 安全须知

为了正确使用本设备，请仔细阅读以下安全须知。

- 为了防止机柜及空调翻倒，必须用螺栓把机柜在地上固定好。
滚轮是用来保证控制柜门的正常开关的
一个带有内置空调的外壳应当只用于当空调是用一个单独的运输板固定时。
安装之前，请确保以下情况：
- 根据现场的位置选择空调的布置以保证良好的通风
- 现场没有过度潮湿和过多的灰尘。
- 进气口位于柜体的上部
- 电压与频率必须与空调铭牌上的数值相匹配
- 使用环境温度不超过 50 摄氏度
- 包装没有破损。破损包装上的油痕说明制冷剂已经泄漏。任何包装上的破损都可能是后续损坏的原因
- 控制柜应保持密封，并且避免柜门频繁打开，以免外部空气进入，产生过多冷凝水（超出空调消除能力的冷凝水，将自动通过排水口排出）。
- 与墙面以及其他系统之间至少保持 200mm 的距离
- 选择安装位置时，应避免控制柜内部的电子元器件阻挡空调的进出风，
- 该设备在安装时，应保证上下位置正确，左右、前后方向垂直，其最大倾斜度为 2 度。
- 提供冷凝水排放
- 空调的安装及电气接线必须由专业人员严格参照本说明书的相关规定来操作。
- 仅使用原装备件和配件
- 控制柜内部元器件的散热量不得超过空调的可用制冷能力。
- 用户不能用任何方式改动空调
- 禁止用水冲洗空调，防止造成人员伤害及机器的损坏。

5 操作和控制方式

空调安装完成后，应至少等待 30 分钟后（让内部冷冻油回流到位以保证正常的润滑和制冷）才可接通电源开始操作。

威图机柜空调装配说明书

5.1 控制器控制



图 1: 控制显示器

电路连接之后，内部的风扇启动，控制柜内的空气开始循环，这样有助于保证柜内的温度分布平均。冷凝风扇及压缩机启停由控制器控制。压缩机重新启动的最小间隔时间为 3 分钟。开关温度差为 5K。为了避免柜内制冷区域冷热换热短路及由其引起不充分制冷的危险，或者只有柜内的某些区域部分冷却，开关差设定应根据实际需要来设定。考虑经济因素（节能），柜内的温度 T_i 同样需要根据实际需要来设定。

5.1.1 控制器的操作

显示终端为一个 3 位 7 段的显示器，它可以显示柜内摄氏温度和故障码。实际的柜内温度在 H1 上实时显示。当产生一个系统信息时，显示器的显示在当前柜内温度和系统信息间交替切换。

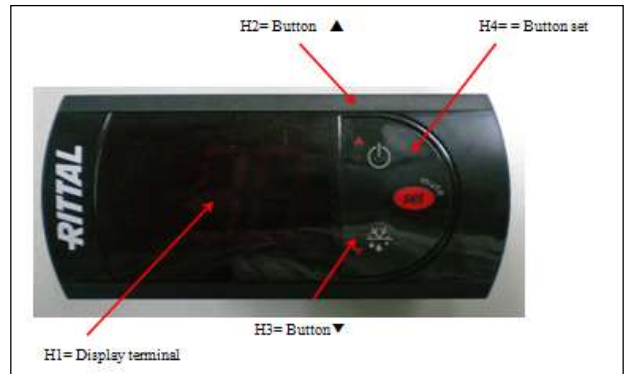
5 操作和控制方式

5.1.2 参数列表

参数类型	代码	参数	最小值	最大值	默认值	描述
F	PS	密码	0	99	22	修改设置参数的保护代码（默认为 22）。这个口令可以通过显示器修改。
S	St	设定点	r1	r2	35	St:用户设定点; r1: 最小允许设定点; r2: 最大允许设定点。参数 St 确定冷柜或冷库内期望保持的温度（设定点）。
F	rd	控制偏差	0	+19	5	增加到（反向模式下，减少到）温度设定点的值： r4=低值： 更高精确度的温度控制；在最小偏差值时，高频率的启动/停止压缩机（有损坏压缩机的风险） rd= 高值： 低精确度的温度控制；在最小偏差值时，低频率的启动/停止压缩机 重要说明：通过设置参数来限制压缩机每小时的激活次数和最小停机时间，可以有效保障压缩机的使用寿命（请考参数“压缩机保护”C 参数）。
C	r1	设定点最小值	20	r2	30	R1 和 R2: 设置设定点的温度范围。
C	r2	设定点最大值	r1	50	45	
C	cc	强制制冷持续时间	0	15	1 (hours)	
C	A0	报警及风扇差动	-20	+20	2	详见章 5.2
F	AH	用于高温报警的绝对和相对温度	-50	+99	10	详见章 5.2
C	Ad1	上电时高温报警延时	0	199	30	当刚上电时，高温报警有延时. 也就是说当设备刚上电就达到高温条件, 延时继电器启动(Ad1)参数. 仅当延时继电器时间达到(Ad1)参数设定时, 高温报警继电器才开始.

5.1.3 参数设置

可通过前面板小键盘修改的运行参数被分成三类：频繁使用的参数（F 类），结构参数（C 类）和其他参数（S 类）。使用一条口令设限对结构参数（默认为 22）的访问进行保护，以防止意外或未授权的修改。

访问 F 类参数:

- 按住 SET 键并保持 3 秒以上（在报警情况下，使蜂鸣器静音）来显示参数 ‘PS’（口令）代码；
- 使用 UP 键和 DOWN 键上下翻动显示参数的名称。当翻动到的参数与显示屏上的 LED 图标对应时，LED 灯会亮（参考参数表）；
- 按下 SET 键来显示与参数有关的值，分别使用 UP 或 DOWN 键来增加或减小参数的值；
- 按下 SET 键临时存储参数的新值，并再次显示参数；如果任何参数需要修改，请重复以上操作步骤；
- 按住 SET 键并保持 3 秒以上时间，将参数永久保持并退出参数设置程序。

访问 C 类参数:

- 按住 SET 键并保持 3 秒以上（在报警情况下，使蜂鸣器静音）来显示参数 ‘PS’（口令）代码；
- 按下 SET 键输出口令；使用 UP 或 DOWN 键来上下翻动显示数字，直到显示 “22”（访问参数的口令）
- 按下 SET 键确认口令；
- 使用 UP 键和 DOWN 键上下翻动显示参数的名称。当翻动到的参数与显示屏上的 LED 图标对应时，LED 灯会亮（参考下表）；
- 按下 SET 键来显示与参数有关的值；分别使用 UP 或 DOWN 键来增加或减小参数的值；
- 按下 SET 键临时存储参数新值，并再次显示参数；
- 如果任何参数需要修改，请重复以上操作步骤；按住 SET 键并保持 3 秒以上时间，将参数永久保持并退出参数设置程序

5 操作和控制方式

访问 S 类参数:

- 按住 SET 键 1 秒以上,参数会闪动;
- 分别使用 UP 或 DOWN 键来增加或减小参数值;
- 按下 SET 键临时存储参数的新值, 并再次显示参数.

5.1.4 设定目标温度

控制柜内部温度由工厂预设为 35℃。可通过下面操作改变参数。

可参看 S 类参数设置。

5.1.5 设定温度范围

- 按住 SET 键并保持 3 秒以上来显示参数 ‘PS’ (口令) 代码;
- 按下 SET 键输出口令; 使用 UP 或 DOWN 键来上下翻动显示数字, 直到显示 “22” (访问参数的口令)
- 按下 SET 键确认口令; 使用 UP 键和 DOWN 键上下翻动显示参数的名称。当翻动到的参数 r1 或 r2 时, 停止翻动
- 按下 SET 键来显示与参数有关的值; 分别使用 UP 或 DOWN 键来增加或减小参数的值
- 按下 SET 键临时存储参数的新值, 并再次显示参数;
- 如果任何参数需要修改, 请重复以上操作步骤; 按住 SET 键并保持 3 秒以上时间, 将参数永久保持并退出参数设置程序。



注意!
在没有威图公司授权情况下, 禁止客户更改“r1”及“r2”的参数值

5.1.6 屏幕显示





图2: 控制显示器

编号	功能	正常运行			启动
		开	关	闪烁	
1	压缩机	开	关	请求	开

2	数字	两个带有小数点的数字, 显示范围为-99 到 99
---	----	---------------------------

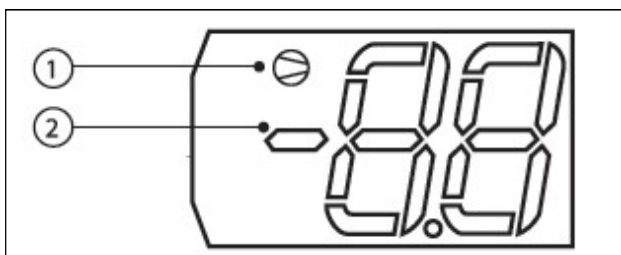

注意!
(*带三个数字值的参数可以通过显示器设定。这种情况下, 显示屏将显示为 “— “

5.1.7 按键显示



图3: 显示按钮

编号	正常运行	Start up/ reset	
	单独按按钮		
1	持续超过 3 秒: 压缩机启动/停止	-	
2	<ul style="list-style-type: none"> ▪ 1 秒: 显示/设定设定值; ▪ 持续超过 3 秒; 进入参数设定菜单 (输入密码 22) ▪ 将听得到的报警设为静音 (蜂鸣器) 	-	一起按住所有键激活参数复位程序

启动/恢复出厂设置

- 断开电源
- 重新连接电源时按住按钮 2 和 3
- 显示器将显示消息“CF”
- 几秒后会系统重启并恢复出厂设置

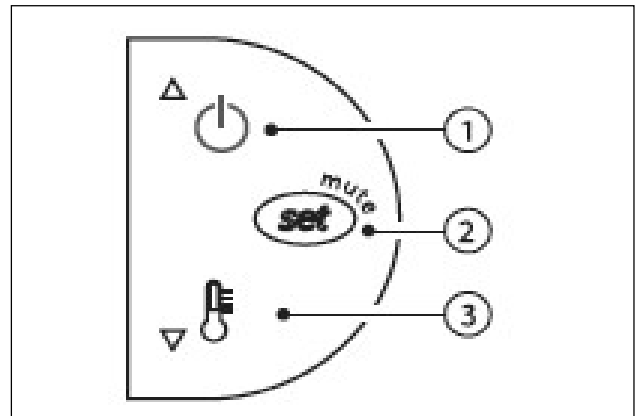
5.1.8 开机与关机

启动装置: 按下 UP 键超过 3 秒 (当按下这个键后, 显示屏显示 ON)

关闭装置: 按下 UP 键超过 3 秒 (当按下这个键后, 显示屏显示 OFF), 与设定的传感器测量的温度交替显示。

在 OFF 状态下, 下列功能无效压缩机/执勤设定/强制制冷

压缩机的控制

- 任务设置
- 连续循环

9 检查和维修

5.2 报警说明

A0: 报警和风机温差

- 表示用来激活高温报警报警的温差（“AH”）。出现一个报警时（如图中所示），“A0”的值决定了温度报警的实际触发温度。“A0”的值（负值或正值）决定了“AH”报警的属性（分别为绝对或相对），具体说明如下：
 - A0 ≤ 0 “AH” 表示绝对
 - A0 > 0 “AH” 表示相对设定点



图4:高温报警

高温报警 AH 说明

AH 设定：10 度是出厂设定（-50 和 99 是上限和下限）
 原厂设定，就是 ST 设定（35 度），AO 设定（2 度）
 AH 设定（10 度）

例如：如果机柜内部温度是 46 度（ST 设定）35+
 （AH 设定）10=45 度，这个时候空调显示温度是 46 度，大于 45 度，这时空调会报警 AH。（只要机柜内部温度大于 45 度就会报警 AH）

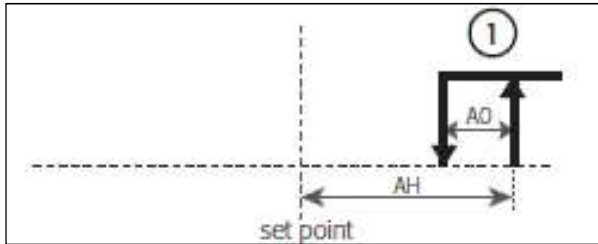
AH 报警的消除

例如：如果机柜内部温度是 42 度（ST 设定）35+
 （AH 设定）10-（AO 设定）2=43 度，这时空调显示温度是 42 度，小于 43 度，空调就会报警消除。只要机柜内部温度小于 43 度就会报警消除

高温报警输出

- 显示和蜂鸣输出：显示器上会显示：“AH”图标及有蜂鸣声。
- 干结点报警输出：通过空调的用户终端接口上的触点发送高温报警信息（详见空调电路图）。
 - 端子“1” C(公共点)
 - 端子“2” 常开。



注意!

当刚上电时，高温报警有延时。也就是说当设备刚上电就达到高温条件，延时继电器启动(Ad1)参数。仅当延时继电器时间达到(Ad1)参数设定时，高温报警继电器才开始。



注意!

延时继电器“Ad”单位是秒，而延时继电器“Ad1”单位是分钟。



注意!

干结点报警输出的继电器在未有报警输出时一直为常开状态，一旦有高温故障时，继电器闭合

高压报警 HP 输出

显示和蜂鸣输出：显示器上会显示：“HP”图标及有蜂鸣声。

- 干结点报警输出：通过空调的用户终端接口上的触点发送报警信息（详见空调电路图）。
 - 端子“1” C(公共点)
 - 端子“2” 常开。



注意!

干结点报警输出的继电器在未有报警输出时一直为常开状态，一旦有高压故障时，继电器闭合

门卫报警 HP 输出（选配）

- 显示和蜂鸣输出：显示器上会显示：“HP”图标及有蜂鸣声。
- 干结点报警输出：通过空调的用户终端接口上的触点发送报警信息（详见空调电路图）。
 - 端子“1” C(公共点)
 - 端子“2” 常开。



注意!

干结点报警输出的继电器在未有报警输出时一直为常开状态，一旦有高压故障时，继电器闭合

5.3 报警信息及系统状态

屏幕显示	蜂鸣音	报警继电器	系统信息	解决措施
E0	运行	停止	环境温度传感器损坏	检查传感器的接线，必要时更换
HI	运行	运行	高温报警	检查制冷量及制冷机
HP	运行	运行	高压报警	关机并拆洗冷凝器侧的过滤网
HP	运行	运行	开门报警（选配）	检查机柜门是否正确关闭复位

5.4 强制制冷

强制制冷用于保持制冷持续动作，不管装置内的温度是多少。强制制冷的作用是用来迅速降低温度，甚至使温度降到设定点以下，例如：在装满冷柜后。在这

9 检查和维修

个阶段，温度可能降低至低于为参数 AH 设定的设定点以下。

要通过按键启动或禁止强制制冷，首先要按住 **set** 键持续超过 3 秒；进入参数设定菜单（输入密码 22），然后更改 **CC**（出厂设定 0）参数为 1，然后同时按下 **UP** 和 **DOWN** 键超过 3 秒，显示屏将显示“cc”并且图标将闪烁（闪烁 2 次，停止）；

6 过滤网

作为附件的不锈钢滤层为粗滤器，可以滤掉空气中的大粉尘或绒毛。由于鼓风机吸入的空气压足够高，通过滤层和空调外部回路的微尘将被吹送到柜内。这并不影响空调的工作。



注意！

请参照机器铭牌下方的维护标签定期对过滤网进行维护！若不对过滤网进行维护，当现场环境恶劣造成过滤网严重堵塞时，会造成制冷系统异常，甚至损坏制冷设备。



图 5: 更换过滤垫

7 技术信息

空调（压缩空调）由四个主要部件组成：制冷剂压缩机、蒸发器、冷凝器和毛细管，它们通过相关的管道系统相连。这个管道回路中充满着易沸腾物质，即制冷剂。R134a (CH 2FCF3) 制冷剂不含氯气，它对臭氧的破坏 (ODP) 为零，因此该制冷剂是环保的。在密封的冷却循环中集成了一个过滤干燥器，它为空调提供了有效的保护，使其有效抵御湿气、酸蚀、杂质和外来物质。

7.1.1 空调的运行

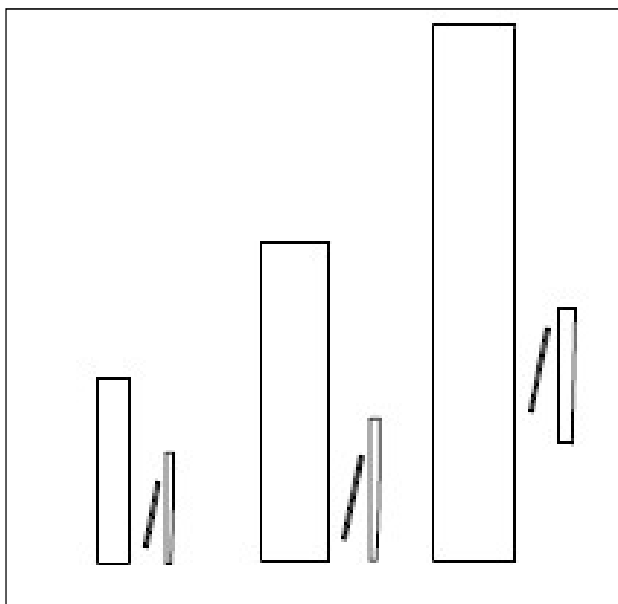

图 6: 制冷机的运行原理

压缩机将气态的制冷剂从蒸发器带走并将其压缩到一个较高的压力，进入冷凝器。在这个过程中，制冷剂的温度上升，超过周围的环境温度，热量可以通过冷凝器的表面向周围环境散发。然后制冷剂被液化，通过恒温控制的毛细管制冷剂回到蒸发器，在蒸发器中制冷剂低压蒸发。完成蒸发的热量来自控制柜的内部，从而使其冷却。这样就完成了制冷循环，上述的热交换过程又重新开始。

7.1.2 冷凝水的排放

冷凝水管安装在蒸发器隔板上，从而保证可能在蒸发器中形成的任何冷凝水（高湿度、柜内温度过低）从制冷机的底部排出。为了实现这个目标，需要在冷凝管连接处安装一个软管。冷凝水必须能够自由流掉。如果冷凝水排放的距离过远，必须采取措施，避免软管弯曲，并进行检查，改正排出方式。

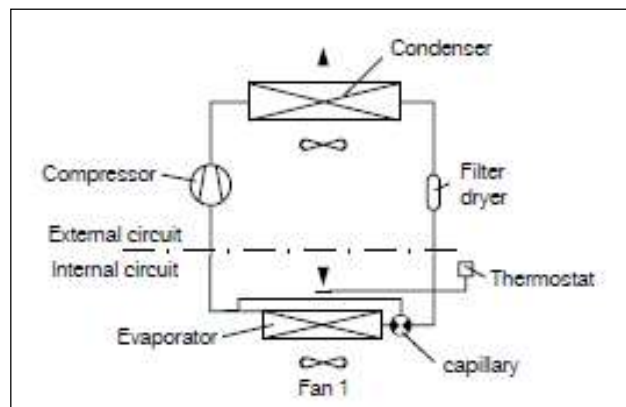

图 7: 更换过滤垫

8 使用说明

存储、维护、运输和配置

做为免维护、密封的系统，在工厂已经添入了制冷循环所需的制冷剂，并进行了泄露测试和功能测试。安装的免维护风扇采用滚珠轴承，对其进行了防潮和防尘保护，并且装配了温度监控器，其预期寿命至少为 30,000 工作小时。因此，冷却机很大程度上是无需维护的。外部空气循环部件需要用压缩空气经常进

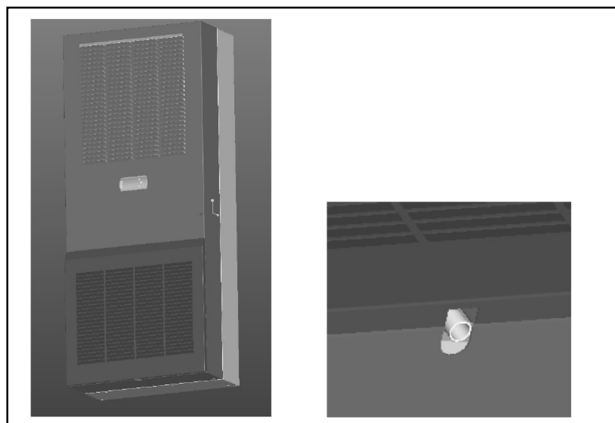
9 检查和维修

行清洗。推荐只有大颗粒棉绒的时候使用滤层，从而避免冷凝器的堵塞（过滤垫置换，图 7.1）。注意：任何维护工作前，必须切断冷却机的电源。

存储温度：空调严禁置于温度超过+70℃的场所。

运输位置：空调必须总是竖直运输。

废物处理：封闭的制冷循环包括制冷剂和油，为了保护环境，必须正确处理这些废物。可以在 Rittal 进行废物处理。

我们保留进行技术改进的权利。

8.1 空调的安装

机柜空调可以选择装在机柜外部（1），部分装在机柜内部（2）。



图 8: 安装方式

此时，按照说明书提供的开孔尺寸图在机柜侧板或门上切安装口，并钻出相应的孔。

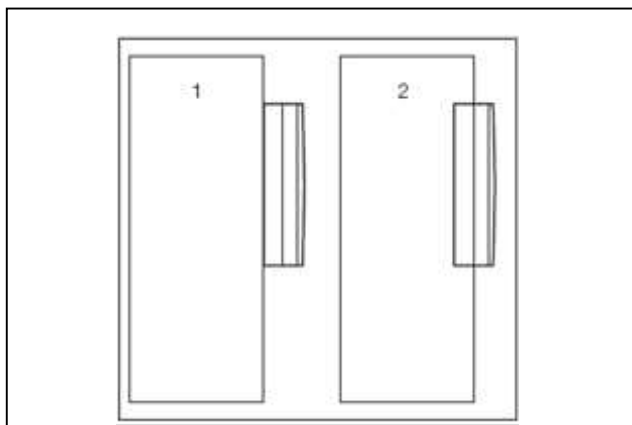

注意!

在 TS 侧板或后板内安装 SK 3370724 型装置时，建议使用机柜面板固定件 TS 8800.071（见威图产品宣传册）。

8.1.1 空调的外部式安装

- 将所供的密封条切成正确的长度，沿装置的背面仔细地粘贴，使接合处不留任何缝隙。



图 9: 粘贴密封条

- 将所供的埋头螺钉拧入装置背面的盖螺母中
- 用所提供的垫圈和螺母固定本装置。

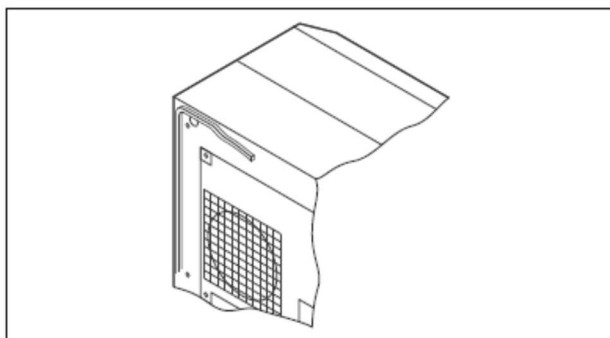

图 10: 固定方式(除了 3370220 外所有的 compact 空调)

8.1.2 空调的半嵌入式安装

- 将 4 个法兰用螺钉固定在空调上。

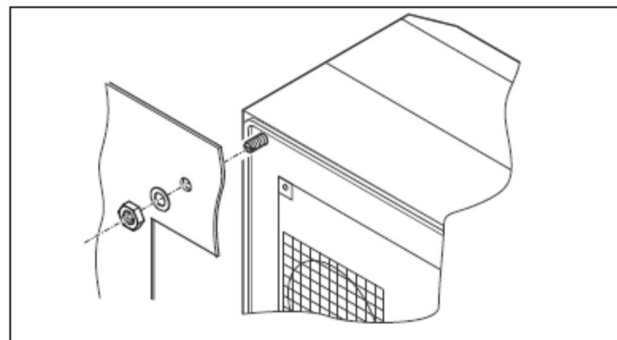

图 11: 固定安装法兰

- 将密封条切成正确的长度，沿后安装条仔细地粘贴，使连接点不留任何缝隙。

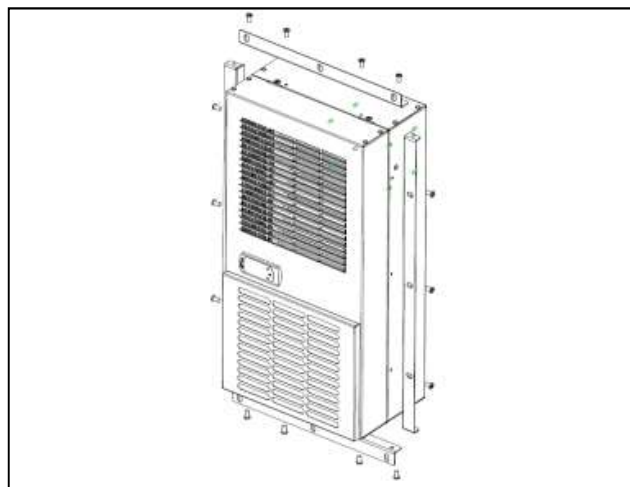

图 12: 帖密封条

- 从机柜内部将本装置推进安装切口，用垫圈和螺母从外面将其固定到机柜上。

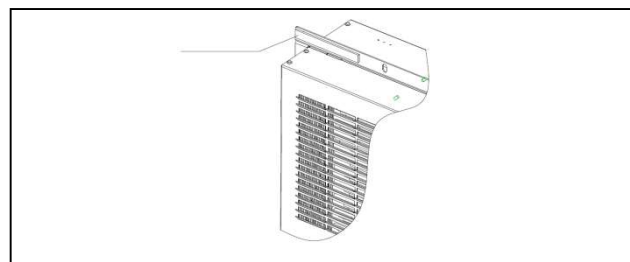

图 13: 空调固定

8.2 电源连接

当执行电气安装时，应遵守国家和地方的所有现行条例以及当地供电局的规定。电气安

9 检查和维修

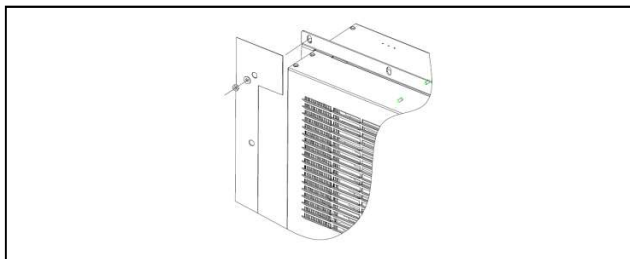
装应由合格的电工进行，电工必须遵守现行的标准和条例。依据产品铭牌上的型号标示，按下列图示连接



图 14: 空调固定

型号	输入电源
SK 3370220	L1-N
SK 3370320	L1-N
SK 3370370	L1-N
SK 3370420	L1-N
SK 3370424	L1-L2
SK 1194420	L1-N
SK 1194424	L1-L2
SK 3370520	L1-N
SK 3370524	L1-L2
SK 1194550	L1-N
SK 1194554	L1-L2
SK 3370620	L1-N
SK 1194620	L1-N
SK 3370724	L1-L2
SK 1194724	L1-L2

8.2.1 连接要点

- 线路电压和频率须与铭牌标示一致。
- 机柜空调必须通过一个可隔离所有插脚的隔离装置连接到电源上，在切断时应确保至少3mm的接触空隙。
- 在电源端本装置的上游不得连接任何别的温度控制
- 应根据铭牌标示，安装保险丝（“K”特性微型断路器或电机断路器或变压器断路器），以便在电缆和设备短路时进行保护
- 电源连接必须确保无噪声电势均衡

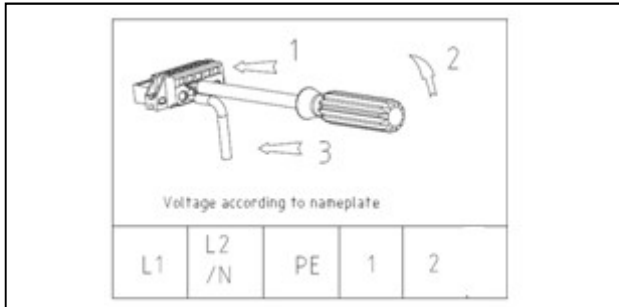
8.2.2 过压保护和电源线载荷

- 本装置自身没有过压保护。操作人员必须在电源端进行测量，以确保有效的照明和过压保护。电源电压不得超过±10%的允许偏差。
- 根据IEC 61 000-3-11，本装置只能用在每相100A以上的连续载流量（进线电源）电源电压为400/230V的场合。如有需要，需咨询供电局，以确保与电网连接点处的连续载流量足够连接这样的装置。

- 单相和两相装置中的风扇和压缩机为固有安全装置（热绕组保护）。这也适用于SK 3370420、SK 1194424、SK 3370520、SK 1194524、SK 3370724、SK 1194724型装置的带变压器的空调装置。
- 应根据铭牌标示，安装保险丝（“K”特性微型断路器、电机断路器或变压器断路器），以便在电缆和设备短路时进行保护。根据铭牌标示，选择电机断路器/变压器断路器：将其设置在规定的最小值。这将达到电缆和设备的最佳短路保护。例如：规定的设置范围MS/TS 6.3 – 10 A，设置为6.3 A。

9 检验和维修



触电危险！

本装置带电。

打开前必须切断电源，并采取适当的措施防止其被意外接通。

9.1 概述

冷却管路设计为免维护全封闭式系统。机柜空调出厂时按要求的量充装了制冷剂，进行了泄漏检查，并经过了功能测试运行。配备的免维护风扇都安装在球轴承上，进行了防潮防尘保护。其寿命至少为 30,000 个工作小时。因此，机柜空调基本上是免维护的。所需要的维护只是在发现外部空气管路部件变脏时用真空吸尘器或压缩空气对其进行清洁。可用去油剂等非易燃清洁剂清除油渍。维护间隔：2,000 个工作小时，视周围空气中的污染程度可缩短维护间隔。



小心！

火灾危险！

不得用易燃液体进行清洗。

维护步骤：

- 检查脏污程度
- 过滤器脏吗？必要时更换过滤器。
- 冷凝翅片脏吗？必要时清洁。
- 检查压缩机和风扇产生噪声的情况。

9 检查和维修

9.2 用压缩空气清吹



图 15: 断开电源线



图 16: 拆卸空调盖顶部螺钉



图 17: 拆卸空调盖底部螺钉



图 18: 打开空调盖



图 19: 从显示器上断开接头



图 20: 拆卸外部冷凝风扇螺钉 (1)



图 21: 拆卸外部冷凝风扇螺钉 (2)

9 检查和维修



图 23: 断开风扇接头



图 24: 用压缩空气清吹冷凝器盘管



图 25: 用压缩空气清吹压缩机及管路

图 22: 拆卸外部冷凝风扇

10 存放和处理



小心！损坏危险！

机柜空调在存放中不得置于 $+70^{\circ}\text{C}$ 以上的温度下。

在存放过程中，机柜空调必须保持直立。封闭的冷却管路中充装有制冷剂和油，必须将它们正确地处理，以免影响环境。可在威图工厂中进行处理。请联系本公司，征求意见。

11 供货范围和保修

- 1 个冷却机，待连接
- 1 个密封带
- 1 套安装和使用说明书

保修：

在正确使用的条件下（参见 4. 安全注意事项），在质保期间，退回的冷却机将在工厂免费修理和更换。冷却机仅用于控制柜的冷却，如果被错误连接电源或者不正确操作（参考使用说明书），我们无责任，不承担任何损失。

12 电路图

12 电路图

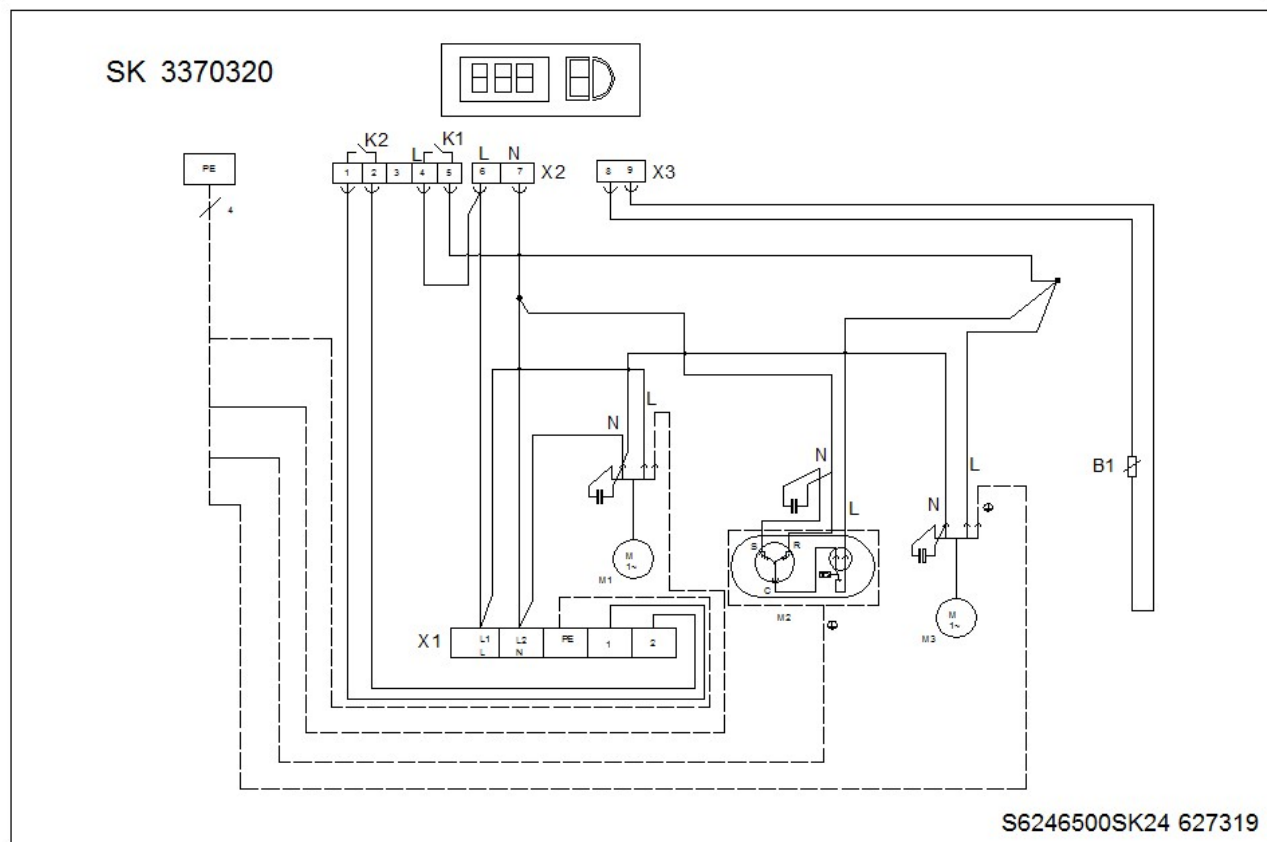
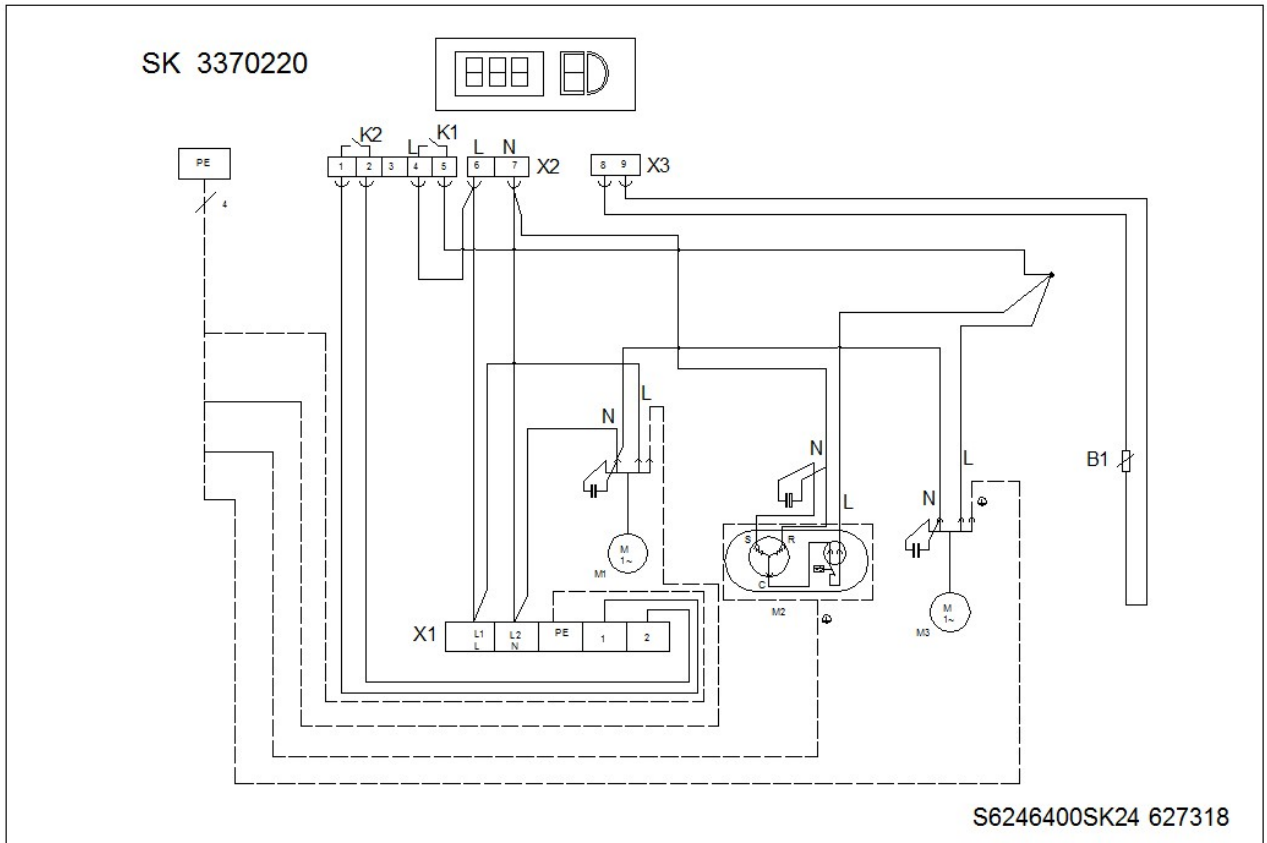

12 电路图

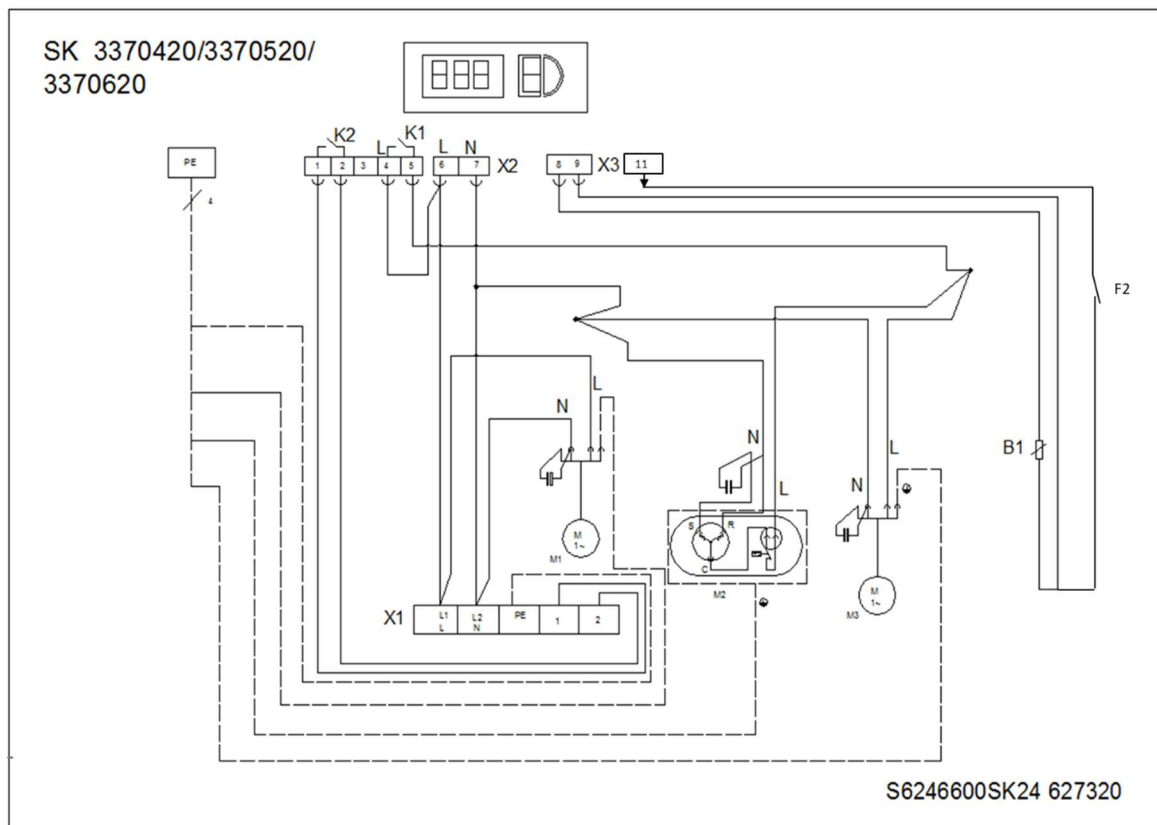

SK 3370724:

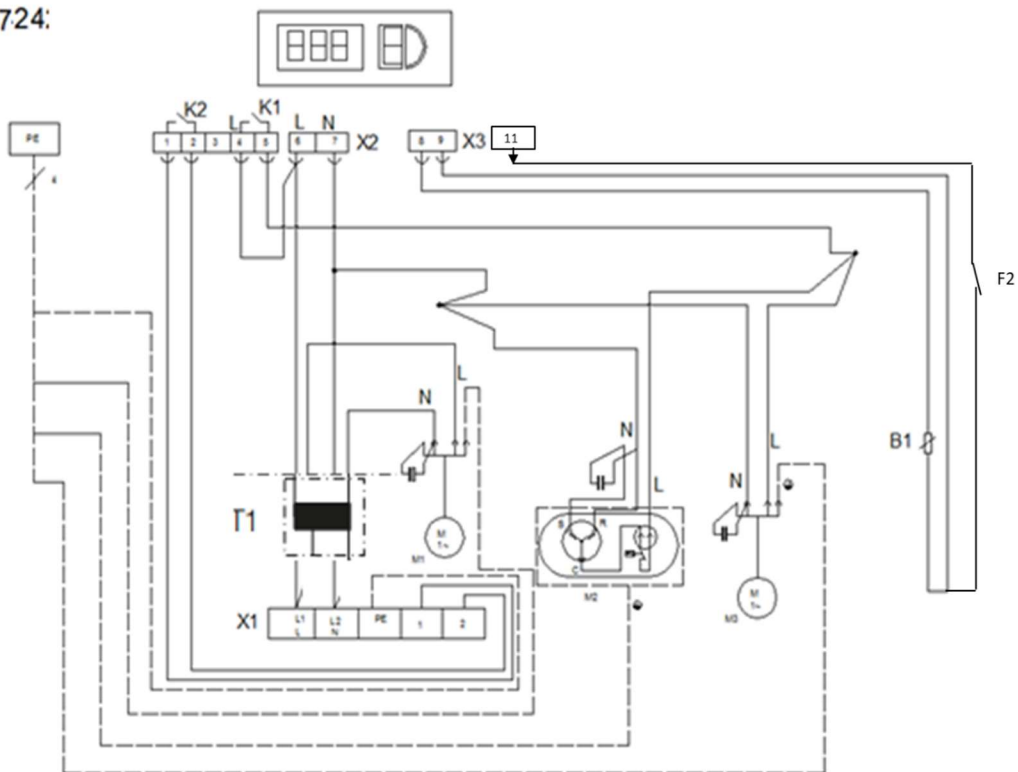

X2	电源连接端子	M3	冷凝风扇
X3	温度传感器连接端子	B1	室内温度传感器
X1	外部接线端子	K1	压缩机和蒸发风扇继电器
M1	蒸发风扇	K2	温度报警继电器
M2	压缩机	F2	高压开关

Rittal – The System.

Faster – better – everywhere.

- Enclosures
- Power Distribution
- Climate Control
- IT Infrastructure
- Software & Services

Rittal Electro-Mechanical Technology (Shanghai)Co.,Ltd
Address No.1658, Minyi Road, Songjiang Industrial District Shanghai
Phone +86 21 51157799-0
User support email address: service@rittal.cn
Web site: <http://www.rittal.cn>

2st. edition / 09-2019 / Ident. Nr.: 627905

ENCLOSURES

POWER DISTRIBUTION

CLIMATE CONTROL

IT INFRASTRUCTURE

SOFTWARE & SERVICES

FRIEDHELM LOH GROUP

