

# Rittal – The System.

Faster – better – everywhere.

**RiLineX –  
CB-Geräteadapter**

**RiLineX –  
Circuit-breaker component adaptor**

**RiLineX –  
Adaptateurs de disjoncteurs**

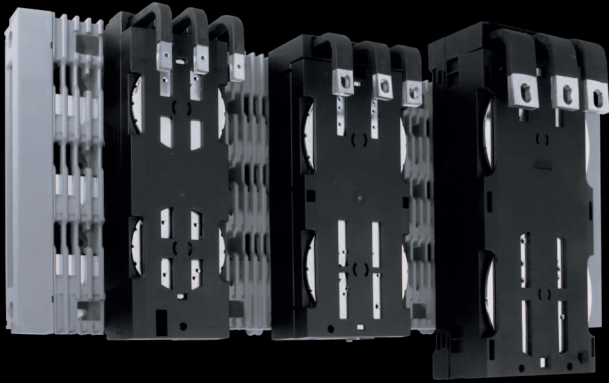

9360.500

9360.503

9360.512

9360.513

9360.525

9360.535

9360.600

9360.603

9360.612

9360.613

9360.625

9360.635

**Montageanleitung**

**Assembly instructions**

**Notice de montage**

ENCLOSURES

POWER DISTRIBUTION

CLIMATE CONTROL

IT INFRASTRUCTURE

SOFTWARE & SERVICES

FRIEDHELM LOH GROUP



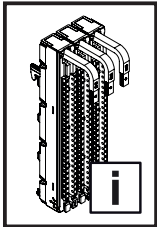

**Inhaltsverzeichnis**  
**Contents**  
**Sommaire**

DE

<b>1. Hinweise zur Dokumentation</b>	<b>4</b>
1.1 CE-Kennzeichnung	4
1.2 Aufbewahrung der Unterlagen	4
1.3 Verwendete Symbole	4
1.4 Mitgelieferte Unterlagen	4
1.5 Entsorgung von Elektroaltgeräten!	4
<b>2. Sicherheitshinweise</b>	<b>5</b>
<b>3. Montage und Aufstellung</b>	<b>16</b>
<b>9360.500/.503/.600/.603</b>	
3.1 Demontage Easy-fix 9360.500/.503	16
3.2 Einstellung Sammelschienenstärke	17
3.3 Montage CB-Geräteadapter	19
3.4 Einstellung und Montage Easy-fix 9360.500/.503	19
3.5 Montage und Demontage Universal-fix 9360.600/.603	20
3.6 Montage Anschlussraumabdeckung	22
3.7 Demontage CB-Geräteadapter	22
<b>4. Montage und Aufstellung</b>	<b>23</b>
<b>9360.512/.513/.612/.613</b>	
4.1 Demontage Easy-fix 9360.512/.513	23
4.2 Einstellung Sammelschienenstärke	24
4.3 Montage CB-Geräteadapter	25
4.4 Einstellung und Montage Easy-fix 9360.512/.513	26
4.5 Montage und Demontage Universal-fix 9360.612/.613	27
4.6 Demontage CB-Geräteadapter	28
<b>5. Montage und Aufstellung</b>	<b>29</b>
<b>9360.525/.535/.625/.635</b>	
5.1 Demontage Easy-fix 9360.525/.535	29
5.2 Drehung Kabelabgang	30
5.3 Montage CB-Geräteadapter	31
5.4 Einstellung und Montage Easy-fix	32
5.5 Montage und Demontage Universal-fix 9360.625/.635	33
5.6 Demontage CB-Geräteadapter	34
<b>6. Hinweise zur Gerätemontage auf Easy-fix/Universal-fix</b>	<b>36</b>
6.1 Easy-fix	36
6.2 Universal-fix	37
6.3 Schaltertabelle	38
<b>7. Anwendung mit RiLine60</b>	<b>40</b>
<b>8. Technische Daten</b>	<b>41</b>
<b>9. Lagerung</b>	<b>44</b>
<b>10. Garantie</b>	<b>44</b>
<b>11. Kundendienstadressen</b>	<b>44</b>

EN

<b>1. Notes on documentation</b>	<b>4</b>
1.1 CE labelling	4
1.2 Storing the documents	4
1.3 Symbols used	4
1.4 Other applicable documents	4
1.5 Disposal of waste electrical equipment!	4
<b>2. Safety instructions</b>	<b>5</b>
<b>3. Assembly and siting</b>	<b>16</b>
<b>9360.500/.503/.600/.603</b>	
3.1 Dismantling the Easy-fix 9360.500/.503	16
3.2 Setting the busbar thickness	17
3.3 Mounting the circuit-breaker component adaptor	19
3.4 Setting and mounting the Easy-fix 9360.500/.503	19
3.5 Mounting and dismantling the Universal-fix 9360.600/.603	20
3.6 Mounting the connection space cover	22
3.7 Dismantling the circuit-breaker component adaptor	22
<b>4. Assembly and siting</b>	<b>23</b>
<b>9360.512/.513/.612/.613</b>	
4.1 Dismantling the Easy-fix 9360.512/.513	23
4.2 Setting the busbar thickness	24
4.3 Mounting the circuit-breaker component adaptor	25
4.4 Setting and mounting the Easy-fix 9360.512/.513	26
4.5 Mounting and dismantling the Universal-fix 9360.612/.613	27
4.6 Dismantling the circuit-breaker component adaptor	28
<b>5. Assembly and siting</b>	<b>29</b>
<b>9360.525/.535/.625/.635</b>	
5.1 Dismantling the Easy-fix 9360.525/.535	29
5.2 Rotation of cable outlet	30
5.3 Mounting the circuit-breaker component adaptor	31
5.4 Setting and mounting the Easy-fix	32
5.5 Mounting and dismantling the Universal-fix 9360.625/.635	33
5.6 Dismantling the circuit-breaker component adaptor	34
<b>6. Notes on device installation on Easy-fix/Universal-fix</b>	<b>36</b>
6.1 Easy-fix	36
6.2 Universal-fix	37
6.3 Table of switches	38
<b>7. Application with RiLine60</b>	<b>40</b>
<b>8. Technical specifications</b>	<b>41</b>
<b>9. Storage</b>	<b>44</b>
<b>10. Warranty</b>	<b>44</b>
<b>11. Customer services addresses</b>	<b>44</b>

FR

<b>1. Remarques relatives à la documentation</b>	<b>4</b>
1.1 Certification CE	4
1.2 Conservation des documents	4
1.3 Symboles utilisés	4
1.4 Autres documents applicables	4
1.5 Mise au rebut/recyclage des appareils électriques !	4
<b>2. Consignes de sécurité</b>	<b>5</b>
<b>3. Montage et implantation références 9360.500/.503/.600/.603</b>	<b>16</b>
3.1 Démontage du système Easy-fix références 9360.500/.503	16
3.2 Réglage de l'épaisseur des barres de courant	17
3.3 Montage de l'adaptateur de disjoncteur	19
3.4 Réglage et montage du système Easy-fix référence 9360.500/.503	19
3.5 Montage et démontage du système Universal-fix référence 9360.600/.603	20
3.6 Montage du capot recouvrant la zone de raccordement	22
3.7 Démontage de l'adaptateur de disjoncteur	22
<b>4. Montage et implantation références 9360.512/.513/.612/.613</b>	<b>23</b>
4.1 Démontage du système Easy-fix référence 9360.512/.513	23
4.2 Réglage de l'épaisseur des barres de courant	24
4.3 Montage de l'adaptateur de disjoncteur	25
4.4 Réglage et montage du système Easy-fix référence 9360.512/.513	26
4.5 Montage et démontage du système Universal-fix référence 9360.612/.613	27
4.6 Démontage de l'adaptateur de disjoncteur	28
<b>5. Montage et implantation références 9360.525/.535/.625/.635</b>	<b>29</b>
5.1 Démontage du système Easy-fix références 9360.525/.535	29
5.2 Inversion du sens de sortie des câbles	30
5.3 Montage de l'adaptateur de disjoncteur	31
5.4 Réglage et montage du système Easy-fix	32
5.5 Montage et démontage du système Universal-fix référence 9360.625/.635	33
5.6 Démontage de l'adaptateur de disjoncteur	34
<b>6. Remarques sur l'installation des appareils sur les systèmes Easy-fix/Universal-fix</b>	<b>36</b>
6.1 Système Easy-fix	36
6.2 Système Universal-fix	37
6.3 Tableau des disjoncteurs	38
<b>7. Utilisation avec RiLine60</b>	<b>40</b>
<b>8. Caractéristiques techniques</b>	<b>41</b>
<b>9. Stockage</b>	<b>44</b>
<b>10. Garantie</b>	<b>44</b>
<b>11. Coordonnées des services après-vente</b>	<b>44</b>

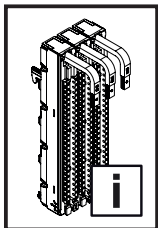

Inhaltsverzeichnis  
Contents  
Sommaire

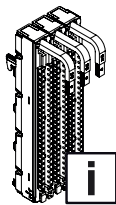

3 – 15, 36 – 39, 41 – 44

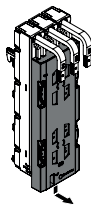

16

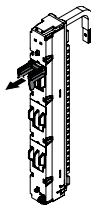

17 – 18

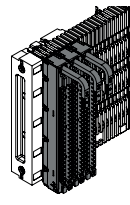

19

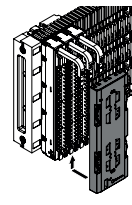

19 – 20

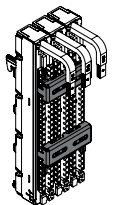

20 – 21

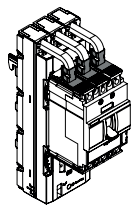

22

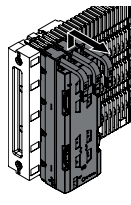

22

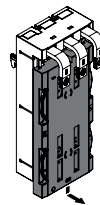

23

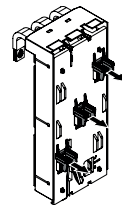

24

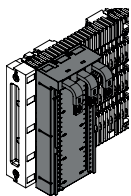

25

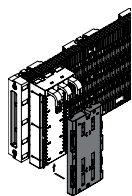

26

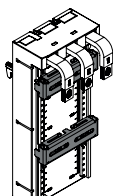

27

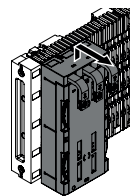

28

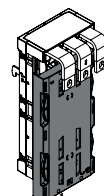

29

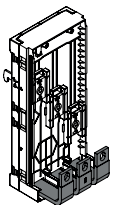

30 – 31

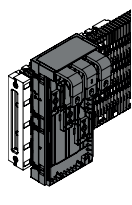

31

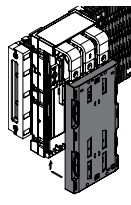

32

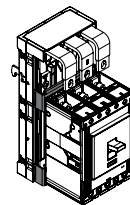

33

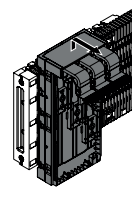

34 – 35

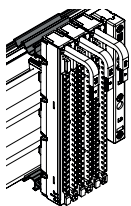

40

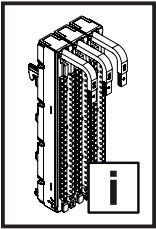

- 1. Hinweise zur Dokumentation
- 1. Notes on documentation
- 1. Remarques relatives à la documentation

DE

Die **Montageanleitung** richtet sich an alle Personen, die über eine entsprechende Fachausbildung verfügen, um Schaltschränke normgerecht mit elektrischen, elektronischen, mechanischen oder pneumatischen Betriebsmitteln auszurüsten, am Bestimmungsort aufzustellen bzw. zu montieren und betriebsfertig anzuschließen.

Lesen Sie sich die Anleitung aufmerksam durch und machen Sie sich mit dem Produkt vertraut, bevor Sie mit der Installation beginnen.

**1.1 CE-Kennzeichnung**

Die aktuelle Konformitätserklärung zu den für das Rittal Produkt geltenden EU Richtlinien steht auf der Homepage des Produktes unter dem Reiter „Approbationen“ zum Download zur Verfügung.

In der Konformitätserklärung werden auch die angewendeten Produktnormen aufgeführt.

**1.2 Aufbewahrung der Unterlagen**

Diese Montageanleitung ist Bestandteil des ausgelieferten Produktes. Sie muss für den Installateur, Instandhalter, Nutzer und das Reinigungspersonal jederzeit gut erreichbar in der Nähe des Produktes aufbewahrt werden.

**1.3 Verwendete Symbole**

Beachten Sie folgende Sicherheits- und sonstige Hinweise in der Anleitung:

**Symbol für eine Handlungsanweisung:**

- Der Blickfangpunkt zeigt an, dass Sie eine Handlung durchführen sollen.

**Sicherheits- und andere Hinweise:**



**Hinweis:**  
Nützliche Information und Besonderheiten.



**Hinweis:**  
Front-/Rückansicht.

**1.4 Mitgeltende Unterlagen**

Für die hier beschriebenen Produkte steht diese Montageanleitung als Download unter [www.rittal.de](http://www.rittal.de) zur Verfügung. Für Schäden, die durch Nichtbeachtung dieser Anleitung entstehen, übernehmen wir keine Haftung. Zusätzlich gelten auch die Anleitungen des verwendeten Zubehörs.

**1.5 Entsorgung von Elektroaltgeräten!**



**Elektroaltgeräte auf keinen Fall im Hausmüll entsorgen!**

EN

The **assembly instructions** are aimed at all persons who have an appropriate specialist training to allow them to equip enclosures to conform to standards with electrical, electronic, mechanical or pneumatic operating equipment, to place or install at the destination site and to connect ready to operate.

Please read the instructions through carefully and familiarise yourself with the product before commencing installation.

**1.1 CE labelling**

The current declaration of conformity to the EU directives applicable to the Rittal product is available for download on the product homepage under the "Approvals" tab for downloading.

The declaration of conformity also lists the product standards applied.

**1.2 Storing the documents**

These assembly instructions are part of the delivered product. They must be stored for the installation engineer, operator, maintenance and cleaning personnel in any easily accessible location near the product.

**1.3 Symbols used**

Observe the following safety and other notes in the instructions:

**Symbol identifying required actions:**

- The bullet point indicates an action to be performed.

**Safety and other notes:**



**Note:**  
Useful information and special features.



**Note:**  
Front/rear view.

**1.4 Other applicable documents**

These assembly instructions for the described products can be downloaded from [www.rittal.com](http://www.rittal.com). We cannot accept any liability for damage associated with failure to observe these instructions. The instructions for any accessories used also apply.

**1.5 Disposal of waste electrical equipment!**



**Never dispose of old electrical equipment in household waste!**

FR

La **notice de montage** s'adresse à toutes les personnes qui possèdent les compétences professionnelles correspondantes, pour équiper les armoires électriques avec du matériel électrique, électronique, mécanique ou pneumatique dans le respect des normes, pour les mettre en place ou les monter sur le lieu d'exploitation.

Lire attentivement la notice et se familiariser avec le produit avant de commencer l'installation.

**1.1 Certification CE**

La déclaration de conformité actuelle, concernant les directives européennes applicables au produit Rittal, est disponible pour téléchargement sur internet au niveau de la page d'accueil du produit sous l'onglet « Homologations ».

La déclaration de conformité mentionne également les normes appliquées au produit.

**1.2 Conservation des documents**

La présente notice de montage fait partie intégrante du produit fourni. Elle doit être conservée à proximité du produit et être facilement accessible à tout moment au personnel d'installation, de maintenance, d'exploitation et de nettoyage.

**1.3 Symboles utilisés**

Tenir compte des consignes de sécurité et autres directives contenues dans cette notice :

**Symbole indiquant une action à effectuer :**

- Le pictogramme en caractère gras indique que vous devez exécuter une action.

**Consignes de sécurité et autres directives :**



**Remarque :**  
Informations utiles et particularités.



**Remarque :**  
F = vue frontale  
R = vue arrière

**1.4 Autres documents applicables**

La présente notice de montage peut être téléchargée sur le site internet [www.rittal.fr](http://www.rittal.fr). Nous déclinons toute responsabilité en cas de dommages imputables à la non-observation des instructions contenues dans ces documents. Veuillez également tenir compte des instructions relatives aux accessoires utilisés.

**1.5 Mise au rebut/recyclage des appareils électriques !**



**Ne pas jeter les appareils électriques avec les déchets ménagers classiques !**

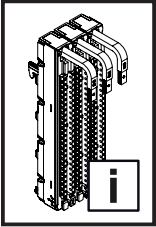

2. **Sicherheitshinweise**  
 2. **Safety instructions**  
 2. **Consignes de sécurité**

DE

 **Vor Installation- oder Servicearbeiten Stromversorgung unterbrechen, um Unfälle zu vermeiden.**

Die Geräte müssen in einem passenden Gehäuse eingebaut und gegen Verschmutzung geschützt werden. Inbetriebsetzung und Wartung nur durch Fachpersonal!

EN

 **To prevent electric shock, disconnect from power source before installing or servicing.**

Install in suitable enclosure. Keep free from contaminants. To be commissioned and maintained only by qualified personnel!

FR

 **Avant le montage et la mise en service, couper l'alimentation secteur afin d'éviter tout accident.**

Prévoir un coffret ou une armoire électrique approprié pour intégrer les appareillages afin de les protéger contre la saleté. La mise en service et l'entretien doivent être effectués uniquement par du personnel qualifié !

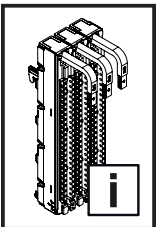

2. **Sicherheitshinweise**  
 2. **Safety instructions**

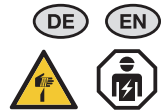

DE

**Bestimmungsgemäße Verwendung**

RiLineX ist ein Sammelschienensystem zum Einsatz in Niederspannungs-Schaltanlagen sowie Anwendungen der Steuer- und Regelungstechnik.

Bei Anwendung in explosions- oder erdbebengefährdeten Bereichen sowie bei anderen dynamischen Anwendungen sind die gültigen normativen oder gesetzlichen Vorschriften zu beachten.

Bei der Entwicklung in dieser Anleitung beschriebenen Produktes wurden bereits im Konstruktionsstadium sicherheitskritische Punkte über eine Risikobewertung nach EN ISO 12100 bewertet und vermieden. Da sich einige wenige Restrisiken nicht ausschließen lassen, sind folgende Hinweise zu beachten.

Bei einem Nichtbeachten der Sicherheitshinweise besteht die Möglichkeit der Gefahr für Gesundheit und Leben.

**Sicherheitshinweise:**

- Das in dieser Anleitung beschriebene Produkt muss während Transport, Auf- und Ausbau sowie Demontage gegen Umkippen, Herunterfallen und Verrutschen gesichert werden – ACHTUNG: Schwerpunktverschiebung!
- Beim Entpacken Verletzungsgefahr durch lose Bauteile.
- Aufbau und Inbetriebnahme nur durch ausgebildete Elektrofachkräfte.
- Quetsch- und Schnittgefahr beim Ein-/Ausbau der Komponenten.
- Vor der Montage des in dieser Anleitung beschriebenen Produktes ist sicherzustellen, dass das Gehäuse spannungsfrei geschaltet ist.
- Bei allen Montagearbeiten ist eine persönliche Schutzausrüstung zu tragen.
- Die Montage- und Bedienungsanleitung des zum Einbau von RiLineX gewählten Schranksystems ist zu beachten!

**Vor Inbetriebnahme:**

- Vorhandene Transportsicherungen entfernen.
- Sichtprüfung aller Befestigungsstellen.
- Kontrolle aller Anzugsdrehmomente.
- Werkzeug und Montagerestmaterialien entfernen.
- Elektrische Sicherheitsprüfung durchführen.
- Bauteile auf Mängelfreiheit überprüfen.

EN

**Intended use**

RiLineX is a busbar system for use in low-voltage switchgear as well as in control and instrumentation technology applications.

When used in areas where there is a risk of explosion or earthquake, as well as in other dynamic applications, the applicable normative or statutory regulations must be observed.

During the development of the product described in these instructions, as part of the design study, a risk evaluation according to EN ISO 12100 was conducted to evaluate and prevent safety-critical items. Because a few residual risks cannot be precluded, the following notes must be observed.

Danger to life and health in case of non-observance of the safety instructions.

**Safety instructions:**

- The product described in these instructions must be secured during transportation, assembly and dismantling in order to prevent potential tipping or sliding – CAUTION: Displacement of centre of gravity!
- Beware of injuries caused by loose components when unpacking.
- Assembly and commissioning only by trained qualified electricians.
- Risk of bruises and cuts when installing/removing components.

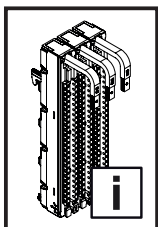

## 2. Safety instructions

## 2. Consignes de sécurité

## 2. Veiligheidsvoorschriften

## 2. Säkerhetsinstruktioner

- Before installing the product described in these instructions, ensure that the enclosure is de-energised.
- Personal protective equipment must be worn during all assembly work.
- Observe the assembly and operating instructions of the enclosure system selected for RiLineX!

### Prior to commissioning:

- Remove any existing transport locks.
- Visual inspection of all fixing points.
- Control of all tightening torques.
- Remove tools and unused assembly materials.
- Carry out an electrical safety check.
- Check that components are free of defects.

FR

### Utilisation correcte

RiLineX est un jeu de barres à utiliser dans les tableaux généraux basse tension ainsi que les installations de commande et de régulation. En cas d'utilisation dans des zones exposées à des risques d'explosion ou de tremblement de terre, ainsi que dans d'autres applications dynamiques, respecter les prescriptions normatives ou légales en vigueur.

Lors du développement du produit décrit dans cette notice, les points critiques en terme de sécurité ont déjà été analysés et prévenus lors de la fabrication via une analyse des risques conforme à la norme EN ISO 12100. Les remarques suivantes sont à respecter car quelques risques résiduels ne peuvent pas être supprimés.

Il est possible que la santé et la vie des personnes soient mises en danger en cas de non-respect des consignes de sécurité.

### Consignes de sécurité :

- Lors du transport, du montage et de l'équipement ainsi que du démontage, le produit décrit dans cette notice doit être sécurisé pour ne pas basculer, chuter ou glisser – ATTENTION : déplacement du centre de gravité !
- Risque de blessure possible lors du déballage à cause des composants livrés en vrac.
- Montage et mise en service uniquement par des électriciens formés et qualifiés.
- Risque de pincement ou de coupure lors du montage / démontage des composants.
- Il faut s'assurer que le coffret ou l'armoire électrique soit hors tension avant le montage du produit décrit dans cette notice.
- Un équipement de protection individuel doit être utilisé pour tous les travaux de montage.
- La notice de montage et d'utilisation des armoires électriques, dans lesquelles le système RiLineX sera intégré, doit être respectée !

### Avant toute mise en service :

- Retirer tous les dispositifs de sécurité de transport existants.
- Contrôler visuellement tous les points de fixation.
- Contrôler tous les couples de serrage.
- Retirer les outils et les matériaux de montage.
- Effectuer un test de sécurité électrique.
- Vérifier que les composants ne présentent aucun défaut.

NL

### Voorgescreven gebruik

RiLineX is een railsysteem voor gebruik in laagspanningsschakelapparatuur en toepassingen voor regel- en besturingstechniek.

Bij gebruik in explosie- of aardbevingengevaarlijke omgevingen en bij andere dynamische toepassingen moeten de geldende normatieve of wettelijke voorschriften in acht worden genomen.

Bij de ontwikkeling van de in deze handleiding beschreven producten zijn er al in de ontwerpfase veiligheidskritische punten vastgesteld en vermeden door middel van een risico-evaluatie conform EN ISO 12100. Omdat enkele resterende risico's niet kunnen worden uitgesloten, dienen de volgende instructies in acht te worden genomen.

Wanneer de veiligheidsinstructies niet in acht worden genomen, kan dit leiden tot een risico op letsel en overlijden.

### Veiligheidsvoorschriften:

- Het in deze handleiding beschreven product moet tijdens het transport en de opbouw tegen kantelen en wegglijden te worden beveiligd – LET OP: zwaartepuntverschuiving!
- Letselgevaar bij het uitpakken als gevolg van losse componenten.
- Montage en inbedrijfstelling alleen door opgeleide, gekwalificeerde elektriciens.
- Gevaar voor bekneling en snijwonden bij de in-/opbouw van componenten.
- Zorg vóór de montage van de in deze handleiding beschreven producten dat de kast spanningsvrij is geschakeld.
- Het is verplicht om tijdens alle montagewerkzaamheden de persoonlijke beschermende uitrusting te dragen.
- De montage- en gebruikshandleiding van het kastsysteem dat voor de installatie van RiLineX is gekozen, dient in acht te worden genomen!

### Vóór de inbedrijfstelling:

- Verwijder de aanwezige transportbeveiligingen.
- Voer bij alle bevestigingsplaatsen een visuele controle uit.
- Controleer alle aanhaalmomenten.
- Verwijder gereedschap en montage materiaal.
- Voer een elektrische veiligheidscontrole uit.
- RiLineX controleren op defecten en beschadigingen.

SE

### Ändamålsenlig användning

RiLineX är ett samlingssskenesystem för användning i lågspänningsställverk och applikationer inom styr- och reglerteknik.

Vid användning i explosions- eller jordbävningsfarliga områden samt vid andra dynamiska tillämpningar måste gällande normativa eller lagstadgade föreskrifter följas.

Vid utvecklingen av produkten som beskrivs i dessa instruktioner har säkerhetskritiska punkter utvärderats och undvikits redan på konstruktionsstadiet genom en riskbedömning enligt EN ISO 12100. Eftersom vissa kvarvarande risker inte kan undvikas helt ska följande information observeras.

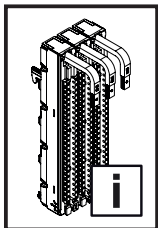

## 2. Säkerhetsinstruktioner

## 2. Istruzioni di sicurezza

## 2. Instrucciones de seguridad

Om säkerhetsanvisningarna inte följs kan det finnas risk för allvariga skador eller dödsfall.

### Säkerhetsinstruktioner:

- Produkten som beskrivs i dessa instruktioner måste säkras vid transport, montering och demontering så att den inte kan välta eller glida – OBS: Tyngdpunkten är förskjuten!
- Vid uppackning finns risk för skador på grund av lösa delar.
- Montering och idrifttagning får endast utföras av utbildade elektriker.
- Risk för kläm- och skärskador vid montage/demontage av komponenterna.
- Före montage av produkten som beskrivs i dessa instruktioner måste det säkerställas att skåpet är bortkopplat från spänning.
- Vid alla montagearbeten måste personlig skyddsutrustning bäras.
- Beakta monterings- och bruksanvisningen för det skåpsystem som valts för installationen av RiLineX!

### Före driftstart:

- Avlägsna transportsäkringarna om sådana finns.
- Gör en visuell kontroll av alla fästpunkter.
- Kontrollera alla åtdragningsmoment.
- Avlägsna verktyg och montagematerial.
- Gör en elektrisk säkerhetskontroll.
- Kontrollera att komponenterna är felfria.

IT

### Impiego conforme alle norme

RiLineX è un sistema di sbarre è utilizzato in applicazioni quali quadri elettrici in bassa tensione e quadri di automazione, controllo e regolazione.

In caso di utilizzo in aree a rischio di esplosione o terremoto, nonché in altre applicazioni dinamiche, è necessario rispettare le norme o le disposizioni di legge vigenti.

Durante lo sviluppo del prodotto descritto nelle istruzioni, già in fase di progettazione è stata eseguita una valutazione del rischio secondo la norma EN ISO 12100 volta a identificare gli aspetti critici legati alla sicurezza ed eliminare eventuali pericoli. Dal momento che non è possibile escludere altri rischi, è necessario attenersi alle seguenti istruzioni.

L'inosservanza delle avvertenze di sicurezza può comportare gravi lesioni personali, anche mortali.

### Istruzioni di sicurezza:

- Durante il trasporto, il montaggio, lo smontaggio e lo smaltimento, mettere in atto le precauzioni per evitare di cadere o scivolare  
ATTENZIONE: spostamento del baricentro!
- Durante il disimballaggio, rischio di lesioni a causa dei componenti non montati.
- Montaggio e messa in funzione solo da parte di personale qualificati.
- Rischio di schiacciamento e taglio durante il montaggio e lo smontaggio dei componenti.
- Prima di montare il prodotto descritto nelle istruzioni, assicurarsi che l'armadio non sia collegato all'alimentazione elettrica.
- I dispositivi di protezione individuale devono essere indossati durante tutte le operazioni di montaggio.
- Per l'installazione del RiLineX è necessario osservare anche le istruzioni di montaggio e installazione del quadro elettrico scelto!

### Prima della messa in funzione:

- Rimuovere i blocchi di sicurezza per il trasporto presenti.
- Controllare visivamente tutti i punti di fissaggio.
- Verificare tutte le coppie di serraggio con idoneo strumento.
- Rimuovere l'attrezzatura e i materiali di montaggio.
- Eseguire un collaudo elettrico di sicurezza.
- Verificare che i componenti non presentino difetti.

ES

### Uso correcto

RiLineX es un sistema de barras conductoras para su uso en apartamento de baja tensión y aplicaciones de tecnología de control y regulación.

En caso de uso en zonas con riesgo de explosión o terremoto, así como en otras aplicaciones dinámicas, se deben respetar las normas o disposiciones legales vigentes.

Durante el desarrollo del producto descrito en este manual como parte del estudio del diseño, ya se evaluaron y subsanaron los puntos críticos para la seguridad a través de una valoración de riesgo según EN ISO 12100. Puesto que algunos riesgos residuales no pueden evitarse, deben tenerse en cuenta las siguientes advertencias.

Ignorar las advertencias de seguridad puede comportar riesgos para la salud y la vida de las personas.

### Instrucciones de seguridad:

- El producto descrito en este manual debe asegurarse contra vuelcos, caídas y deslizamientos durante el transporte, el montaje y el desmontaje – ATENCIÓN: ¡Desplazamiento del centro de gravedad!
- Riesgo de lesiones al desembalar debido a piezas sueltas.
- Montaje y puesta en marcha sólo por electricistas cualificados.
- Riesgo de aplastamiento y corte al realizar el montaje y desmontaje de los componentes.
- Antes de montar el producto descrito en este manual debe comprobarse que el armario está libre de tensión.
- Debe usarse un equipo de protección personal para realizar cualquier trabajo de montaje.
- Deben observarse las instrucciones de instalación y funcionamiento del sistema de armarios seleccionado para la instalación de RiLineX.

### Antes de la puesta en marcha:

- Retirar los seguros de transporte.
- Inspección visual de todos los puntos de fijación.
- Control de todos los pares de apriete.
- Recoger las herramientas y los materiales de montaje.
- Realizar una prueba de seguridad eléctrica.
- Compruebe que los componentes no presenten defectos.

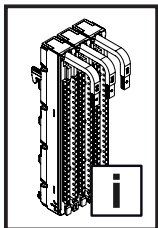

## 2. Turvallisuusohjeet

## 2. Sikkerhedsanvisninger

## 2. Wskazówki dotyczące bezpieczeństwa

### FI Määräystenmukainen käyttö

RiLineX on kiskojärjestelmä käytettäväksi pienjännitekeskuksissa sekä ohjau- ja automaatiosovelluksissa. Käytettäessä räjähdys- tai maanjäristysvaarallisissa tiloissa sekä muissa dynaamisissa sovelluksissa on noudatettava voimassa olevia ohjeita ja lakisääteisiä määräyksiä.

Ohjeissa kuvatus tuotteen kehityksessä on arvioitu ja ehkäisty turvallisuuden kannalta kriittisiä tekijöitä EN ISO 12100:n mukaisella riskinarvoilla.

Koska kaikkia riskejä ei voida välttää, on seuraavia ohjeita noudatettava. Mikäli turvallisuusohjeita ei noudateta, saattaa aiheutua vaara terveydelle ja hengelle.

#### Turvallisuusohjeet:

- Näissä ohjeissa kuvattu tuotteen kaatuminen ja liikkuminen on estettävä kuljetuksen, asennuksen ja purkamisen aikana – VAROITUS: Painopisteen siirtyminen!
- Pakkausta purettaessa irtonaiset rakenneosat aiheuttavat loukkaantumisaaran.
- Asennus ja käyttöönotto vain koulutettujen sähköasentajien toimesta.
- Puristumis-, viilto- ja leikkautumisvaara komponenttien asennuksen/purkamisen yhteydessä.
- Ennen näissä ohjeissa kuvattua tuotteen asentamista on varmistettava, että kotelon jännite on kytketty pois päältä.
- Henkilösuojaimia on käytettävä kaikkia asennustöitä tehtäessä.
- Noudata lisäksi RiLineX: än asennukseen valitun kaappi- tai kotelojärjestelmän asennus- ja käyttöohjeita!

#### Ennen käyttöönottoa:

- Poista mahdolliset kuljetustuet.
- Tarkista silmämääräisesti kaikki kiinnityskohdat.
- Tarkista kaikki vääntömomentit.
- Poista työkalut ja käyttämättömät asennusmateriaalit.
- Tarkasta sähköjärjestelmän turvallisuus.
- Tarkasta osien virheettömyys.

### DK Forskriftsmæssig anvendelse

RiLineX er et samleskinnesystem til brug i lavspændingskoblingsanlæg og applikationer inden for kontrol- og reguleringsteknologi. Ved anvendelse i eksplosions- eller jordskælvsramte områder samt ved andre dynamiske anvendelser skal de gældende normative eller lovmæssige forskrifter overholdes.

Ved udviklingen af produktet beskrevet i denne instruktion blev der i konstruktionsfasen foretaget en risikovurdering af sikkerhedskritiske punkter jf. EN ISO 12100, som herefter blev undgået. Det er ikke muligt at udelukke enkelte restriktioner, hvorfor følgende anvisninger skal overholdes.

Manglende overholdelse af sikkerhedsanvisningerne udgør en sundhedsrisiko og livsfare.

#### Sikkerhedsanvisninger:

- Produktet beskrevet i denne vejledning skal sikres mod væltning og udskridning under transport, opbygning og udbygning – OBS: Forskydning af tyngdepunktet!
- Ved udpakning er der risiko for personskade på grund af løse komponenter.
- Installation og idriftsættelse må kun foretages af uddannede elektrikere.
- Fare for knusning eller snitsår ved ind-/udbygning af komponenterne.
- Før produktet beskrevet i denne instruktion monteres, skal man sikre sig, at kabinettet ikke står under spænding.
- Ved alle former for monteringsarbejde skal der bæres personlige værnemidler.
- Installations- og betjeningsvejledningen for det skabssystem, der er valgt til installation af RiLineX, skal overholdes!

#### Før ibrugtagning:

- Transportsikringer skal fjernes.
- Visuel kontrol af alle fastgørelsessteder.
- Kontrol af alle tilspændingsmomenter.
- Fjern værktøj og monteringsmaterialer.
- Gennemfør en visuel kontrol af elsystemet.
- Kontroller, at komponenterne er fri for fejl.

### PL Używaj zgodnie z przeznaczeniem

RiLineX to system szyn zbiorczych do stosowania w rozdzielnicach niskiego napięcia oraz w aplikacjach technologii sterowania i regulacji. W przypadku stosowania w obszarach zagrożonych wybuchem lub trzęsieniem ziemi oraz w innych zastosowaniach dynamicznych należy przestrzegać obowiązujących przepisów normatywnych lub ustawowych.

Podczas projektowania produktu opisanego w tej instrukcji przeprowadzono ocenę ryzyka zgodnie z normą EN ISO 12100 w celu identyfikacji i zapobiegania elementom krytycznym dla bezpieczeństwa. Ponieważ nie można wykluczyć niektórych pozostałych zagrożeń, należy przestrzegać poniższych wskazań.

Nieprzestrzeganie wskazań bezpieczeństwa może spowodować zagrożenie dla życia i zdrowia.

#### Wskazówki dotyczące bezpieczeństwa:

- Podczas transportu, montażu i konfiguracji produktu opisanego w tej instrukcji, obudowa musi być zabezpieczona przed przewróceniem – UWAGA: przesunięcie środka ciężkości!
- Podczas rozpakowywania zachodzi niebezpieczeństwo zranienia przez luźne części.
- Instalacja i uruchomienie tylko przez przeszkolonych elektryków.
- Niebezpieczeństwo zgniecenia i skaleczenia przy montażu lub demontażu komponentów.
- Przed montażem produktu opisanego w tej instrukcji, należy się upewnić czy obudowa jest odłączona od napięcia.
- Podczas wszelkich prac montażowych należy stosować osobiste wyposażenie ochronne.
- Należy przestrzegać instrukcji montażu i obsługi systemu szaf sterowniczych wybranego do instalacji RiLineX!

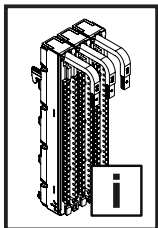

## 2. Wskazówki dotyczące bezpieczeństwa 2. Υποδείξεις ασφαλείας

### 2. Bezpečnostní pokyny

### 2. Инструкции за безопасност

#### Przed uruchomieniem:

- Usunąć istniejące zabezpieczenia transportowe.
- Sprawdzić wizualnie wszystkie punkty mocowania.
- Skontrolować wszystkie momenty dokręcania.
- Usunąć narzędzia i materiały montażowe.
- Przeprowadzić elektryczną kontrolę bezpieczeństwa.
- Sprawdzić, czy elementy konstrukcyjne nie mają wad.

#### CZ Použití v souladu s určením

RiLineX je přípojnicový systém určený pro průmyslové nízkonapěťové řídicí a distribuční rozváděče.

Při použití v oblastech s nebezpečím výbuchu nebo zemětřesení, stejně jako při jiných dynamicky náročných aplikacích, je nutné dodržovat platné normativní nebo zákonné předpisy.

Při konstrukčním vývoji produktu popsaného v těchto instrukcích byly hodnoceny a eliminovány bezpečnostní hrozby na základě hodnocení rizik podle EN ISO 12100. Protože i přes to není možné některá minimální rizika vyloučit, je nutno respektovat následující pokyny.

Důsledkem nerespektování bezpečnostních pokynů může být ohrožení zdraví a života.

#### Bezpečnostní pokyny:

- Výrobek popsaný v tomto návodu musí být během přepravy, montáže a demontáže zajištěn proti převrácení a sklouznutí – POZOR: Možnost posunutí těžiště!
- Při vybalování hrozí nebezpečí poranění o volné součástky.
- Instalaci a uvedení do provozu mohou provádět pouze osoby znalé, odborně způsobilé vykonávat práce na elektrickém zařízení
- Nebezpečí skřípnutí a pořezání při montáži/demontáži komponentů.
- Před montáží produktu popsaného v těchto instrukcích se ujistěte, že rozváděč není pod napětím.
- Během všech montážních prací je nutné používat osobní ochranné pracovní prostředky.
- Při instalaci RiLineX dodržujte návod k montáži a obsluze zvoleného rozváděčového systému!

#### Před uvedením do provozu:

- Odstraňte stávající transportní zajištění.
- Vizually zkontrolujte všechny montážní body.
- Překontrolujte všechny utahovací momenty.
- Odstraňte nářadí a montážní materiály.
- Proveďte kontrolu elektrické bezpečnosti.
- Zkontrolujte, bezvadný stav všech součástí.

#### BG За правилна употреба

RiLineX е шинна система за използване в разпределителни устройства за ниско напрежение и в приложения за технологии за управление и регулиране.

При употреба в зони с опасност от експлозия или земетресение, както и при други динамични приложения, трябва да се спазват валидните нормативни или законови разпоредби.

При проектирането и разработването на продуктът описан в инструкцията, са оценени и избегнати критичните точки по отношение на безопасността чрез оценка на риска съгласно EN ISO 12100. Тъй като някои остатъчни рискове не може да се изключат, трябва да се спазват следните указания.

При неспазване на инструкциите за безопасност съществува потенциална опасност за здравето и живота.

#### Инструкции за безопасност:

- Продуктът описан в инструкцията трябва да се обезопаси срещу преобръщане и преместване по време на транспорта, монтажа и демонтажа – ВНИМАНИЕ: изместване на центъра на тежестта!
- Опасност от нараняване от насипни компоненти при разопаковане.
- Монтаж и въвеждане в експлоатация само от обучени електротехници.
- Опасност от премазване и порязване при монтаж и демонтаж на компонентите.
- Преди монтажа на продуктът описан в инструкцията, трябва да се гарантира, че шкафът е разкачен от електрозахранването.
- При всички дейности, свързани с монтажа, трябва да се носят лични предпазни средства.
- Спазвайте инструкциите за монтаж и експлоатация на шкафовете избрани за инсталиране на RiLineX системата!

#### Преди пускане в експлоатация:

- Отстранете наличните транспортни осигуровки.
- Проверете визуално всички точки на закрепване.
- Проверете всички моменти на затягане.
- Отстранете инструментите и монтажните материали.
- Извършете проверка за електрическа безопасност.
- Проверете компонентите за липса на дефекти.

#### GR Προβλεπόμενη χρήση

Το RiLineX είναι ένα σύστημα busbar για χρήση σε διατάξεις χαμηλής τάσης και εφαρμογές τεχνολογίας ελέγχου και ρύθμισης.

Όταν χρησιμοποιείται σε περιοχές όπου υπάρχει κίνδυνος έκρηξης ή σεισμού, καθώς και σε άλλες δυναμικές εφαρμογές, πρέπει να τηρούνται οι ισχύοντες κανονιστικοί ή θεσμικοί κανονισμοί.

Κατά τη διάρκεια της ανάπτυξης του προϊόντος που περιγράφεται σε αυτές τις οδηγίες ως μέρος της μελέτης σχεδιασμού, πραγματοποιήθηκε αξιολόγηση κινδύνου σύμφωνα με το EN ISO 12100 για την αξιολόγηση και την αποτροπή κρίσιμων για την ασφάλεια αντικειμένων. Επειδή ορισμένοι ελάχιστοι κίνδυνοι δεν μπορούν να αποκλειστούν τελείως, θα πρέπει να τηρηθούν οι παρακάτω υποδείξεις.

Εάν αγνοηθούν οι υποδείξεις ασφαλείας υπάρχει κίνδυνος για τη ζωή και την υγεία.

#### Υποδείξεις ασφαλείας:

- Το προϊόν που περιγράφεται σε αυτές τις οδηγίες πρέπει να είναι ασφαλισμένο έναντι ανατροπής και ολίσθησης κατά τη μεταφορά,

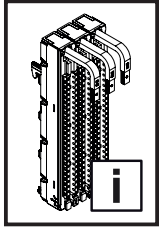

## 2. Υποδείξεις ασφαλείας

## 2. Instrucțiuni de siguranță

## 2. Sigurnosne upute

## 2. Biztonsági utasítások

- τοποθέτηση και αφαίρεσή του – ΠΡΟΣΟΧΗ: Μετατόπιση κέντρου βάρους!
- Κίνδυνος τραυματισμών από λυμένα εξαρτήματα, κατά την αποσυσκευασία.
- Εγκατάσταση και θέση σε λειτουργία μόνο από εκπαιδευμένους ηλεκτρολόγους.
- Κίνδυνος σύνθλιψης ή κοψίματος κατά την τοποθέτηση/αφαίρεση των εξαρτημάτων.
- Πριν εγκαταστήσετε το προϊόν που περιγράφεται σε αυτές τις οδηγίες, βεβαιωθείτε ότι το περιβλήμα είναι απενεργοποιημένο.
- Σε όλες τις εργασίες εγκατάστασης θα πρέπει να χρησιμοποιούνται μέσα ατομικής προστασίας.
- Πρέπει να τηρούνται οι οδηγίες εγκατάστασης και λειτουργίας του συστήματος περιβλήματος που έχει επιλεγεί για την εγκατάσταση του RiLineX!

### Πριν από την έναρξη λειτουργίας:

- Αφαιρέστε τις υπάρχουσες ασφάλειες μεταφοράς.
- Ελέγξτε οπτικά όλα τα σημεία στερέωσης.
- Ελέγξτε όλες τις ροπές σύσφιξης.
- Απομακρύνετε τα εργαλεία και τα υλικά συναρμολόγησης.
- Πραγματοποιήστε έναν έλεγχο ηλεκτρικής ασφάλειας.
- Ελέγξτε ότι τα εξαρτήματα δεν έχουν ελαττώματα.

RO

### Domeniul de utilizare

RiLineX este un sistem de bare pentru utilizarea în aplicații de comutație de joasă tensiune și tehnologie de control și reglare. În cazul utilizării în zone cu risc de explozie sau cutremur, precum și în alte aplicații dinamice, trebuie respectate normele și reglementările legale în vigoare.

La dezvoltarea produsului descris în aceste instrucțiuni, ca parte a studiului de design, au fost evaluate și prevenite punctele critice din punct de vedere al siguranței, încă din faza de proiectare, prin intermediul unei evaluări a riscurilor, conform EN ISO 12100. Deoarece nu pot fi excluse unele riscuri reziduale, trebuie respectate următoarele instrucțiuni.

La nerespectarea instrucțiunilor de siguranță, există posibilitatea periclitații sănătății și a vieții.

### Instrucțiuni de siguranță:

- Produsul descris în aceste instrucțiuni trebuie asigurat împotriva răsturnării sau alunecării în timpul transportului, montării și demontării – ATENȚIE: Deplasarea centrului de greutate!
- În timp ce despachetați, există riscul de rănire cauzată de componentele libere.
- Instalare și punere în funcțiune numai de către electricieni calificați.
- Pericol de strivire și tăiere la montarea/demontarea componentelor.
- Anterior montării produsului descris în aceste instrucțiuni, asigurați-vă că ați scos cutia/echipamentele de sub tensiune.
- În cazul tuturor lucrărilor de montare, este necesar să purtați echipament de protecție.
- Trebuie respectate instrucțiunile de instalare și funcționare pentru dulapul sau cofretul selectat pentru instalarea RiLineX!

### Înainte de punerea în funcțiune:

- Indepărtați toate echipamentele de siguranță pentru transport.
- Verificați vizual toate punctele de fixare.
- Verificați toate cuplurile de strângere.
- Indepărtați echipamentele și materialele de montare.
- Realizați un test de siguranță electrică.
- Verificați componentele pentru a vă asigura că nu prezintă defecte.

HR

### Predviđena uporaba

RiLineX je sustav sabirnica za upotrebu u niskonaponskim razvodnim postrojenjima, kao i u aplikacijama u tehnologiji upravljanja i regulacije.

Kada se koristi u područjima izloženim opasnostima od eksplozije ili potresa, kao i u drugim dinamičkim primjenama, normativni ili pravni propisi moraju se poštovati i primjenjivati.

Pri razvoju proizvoda spomenutog u ovim uputama već su u fazi izvedbe procijenjene i izbjegnute sigurnosno osjetljive točke na temelju procjene rizika sukladno normi EN ISO 12100. Budući da nije moguće isključiti malobrojne preostale rizike, potrebno je pridržavati se sljedećih uputa.

U slučaju nepridržavanja sigurnosnih uputa moguća je opasnost po zdravlje i život.

### Sigurnosne upute:

- Proizvod spomenut u ovim uputama se tijekom transporta, montaže i demontaže mora osigurati od prevrtanja i pada – POZOR: Pomicanje težišta!
- Prilikom raspakiravanja postoji opasnost od ozljede neučvršćenim dijelovima.
- Instalacija i puštanje u pogon vrši se samo od strane obučених električara.
- Opasnost od prignječenja i posjekotina prilikom montaže/demontaže dijelova.
- Prije montaže proizvoda spomenutog u ovim uputama provjerite je li veza kućišta i napajanja prekinuta.
- Obvezno nosite osobnu zaštitu opremu prilikom svih montažnih zahvata.
- Morate se pridržavati uputa za montažu i upotrebu RiLineX sustava u ormarima.

### Prije puštanja u pogon:

- Uklonite svu opremu za učvršćivanje pri transportu.
- Vizualno provjerite sva mjesta pričvršćivanja.
- Provjerite sve momente pritezanja.
- Uklonite alate i materijale za montažu.
- Obavite sigurnosnu provjeru električnog sustava postrojenja.
- Provjerite ispravnost svih komponenti.

HU

### Rendeltetés szerű használat

A RiLineX gyűjtősínrendszer kifeszűltségű kapcsolóberendezések, valamint vezérlés- és szabályozástechnikai alkalmazásoknál

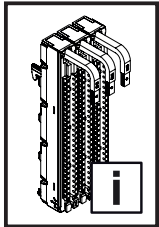

## 2. Biztonsági utasítások

### 2.2. Saugos nurodymai

### 2. Ohutusjuhised

használható.

Robbanásveszélyes vagy földrengésveszélyes területeken, valamint egyéb dinamikus alkalmazások esetén be kell tartani a hatályos szabványokat és jogszabályokat.

Az utasításban leírt termék konstrukciójának kidolgozásakor, a EN ISO 12100 szerinti kockázatértékelést végeztek és a biztonságtechnikailag kritikus pontok elkerülése érdekében intézkedéseket hoztak. Mivel néhány fennmaradó kockázat nem zárható ki, a következő tudnivalókat kérjük figyelembe venni.

A biztonsági utasítások figyelmen kívül hagyása esetén sérülés- és életveszély áll fenn.

#### **Biztonsági utasítások:**

- Az utasításban leírt terméket a szállítás, fel- és leszerelés során felbillenés vagy megcsúszás ellen biztosítani kell – FIGYELEM: súlypont-eltolódás!
- A kicsomagolás során a mozgó alkatrészek miatt sérülésveszély áll fenn.
- Telepítést és üzembe helyezést csak képzett villanyszerelő végezhet.
- Zúzódás és vágási sérülés veszélye a komponensek be-/kiszérése során.
- Az utasításban leírt termék felszerelése előtt ellenőrizni kell, hogy a szekrény áramtalanítva van-e.
- Minden szerelési munkához személyi védőfelszerelés viselése kötelező.
- A RiLineX beépítéséhez kiválasztott szekrényrendszer szerelési és üzemeltetési utasításait be kell tartani!

#### **Üzembe helyezés előtt:**

- A meglévő szállítási biztosítóelemeket távolítsa el.
- Az összes rögzítési pontot ellenőrizze szemrevételezéssel.
- Az összes meghúzási nyomatékot ellenőrizze.
- Távolítsa el a szerszámokat és szerelési anyagokat.
- Végezzen elektromos biztonsági ellenőrzést.
- Ellenőrizze, hogy az alkatrészek hibátlanok-e.



#### **Naudojimas pagal paskirtį**

„RiLineX“ - tai šynų sistema, skirta naudoti žemos įtampos skirstomuosiuose įrenginiuose ir valdymo bei reguliavimo technologijose. Naudojant sprogimo ar žemės drejbimo pavojaus zonos bei kitose dinamiškose aplinkose, reikia laikytis galiojančių normatyvinių ar teisinių reikalavimų.

Kuriant instrukcijose aprašytą produktą jau projektavimo etape buvo įvertinta rizika ir atliktas rizikos vertinimas pagal EN ISO 12100, atsižvelgta į saugos reikalavimus ir imtasi priemonių pašalinti galimus pavojus. Kadangi kai kurių liekamųjų pavojų pašalinti negalima, reikia laikytis toliau pateiktų nurodymų.

Nesilaikant saugos nurodymų kyla pavojus sveikatai ir gyvybei.

#### **Saugos nurodymai:**

- Pervežimo, montavimo ir išmontavimo metu instrukcijose aprašytą produktą reikia apsaugokite, kad neapvirstų ir nepasislinktų – DĖMESIO: svorio centro perkėlimas!
- Išpakuojant nepritvirtintus komponentus atsiranda tikimybė susižeisti.
- Montavimą ir paleidimą gali atlikti tik kvalifikuoti kvalifikuoti elektrikai.
- Montuojant / išmontuojant komponentus kyla pavojus prispausti ir įpjauti.
- Montuojant instrukcijose aprašytą produktą reikia užtikrinti, kad rėmu netekėtų įtampa.
- Atliekant bet kokius montavimo darbus būtina naudoti asmenines apsaugines priemones.
- Būtina laikytis „RiLineX“ montavimui pasirinktos aptvarų sistemos montavimo ir naudojimo instrukcijų!

#### **Prieš pradėdant naudoti:**

- Pašalinkite transportavimui naudotus fiksatorius.
- Apžiūrėkite visas tvirtinimo vietas.
- Patikrinkite visus užveržimo momentus.
- Nuimkite įrankius ir montavimo medžiagas.
- Patikrinkite, ar elektra įrenginyje naudojama saugiai.
- Patikrinkite, ar komponentai neturi defektų.



#### **Sihotstarbeline kasutus**

RiLineX on madalpinge lülitusseadmetes ning juhtimis- ja reguleerimistehnika rakendustes kasutatav ribasüsteem. Kasutamisel plahvatus- või maavärinaohtlikes piirkondades ning muudes dünaamilistes rakendustes tuleb järgida kehtivaid norme ja seadusi.

Käesolevas juhendis kirjeldatud toote arendamisel hinnati juba ehitusstaadiumis ohutuskriitliste punktide suhtes EN ISO 12100 kohase riskianalüüsi. Kuna mõningaid riske ei ole siiski võimalik välistada, tuleb järgida järgmisi juhiseid. Ohutusjuhiste järgimata jätmisel võib esineda oht tervisele ja elule.

#### **Ohutusjuhised:**

- Käesolevas juhendis kirjeldatud toodet tuleb transpordil, ülespanekul ja demonteerimisel ümberkukkumise ja libisemise vältimiseks kinnitada – TÄHELEPANU! Raskuskeskme nihkumine!
- Lahtipakkimisel vigastusohu lahtiste osade tõttu.
- Paigaldamine ja kasutuselevõtmine ainult koolitatud elektrikute poolt.
- Muljumis- ja löökoht komponentide paigaldamisel/eemaldamisel.
- Veenduge enne käesolevas juhendis kirjeldatud toote paigaldamist, et korpus on lülitatud pingevabaks.
- Kasutage kõikide paigaldustööde puhul isikukaitsevahendeid.
- RiLineX'i paigaldamiseks valitud korpusesüsteemi paigaldus- ja kasutusjuhendit tuleb järgida!

#### **Enne kasutuselevõttu:**

- Eemaldage transpordikaitsemed.
- Kontrollige visuaalselt kõiki kinnituskohti.
- Kontrollige kõiki pingutusmomente.
- Eemaldage tööriistad ja paigaldusmaterjalid.

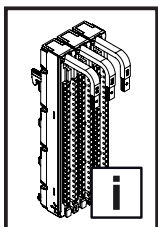

## 2. Ohutusjuhised

## 2. Drošības norādījumi

## 2. Varnostni napotki

## 2. Bezpečnostné pokyny

- Tehke elektrihoituse kontroll.
- Kontrollige, et osad oleksid veatud.

### LV Paredzētais lietošanas veids

RiLineX ir kopņu sistēma izmantošanai zemsprieguma komutācijas iekārtās, kā arī vadības un instrumentācijas tehnoloģiju lietotnēs. Lietojot sprādzienbīstamās vai zemestrīcu apdraudētās zonās, kā arī citos dinamiskos lietojumos, jāievēro spēkā esošie normatīvie vai likumīgie noteikumi.

Izstrādājot produktu, kas aprakstīts šajā instrukcijā, kā daļa no projektēšanas posma, tika veikts riska novērtējums saskaņā ar EN ISO 12100, lai novērstu drošībai kritiskus punktus. Tā kā nav iespējams izslēgt dažus atlikušos riskus, lūdzu, ņemiet vērā tālāk minētās prasības.

Neievērojot drošības prasības, var tikt apdraudēta veselība un dzīvība.

#### Drošības norādījumi:

- Transportēšanas, uzstādīšanas un demontāžas laikā, šajā instrukcijā aprakstītais produkts, jānodrošina pret apgāšanos un slidēšanu – UZMANĪBU: smaguma centra maiņa!
- Savainošanās risks ar nenostiprinātām detaļām izpakojojot.
- Uzstādīšanu un nodošanu ekspluatācijā var veikt tikai apmācīti elektriķi.
- Saspiešanas un sagriešanas risks, montējot un demontējot komponentus.
- Pirms, šajā instrukcijā aprakstītā produkta uzstādīšanas, pārliecinieties, ka korpuss ir atvienots no strāvas padeves.
- Salikšanas laikā vienmēr valkājiet individuālo aizsardzības līdzekli.
- Pie RiLineX uzstādīšanas, jāievēro izvēlētās korpusa sistēmas uzstādīšanas un ekspluatācijas instrukcija!

#### Ekspluatācijas uzsākšanai:

- Noņemiet esošos transportēšanas drošinātājus.
- Vizuāli pārbaudiet visas stiprinājumu vietas.
- Pārbaudiet visus pievilkšanas griezes momentus.
- Noņemiet liekos instrumentus un montāžas materiālus.
- Veiciet elektrodrošības pārbaudi.
- Pārbaudiet, vai detaļām nav defektu.

### SI Predvidena uporaba

RiLineX je sistem zbiralk za uporabo v nizkonapetostnih stikalnih napravah ter v aplikacijah nadzorne in instrumentacijske tehnologije. Pri uporabi na eksplozivnih ali potresno ogroženih območjih in pri drugih dinamičnih aplikacijah je treba upoštevati veljavne normativne ali zakonske predpise.

Pri razvijanju izdelka opisanega v teh navodilih so bili že v fazi izdelave ovrednoteni in odpravljeni varnostno kritični vidiki ocene tveganja v skladu s standardom EN ISO 12100. Nekaterih ostalih tveganj ni mogoče izključiti, zato je treba upoštevati naslednje napotke.

Če ne upoštevate varnostnih napotkov, se lahko pojavi nevarnost za zdravje in življenje.

#### Varnostni napotki:

- Izdelek, opisan v teh navodilih, mora biti med transportom, montažo in demontažo zavarovan pred prevrnitvijo in premikanjem – POZOR: premik težišča!
- Pri odpiranju embalaže obstaja nevarnost za nastanek poškodb zaradi nepritrjenih sestavnih delov.
- Namestitev in zagon lahko opravijo le usposobljeni električarji.
- Nevarnost zmečkanin in ureznin pri vgrajevanju/odstranjevanju komponent.
- Pred montažo izdelka opisanega v teh navodilih je treba preveriti, ali je ohišje brez napetosti.
- Pri vseh montažnih delih je treba nositi osebno varovalno opremo.
- Upoštevati je potrebno navodila za vgradnjo in uporabo sistema ohišij, izbranega za vgradnjo sistema RiLineX!

#### Pred zagonom:

- Odstranite razpoložljiva transportna varovala.
- Vizualno preverite vsa pritrdišča.
- Preverite vse zatezne momente.
- Odstranite orodje in pribor za montažo.
- Izvedite kontrolo varnosti električnih povezav.
- Preverite napake na sestavnih delih.

### SK Používanie v súlade s účelom

RiLineX je prípojnicový systém pre použitie v nízkonapäťových rozvádzačoch, ako aj v aplikáciách riadiacej a regulačnej techniky. Pri použití v priestoroch s nebezpečenstvom výbuchu alebo seizmickej aktivity, ako aj pri iných dynamických aplikáciách je potrebné dodržiavať platné normy alebo zákonné predpisy.

Pri vývoji tohto produktu, boli už v konštrukčnom štádiu vyhodnotené kritické body z hľadiska bezpečnosti na základe posúdenia rizika v zmysle normy EN ISO 12100, čím sa predišlo ich výskytu. Keďže nie je možné vylúčiť výskyt malého počtu zvyškových rizík, je nutné dodržiavať nasledovné pokyny.

V prípade nerespektovania bezpečnostných pokynov môže dôjsť k ohrozeniu zdravia a života.

#### Bezpečnostné pokyny:

- Výrobok popísaný v tomto návode musí byť počas prepravy, montáže a demontáže zaistený, aby sa zabránilo potenciálne prevrátenie alebo zosunutie – POZOR: Posunutie ťažiska!
- Nebezpečenstvo poranenia voľne uloženými konštrukčnými dielmi pri rozbaľovaní.
- Montáž a uvedenie do prevádzky, môže vykonávať iba vyškolený kvalifikovaný elektrikár.
- Nebezpečenstvo pomliaždenia a porezania pri montáži/demontáži komponentov.
- Pred montážou, zabezpečte beznapäťový stav rozvádzača.
- Pri akejkoľvek montáži používajte osobné ochranné pracovné pomôcky.
- Dodržujte pokyny uvedené v návode pre montáž a obsluhu rozvádzačového systému zvoleného pre RiLineX!

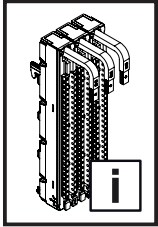

## 2. Bezpečnostné pokyny

## 2. Instruções de segurança

### Pred uvedením do prevádzky:

- Odstráňte príslušné prepravné poistky.
- Vykonať vizuálnu kontrolu všetkých miest slúžiacich na upevnenie.
- Vykonať kontrolu všetkých utahovacích momentov.
- Odstráňte náradie a montážny materiál.
- Vykonať bezpečnostnú skúšku elektrického zapojenia.
- Skontrolujte, či sú komponenty bez poškodenia.

PT

### Utilização

O RiLineX é um sistema de barramento para utilização em quadros de distribuição elétrica de baixa tensão e tecnologia de controle e regulação.

Em caso de utilização em áreas com risco de explosão ou sismo, bem como noutras aplicações dinâmicas, devem ser respeitadas as normas ou disposições legais em vigor.

Durante a fase de projeto do produto descrito nestas instruções, foi realizada uma avaliação dos riscos segundo a norma EN ISO 12100 para analisar e evitar aspetos críticos para a segurança. Como não é possível descartar alguns riscos residuais, é necessário seguir as instruções abaixo.

Existe um potencial risco de vida ou de danos para a saúde se as instruções de segurança não forem seguidas.

### Instruções de segurança:

- Fixar o produto descrito nestas instruções durante o transporte, a montagem e a configuração, para que não possa cair ou escorregar – ATENÇÃO: deslocamento do centro de gravidade!
- Tenha precaução com possíveis ferimentos causados por componentes soltos ao desembalar.
- Instalação e colocação em funcionamento apenas por electricistas qualificados.
- Há perigo de esmagamento e corte ao instalar/remover os componentes.
- Antes de instalar o produto descrito nestas instruções, certificar-se de que a alimentação de tensão da caixa está desligada.
- Ao realizar qualquer serviço de instalação, utilizar sempre o equipamento de proteção individual.
- Devem ser observadas as instruções de instalação e operação do sistema de armários selecionado para a instalação do RiLineX!

### Antes do primeiro funcionamento:

- Remover os dispositivos de segurança usados para o transporte.
- Fazer uma vistoria dos pontos de fixação.
- Checar todos os torques de aperto.
- Remover as ferramentas e material de montagem.
- Realizar um teste de segurança elétrica.
- Verifique se os componentes estão isentos de defeitos.

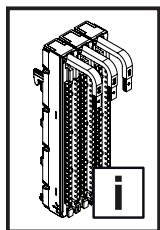

**Sicherheitshinweise**  
**Safety instructions**  
**Consignes de sécurité**

**Veiligheidsvoorschriften**  
**Säkerhetsinstruktioner**

	DE	EN	FR	NL	SE
	Warnung vor spitzem Gegenstand	Caution: Sharp object	Attention aux objets pointus	Waarschuwing voor scherpe voorwerpen	Varning för vassa föremål
	Installation durch Elektro-Fachkraft	Installation by specialist electricians	Installation par un électricien confirmé	Installatie door elektro-technisch personeel	Ska installeras av behörig elektriker

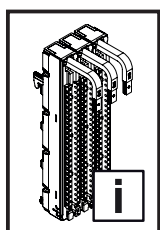

**Istruzioni di sicurezza**  
**Instrucciones de seguridad**  
**Turvallisuusohjeet**

**Sikkerhedsanvisninger**  
**Wskazówki dotyczące bezpieczeństwa**

	IT	ES	FI	DK	PL
	Pericolo oggetto affilato	Advertencia de objetos puntiagudos	Varo teräviä reunoja	Advarsel: Spidse genstande	Ostrzeżenie przed ostrym przedmiotem
	L'installazione deve essere eseguita da un elettricista qualificato	Instalación a realizar por un técnico electricista cualificado	Asennuksen saa suorittaa vain sähköalan ammattilainen	Skal installeres af uddannede elektriker	Instalacja przez elektryka

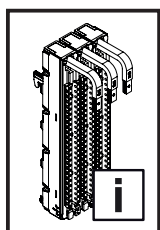

**Bezpečnostní pokyny**  
**Инструкции за безопасност**  
**Υποδείξεις ασφαλείας**

**Instrucțiuni de siguranță**  
**Šigurnosne upute**

	CZ	BG	GR	RO	HR
	Varování před ostrým předmětem	Предупреждение за опасност от остър предмет	Προειδοποίηση αιχμηρού αντικειμένου	Avertizare privind obiecte ascuțite	Opasnost od sječiva
	Instalace vyžaduje elektro odbornost	Монтажът се извършва от електро-техник	Εγκατάσταση από εκπαιδευμένο ηλεκτρολόγο	Instalarea se va face de un electrician calificat	Instalaciju smije provesti samo ovlašteno stručno osoblje za električarske radove

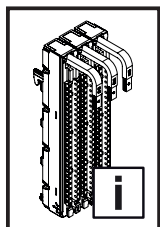

**Biztonsági utasítások**  
**Saugos nurodymai**  
**Ohutusjuhised**

**Drošības norādījumi**  
**Varnostni napotki**

	HU	LT	EE	LV	SI
	Figyelmeztetés hegyes tárgyak veszélyére	Įspėjimas apie aštrų daiktą	Hoiatus terava eseme eest	Brīdinājums par asiem priekšmetiem	Opozorilo pred ostrim predmetom
	A szerelést elektromos szakembernek kell elvégeznie	Turi įrengti elektrikas	Kvalifitseeritud elektriku poolne paigaldamine	Uzstādīšanu drīkst veikt tikai kvalificēts elektriķis	Namestitev lahko izvajajo samo usposobljeni strokovnjaki za elektrotehnicna dela

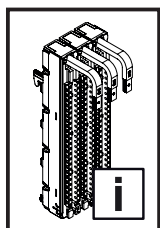

**Bezpečnostné pokyny**  
**Instruções de segurança**

	SK	PT
	Varovanie pred predmetom s ostrým hrotom	Cuidado com objetos pontiagudos
	Inštaláciu smie vykonávať len špecializovaný elektrotechnik	A instalação deve ser feita por um técnico electricista especializado

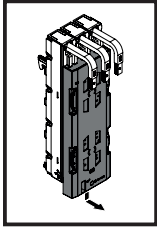

TX8

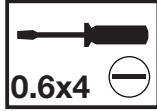

- 3. Montage und Aufstellung 9360.500/.503/.600/.603
- 3. Assembly and siting 9360.500/.503/.600/.603
- 3. Montage et implantation références 9360.500/.503/.600/.603

- 3.1 Demontage Easy-fix 9360.500/.503
- 3.1 Dismantling the Easy-fix 9360.500/.503
- 3.1 Démontage du système Easy-fix références 9360.500/.503

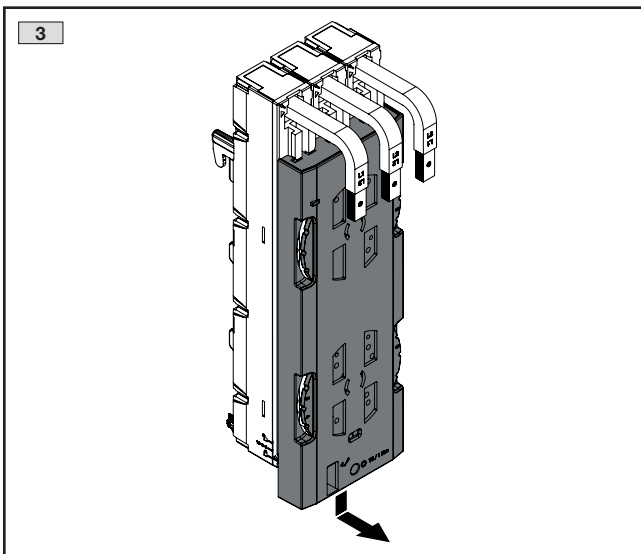
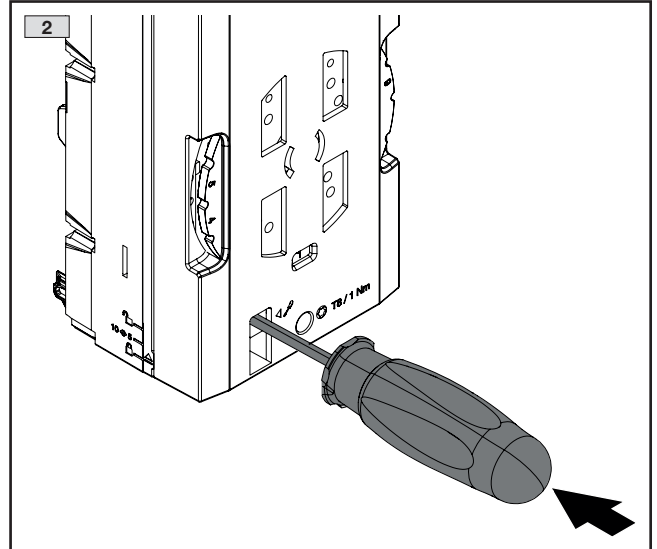
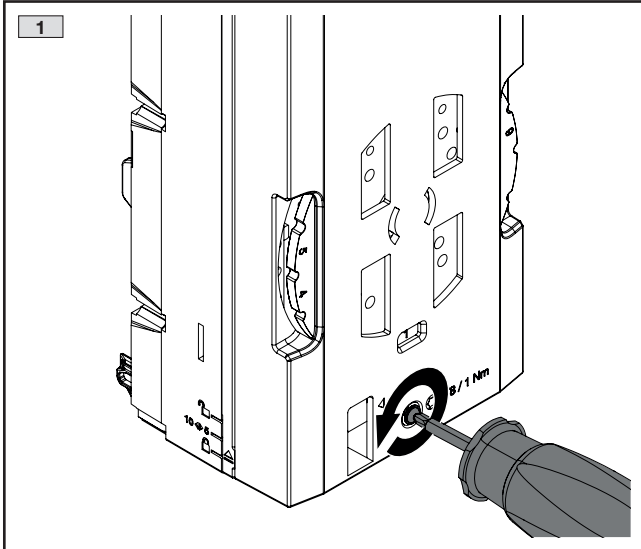

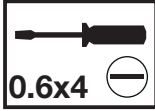
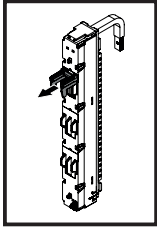

0.6x4

DE EN FR



3. Montage und Aufstellung 9360.500/.503/.600/.603
3. Assembly and siting 9360.500/.503/.600/.603
3. Montage et implantation références 9360.500/.503/.600/.603

3.2 Einstellung Sammelschienenstärke

3.2 Setting the busbar thickness

3.2 Réglage de l'épaisseur des barres de courant

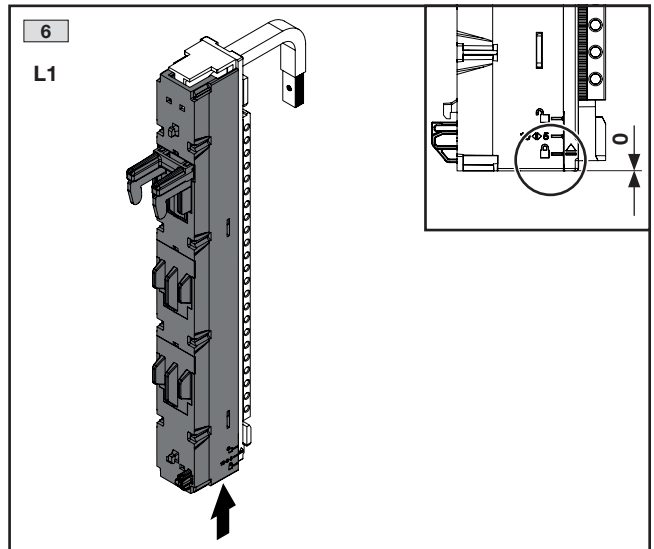
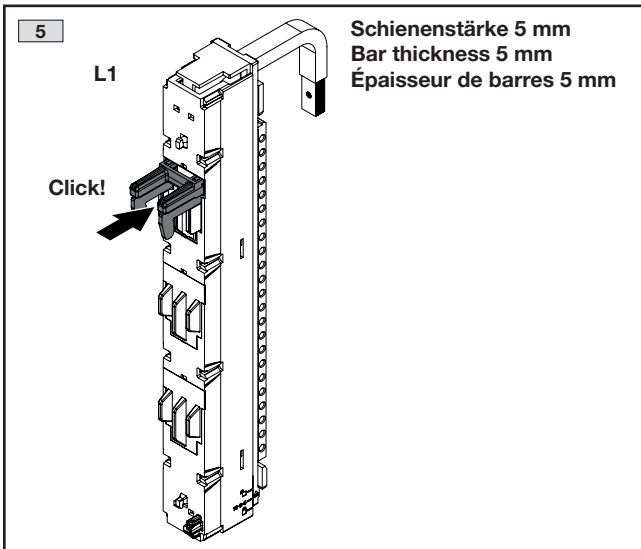
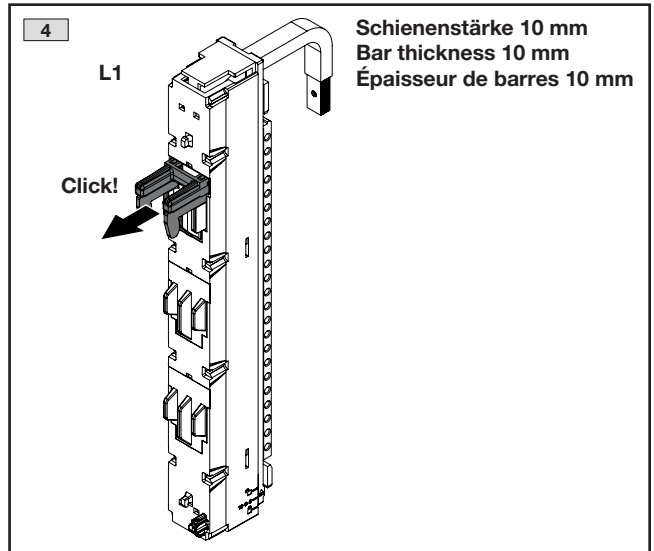
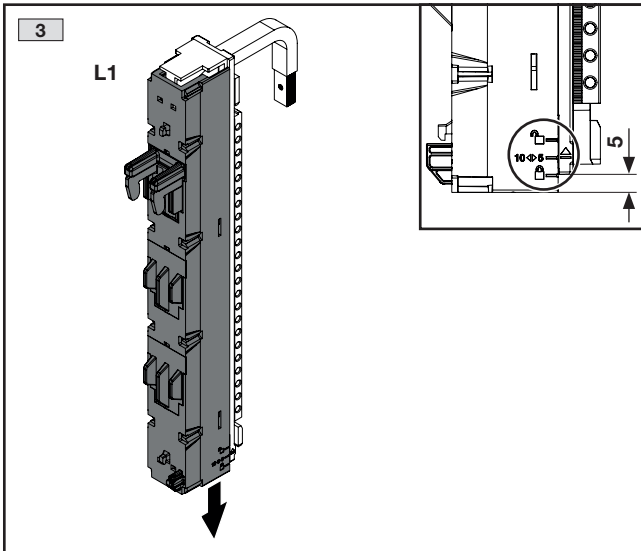
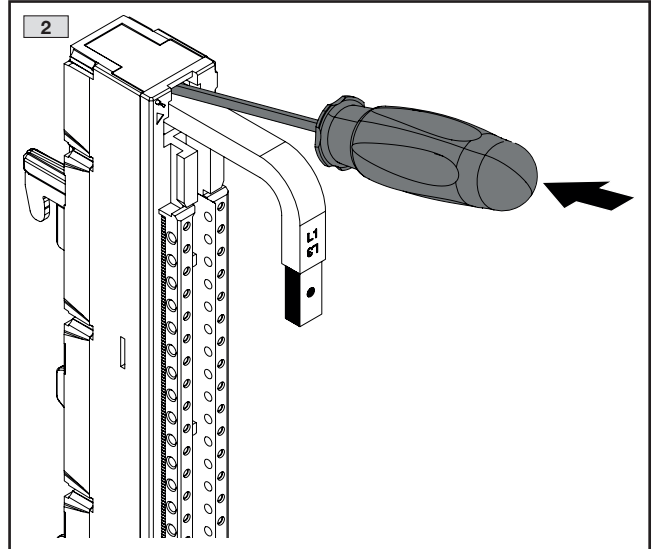
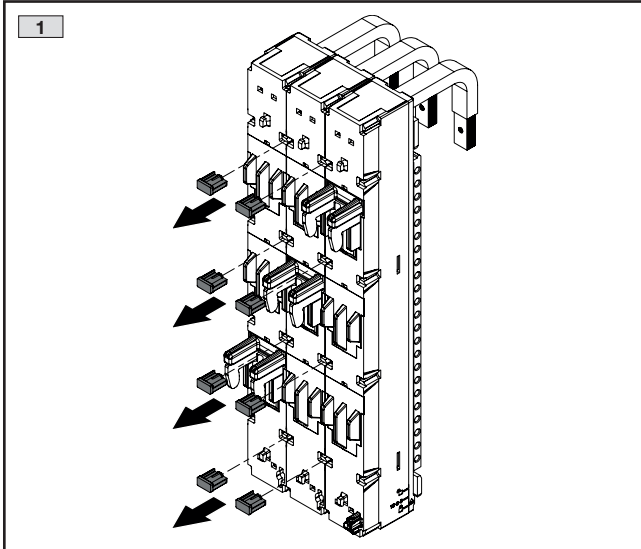

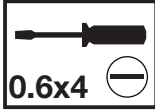
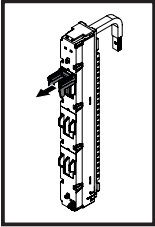

0.6x4

DE EN FR



3. Montage und Aufstellung 9360.500/.503/.600/.603
3. Assembly and siting 9360.500/.503/.600/.603
3. Montage et implantation références 9360.500/.503/.600/.603

3.2 Einstellung Sammelschienenstärke

3.2 Setting the busbar thickness

3.2 Réglage de l'épaisseur des barres de courant

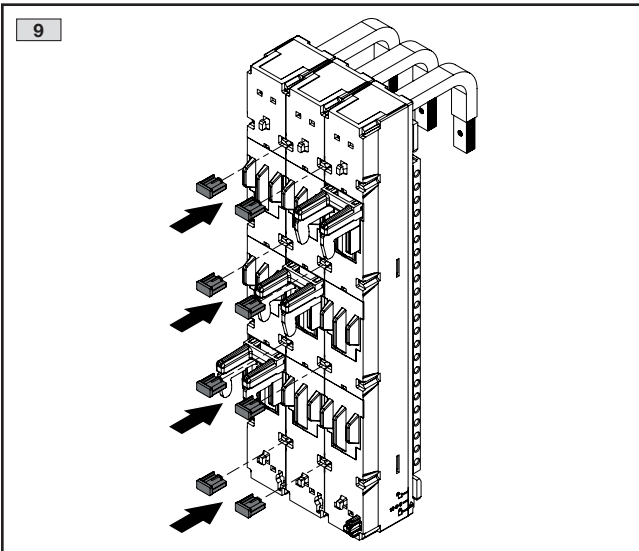
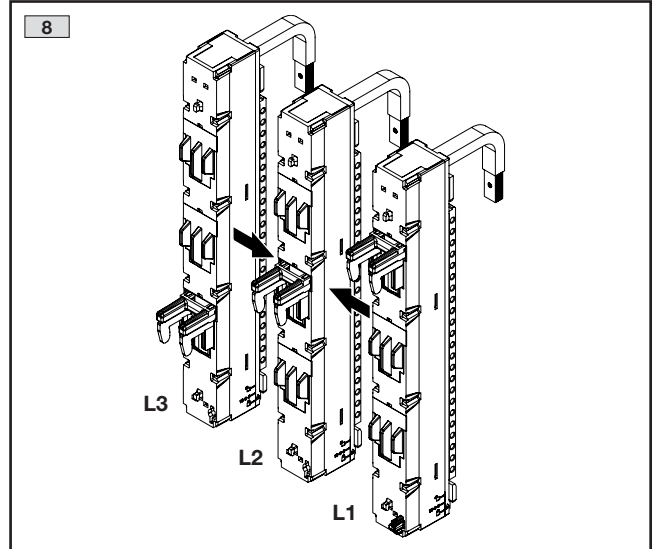
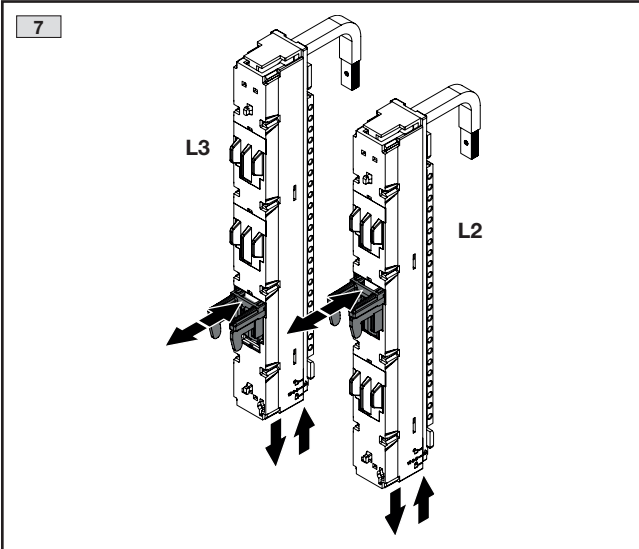

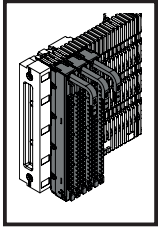

- 3. Montage und Aufstellung 9360.500/.503/.600/.603
- 3. Assembly and siting 9360.500/.503/.600/.603
- 3. Montage et implantation références 9360.500/.503/.600/.603

- 3.3 Montage CB-Geräteadapter
- 3.3 Mounting the circuit-breaker component adaptor
- 3.3 Montage de l'adaptateur de disjoncteur

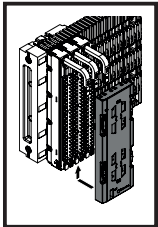
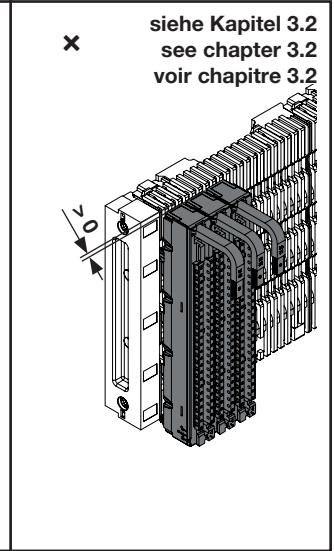
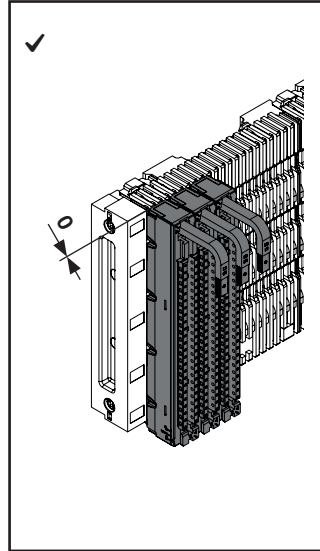
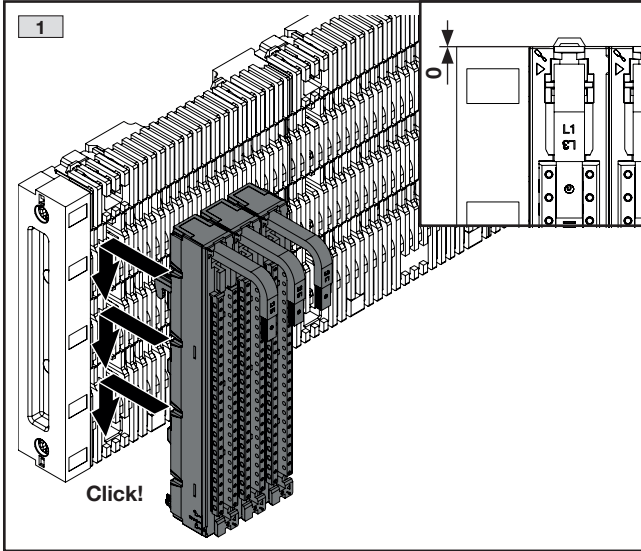

- 3. Montage und Aufstellung 9360.500/.503/.600/.603
- 3. Assembly and siting 9360.500/.503/.600/.603
- 3. Montage et implantation références 9360.500/.503/.600/.603

- 3.4 Einstellung und Montage Easy-fix 9360.500/.503
- 3.4 Setting and mounting the Easy-fix 9360.500/.503
- 3.4 Réglage et montage du système Easy-fix référence 9360.500/.503

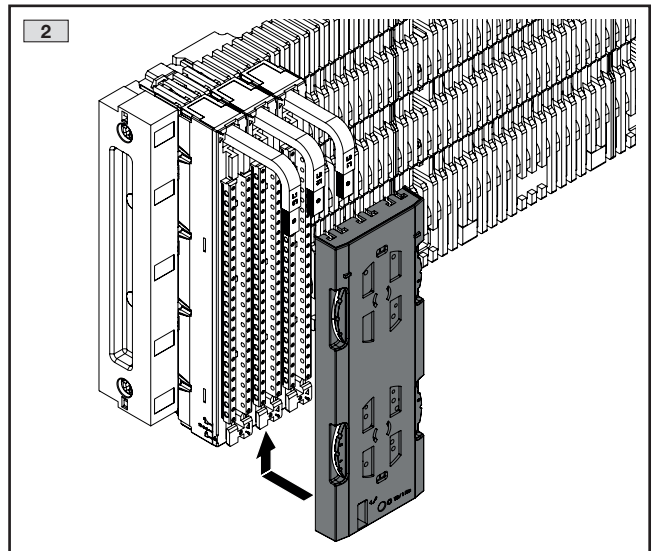
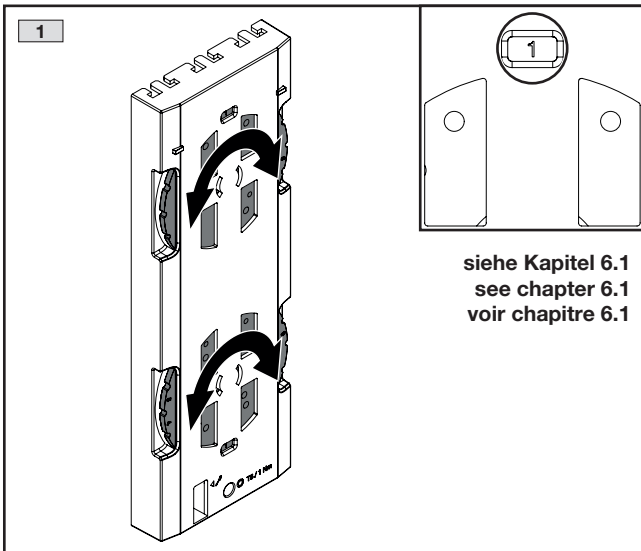

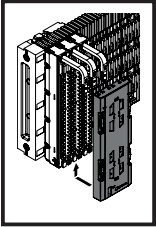

**TX8**



DE EN FR



- 3. Montage und Aufstellung 9360.500/.503/.600/.603
- 3. Assembly and siting 9360.500/.503/.600/.603
- 3. Montage et implantation références 9360.500/.503/.600/.603

- 3.4 Einstellung und Montage Easy-fix 9360.500/.503
- 3.4 Setting and mounting the Easy-fix 9360.500/.503
- 3.4 Réglage et montage du système Easy-fix référence 9360.500/.503

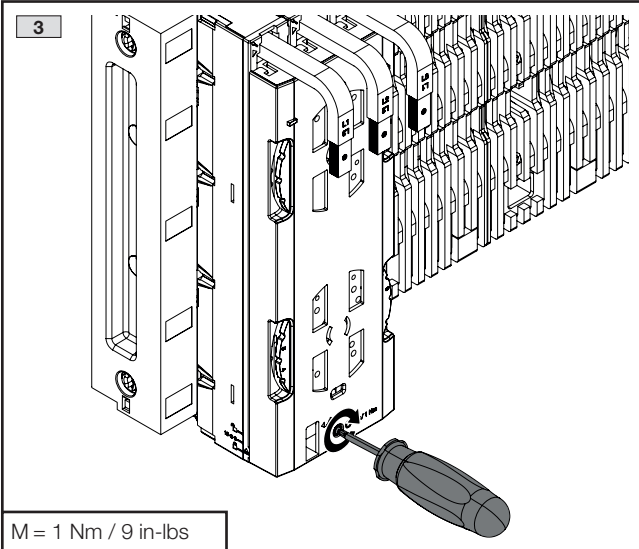

M = 1 Nm / 9 in-lbs

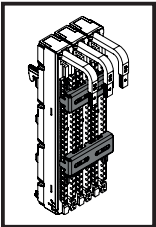

DE EN FR



- 3. Montage und Aufstellung 9360.500/.503/.600/.603
- 3. Assembly and siting 9360.500/.503/.600/.603
- 3. Montage et implantation références 9360.500/.503/.600/.603

- 3.5 Montage und Demontage Universal-fix 9360.600/.603
- 3.5 Mounting and dismantling the Universal-fix 9360.600/.603
- 3.5 Montage et démontage du système Universal-fix référence 9360.600/.603

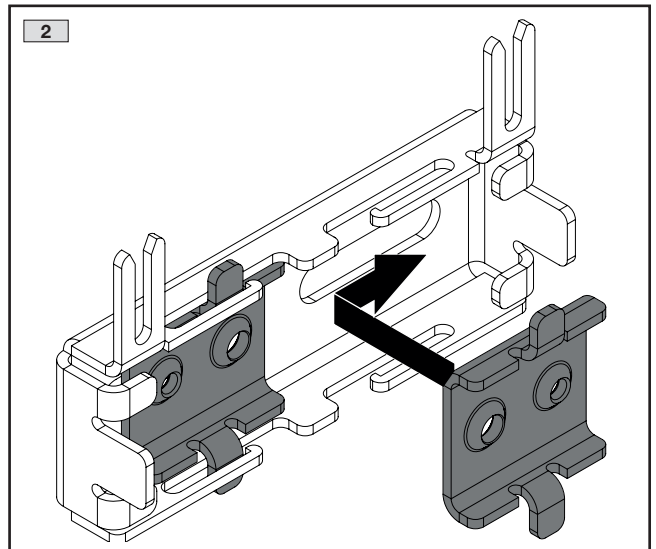
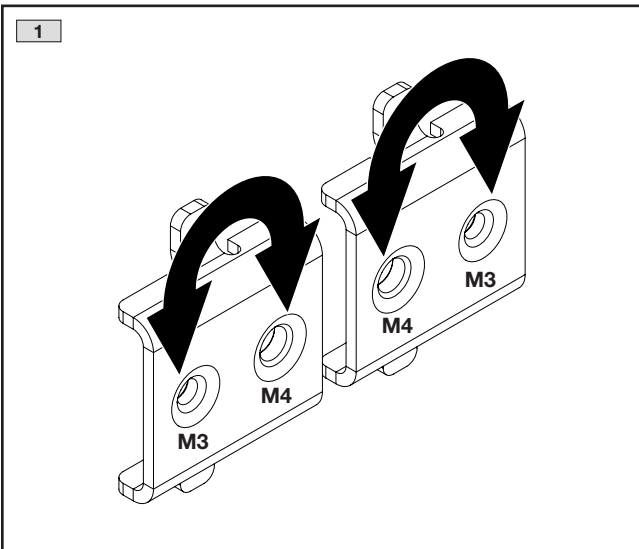

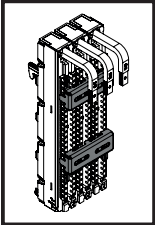

**TX8**



DE EN FR



3. Montage und Aufstellung 9360.500/.503/.600/.603
3. Assembly and siting 9360.500/.503/.600/.603
3. Montage et implantation références 9360.500/.503/.600/.603

3.5 Montage und Demontage Universal-fix 9360.600/.603

3.5 Mounting and dismantling the Universal-fix 9360.600/.603

3.5 Montage et démontage du système Universal-fix référence 9360.600/.603

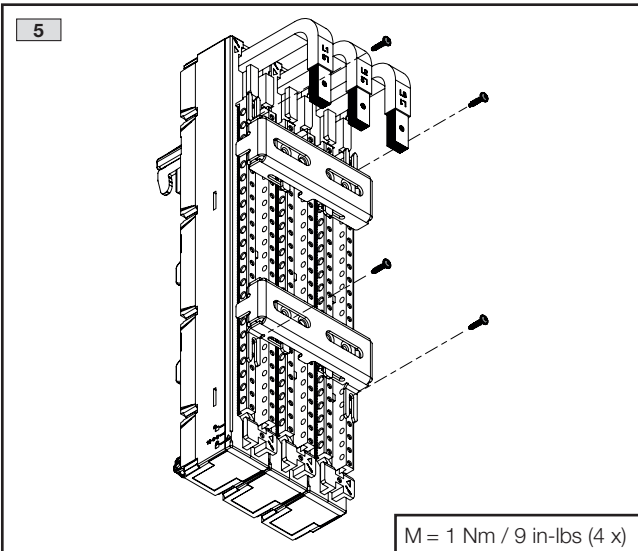
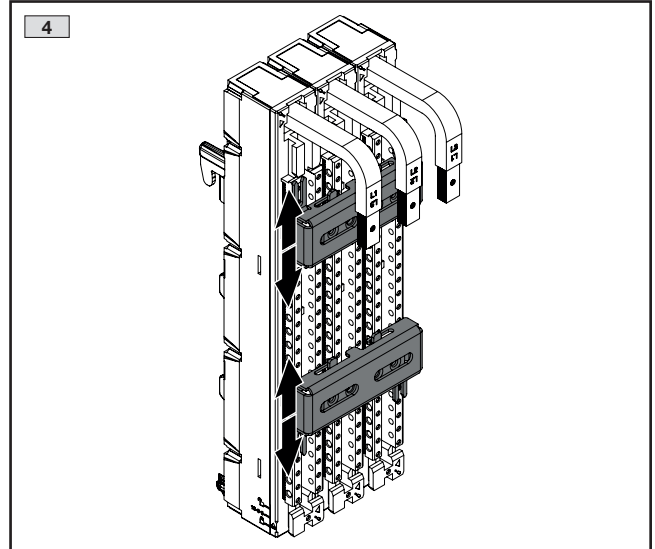
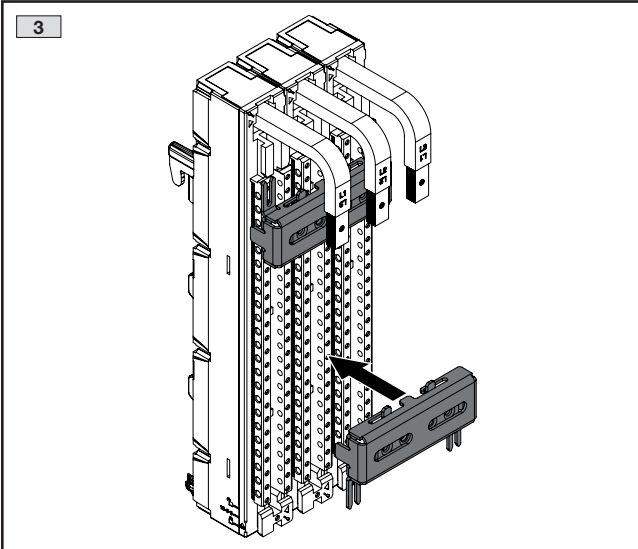

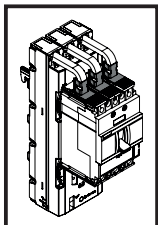

- 3. Montage und Aufstellung 9360.500/.503/.600/.603
- 3. Assembly and siting 9360.500/.503/.600/.603
- 3. Montage et implantation références 9360.500/.503/.600/.603

- 3.6 Montage Anschlussraumabdeckung
- 3.6 Mounting the connection space cover
- 3.6 Montage du capot recouvrant la zone de raccordement

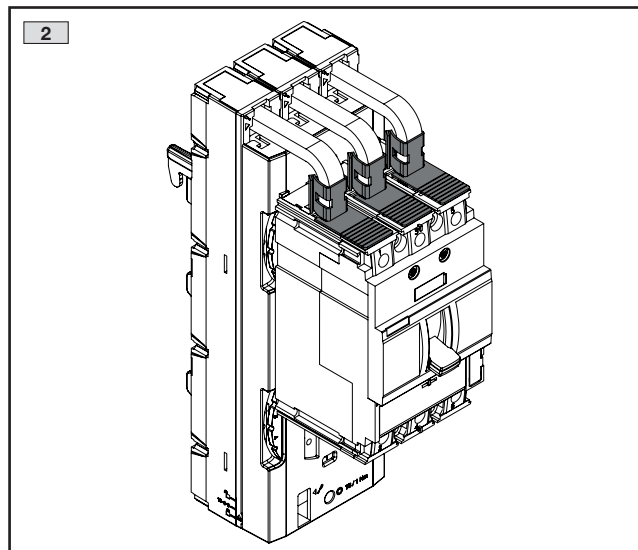
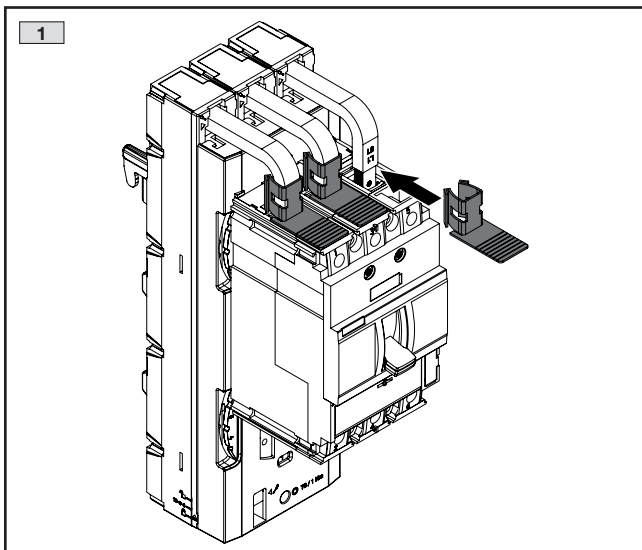

**Hinweis:**  
Montage der Anschlussraumabdeckung unter Berücksichtigung der Vorgaben des Schaltgeräteherstellers.

**Note:**  
Mounting the connection space cover taking into account the specifications of the switchgear manufacturer.

**Remarque :**  
Montage du capot recouvrant la zone de raccordement en tenant compte des spécifications du fabricant de l'appareillage.

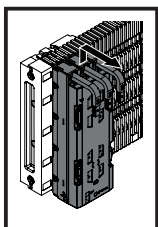

- 3. Montage und Aufstellung 9360.500/.503/.600/.603
- 3. Assembly and siting 9360.500/.503/.600/.603
- 3. Montage et implantation références 9360.500/.503/.600/.603

- 3.7 Demontage CB-Geräteadapter
- 3.7 Dismantling the circuit-breaker component adaptor
- 3.7 Démontage de l'adaptateur de disjoncteur

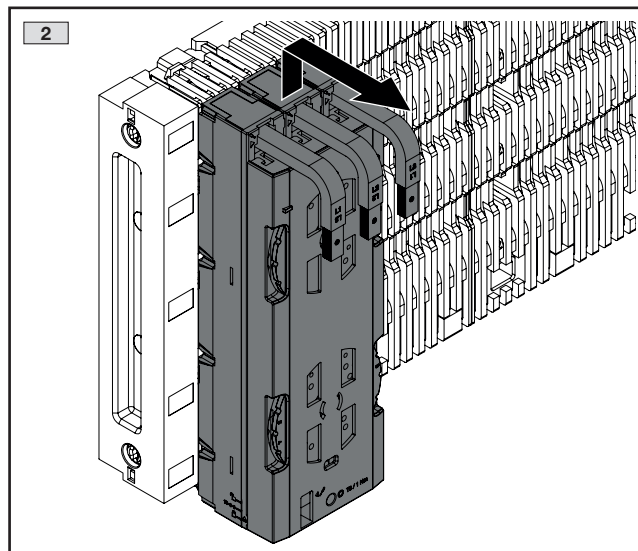
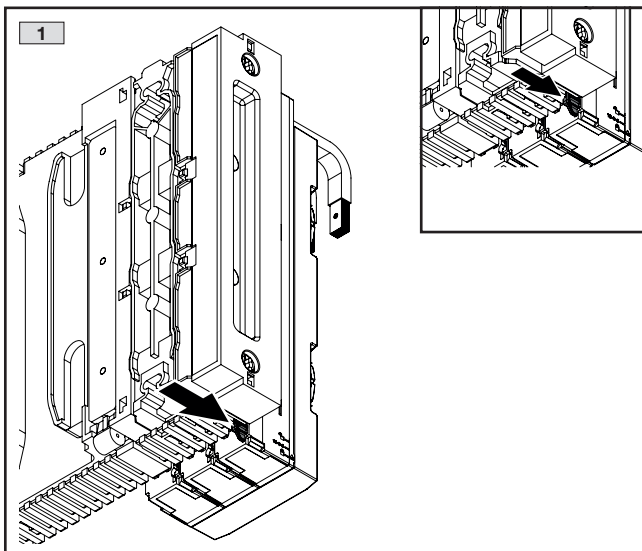

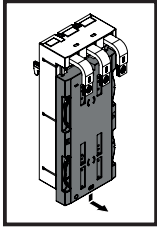

TX8

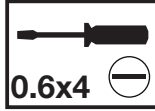

- 4. Montage und Aufstellung 9360.512/.513/.612/.613
- 4. Assembly and siting 9360.512/.513/.612/.613
- 4. Montage et implantation références 9360.512/.513/.612/.613

4.1 Demontage Easy-fix 9360.512/.513

4.1 Dismantling the Easy-fix 9360.512/.513

4.1 Démontage du système Easy-fix référence 9360.512/.513

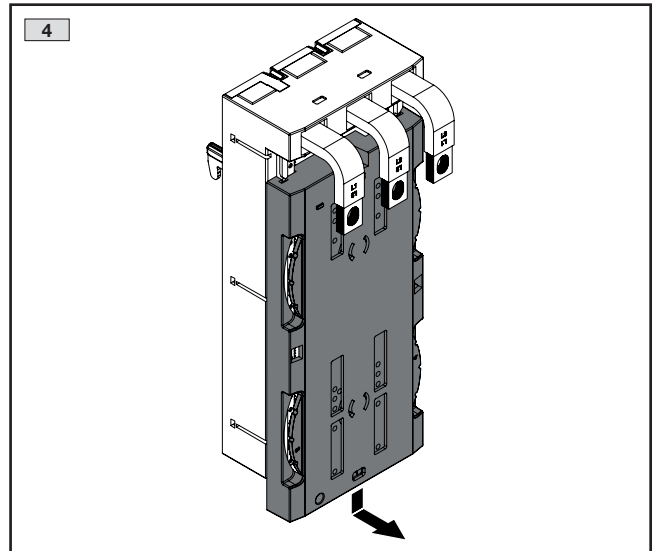
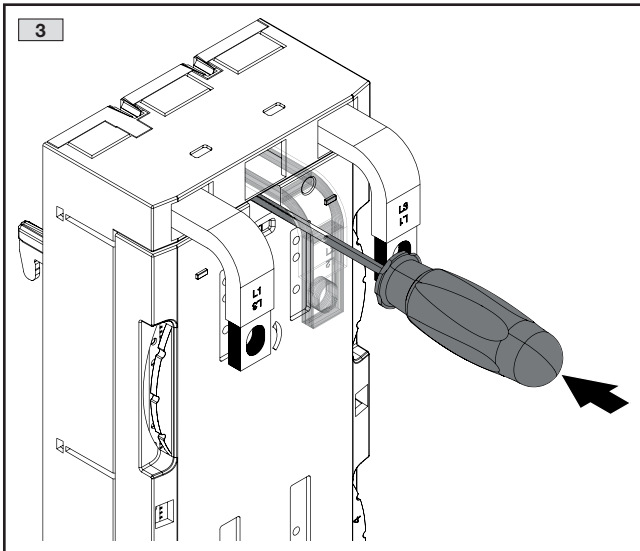
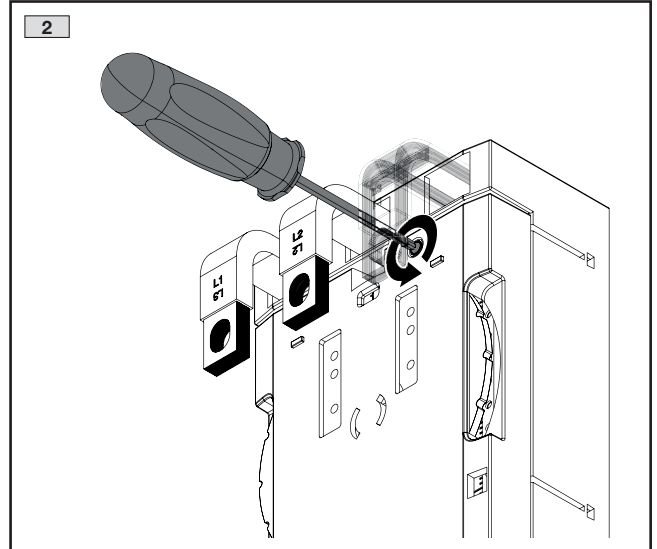
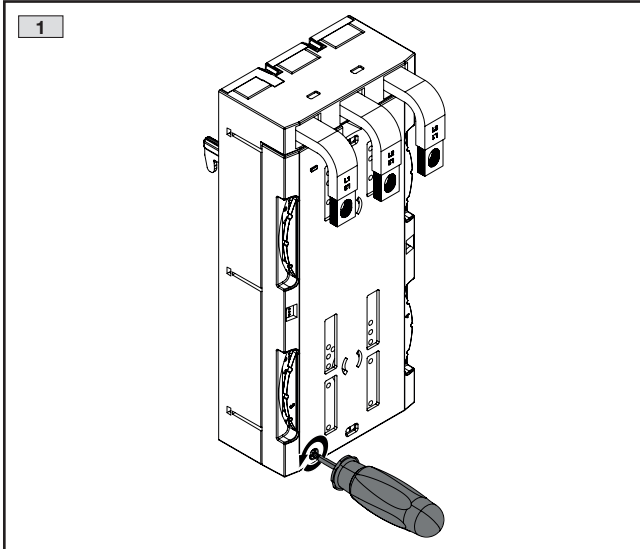

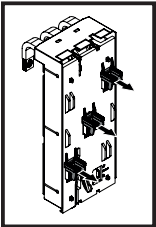

- 4. Montage und Aufstellung 9360.512/.513/.612/.613
- 4. Assembly and siting 9360.512/.513/.612/.613
- 4. Montage et implantation références 9360.512/.513/.612/.613

- 4.2 Einstellung Sammelschienenstärke
- 4.2 Setting the busbar thickness
- 4.2 Réglage de l'épaisseur des barres de courant

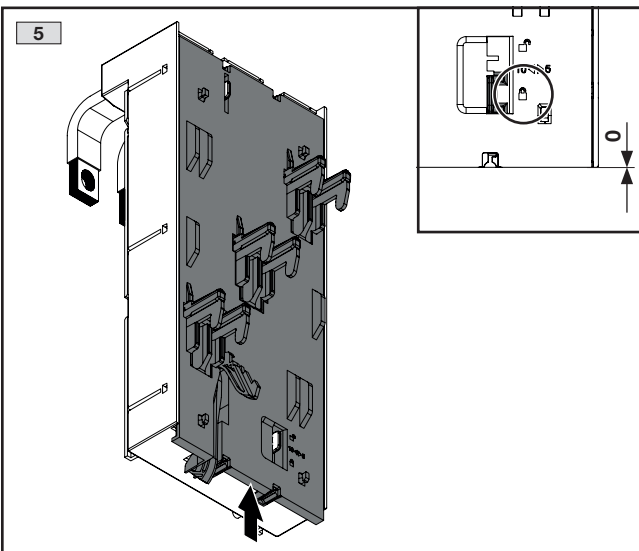
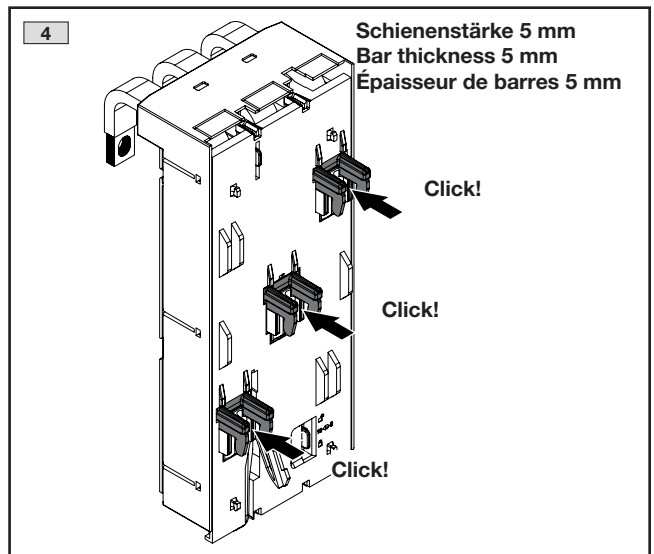
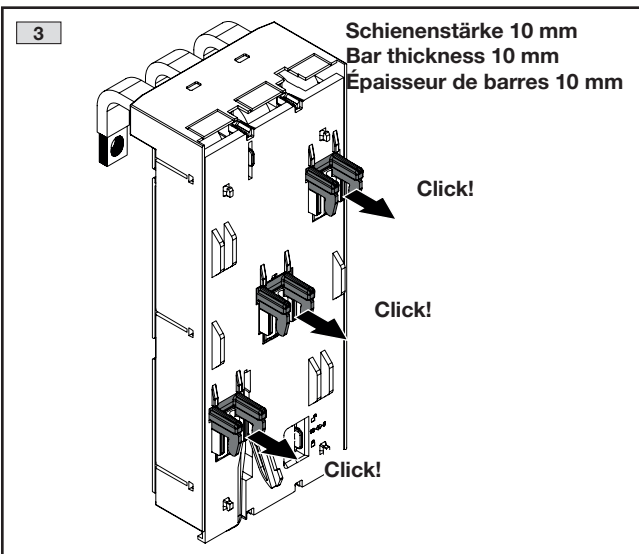
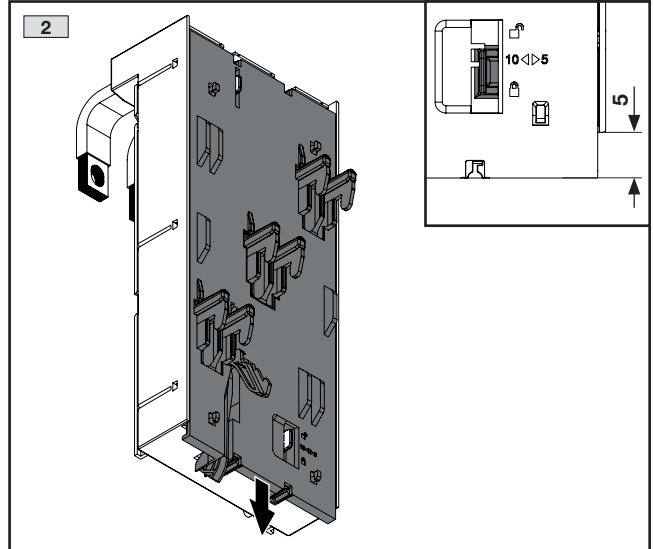
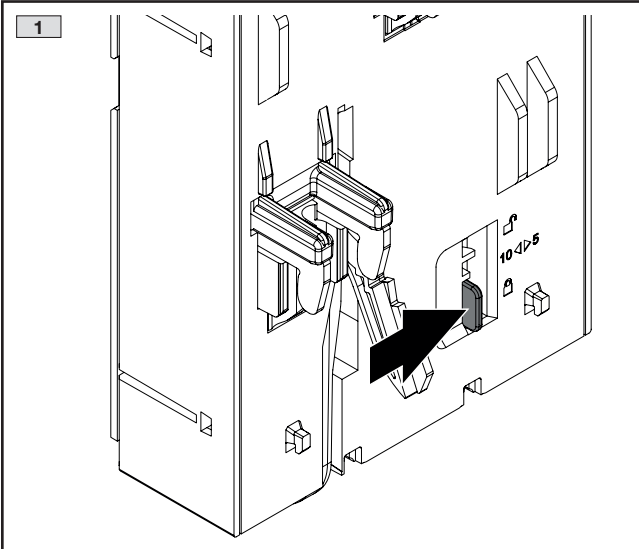

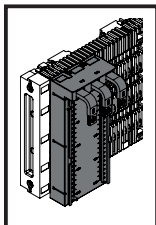

- 4. Montage und Aufstellung 9360.512/.513/.612/.613
- 4. Assembly and siting 9360.512/.513/.612/.613
- 4. Montage et implantation références 9360.512/.513/.612/.613

4.3 Montage CB-Geräteadapter

4.3 Mounting the circuit-breaker component adaptor

4.3 Montage de l'adaptateur de disjoncteur

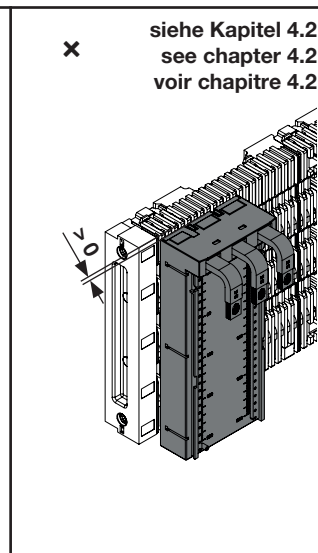
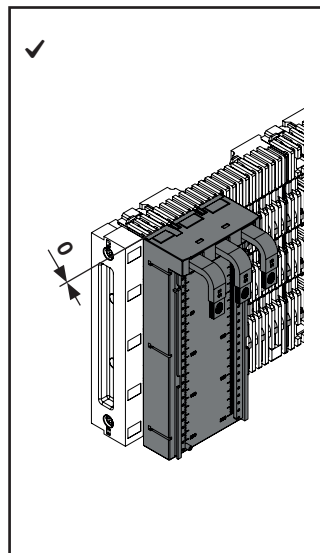
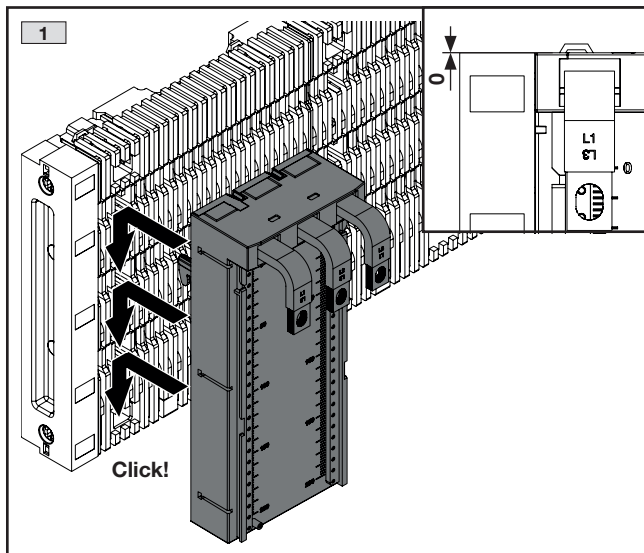

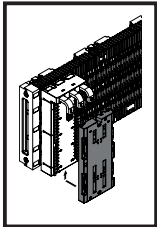

TX8



DE EN FR



- 4. Montage und Aufstellung 9360.512/.513/.612/.613
- 4. Assembly and siting 9360.512/.513/.612/.613
- 4. Montage et implantation références 9360.512/.513/.612/.613

4.4 Einstellung und Montage Easy-fix 9360.512/.513

4.4 Setting and mounting the Easy-fix 9360.512/.513

4.4 Réglage et montage du système Easy-fix référence 9360.512/.513

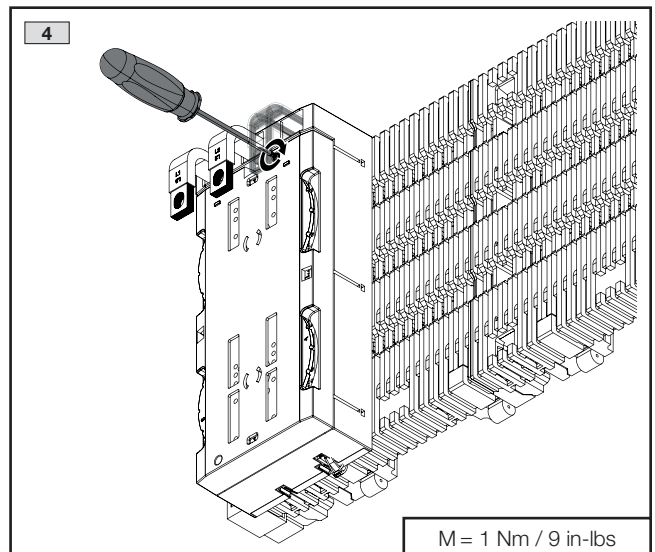
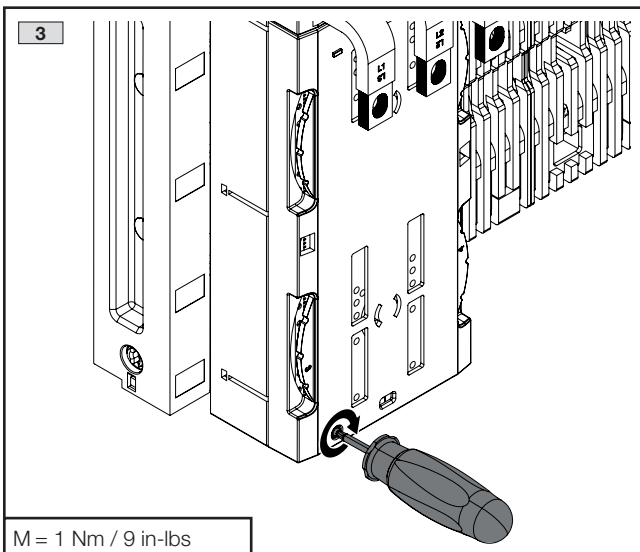
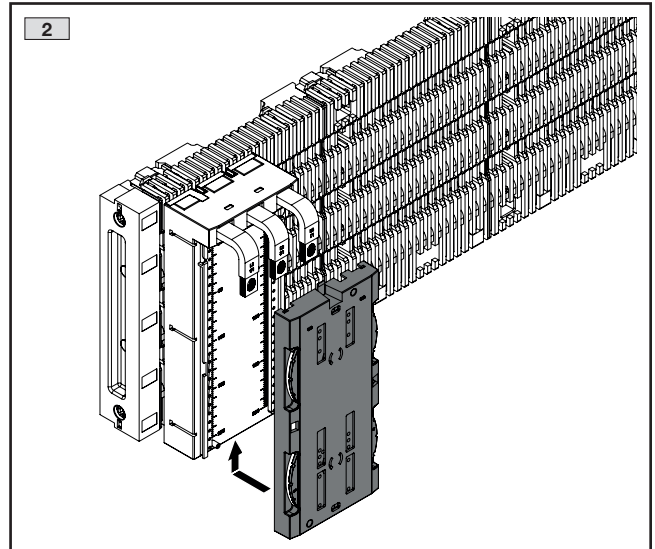
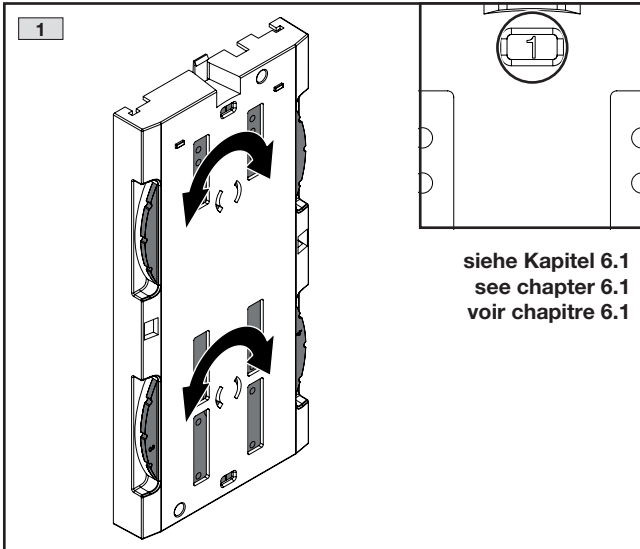

**Hinweis:**

Montage der Anschlussraumabdeckung unter Berücksichtigung der Vorgaben des Schaltgeräteherstellers (siehe Kapitel 3.6).

**Note:**

Mounting the connection space cover taking into account the specifications of the switchgear manufacturer (see section 3.6).

**Remarque :**

Montage du capot recouvrant la zone de raccordement en tenant compte des spécifications du fabricant de l'appareillage (voir chapitre 3.6).

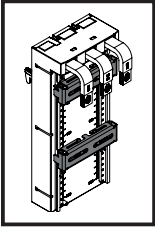

**TX8**



DE EN FR



- 4. Montage und Aufstellung 9360.512/.513/.612/.613
- 4. Assembly and siting 9360.512/.513/.612/.613
- 4. Montage et implantation références 9360.512/.513/.612/.613

- 4.5 Montage und Demontage Universal-fix 9360.612/.613
- 4.5 Mounting and dismantling the Universal-fix 9360.612/.613
- 4.5 Montage et démontage du système Universal-fix référence 9360.612/.613

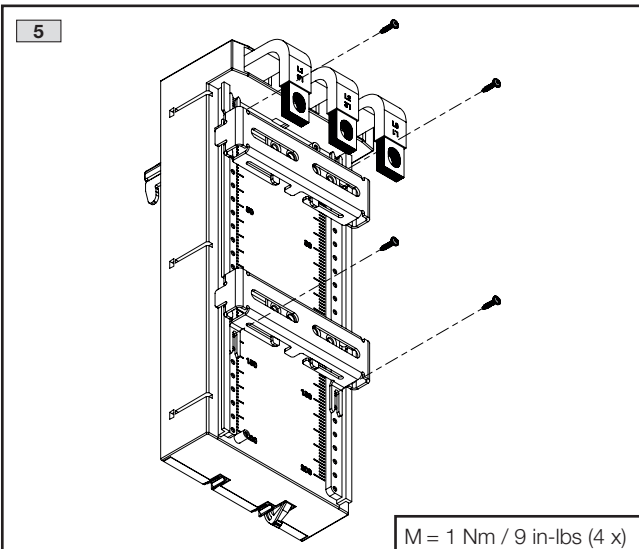
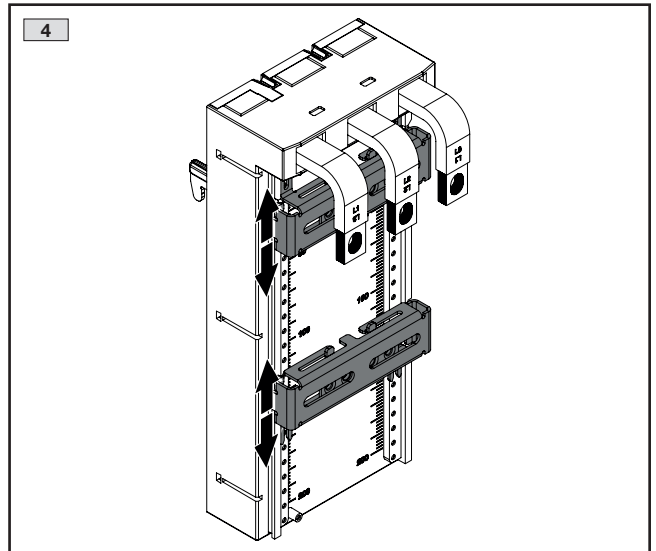
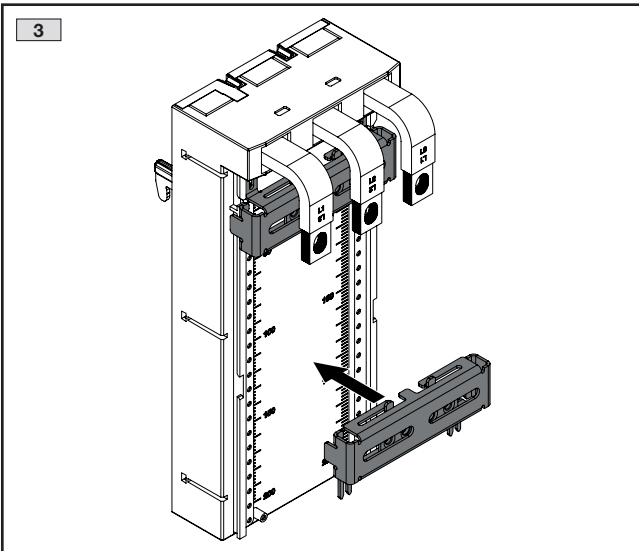
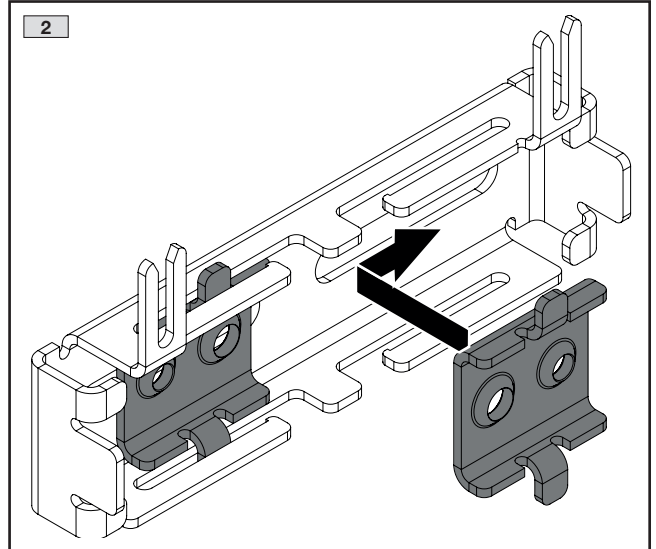
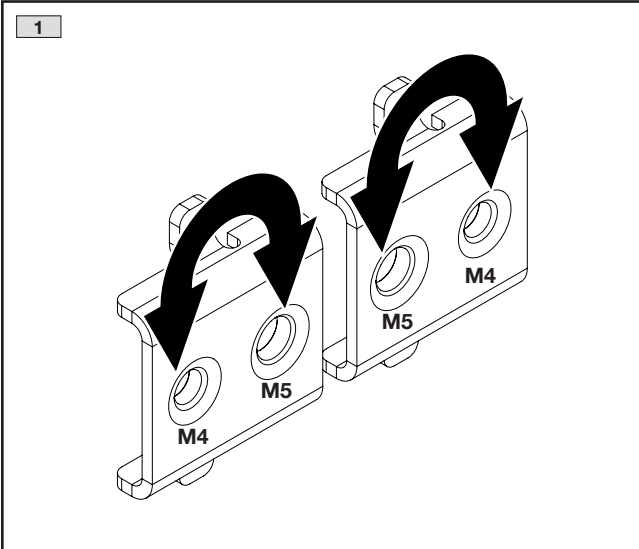

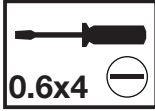
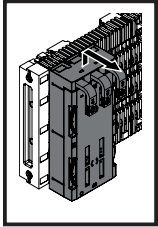

- 4. Montage und Aufstellung 9360.512/.513/.612/.613
- 4. Assembly and siting 9360.512/.513/.612/.613
- 4. Montage et implantation références 9360.512/.513/.612/.613

4.5 Montage und Demontage Universal-fix 9360.612/.613

4.5 Mounting and dismantling the Universal-fix 9360.612/.613

4.5 Montage et démontage du système Universal-fix référence 9360.612/.613

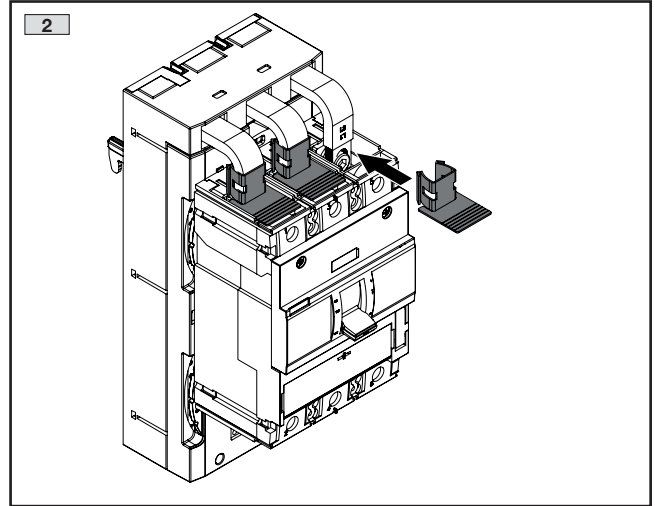
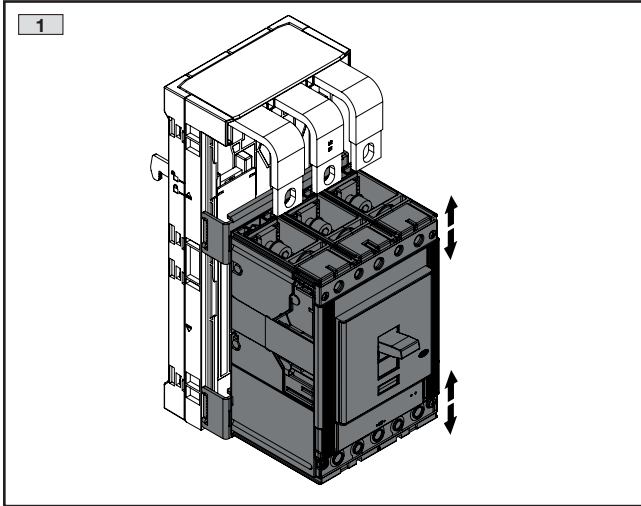

4.6 Demontage CB-Geräteadapter

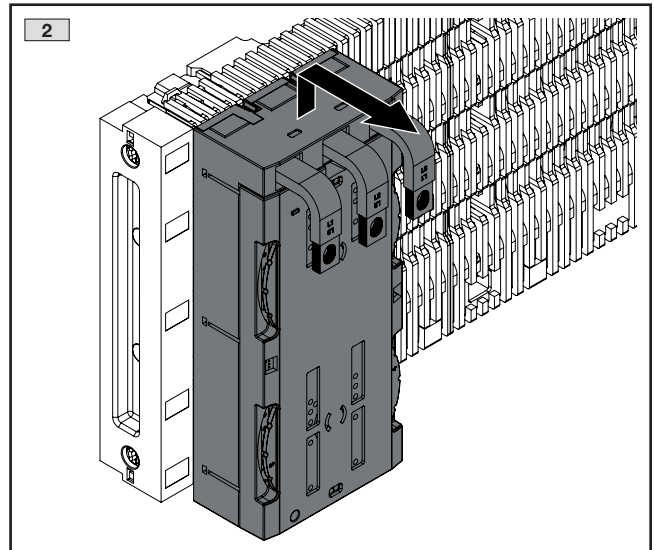
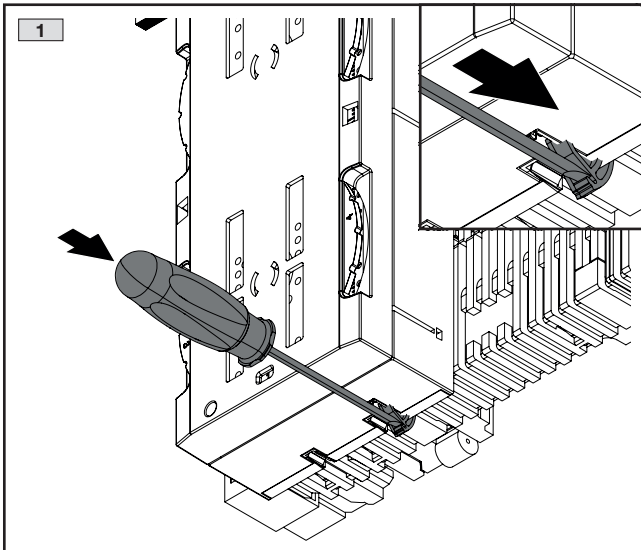

4.6 Dismantling the circuit-breaker component adaptor

4.6 Démontage de l'adaptateur de disjoncteur

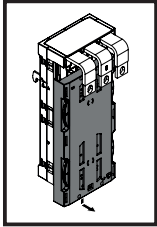



TX20  

  
0.6x4 



- 5. Montage und Aufstellung 9360.525/.535/.625/.635
- 5. Assembly and siting 9360.525/.535/.625/.635
- 5. Montage et implantation références 9360.525/.535/.625/.635

5.1 Demontage Easy-fix 9360.525/.535

5.1 Dismantling the Easy-fix 9360.525/.535

5.1 Démontage du système Easy-fix références 9360.525/.535

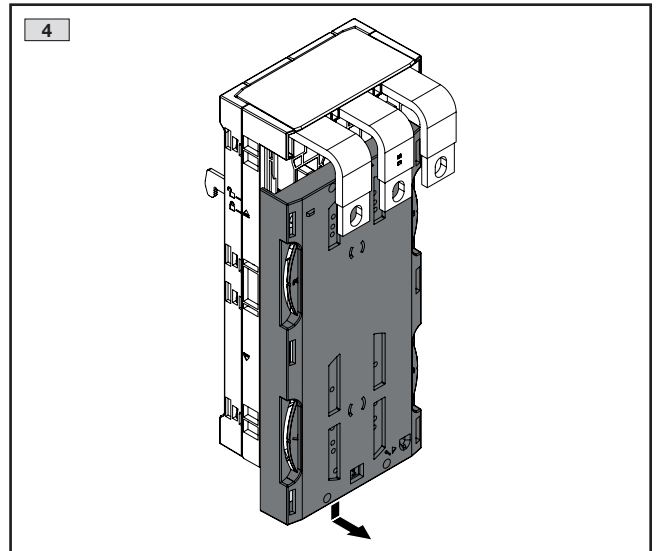
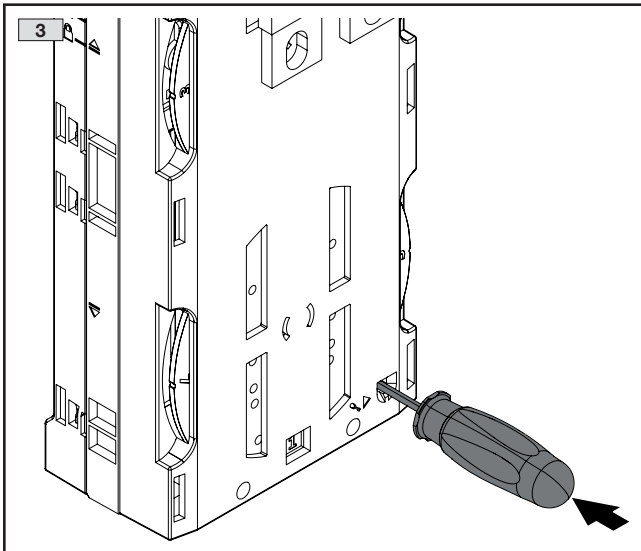
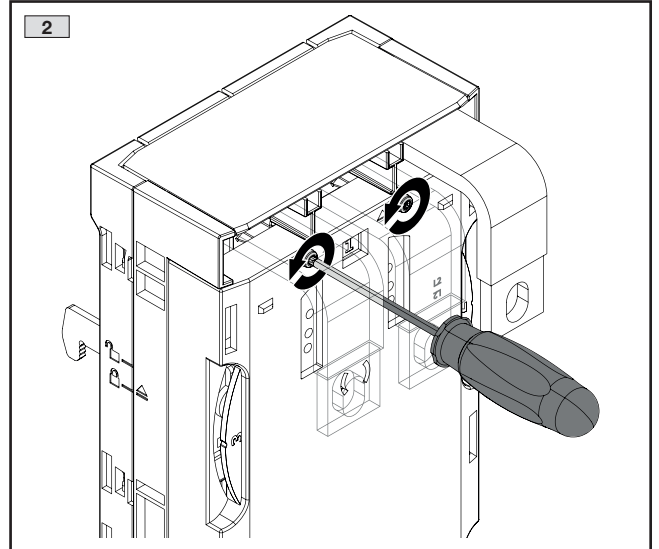
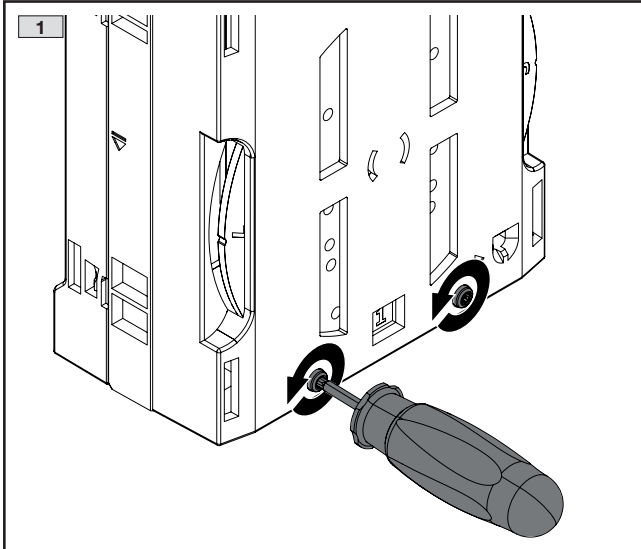

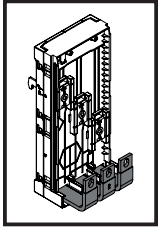

**5. Montage und Aufstellung 9360.525/.535/.625/.635**  
**5. Assembly and siting 9360.525/.535/.625/.635**  
**5. Montage et implantation références 9360.525/.535/.625/.635**

5.2 Drehung Kabelabgang

5.2 Rotation of cable outlet

5.2 Inversion du sens de sortie des câbles

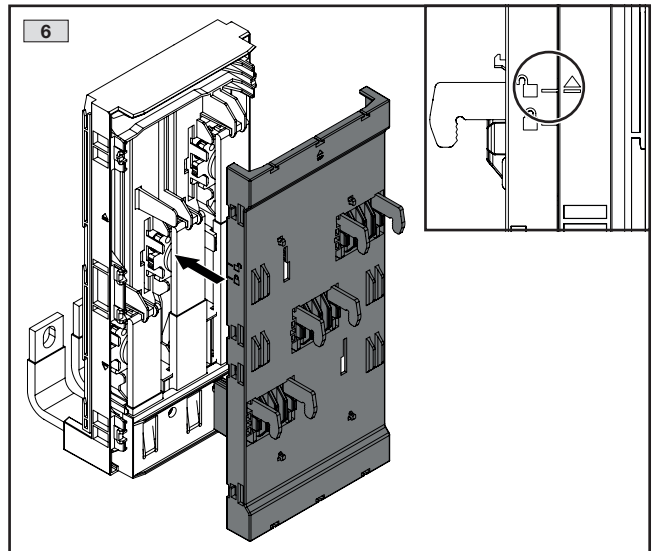
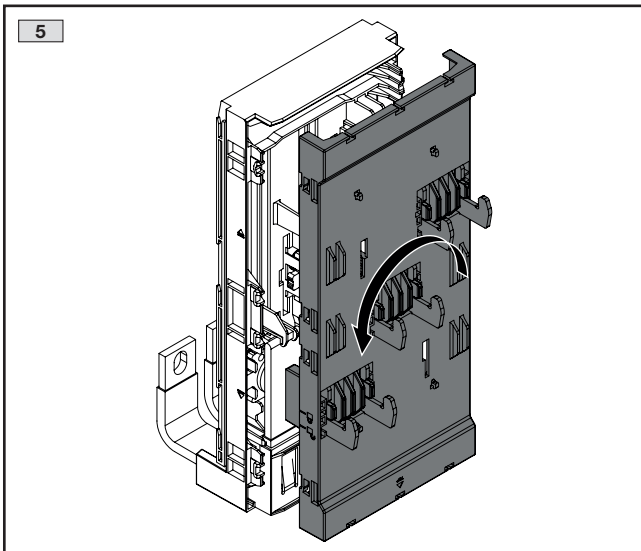
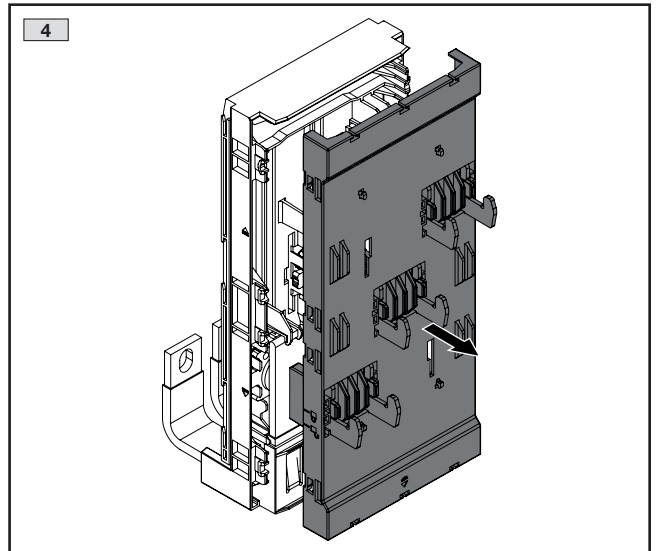
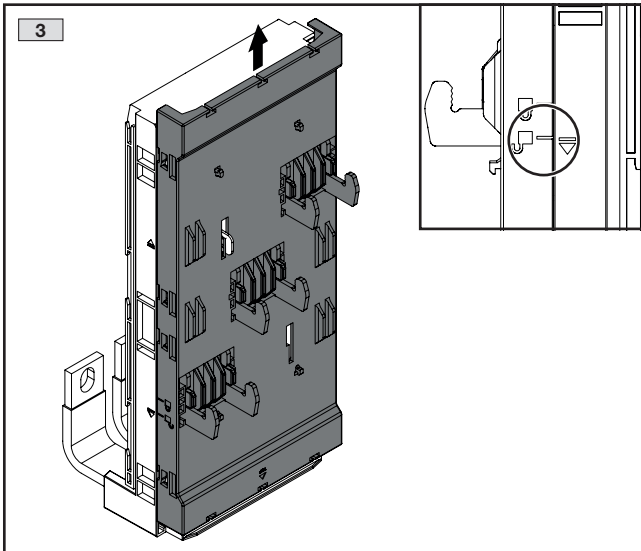
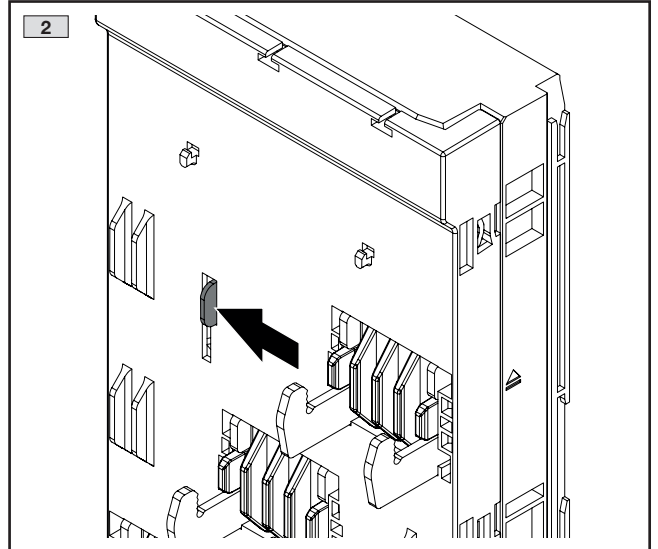
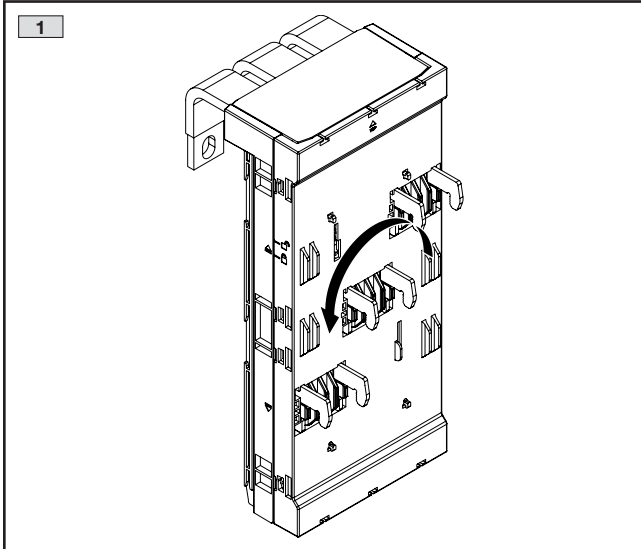

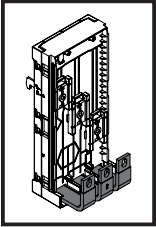

- 5. Montage und Aufstellung 9360.525/.535/.625/.635
- 5. Assembly and siting 9360.525/.535/.625/.635
- 5. Montage et implantation références 9360.525/.535/.625/.635

- 5.2 Drehung Kabelabgang
- 5.2 Rotation of cable outlet
- 5.2 Inversion du sens de sortie des câbles

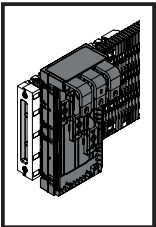
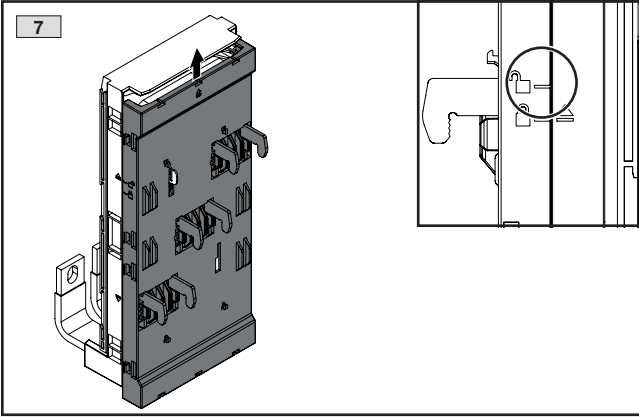

**TX30**



- 5. Montage und Aufstellung 9360.525/.535/.625/.635
- 5. Assembly and siting 9360.525/.535/.625/.635
- 5. Montage et implantation références 9360.525/.535/.625/.635

- 5.3 Montage CB-Geräteadapter
- 5.3 Mounting the circuit-breaker component adaptor
- 5.3 Montage de l'adaptateur de disjoncteur

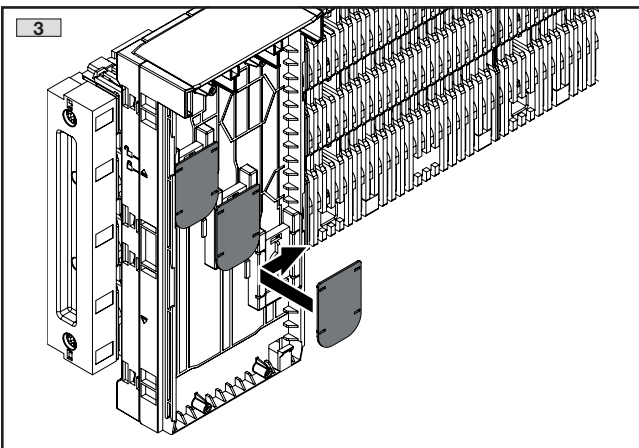
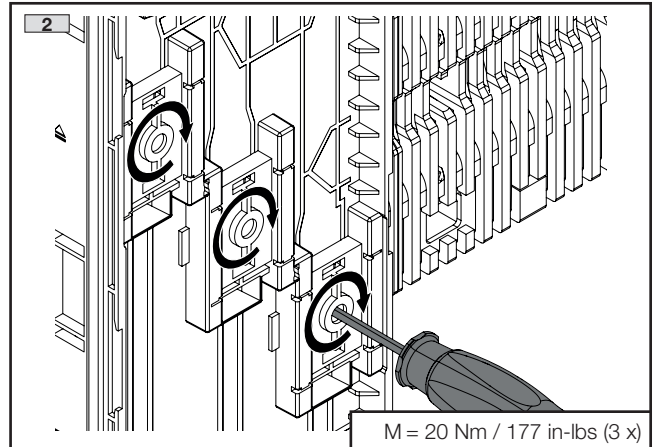
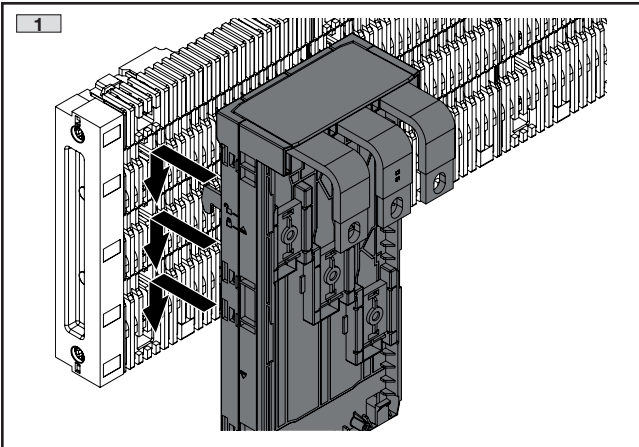

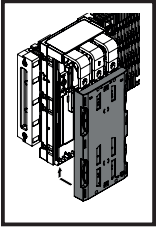

**TX20**

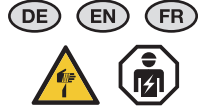
- 5. Montage und Aufstellung 9360.525/.535/.625/.635
- 5. Assembly and siting 9360.525/.535/.625/.635
- 5. Montage et implantation références 9360.525/.535/.625/.635

- 5.4 Einstellung und Montage Easy-fix
- 5.4 Setting and mounting the Easy-fix
- 5.4 Réglage et montage du système Easy-fix

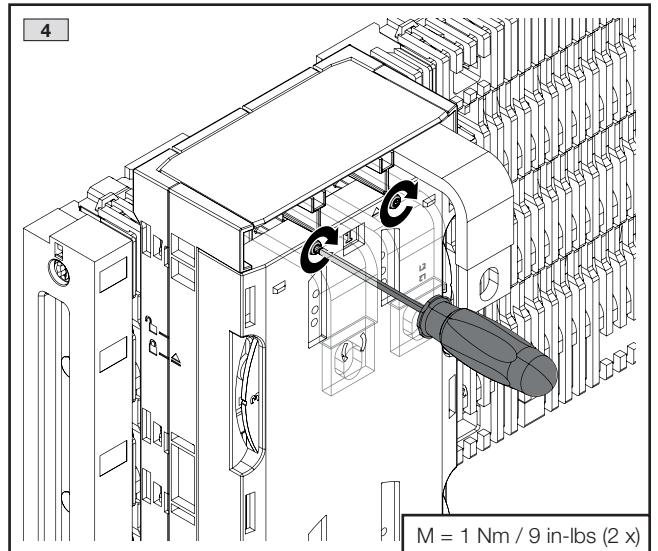
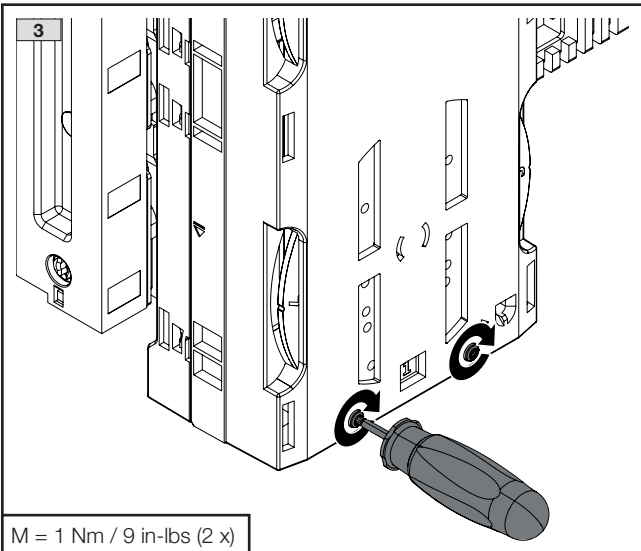
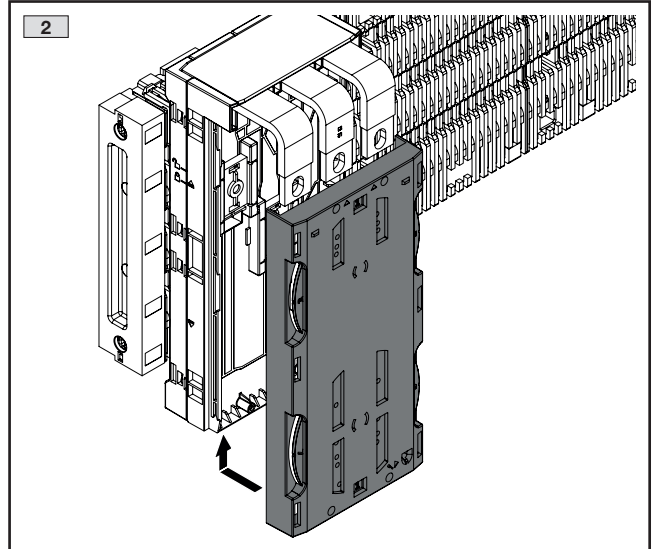
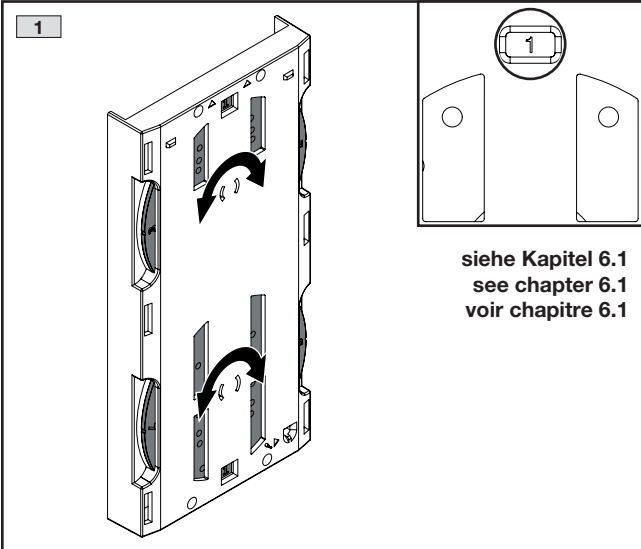

**i Hinweis:**  
Montage der Anschlussraumabdeckung unter Berücksichtigung der Vorgaben des Schaltgeräteherstellers (siehe Kapitel 3.6).

**Note:**  
Mounting the connection space cover taking into account the specifications of the switchgear manufacturer (see section 3.6).

**Remarque :**  
Montage du capot recouvrant la zone de raccordement en tenant compte des spécifications du fabricant de l'appareillage (voir chapitre 3.6).

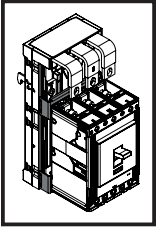

5. Montage und Aufstellung 9360.525/.535/.625/.635  
 5. Assembly and siting 9360.525/.535/.625/.635  
 5. Montage et implantation références 9360.525/.535/.625/.635

5.5 Montage und Demontage Universal-fix 9360.625/.635

5.5 Mounting and dismantling the Universal-fix 9360.625/.635

5.5 Montage et démontage du système Universal-fix référence 9360.625/.635

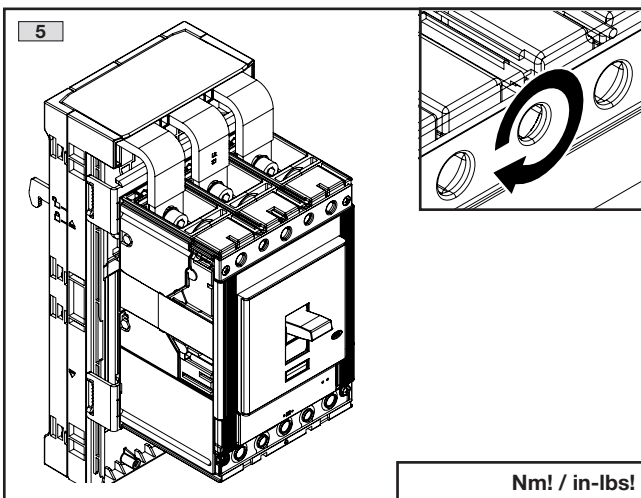
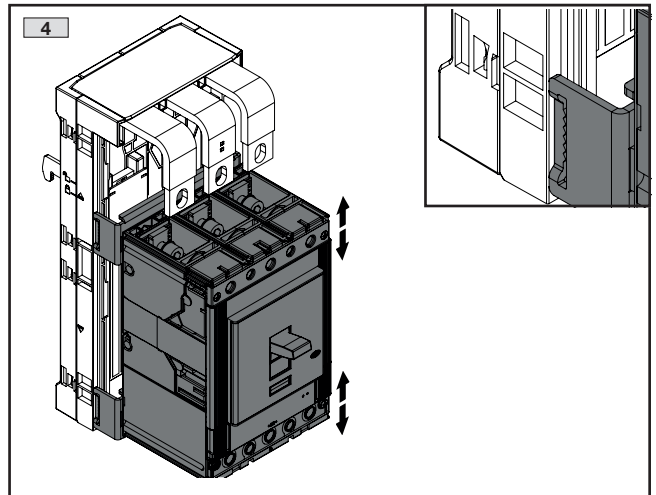
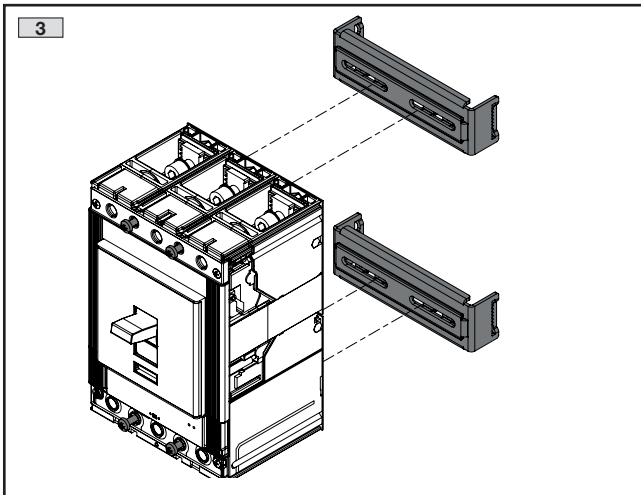
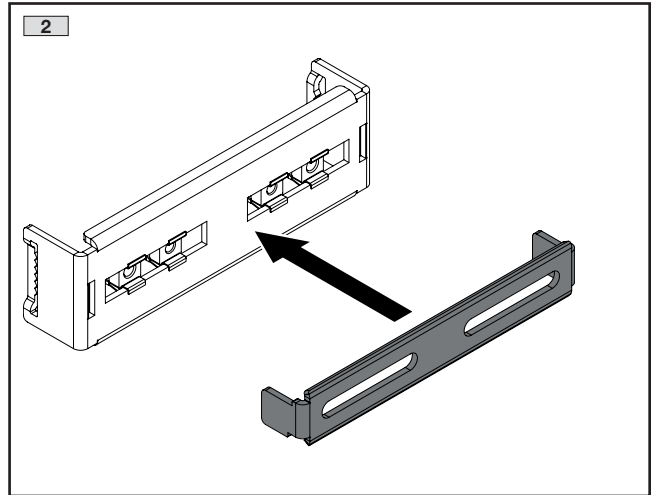
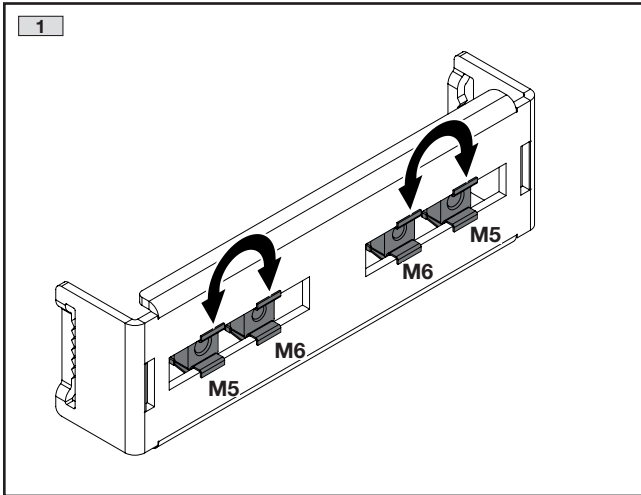

Nm! / in-lbs!

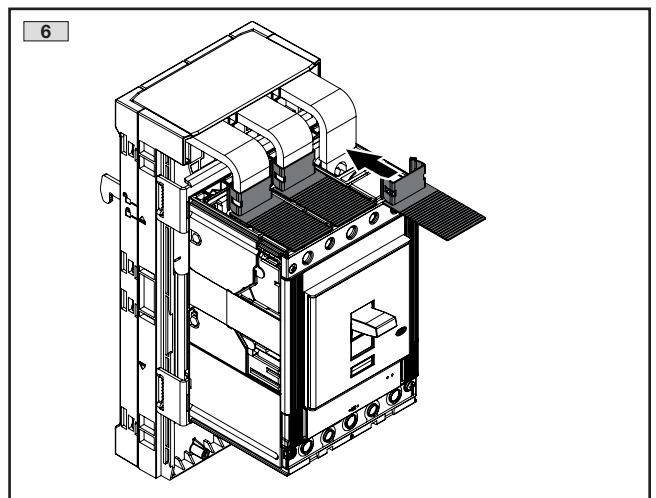

**Hinweis:**

Drehmoment zur Befestigung unter Berücksichtigung der Vorgaben des Schaltgeräteherstellers.

**Note:**

Torque for fastening according to the specifications of the switchgear manufacturer.

**Remarque :**

Couple de serrage nécessaire pour la fixation du disjoncteur d'après les spécifications du fabricant.

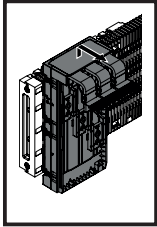

TX20



0.6x4



DE EN FR



5. Montage und Aufstellung 9360.525/.535/.625/.635
5. Assembly and siting 9360.525/.535/.625/.635
5. Montage et implantation références 9360.525/.535/.625/.635

5.6 Demontage CB-Geräteadapter

5.6 Dismantling the circuit-breaker component adaptor

5.6 Démontage de l'adaptateur de disjoncteur

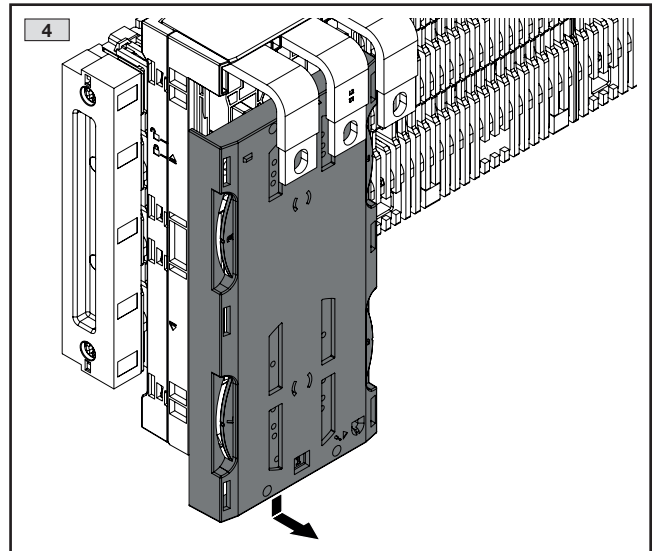
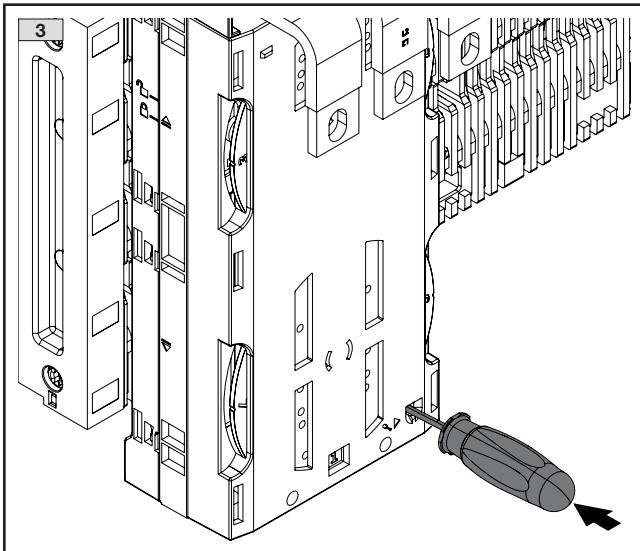
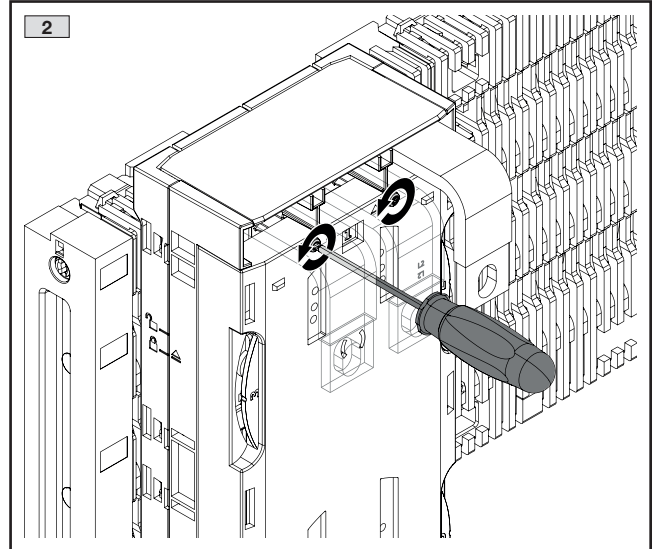
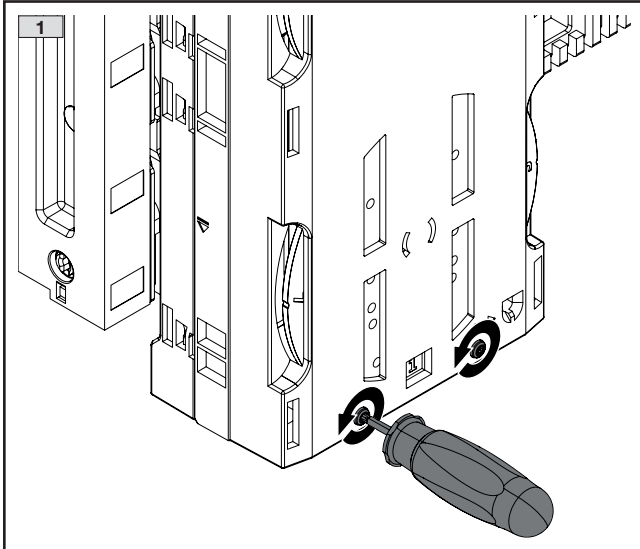

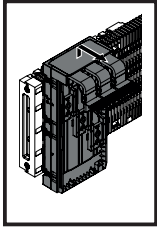

**TX30**



DE EN FR



5. Montage und Aufstellung 9360.525/.535/.625/.635
5. Assembly and siting 9360.525/.535/.625/.635
5. Montage et implantation références 9360.525/.535/.625/.635

- 5.6 Demontage CB-Geräteadapter
- 5.6 Dismantling the circuit-breaker component adaptor
- 5.6 Démontage de l'adaptateur de disjoncteur

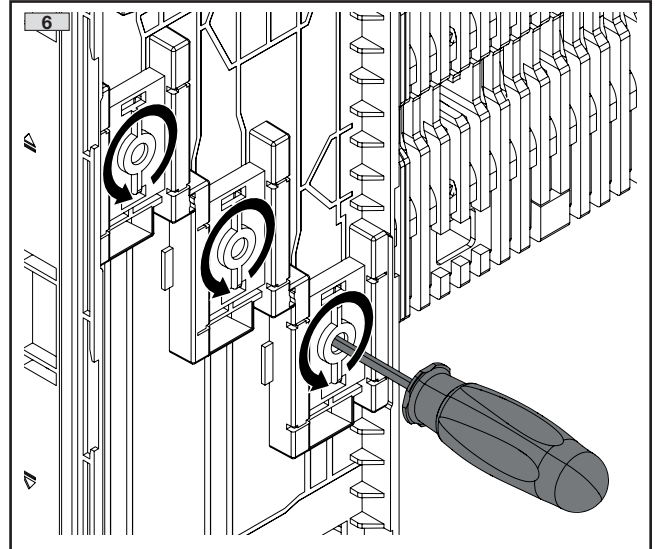
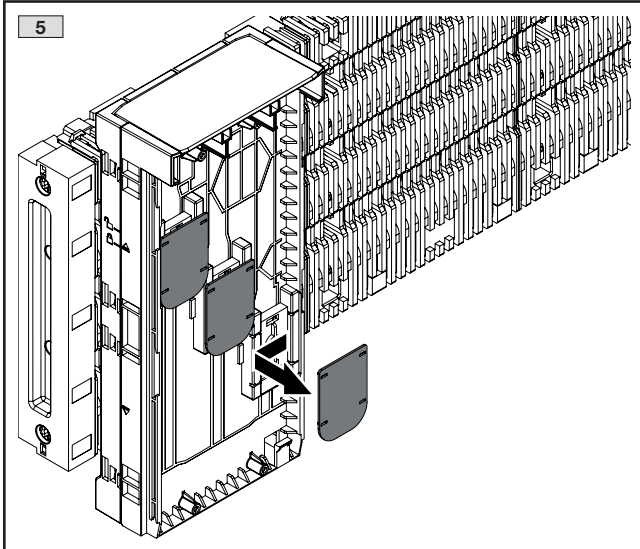

- i** **Hinweis:**  
Schrauben nicht zu weit lösen.
- Note:**  
Do not loosen the screws too far.
- Remarque :**  
Ne desserrez pas trop les vis.

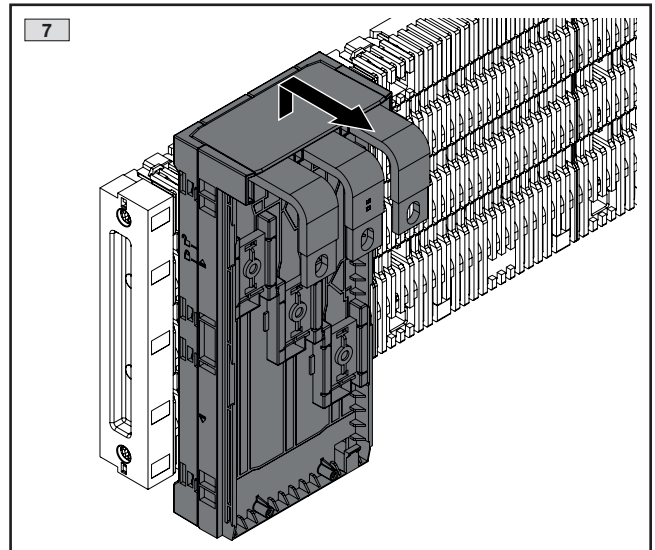

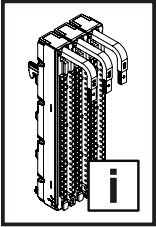

6. Hinweise zur Gerätemontage auf Easy-fix/Universal-fix  
 6. Notes on device installation on Easy-fix/Universal-fix  
 6. Remarques sur l'installation des appareils sur les systèmes Easy-fix/Universal-fix

- 6.1 Easy-fix
- 6.1 Easy-fix
- 6.1 Système Easy-fix

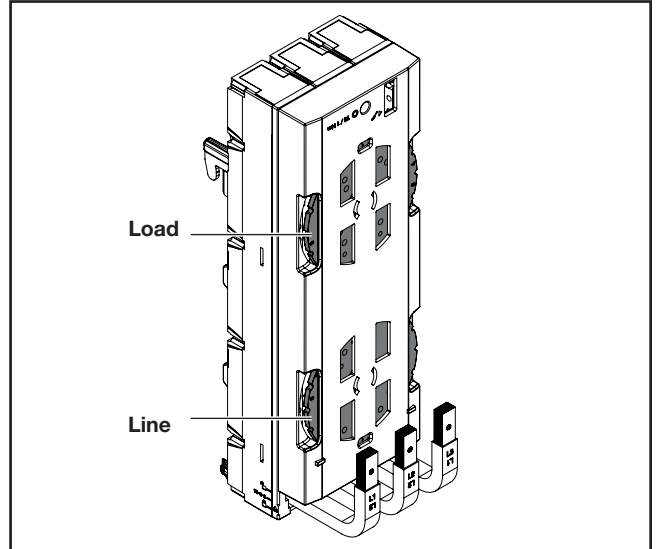
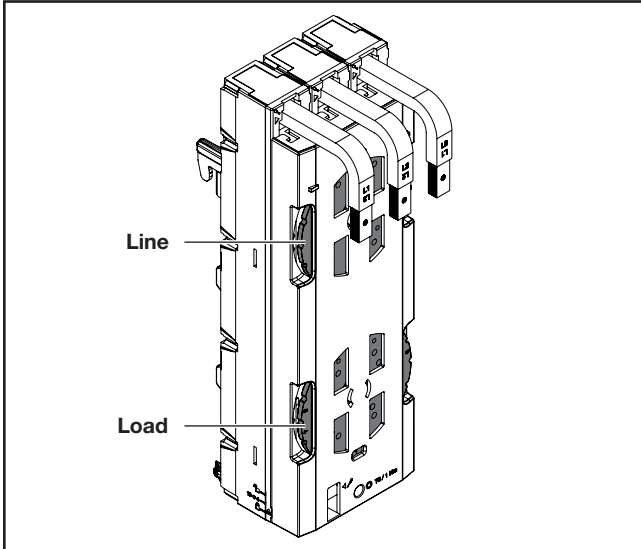

**Hinweis:** Details zur Einstellung des Easyfix: siehe Online-Berechnungssoftware „RiPower“, dem Konfigurator für Niederspannungsschaltanlagen bzw. Kapitel 6.3 „Schaltertabelle“.

**Note:** For details on the Easy-fix setting: see the online calculation software "RiPower", the configurator for low-voltage switchgear or chapter 6.3 "Table of switches".

**Remarque :** Détails sur le réglage du système Easy-fix : voir le configurateur pour les tableaux électriques basse tension « RiPower » ou le chapitre 6.3 « Tableau des disjoncteurs ».



RiPower

Art.-Nr. Model No. Référence	Einschraubtiefe min. mm Screw-in depth min. mm Longueur d'implantation min. mm	Einschraubtiefe max. mm Screw-in depth max. mm Longueur d'implantation max. mm
9360.500 9360.503 9360.600 9360.603	7	12
9360.512 9360.513 9360.612 9360.613	7	16
9360.525 9360.625 9360.535 9360.635	13	17

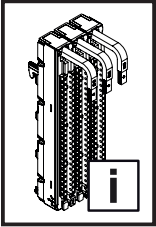

6. Hinweise zur Gerätemontage auf Easy-fix/Universal-fix  
 6. Notes on device installation on Easy-fix/Universal-fix  
 6. Remarques sur l'installation des appareils sur les systèmes Easy-fix/Universal-fix

- 6.2 Universal-fix
- 6.2 Universal-fix
- 6.2 Système Universal-fix

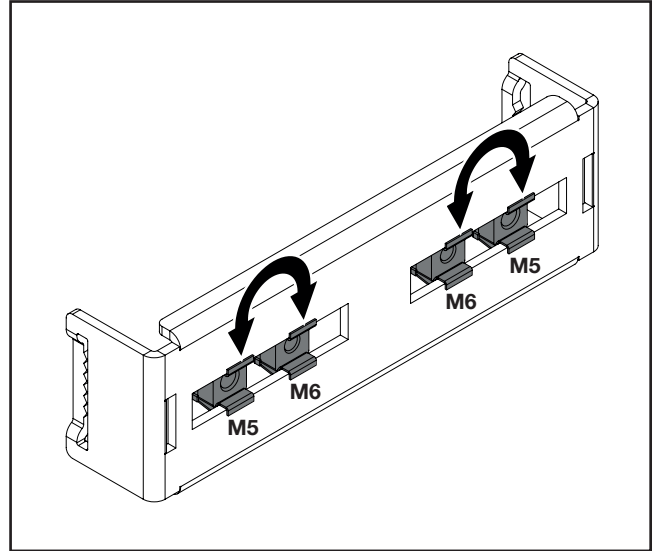
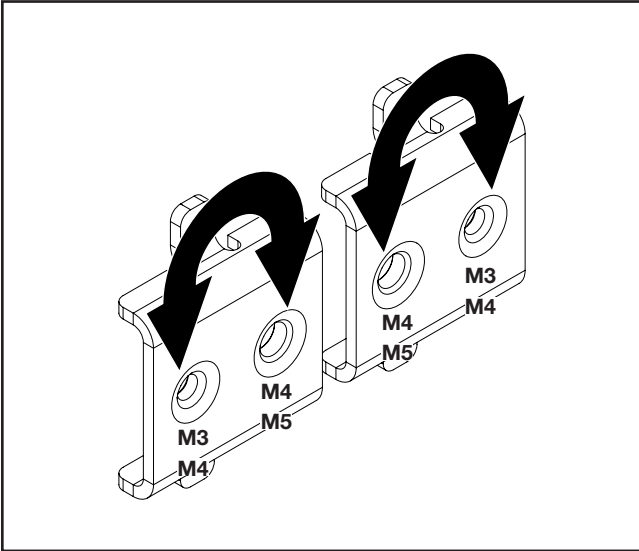

**i Hinweis:**  
 Details zur Auswahl des Easy-fix/Universal-fix: siehe Online-Berechnungssoftware „RiPower“, dem Konfigurator für Niederspannungsschaltanlagen bzw. Kapitel 6.3 „Schaltertabelle“.  
 Einschraubtiefe gemäß Tabelle beachten!

**Note:**  
 For details on the Easy-fix/Universal-fix selection: see the online calculation software "RiPower", the configurator for low-voltage switchgear or chapter 6.3 "Table of switches".  
 Observe the screw-in depth according to the table!

**Remarque :**  
 Détails sur la sélection du système Easy-fix / Universal-fix : voir le configurateur pour les tableaux électriques basse tension « RiPower » ou le chapitre 6.3 « Tableau des disjoncteurs ».  
 Respecter la profondeur de vissage selon le tableau !



Art.-Nr. Model No. Référence	Einschraubtiefe min. mm Screw-in depth min. mm Longueur d'implantation min. mm	Einschraubtiefe max. mm Screw-in depth max. mm Longueur d'implantation max. mm
9360.500 9360.503 9360.600 9360.603	7	12
9360.512 9360.513 9360.612 9360.613	7	16
9360.525 9360.625 9360.535 9360.635	13	17

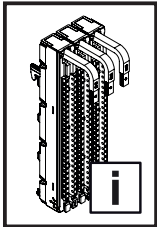

**6. Hinweise zur Gerätemontage auf Easy-fix/Universal-fix**  
**6. Notes on device installation on Easy-fix/Universal-fix**  
**6. Remarques sur l'installation des appareils sur les systèmes Easy-fix/Universal-fix**

**6.3 Schaltertabelle**  
**6.3 Table of switches**  
**6.3 Tableau des disjoncteurs**

CB 160 A (9360.500 + 9360.600)					
Hersteller Manufacturer Fabricant	Baureihe Series Gamme	Typ Model Type	Bemessungsstrom Rated current Courant nominal	Line	Load
ABB	Tmax XT	XT1	160 A	4	1
ABB	Tmax XT	XT2	160 A	5	3
Siemens	3VA1	3VA10	100 A	7	6
Siemens	3VA1	3VA11	160 A	7	6
Siemens	3VA5	3VA51	125 A	1	1
Schneider Electric	EasyPact	EZC	100 A	3	4
Schneider Electric	ComPacT	NSXm	160 A	2	2
Rockwell	140G	Frame Size G	100 A	4	1
Rockwell	140G	Frame Size H	100 A	5	3
Rockwell	140G	Frame Size G	125 A	4	1
Rockwell	140G	Frame Size H	125 A	5	3
Rockwell	140G	Frame Size G	160 A	4	1
Rockwell	140G	Frame Size H	160 A	5	3

CB 250 A (9360.512 + 9360.612)					
Hersteller Manufacturer Fabricant	Baureihe Series Gamme	Typ Model Type	Bemessungsstrom Rated current Courant nominal	Line	Load
ABB	Tmax XT	XT3	250 A	1	4
ABB	Tmax XT	XT4	250 A	6	4
Siemens	3VA2	3VA20	100 A	6	4
Siemens	3VA2	3VA21	160 A	6	4
Siemens	3VA2	3VA22	250 A	6	4
Schneider Electric	ComPacT	NSX100	100 A	5	3
Schneider Electric	ComPacT	NSX160	160 A	5	3
Schneider Electric	TeSys	GV5	220 A	5	1
Schneider Electric	EasyPact	EZC	250 A	3	2
Schneider Electric	ComPacT	NSX250	250 A	5	3
Rockwell	140G	Frame Size I	225 A	1	4
Rockwell	140G	Frame Size J	250 A	6	4
Mitsubishi	NF	NF160-SGV	160 A	2	2
Mitsubishi	NF	NF250-	250 A	2	2

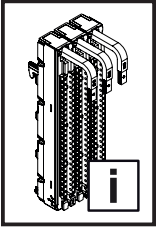

**6. Hinweise zur Gerätemontage auf Easy-fix/Universal-fix**  
**6. Notes on device installation on Easy-fix/Universal-fix**  
**6. Remarques sur l'installation des appareils sur les systèmes Easy-fix/Universal-fix**

**6.3 Schaltertabelle**  
**6.3 Table of switches**  
**6.3 Tableau des disjoncteurs**

CB 400 A (9360.525 + 9360.625) / CB 630 A (9360.535 + 9360.635)					
Hersteller Manufacturer Fabricant	Baureihe Series Gamme	Typ Model Type	Bemessungsstrom Rated current Courant nominal	Line	Load
ABB	Sace Isomax	S5 400	400 A	1	1
ABB	Sace Isomax	S5	630 A	1	1
ABB	Tmax	T5	400 A	3	3
ABB	Tmax	T5	630 A	3	3
ABB	Tmax XT	XT5	400 A	3	3
ABB	Tmax XT	XT5	630 A	3	3
Chint	NM8N	NM8N-400	400 A	1	1
Chint	NM8N	NM8N-630	630 A	1	1
Chint	NXM	NXM-400S	400 A	6	6
Chint	NXM	NXM-630S	630 A	6	6
Chint	NXMS	NXMS-400	400 A	6	6
Chint	NXMS	NXMS-630	630 A	6	6
Eaton	NZM	NZM3	400 A	8	8
Eaton	NZM	NZM3	630 A	8	8
Fuji Electric	BW	BW400_-3P	400 A	6	6
Hager	X630	X630	630 A	3	3
Hyundai Electric	HGM	400AF	400 A	6	6
Hyundai Electric	HGP	400	400 A	5	5
Hyundai Electric	HGP	630AF	630 A	5	5
LS Electric	Metasol	400AF	400 A	6	6
LS Electric	Susol	TS400	400 A	5	5
LS Electric	Susol	TS630	630 A	5	5
Mitsubishi	NF	NF400-SW	400 A	6	6
Mitsubishi	NF	NF630-SW	630 A	6	6
OEZ	BH	BH630	630 A	7	7
Rockwell	140G	140G-K0F3-D40	400 A	3	3
Rockwell	140G	140G-M0F3-D63	630 A	3	3
Schneider Electric	ComPact	NSX400	400 A	2	2
Schneider Electric	ComPact	NSX630	630 A	2	2
Schrack	Brand Eaton NZM3	MC3	630 A	8	8
Siemens	3VA2	3VA23	400 A	1	1
Siemens	3VA2	3VA24	630 A	1	1
Terasaki	Tembreak2	S400	400 A	3	3
Terasaki	Tembreak2	E630, S630	630 A	3	3

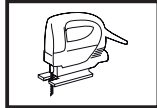
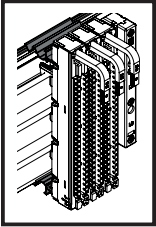

DE EN FR



- 7. Anwendung mit RiLine60
- 7. Application with RiLine60
- 7. Utilisation avec RiLine60

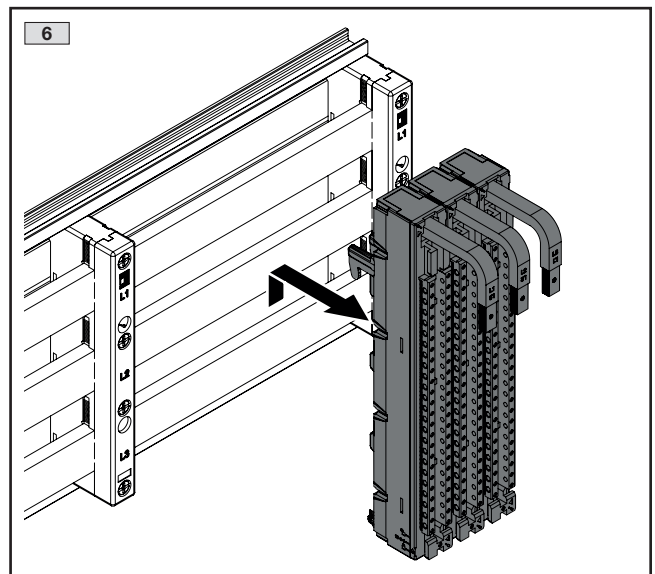
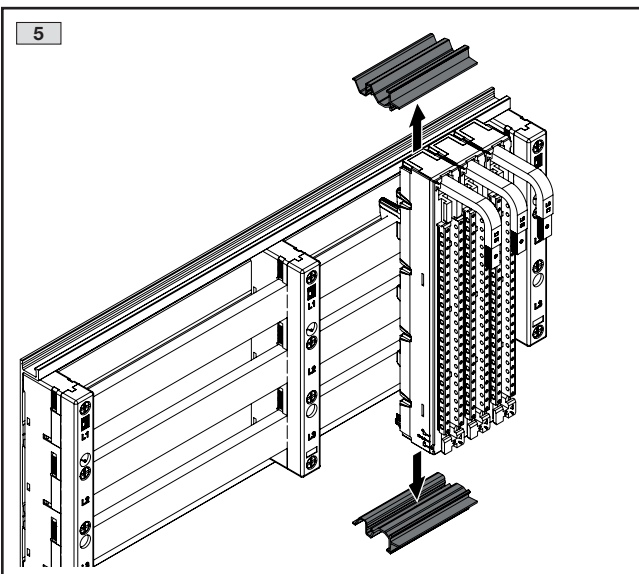
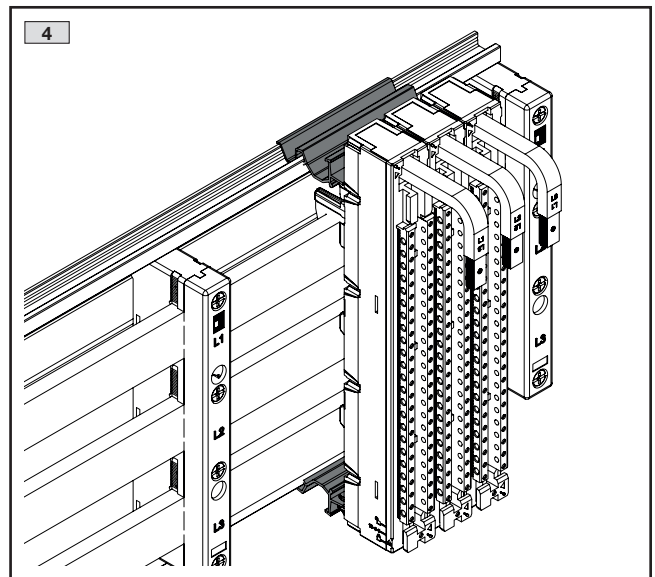
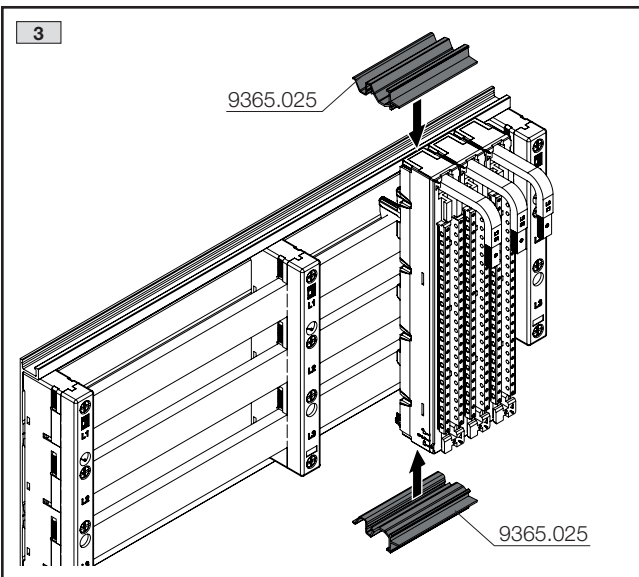
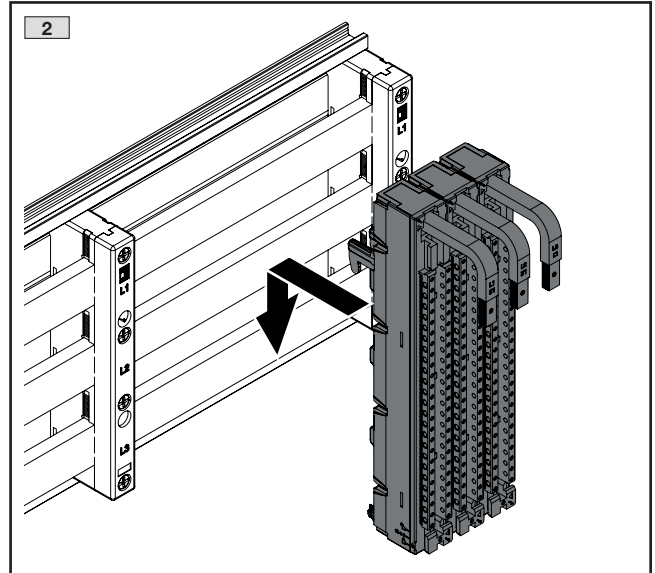
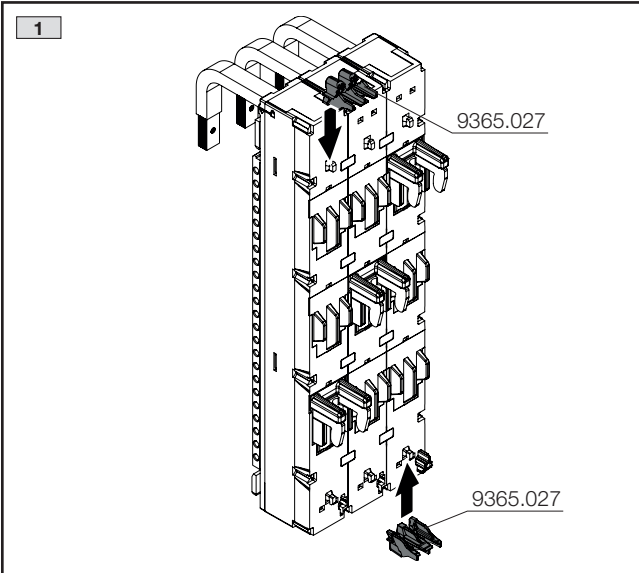

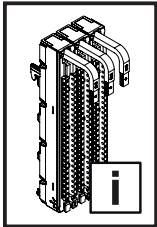

**8. Technische Daten**  
**8. Technical specifications**  
**8. Caractéristiques techniques**

Art.-Nr. Model No. Référence	Einheit Unit Unité	9360.500 9360.600	9360.503 9360.603	9360.512 <sup>1)</sup> 9360.612 <sup>1)</sup>	9360.513 <sup>1)</sup> 9360.613 <sup>1)</sup>
Bemessungsstrom max. Max. rated current Courant nominal max.	A	160		250	
Breite Width Largeur	mm	82		109	
Höhe Height Hauteur	mm	252			
Tiefe Depth Profondeur	mm	63			
Leitungsabgang Cable outlet Départ de ligne		unten bottom par le bas	oben top par le haut	unten bottom par le bas	oben top par le haut
Polzahl Number of poles Nombre de pôles		3			
Sammelschienenstärke Busbar thickness Épaisseur des barres de courant	mm	5/10			
Schienenmittenabstand Bar centre distance Entraxe de barres	mm	60			
Umgebungstemperatur (Betrieb) Ambient temperature (operation) Température ambiante (de fonctionnement)	°C	-5 ... +55 (IEC) -5 ... +55 (CEI) 0 ... +40 (UL)			
Umgebungsfeuchte relativ (Betrieb) Relative ambient humidity (operation) Taux d'humidité ambiante relative (de fonctionnement)	%	10 ... 90			
<b>Angaben IEC 61439-1/-2</b> <b>IEC 61439-1/-2 details</b> <b>Données CEI 61439-1/-2</b>					
Bemessungsbetriebsspannung max. Max. rated operating voltage. Tension de régime nominale max.	VAC	690			
Bemessungsstoßspannungsfestigkeit Rated impulse withstand voltage Tension de tenue aux chocs	kV	8			
Bemessungsbetriebsspannung max. Max. rated operating voltage. Tension de régime nominale max.	VDC	690			
Bemessungsisolationsspannung Ui Rated insulation voltage Ui Tension d'isolation nominale Ui	V	1000			
<b>Angaben UL 508</b> <b>UL 508 details</b> <b>Données UL 508</b>					
Bemessungsbetriebsspannung max. Max. rated operating voltage. Tension de régime nominale max..	VAC	600			
Bemessungsstrom Rated current Courant nominal	A	125		210	
SCCR ungeschützt SCCR unprotected Courant de court-circuit (SCCR) non protégé	kA	10 (600 V)			

<sup>1)</sup> Bei Anwendung im Dauerbetrieb (100 % ED) ist zusätzlich zum Bemessungsbelastungsfaktor (IEC 61439-1 und -2, Tabelle 101) ein Reduktionsfaktor von 0,85 anzuwenden.  
 When used in continuous operation (100% duty cycle), a reduction factor of 0.85 must be applied in addition to the rated diversity factor (IEC 61439-1 and -2, Table 101).  
 En cas d'utilisation en service continu (durée de fonctionnement de 100 %), un facteur de réduction de 0,85 doit être appliqué en plus du facteur de charge assigné (CEI 61439-1 et -2, tableau 101).

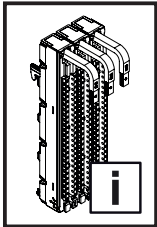

**8. Technische Daten**  
**8. Technical specifications**  
**8. Caractéristiques techniques**

Art.-Nr. Model No. Référence	Einheit Unit Unité	9360.525 9360.625	9360.535 <sup>1)</sup> 9360.635 <sup>1)</sup>
Bemessungsstrom max. Max. rated current Courant nominal max.	A	400	630
Breite Width Largeur	mm	145	
Höhe Height Hauteur	mm	325	
Tiefe Depth Profondeur	mm	76	
Polzahl Number of poles Nombre de pôles		3	
Sammelschienenstärke t Busbar thickness t Épaisseur des barres de courant t	mm	5/10	
Schienenmittenabstand Bar centre distance Entraxe de barres	mm	60	
Umgebungstemperatur (Betrieb) Ambient temperature (operation) Température ambiante (de fonctionnement)	°C	-5 ... +55 (IEC) -5 ... +55 (CEI) 0 ... +40 (UL)	
Umgebungsfeuchte relativ (Betrieb) Relative ambient humidity (operation) Taux d'humidité ambiante relative (de fonctionnement)	%	10 ... 90	
<b>Angaben IEC 61439-1/-2</b> <b>IEC 61439-1/-2 details</b> <b>Données CEI 61439-1/-2</b>			
Bemessungsbetriebsspannung max. Max. rated operating voltage. Tension de régime nominale max.	VAC	690	
Bemessungsstoßspannungsfestigkeit Rated impulse withstand voltage Tension de tenue aux chocs	kV	8	
Bemessungsbetriebsspannung max. Max. rated operating voltage. Tension de régime nominale max.	VDC	690	
Bemessungsisolationsspannung U <sub>i</sub> Rated insulation voltage U <sub>i</sub> Tension d'isolation nominale U <sub>i</sub>	V	t= 5 mm: 800 t= 10 mm: 1000	
<b>Angaben UL 508</b> <b>UL 508 details</b> <b>Données UL 508</b>			
Bemessungsbetriebsspannung max. Max. rated operating voltage. Tension de régime nominale max..	VAC	600	
Bemessungsstrom Rated current Courant nominal	A	400	500
SCCR ungeschützt SCCR unprotected Courant de court-circuit (SCCR) non protégé	kA	25 (600 V)	25 (600 V)

<sup>1)</sup> Bei Anwendung im Dauerbetrieb (100 % ED) ist zusätzlich zum Bemessungsbelastungsfaktor (IEC 61439-1 und -2, Tabelle 101) ein Reduktionsfaktor von 0,85 anzuwenden.  
 When used in continuous operation (100% duty cycle), a reduction factor of 0.85 must be applied in addition to the rated diversity factor (IEC 61439-1 and -2, Table 101).  
 En cas d'utilisation en service continu (durée de fonctionnement de 100 %), un facteur de réduction de 0,85 doit être appliqué en plus du facteur de charge assigné (CEI 61439-1 et -2, tableau 101).

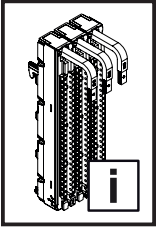

**8. Technische Daten**  
**8. Technical specifications**  
**8. Caractéristiques techniques**

Best.-Nr. Model No. Référence	SCCR geschützt	SCCR protected	Courant de court-circuit (SCCR) protégé
9360.500 9360.503 9360.600 9360.603	65 kA mit DIVQ/7 Leistungsschalter 125 A / 480 VAC 25 kA mit DIVQ/7 Leistungsschalter 125 A / 600 VAC	65 kA with DIVQ/7 circuit breaker 125 A / 480 VAC 25 kA with DIVQ/7 circuit breaker 125 A / 600 VAC	65 kA avec un disjoncteur DIVQ/7 125 A / 480 VAC 25 kA avec un disjoncteur DIVQ/7 125 A / 600 VAC
9360.512 9360.513 9360.612 9360.613	65 kA mit DIVQ/7 Leistungsschalter 250 A / 480 VAC	65 kA with DIVQ/7 circuit breaker 250 A / 480 VAC	65 kA avec un disjoncteur DIVQ/7 250 A / 480 VAC
9360.525 9360.625 9360.535 9360.635	100 kA mit DIVQ/7 Leistungsschalter 600 A / 480 VAC 100 kA mit DIVQ/7 Leistungsschalter 600 A / 600 VAC	100 kA with DIVQ/7 circuit breaker 600 A / 480 VAC 100 kA with DIVQ/7 circuit breaker 600 A / 600 VAC	100 kA avec un disjoncteur DIVQ/7 600 A / 480 VAC 100 kA avec un disjoncteur DIVQ/7 600 A / 600 VAC



**Hinweis:**

Wenn nicht anders angegeben, gelten die Umgebungsbedingungen der IEC 61439 Teil 1 und Teil 2. Spezielle Anwendungen sind beim Hersteller zu erfragen.

**Note:**

Unless otherwise specified, the ambient conditions specified in IEC 61439 Part 1 and Part 2 apply. Please consult the manufacturer for special applications.

**Remarque :**

Sauf indication contraire, les conditions ambiantes de la norme CEI 61439, parties 1 et 2, s'appliquent. Pour les applications spéciales, veuillez consulter le fabricant.

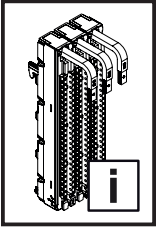

**9. Lagerung**  
**9. Storage**  
**9. Stockage**

DE

Bei der Lagerung dieser Komponenten ist zu beachten, dass

- die Umgebungstemperatur nicht höher als +75 °C ist.
- die Umgebungstemperatur nicht niedriger als -25 °C ist.
- die relative Luftfeuchte zwischen 10 % und 95 %, nicht kondensierend, liegt.

EN

When storing these components, ensure that

- the ambient temperature is not higher than +75 °C.
- the ambient temperature is not lower than -25 °C.
- the relative humidity lies between 10% and 95% (non-condensing).

FR

Lors du stockage de ces composants, il faut veiller à ce que

- la température ambiante ne soit pas supérieure à +75 °C.
- la température ambiante ne soit pas inférieure à -25 °C.
- l'humidité relative de l'air se situe entre 10 % et 95 % (sans condensation).

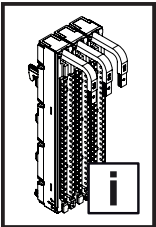

**10. Garantie**  
**10. Warranty**  
**10. Garantie**

DE

Es gelten die in den Verkaufs- und Lieferbedingungen der jeweiligen Rittal Vertriebs- und Tochtergesellschaften genannten Bedingungen.

EN

The conditions named in the sales and delivery conditions of the associated Rittal agents and subsidiaries apply.

FR

Les conditions générales de vente des représentations et filiales Rittal sont contractuelles.

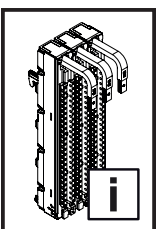

**11. Kundendienstadressen**  
**11. Customer services addresses**  
**11. Coordonnées des services après-vente**

DE

Kontaktdaten finden Sie auf der Internetseite von Rittal unter folgender Adresse:

- <https://www.rittal.de/Rittal-Standorte>

EN

Contact details can be found on the Rittal website at:

- <https://www.rittal.com/rittal-locations>

FR

Vous trouverez les coordonnées du service après-vente sur le site internet :

- <https://www.rittal.fr/sites-rittal>

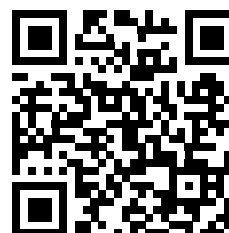
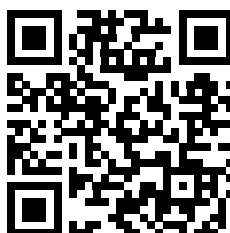
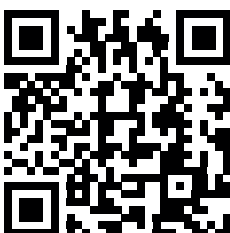

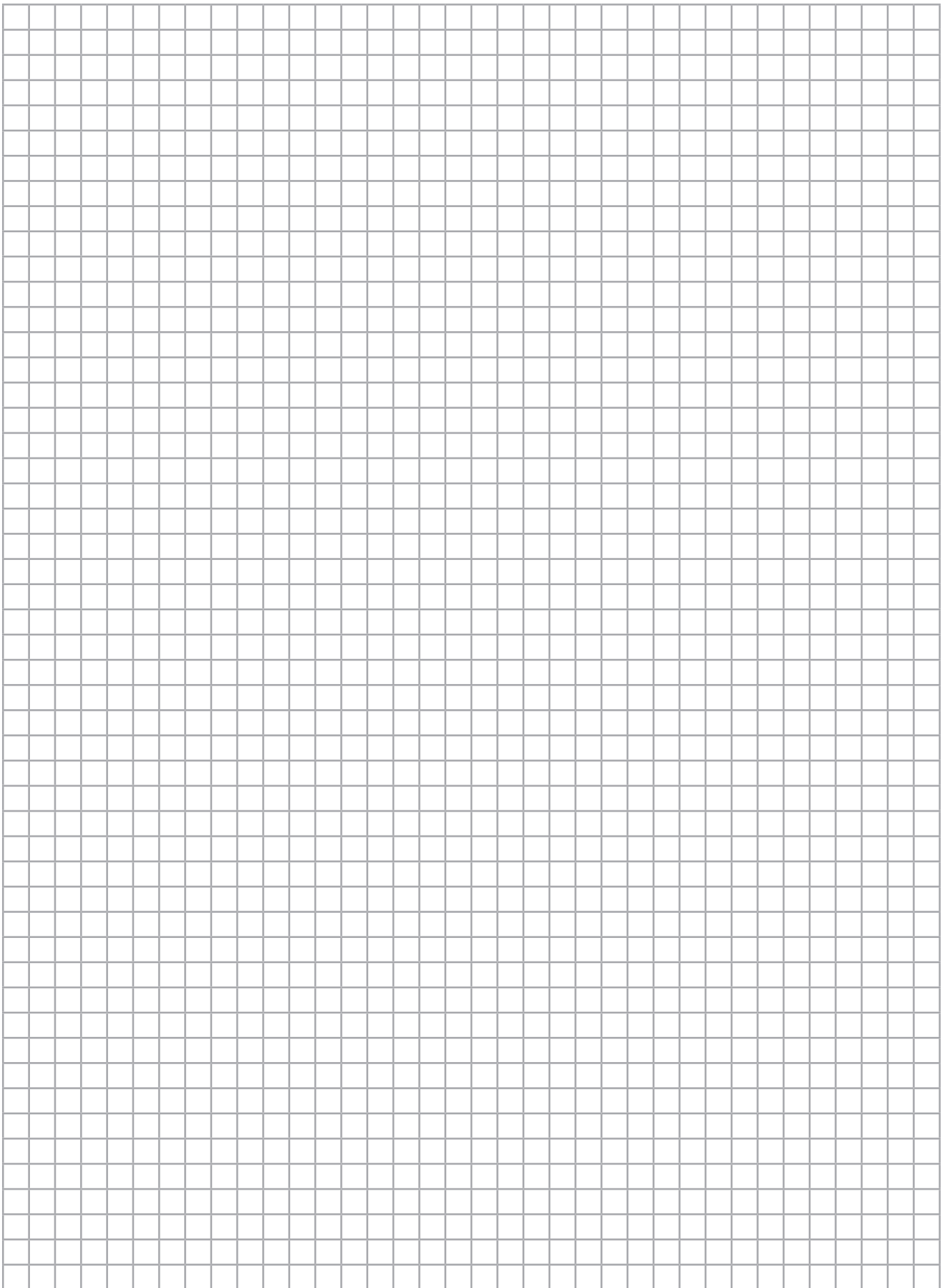

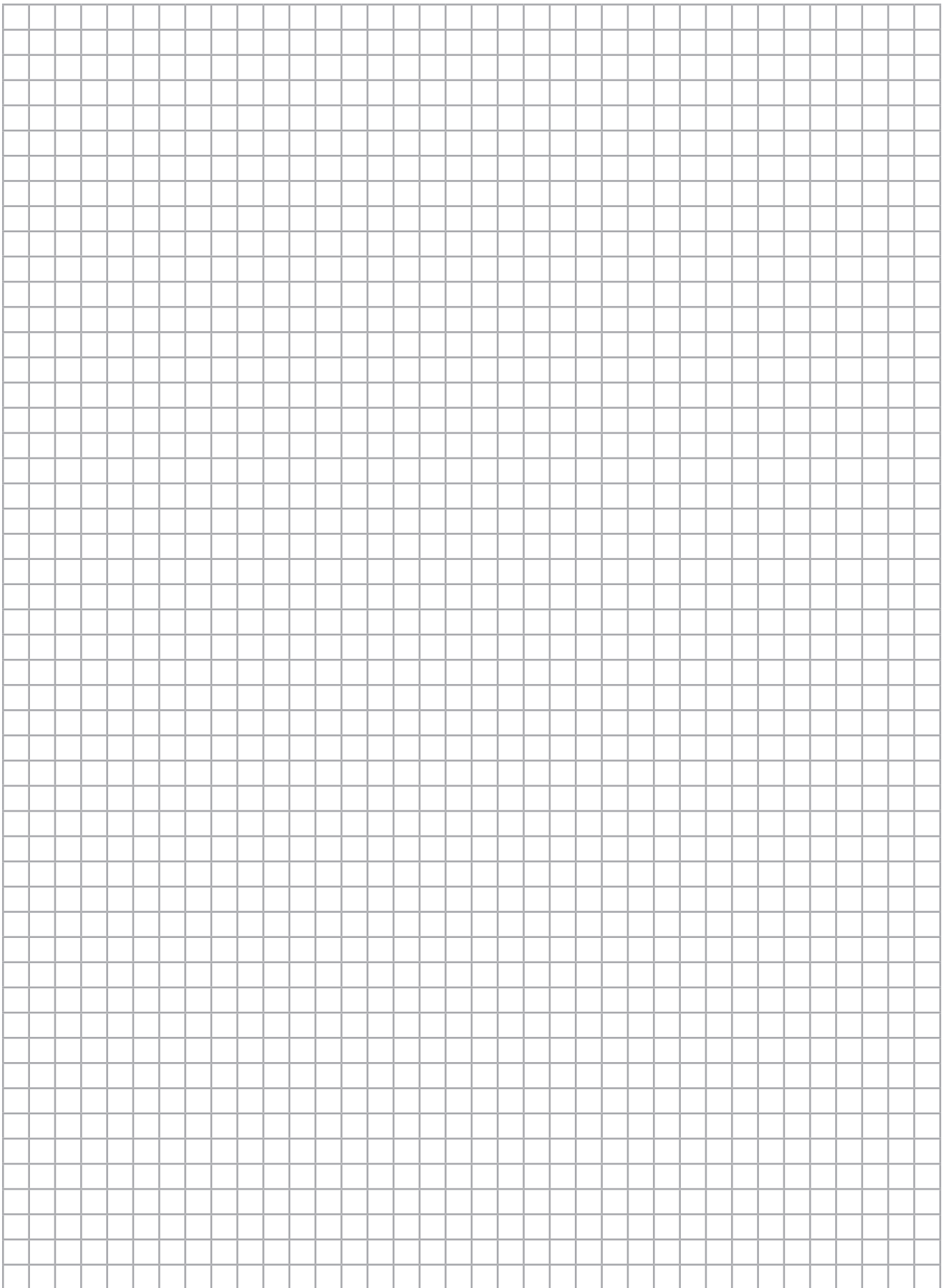

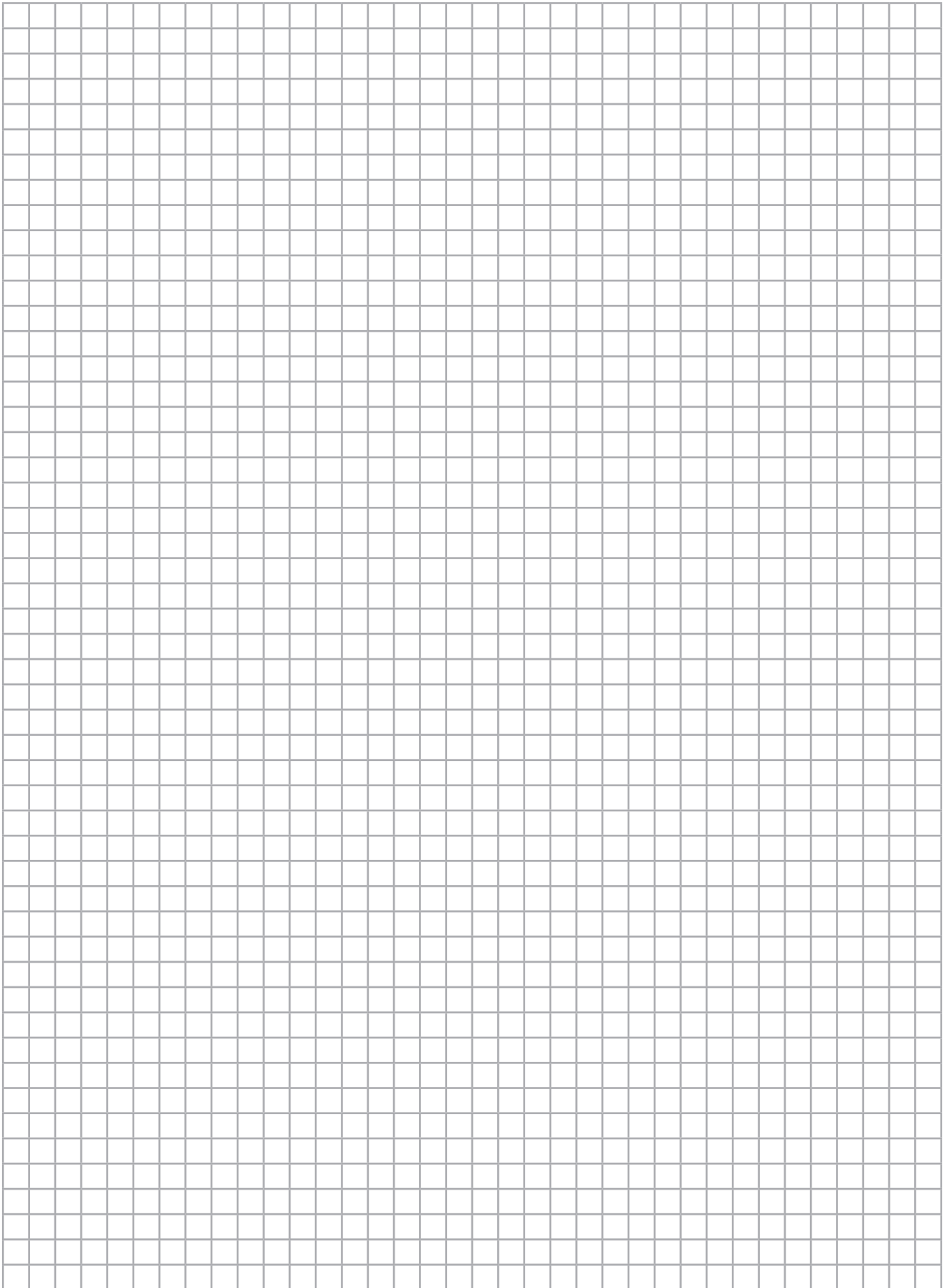

# Rittal – The System.

Faster – better – everywhere.

- Enclosures
- Power Distribution
- Climate Control
- IT Infrastructure
- Software & Services

You can find the contact details of all Rittal companies throughout the world here.



[www.rittal.com/contact](http://www.rittal.com/contact)

RITTAL GmbH & Co. KG  
Auf dem Stuetzelberg · 35745 Herborn · Germany  
Phone +49 2772 505-0  
E-mail: [info@rittal.de](mailto:info@rittal.de) · [www.rittal.com](http://www.rittal.com)

04.2026/D-0000-00004007-08

ENCLOSURES

POWER DISTRIBUTION

CLIMATE CONTROL

IT INFRASTRUCTURE

SOFTWARE & SERVICES



FRIEDHELM LOH GROUP