

Rittal – The System.

Faster – better – everywhere.

Enclosure cooling unit with refrigerant R-1234yf



SK 3485330
SK 3486330
SK 3487330
SK 3488340
SK 3489340

Assembly and operating instructions

ENCLOSURES

POWER DISTRIBUTION

CLIMATE CONTROL

IT INFRASTRUCTURE

SOFTWARE & SERVICES

FRIEDHELM LOH GROUP



Preface

EN

Preface

Dear Customer!

Thank you for choosing a "Blue e+ Outdoor" enclosure cooling unit (referred to hereafter as "cooling unit") from Rittal.

Yours
Rittal GmbH & Co. KG

Rittal GmbH & Co. KG
Auf dem Stützelberg

35745 Herborn
Germany

Phone: +49(0)2772 505-0
Fax: +49(0)2772 505-2319

E-mail: info@rittal.com
www.rittal.com
www.rittal.de

We are always happy to answer any technical questions regarding our entire range of products.

Contents

1	Notes on documentation	4	7.2.2	Changing a parameter value	30
1.1	CE labelling	4	7.3	Information menu	30
1.2	Storing the documents	4	7.3.1	Temperature information	30
1.3	Symbols used in these operating instructions	4	7.3.2	Device information	30
1.4	Other applicable documents	4	7.3.3	Efficiency information	30
2	Safety instructions	5	7.4	Configuration menu	31
2.1	General safety instructions	5	7.4.1	Temperature	31
2.2	Safety instructions for transportation	5	7.4.2	Network	33
2.3	Safety instructions for assembly	5	7.4.3	Alarm relays	34
2.4	Safety instructions for installation	5	7.4.4	Language settings	34
2.5	Safety instructions for operation	6	7.4.5	Self-test	34
2.6	Safety instructions for maintenance	6	7.5	System messages	34
2.7	Operating and technical staff	6	7.5.1	Occurrence of a malfunction	35
2.8	Other dangers when using the cooling unit	6	7.5.2	Display in case of errors	35
2.9	IT safety instructions	6	7.5.3	Parallel device control	35
2.9.1	Measures for products and systems	6	7.6	List of system messages	36
3	Product description	8	8	Inspection and maintenance	39
3.1	Functional description and components	8	8.1	Safety instructions for maintenance work	39
3.1.1	Function	8	8.2	Notes on the refrigerant circuit	39
3.1.2	Components	9	8.3	Maintenance work on the cooling unit	39
3.1.3	Control	9	8.4	Compressed air cleaning	39
3.1.4	Safety devices	9	8.4.1	Removing the cover	39
3.1.5	Condensation	9	8.4.2	Cleaning the components with compressed air	40
3.1.6	Door limit switch	9	8.4.3	Re-fitting the cover	40
3.2	Intended use, foreseeable misuse	10	9	Storage and disposal	41
3.3	Scope of supply	11	10	Technical specifications	42
4	Transport and handling	13	11	List of spare parts	45
4.1	Delivery	13	12	Drawings	46
4.2	Unpacking	13	12.1	Mounting cut-outs on single-walled enclosure panels without a mounting frame	46
4.3	Transport	13	12.2	Mounting on single- and twin-walled enclosure panels with a mounting frame	47
5	Installation	15	12.2.1	SK 3485330	47
5.1	Safety instructions	15	12.2.2	SK 3486330, SK 3487330, SK 3488340, SK 3489340	48
5.2	Siting location requirements	15	12.3	Dimensions and installation depths	49
5.3	Assembly procedure	16	12.3.1	External mounting, partial internal mounting and full internal mounting (SK 3485330)	49
5.3.1	Assembly instructions	16	12.3.2	External mounting, partial internal mounting and full internal mounting (SK 3486330 and SK 3487330)	50
5.3.2	Mounting options	17	12.3.3	External mounting, partial internal mounting and full internal mounting (SK 3488340 and SK 3489340)	51
5.3.3	Make a mounting cut-out in the enclosure	18	13	Accessories	52
5.3.4	Fitting the cooling unit without a mounting frame	18	14	Customer service addresses	53
5.3.5	Fitting the cooling unit with a mounting frame	20	15	Compact service information	54
5.3.6	Connect the condensate water discharge (optional)	22			
5.4	Electrical connection	23			
5.4.1	Notes on electrical installation	23			
5.4.2	Install the power supply	26			
5.4.3	Connect the alarm relays	27			
5.4.4	Interfaces	27			
6	Commissioning	28			
7	Operation	29			
7.1	General	29			
7.2	Layout of the display	29			
7.2.1	Start screen	29			

1 Notes on documentation

1.1 CE labelling

Rittal GmbH & Co. KG confirms the conformity of the cooling unit with the European Union's Machinery Directive 2006/42/EC and EMC Directive 2014/30/EU. A simplified declaration of conformity can be found in the assembly and installation instructions enclosed with the device (see also the Rittal website). These are the original operating instructions.

The built-in passive NFC functionality operates at 13.56 MHz (HF). The reflected field strength depends on the active reader unit. The interface is designed for operation with reader units compliant with EN 300330 (HF).



1.2 Storing the documents

The assembly and operating instructions as well as all other applicable documents are an integral part of the product. They must be issued to everyone who works with the unit and must always be available and on hand for operating and maintenance personnel.

1.3 Symbols used in these operating instructions

The following symbols are used in this documentation:



Warning!

Hazardous situation which may lead to death or serious injury if the instructions are not followed.



Caution!

Hazardous situation which may lead to (minor) injuries if the instructions are not followed.



Note:

Indicates situations that can lead to material damage.

- This symbol indicates an "action point" and shows that you should perform an operation or procedure.

1.4 Other applicable documents

Assembly and operating instructions exist as paper documents for the unit types described here and are enclosed with the equipment.

We cannot accept any liability for damage associated with failure to observe these instructions.

- Please also observe the instructions for any accessories used.

2 Safety instructions

2.1 General safety instructions

Please observe the following general safety instructions for the installation and operation of the system:

- Always wear the required personal safety equipment when working on this device. As a bare minimum, this should comprise ear defenders, safety shoes and protective gloves.
- Before removing the hood, allow the unit to cool for at least 10 minutes to eliminate the risk of burns from hot surfaces.
- Please do not make any changes to the cooling unit that are not described in these operating instructions or other applicable assembly and operating instructions.
- Note that refrigerants are odourless. In particular, in case refrigerant is unintentionally released, please keep the workplace well-ventilated to avoid inhaling large quantities of refrigerant.
- To avoid damaging the pipes or heat exchanger, do not use sharp objects when working on the unit.
- The unit must not be drilled or burnt.
- The accumulation of flammable substances inside the unit must be avoided.
- All persons working on the refrigerant circuit must have a certificate of competence from an industry-accredited body that demonstrates their competence in the safe handling of refrigerants using an accepted industry procedure. The work must be performed in accordance with Rittal specifications.
- Only objects approved by Rittal may be used to accelerate the defrosting process.
- When the unit is decommissioned, it must be labelled with the decommissioning date together with a note stating it is filled with flammable refrigerant.
- At ambient temperatures above 30 °C/86 °F, the surface temperatures of the cooling unit may exceed the threshold temperatures for 1st and 2nd degree burns with contact times ≤ 1 second.
- At ambient temperatures below -7 °C/19.4 °F, the surface temperatures of the cooling unit may drop below the threshold values for frostbite with contact times of ≤ 10 seconds.
- Please refer to the additional information provided in the document "Supplement to the assembly, installation and operating instructions for devices containing flammable refrigerants to UL 60335-2-40 Annex DD" available on the Rittal website.



- Sticker on the packaging: Flammable, warning of flammable materials



- Sticker near the rating plate: Low flammability (A2L), warning of flammable materials



- Other than these general safety instructions, it is also vital to observe the specific safety instructions when carrying out the tasks described in the following chapters.

2.2 Safety instructions for transportation

- The unit may only be shipped as a package.
- Keep the unit aligned with the markings on the packaging throughout transport.
- Use a sufficiently large pallet to prevent it tipping over.
- Please observe the maximum permissible weight to be lifted by one person. Use suitable lifting devices, if needed.
- Shipping braces (such as a structure made from square timbers or boards) must be used when transporting cooling units already mounted on the enclosure. These braces support the cooling unit and prevent it from slipping in case of impact.
- If the cooling unit has been mounted on a door, close the door and keep it closed during transportation.

2.3 Safety instructions for assembly

- Ensure that the cooling unit is only installed in a dry condition and in a dry environment.
- To achieve a secure seal against water ingress from outside, the gasket included in the scope of supply must be fitted to seal the interface between the cooling unit and the enclosure in accordance with these instructions.
- When assembling the cooling unit, if possible, position it so no accidental contact can occur during operation.
- All ventilation openings of the cooling unit must be freely accessible after assembly and must not be blocked.
- During assembly, the cooling unit is at risk of dropping through the mounting cut-out.
- Do not assemble and re-activate the device until it is completely dry.
- When dismantling, there is a risk that the unit could slip and fall. Ensure a secure grip, particularly with contaminated units.

2.4 Safety instructions for installation

- Please be sure to observe the applicable regulations governing electrical installations of the country in

which the device is installed and operated as well as national regulations for accident prevention. Please also observe any internal company regulations, such as work, operating and safety regulations.

- The connection regulations of the appropriate power supply company are to be followed. Otherwise, there is risk of injury from electric shock if the connection to the unit is defective or connected incorrectly in any way.
- Do not strip too much insulation from the connection cable, otherwise the admissible clearance/creepage distances from the terminal point may not be met.
- The cooling unit must be connected to the mains via an all-pole disconnect to overvoltage category III (IEC 61058-1).
- The drill holes on the unit rear may be used only for assembling the IoT interface with the screws supplied with this unit. If longer screws are used, there is a risk of undershooting the clearance and creepage distances or electric shock.

2.5 Safety instructions for operation

- The operational safety of the cooling unit is only warranted if used as intended. The technical specifications and limit values stated must not be exceeded under any circumstances. In particular, this applies to the specified ambient temperature range and IP protection category.
- The products should only be combined and operated with the prescribed Rittal system accessories.
- Operating the cooling unit in direct contact with water, aggressive materials or inflammable gases and vapours is prohibited.

2.6 Safety instructions for maintenance

- The device must only be cleaned by trained specialists. De-energise the device prior to cleaning.
- Never use flammable liquids for cleaning.
- If assistance of other persons is required for maintenance and repair work, a person trained in handling flammable refrigerants should supervise the work at all times.

2.7 Operating and technical staff

- The assembly, installation, commissioning, maintenance and repair of this cooling unit may only be performed by qualified, trained personnel.
- Only properly instructed personnel may operate a cooling unit with the system operational.
- Children and persons with limited cognitive/coordinate abilities must **not** operate, maintain or clean the unit or be allowed to use it as a toy.

2.8 Other dangers when using the cooling unit

When installing the cooling unit (see section 5 "Installation"), there is a risk that the enclosure could become unbalanced and tip over.

- In such cases, the enclosure should be bolted to the floor as a precaution.

There is also a risk of the cooling unit tipping over after the mounting frame has been fitted onto the cooling unit. The cooling unit is only stable whilst the mounting frame is not fitted.

- It is therefore particularly important to brace the unit and prevent it from becoming unbalanced once the mounting frame has been installed.
- If the air inlet or outlet of the cooling unit is obstructed, there is a risk of air short-circuits, resulting in inadequate climate control.
- Please ensure that the electronic assemblies in the enclosure are installed in accordance with section 5.3.1 "Assembly instructions".
 - Where applicable, use suitable components to divert the air.
 - Please observe the prescribed minimum distances at the installation site as outlined in section 5.3.1 "Assembly instructions".

2.9 IT safety instructions

To ensure the availability, confidentiality and integrity of data, products, networks and systems must be protected against unauthorised access.

Such protection can be achieved only with organisational and technical measures. To satisfy the increased safety requirements, Rittal recommends the observance of the following measures. Furthermore, more detailed information can be found on the websites of Bundesamt für Sicherheit in der Informationstechnik (Federal Office for IT Security – BSI).

2.9.1 Measures for products and systems

Embed products and systems not in public networks.

- Make sure that the system is only operated in protected networks.

Configure the firewall

- To protect your networks, and the embedded products and systems against external effects, configure a firewall.
- Also deploy a firewall for segmentation of a network or to isolate a controller.

Consider defence-in-depth mechanisms during the planning phase

- Consider defence-in-depth mechanisms for your system planning.
- Defence-in-depth mechanisms cover several levels of mutually coordinated security measures.

Restrict access authorisations

- Restrict access authorisations to networks and systems to only persons that need an authorisation.

Protect accesses

- Do not use the default passwords; instead, use secure, long passwords containing numbers, a mix of upper case and lower case letters, symbols and no repetitions.
- Create random passwords with a password manager.

Deploy the current firmware version

- Ensure that the current Rittal firmware is deployed on all devices.
- The firmware can be downloaded from the associated product pages in the Internet.
- Observe the associated Release Notes for new firmware versions.

Deploy current security software

- To identify and eliminate security threats, such as viruses, trojans and other malicious software, security software should be installed on all PCs and kept up-to-date.
- Deploy whitelist tools to monitor the device context.
- Deploy an intrusion-detection system to validate the communication of your system.

Perform regular threat analyses

- Rittal recommends that you perform regular threat analyses.
- The threat analyses allow you to determine whether your adopted measures are effective.

Protect USB ports against access

- USB ports must be protected against physical access. Ensure that no unauthorised persons have access to USB ports.
- Sensitive data can be read for an unauthorised access to USB ports.

3 Product description

EN

3 Product description

3.1 Functional description and components

3.1.1 Function

There are two separate cooling circuits installed in the cooling unit.

- One conventional refrigerant circuit (compression system), and
- One heat pipe integrated into the condenser and evaporator coil.

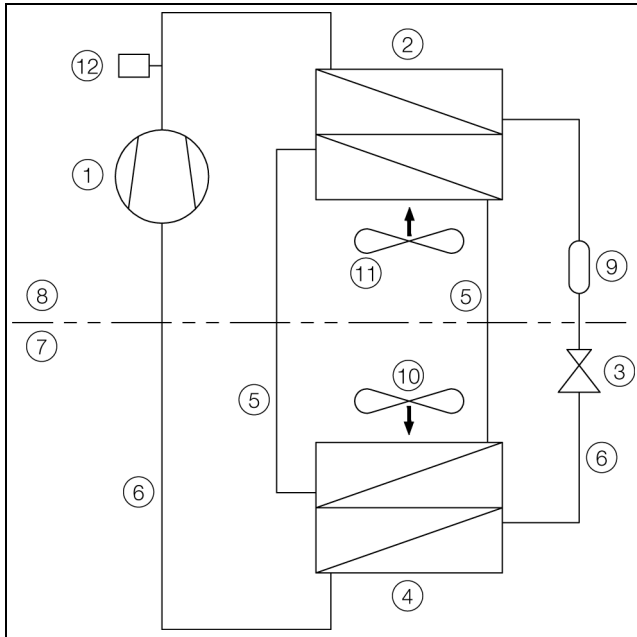

Fig. 1: Cooling circuit

Key

- 1 Compressor
- 2 Condenser (dual version)
- 3 Expansion valve
- 4 Evaporator coil (dual version)
- 5 Refrigerant circuit with heat pipe
- 6 Refrigerant circuit with compression system
- 7 Internal circuit
- 8 External circuit
- 9 Dryer/collector
- 10 Internal fan
- 11 External fan
- 12 PSA^H pressure monitor

In both cooling circuits, the individual components are connected with pipes in which the refrigerant is circulating. This refrigerant is very environmentally friendly, thanks to the following properties:

- Chlorine-free
- Does not deplete the ozone layer (ozone destruction potential ODP = 0)

Refrigerant circuit with compression system

The refrigerant circuit with compression system is comprised of the following four main components:

1. Evaporator coil
2. Compressor
3. Condenser
4. Expansion valve

The evaporator coil fan draws hot air from the enclosure in the internal circuit of the cooling unit and passes it over the evaporator coil. After the evaporator coil, the cooled air is fed back into the enclosure via the outlet opening.

The air is cooled down by evaporating the refrigerant in the evaporator coil. The refrigerant vapour is transported by the compressor in the external circuit of the cooling unit to the condenser. There, the refrigerant condenses and becomes a liquid. The heat produced is dissipated by the condenser fan. The downstream electronic expansion valve reduces the high pressure of the refrigerant, and the refrigerant is then fed back into the evaporator coil.

Both the compressor and the two fans in the cooling unit are activated via an inverter. This makes it possible to control these components, so that the fan and compressor may be activated for a longer time but at a lower output and improved efficiency.

Refrigerant circuit with heat pipe

The additional second refrigerant circuit operates without a compressor, expansion valve or other control elements, and is integrated into the evaporator coil and condenser as a heat pipe.

The refrigerant inside the heat pipe absorbs thermal energy from the intake of enclosure air and evaporates. The gaseous refrigerant then rises through the pipeline until it reaches the condenser. The refrigerant is cooled down again in the condenser (provided $T_u < T_i$), and the heat released is emitted into the environment. Gravity then causes the liquid refrigerant to flow back down the pipelines. The whole cycle begins again.

3.1.2 Components

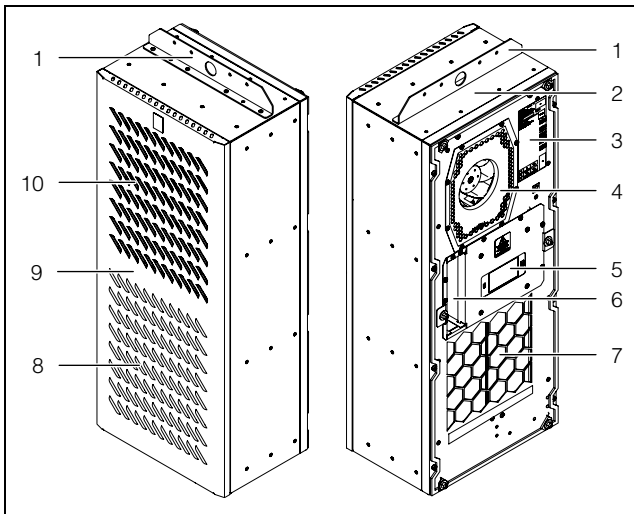

Fig. 2: Main components of cooling unit (SK 3485330)

Key

- | | |
|----|---------------------------------------|
| 1 | Crane bracket |
| 2 | Housing |
| 3 | Rating plate |
| 4 | Air inlet, inside |
| 5 | Display |
| 6 | Electrical connections and interfaces |
| 7 | Air outlet, inside |
| 8 | Air inlet, outside |
| 9 | Cover |
| 10 | Air outlet, outside |



Note:

Illustration shows unit SK 3485330 as an example.

3.1.3 Control

Rittal enclosure cooling units are fitted with a controller for setting the functions of the cooling unit.

Operation using this controller is described in section 7 "Operation".

3.1.4 Safety devices

- In the refrigerant circuit, the cooling units have a type-tested pressure monitor (to EN 12263) which switches off the cooling unit if the maximum admissible pressure is exceeded. Once the pressure drops back below the admissible pressure, the unit will automatically resume operation.
- Temperature monitoring prevents the evaporator coil from icing over. If there is a risk of icing, the compressor switches itself off and automatically switches itself back on again at higher temperatures.
- The compressor is monitored and protected by the inverter to prevent overloading.
- The fans have a built-in overload protection with automatic reset.
- In order to allow a reduction of pressure inside the compressor and hence a safe restart, once it has been

switched off (e.g. upon reaching the set temperature via the door limit switch function or via de-energising), the device will switch back on with a delay of 180 seconds.

- The device has floating contacts on the connection pins on terminals 1 and 3 of the signal connector (X2), via which system messages from the device may be polled, e.g. using a PLC.

3.1.5 Condensation

At high levels of humidity and low temperatures inside the enclosure, condensate water may form on the evaporator coil.

The cooling units have an automatic electrical condensate water evaporator. The thermal component used for this purpose is based on self-regulating PTC technology. Condensate water arising on the evaporator coil is collected in a tank in the external circuit of the cooling unit, and partially evaporated via the airflow. When the water level rises, the water enters the PTC thermal component and is evaporated (through-flow heater principle). The water vapour streams out of the cooling unit with the airflow from the external fan.

The PTC thermal component is activated automatically when the compressor is running, and continues to run for around 15 minutes after the compressor has been switched off. During the after-run phase, the condenser fan will likewise continue to run at low speed.

In the event of a short-circuit in the PTC component or if there is a risk of inverter overload (possible at high ambient temperatures), the PTC component will be deactivated. This means that any condensate water arising can be discharged via the safety overflow.

If the fuse has tripped, any condensate water is drained off via the safety overflow. The condensation is routed downwards out of the unit via a drain pipe on the evaporator coil divider panel. For this purpose, a hose may be connected to the condensate water nozzle (see section 5.3.6 "Connect the condensate water discharge (optional)").

3.1.6 Door limit switch

The cooling unit may be operated with a floating door limit switch connected. The door limit switch is available as accessory from Rittal (see section 13 "Accessories", page 52).

The door limit switch function causes the fans and the compressor in the cooling unit to gradually slow down and then switch off after approximately 15 seconds when the enclosure door is opened (contacts 5 and 6 closed). This prevents the formation of condensate water inside the enclosure while the enclosure door is open. In order to prevent damage to the unit, it is equipped with an ON delay: The evaporator fan will cut in again after a delay of a few seconds on closure of the door.

Please note that no external voltage may be applied to the door contacts (connection clamps 5 and 6).

3 Product description

EN

3.2 Intended use, foreseeable misuse

The cooling unit is designed solely for cooling sealed enclosures (within the scope of validity covered by EN 60204, EN 61439 and UL 508A), and IT and tele-communications equipment (within the scope of validity covered by EN 62368) within the permitted temperature range, for indoor and outdoor use, and for professional use as defined in DIN EN 61000-3-2. Any other use is not permitted.

- Any form of use in potentially explosive areas, outside the permissible temperature range, on power supply systems not defined for this unit, on oil rigs and off-shore installations, on transport routes in tunnels, in commercial applications such as refrigeration chambers, refrigerated counters and kiosk coolers, as well as for room air-conditioning, is prohibited.
- The cooling unit is suitable for use in direct sunlight, snow, rain, sand, dust and condensation.
- The unit is designed solely for stationary use.

The cooling unit must not be used in environments with conductive, flammable and explosive dusts.

These include:

- Graphite dusts
- Metal dusts
- Cereal dusts
- Wood dusts
- Textile fibres and lint

The cooling unit is state of the art and built according to recognised safety regulations. Nevertheless, improper use can pose a threat to the life and limb of the user or third parties, or result in possible damage to the system and other property.

Consequently, the cooling unit must only be used properly and in a technically sound condition! Any malfunctions which impair safety should be rectified immediately.



Proper use also includes the observance of the documentation provided, and compliance with the inspection and maintenance conditions.

Rittal GmbH & Co. KG is not liable for any damage which may result from failure to comply with the documentation provided. The same applies to failure to comply with the valid documentation for any accessories used.

Inappropriate use may be dangerous. Examples of inappropriate use include:

- Use of the cooling unit over long periods with the enclosure open.
- Use of impermissible tools.
- Improper operation.
- Improper rectification of malfunctions.
- Use of accessories not approved by Rittal GmbH & Co. KG.

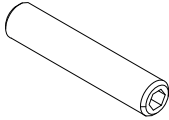

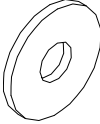
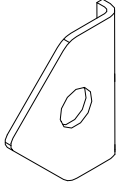
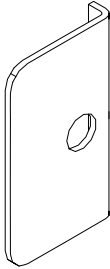
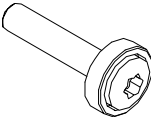
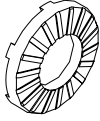
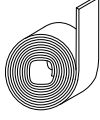

3.3 Scope of supply

Description	Illustration	SK 3485330	SK 3486330 SK 3487330	SK 3488340 SK 3489340
Enclosure cooling unit			1x	
Shipping bag with			1x	
– Assembly and installation instructions			1x	
– Grub screw M8 x 40 mm		6x	8x	
– Nut M8		6x	8x	
– Washer		6x	8x	
– Corner bracket			4x	
– L-shaped bracket		2x	4x	
– Screw M5x16		16x	20x	
– Serrated washer			2x	
– Sealing tape 10x10 mm		L = 2.7 m	L = 4.6 m	

Tab. 1: Scope of supply

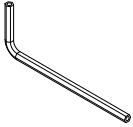
3 Product description

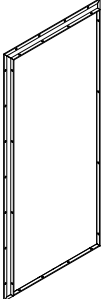
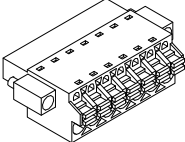
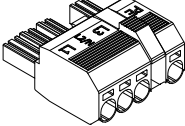
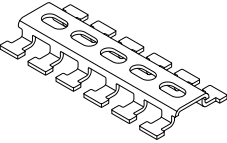
EN

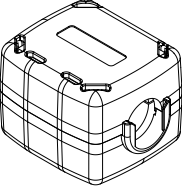
Description	Illustration	SK 3485330	SK 3486330 SK 3487330	SK 3488340 SK 3489340
– Torx wrench TX25			1x	
– Sealing section			1x	
– Mounting frame			1x	
– Signal connector			1x	
– Connector			1x	
– T-rail			1x	
– Connection box cover			1x	
– Ferrite core			1x	

Tab. 1: Scope of supply

4 Transport and handling

4.1 Delivery

The cooling unit is supplied in one packaging unit.

- Check the packaging carefully for signs of damage. Traces of oil on damaged packaging indicate a loss of refrigerant and/or a leak in the cooling unit. Any packaging damage may be the cause of a subsequent functional failure.

4.2 Unpacking

- Remove the packaging materials from the cooling unit.



Note:

After unpacking, the packaging materials must be disposed of in an environmentally friendly way.

- Check the cooling unit for any damage that may have occurred during transport.



Note:

Damage and other faults, e.g. incomplete delivery, should be reported immediately, in writing, to the shipping company and to Rittal GmbH & Co. KG.

- Check the supply contents for completeness (see section 3.3 "Scope of supply").

4.3 Transport

Depending on the chosen version, the cooling unit may weigh up to 73 kg.



Warning!

Please note the maximum weights that may be lifted by individuals. It may be necessary to use lifting gear.

There is a crane bracket pre-fitted to the top of the cooling unit. The cooling unit is readily transported with the aid of lifting gear and an indoor crane.



Note:

For the "external" mounting position (see section 5.3.5 "Fitting the cooling unit with a mounting frame"), the position of the crane bracket will need to be modified, otherwise the mounting frame cannot be screw-fastened to the cooling unit.

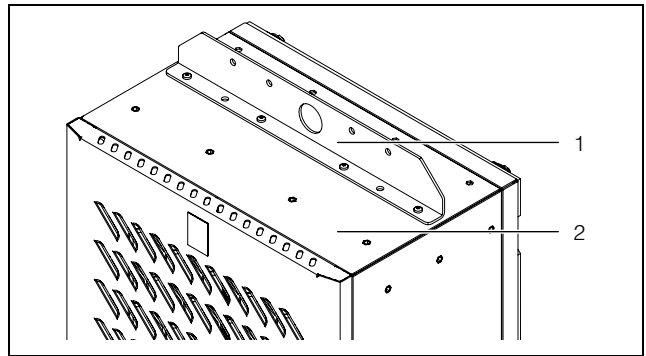

Fig. 3: Crane bracket on the top of the cooling unit

Key

- 1 Crane bracket
- 2 Housing

- Before transporting by crane, please ensure that the lifting gear and crane have sufficient load capacity to transport the cooling unit safely.
- Never allow anyone to stand beneath a suspended load, even for a short time, during transportation by crane.
- Protect the lifting gear on the crane hook from load deflection, because the load's centre of gravity may be off-centre.
- First position the cooling unit close to the installation site and protect from accidentally being knocked over.

Transport of a fitted cooling unit

- Shipping braces (such as a structure made from square timbers or boards – fig. 4 and fig. 5) must be used when transporting cooling units already mounted on the enclosure. These braces support the cooling unit and prevent it from slipping in case of impact.
- Use a sufficiently large pallet to prevent it from tipping over.
- If the cooling unit has been mounted on a door, close the door and keep it closed during transportation.

4 Transport and handling

EN

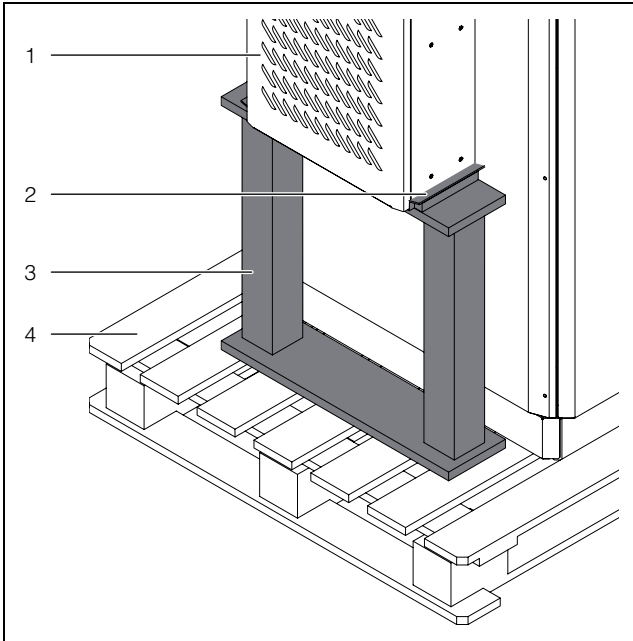

Fig. 4: External mounting of the shipping braces

Key

- 1 Fitted cooling unit
- 2 Bubble wrap
- 3 Supporting structure
- 4 Pallet underneath the cooling unit

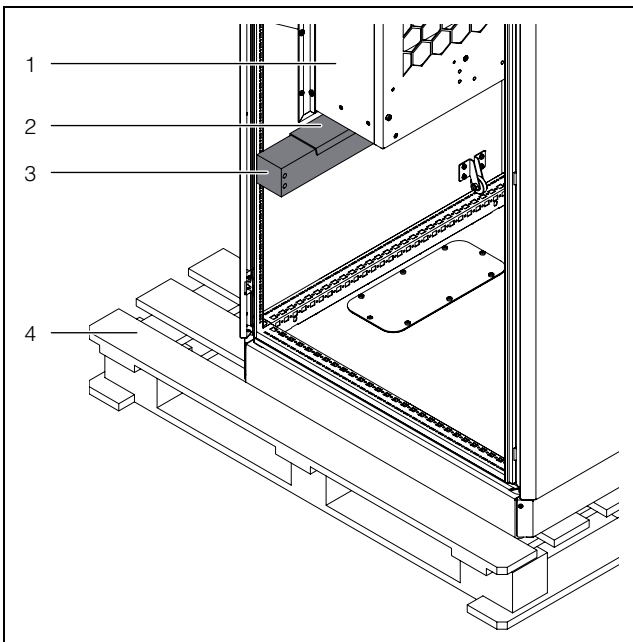

Fig. 5: Internal mounting of the shipping braces

Key

- 1 Fitted cooling unit
- 2 Bubble wrap
- 3 Supporting structure
- 4 Pallet underneath the cooling unit

5 Installation

5.1 Safety instructions

- Work on electrical systems or equipment may only be carried out by an electrician or by trained personnel under the guidance and supervision of an electrician. All work must be carried out in accordance with electrical engineering regulations.
 - The cooling unit may only be connected after the aforementioned personnel have read this information!
 - Use only insulated tools.
 - Follow the connection regulations of the appropriate electrical supply company. Otherwise, there is risk of injury from electric shock if the connection to the unit is defective or connected incorrectly in any way.
 - The cooling unit must be connected to the mains via an all-pole disconnecting device to overvoltage category III (IEC 61058-1).
 - The cooling unit is not de-energised until all of the voltage sources have been disconnected!
 - Do not assemble and re-activate the device until it is completely dry.
- Please note the maximum weights that may be lifted by individuals. It may be necessary to use lifting gear.
 - During assembly, the cooling unit is at risk of dropping through the mounting cut-out.
 - Always wear the required personal safety equipment when working on this device.
 - Please be sure to observe the applicable regulations governing electrical installations of the country in which the device is installed and operated as well as national regulations for accident prevention. Please also observe any internal company regulations, such as work, operating and safety regulations.
 - The technical specifications and limit values stated must not be exceeded under any circumstances. In particular, this applies to the specified ambient temperature range and IP protection category.

5.2 Siting location requirements

When choosing the installation site for the enclosure, please observe the following:

- The site for the enclosure, and hence the positioning of the cooling unit, must be carefully selected so as to ensure good ventilation (distance between cooling units at least 200 mm, distance from wall see distance "y" in fig. 6 or tab. 2).
- The cooling unit must be installed and operated with a maximum deviation of 2° from the vertical.
- The installation site must be free from excessive dirt and aggressive ambient conditions.
- The maximum humidity (non-condensing) must not exceed 95%.
- The ambient temperature must not fall below -30 °C/-22 °F or exceed +60 °C/140 °F.

- It must be possible to fit a condensate water discharge (see section 5.3.6 "Connect the condensate water discharge (optional)").
- The mains connection data as stated on the rating plate of the cooling unit must be guaranteed.

Size of installation room

- **Unit SK 3485.330** must not be installed in rooms of less than 3 m³.
- **Units SK 3486330 and SK 3487330** must not be installed in rooms of less than 6 m³.
- **Units SK 3488340 and SK 3489340** must not be installed in rooms of less than 12 m³.

Electromagnetic interference (EMI)

- Interfering electrical installations (high frequency) must be avoided.
- Signal cables must be laid separately from live cables (fig. 40).

Designing a suitable enclosure heater

Enclosure heaters are used to prevent the formation of condensation inside the enclosure, particularly with the type of fluctuating ambient temperatures that may occur with outdoor siting or in unheated rooms, and to maintain a constant minimum operating temperature (e.g. when the system is switched off overnight).

Enclosure heaters that regulate relative humidity, prevent temperatures from dropping below the dew point and stop condensation forming inside the enclosure. This in turn prevents consequential damages associated with corrosion and electrical short-circuits.

Rittal recommends you calculate the required enclosure heater, which should be used in conjunction with a hygrostat or enclosure internal thermostat. It is important to ensure that the enclosure internal temperature does not drop below -20 °C/-4 °F, because the internal fan will not operate below that temperature. In such cases, the error message "Ambient temperature outside" will appear on the display.

A sample calculation for the Rittal CS Toptec enclosure series is given below.

5 Installation

EN

Dimensions W x H x D mm	Required thermal output [W] at a minimal ambient temperature		
	-10 °C/14 °F	-20 °C/-4 °F	-30 °C/-22 °F
800 x 1200 x 800	350	530	720
800 x 1600 x 800	430	650	880
800 x 1800 x 800	480	810	960

5.3 Assembly procedure

5.3.1 Assembly instructions

- Before starting assembly, please ensure that the following tools are available:
 - Allen key SW4
 - Open-end spanner SW13
 - Torx screwdriver TX25
 - Phillips-head screwdriver
- Before assembling, please ensure that the enclosure is sealed on all sides (IP54 or Type 12). Increased condensation will occur later during operation if the enclosure is not airtight.
- If applicable, additionally fit a door limit switch (such as 4127010) to the enclosure which switches off the cooling unit when the enclosure door is opened to prevent excessive condensation (see section 3.1.6 "Door limit switch").
- Please ensure that the electronic assemblies in the enclosure allow the even circulation of air.
- Take care to ensure that the cooling unit and its surroundings are dry at the time of installation.
- Always have two people to lift the cooling unit, or preferably use lifting gear and an indoor crane. Ensure that it is secured against toppling over.
- Do not rest the cooling unit on the fitted mounting frame.
- Measure the distance "x" (fig. 6) from electronic components and other installed equipment inside the enclosure so that the required air circulation is not obstructed.

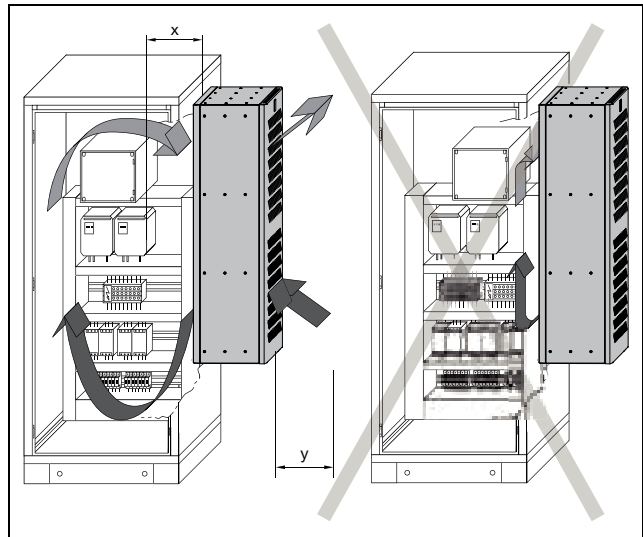

Fig. 6: Air circulation inside the enclosure

Model No.	Dimensions x and y [mm]
SK 3485330	175
SK 3486330, SK 3487330	165
SK 3488340, SK 3489340	225

Tab. 2: Dimensions "x" and "y"

- Under no circumstances should the air inlet and outlet openings of the cooling unit be obstructed. Only in this way is it possible to ensure that the maximum cooling output is available.
- Please ensure that the cold airflow from the cooling unit is not directed at active components.

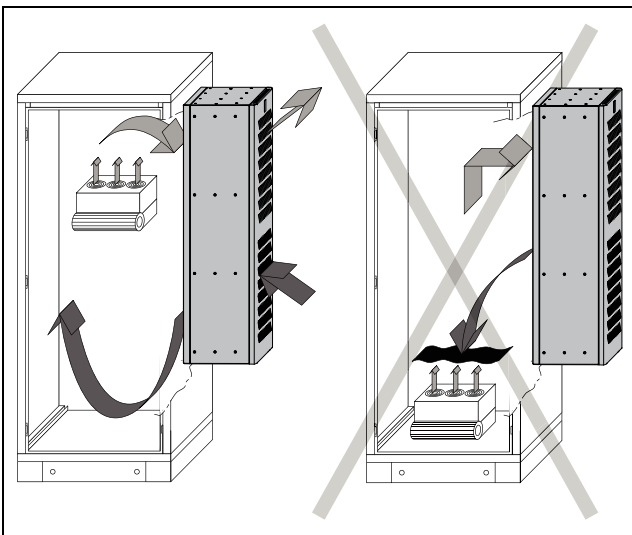

Fig. 7: Never direct the cold airflow at active components (example illustration)

- If appropriate, install components to divert the air.
- When installing in a dismantled door or side panel, please ensure that it cannot fall over when installing the cooling unit in the mounting cut-out.



Note:

- When mounting unit SK 3485330, the minimum dimensions of the enclosure are 600 mm x 1200 mm (width x height), both on the door and on the side panel.
- When mounting units SK 3486330, SK 3487330, SK 3488340 and SK 3489340, the minimum dimensions of the enclosure are 800 mm x 1800 mm (width x height), both on the door and on the side panel.



Note:

The pictures in this chapter illustrate the installation of the cooling unit in an enclosure door. Installation in a side panel is carried out in the same way.

Assembly is illustrated using unit SK 3485330 as an example. Variations for other units are labelled accordingly.

5.3.2 Mounting options

In principle, the cooling unit is suitable for mounting on single-walled and twin-walled enclosures. There are two different options for mounting the cooling unit on an enclosure door or side panel:

- Fitting **without** a mounting frame
- Fitting **with** a mounting frame

Fitting without a mounting frame

When mounted **without** a mounting frame, the cooling unit can only be externally mounted on single-walled en-

closure panels. In such cases, the entire cooling unit is outside the enclosure.

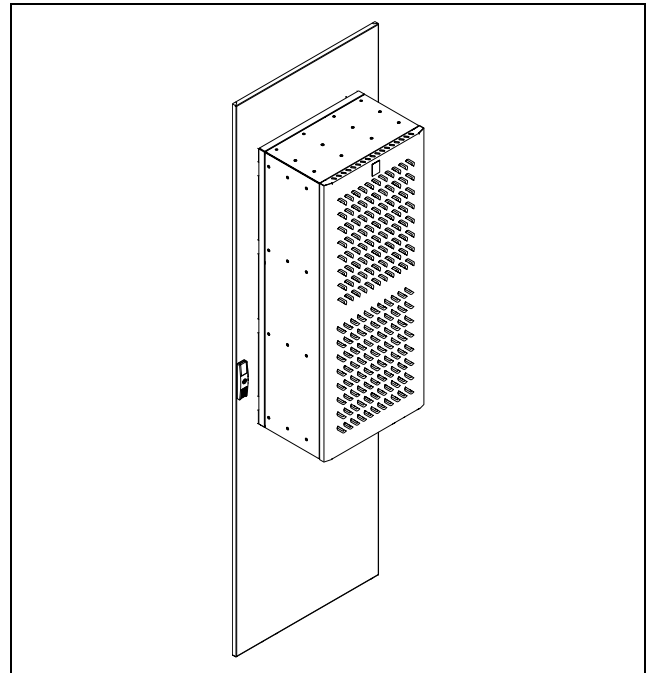

Fig. 8: Fitting without a mounting frame

Fitting with a mounting frame

When fitting **with** a mounting frame, there are three different mounting types, depending on where the mounting frame is positioned on the cooling unit:

- External mounting: All of the cooling unit is outside the enclosure.
- Partial internal mounting: Approximately half of the cooling unit's depth is inside the enclosure, and the other half is outside.
- Full internal mounting: All of the cooling unit is inside the enclosure. Only the cover projects to the outside.

5 Installation

EN

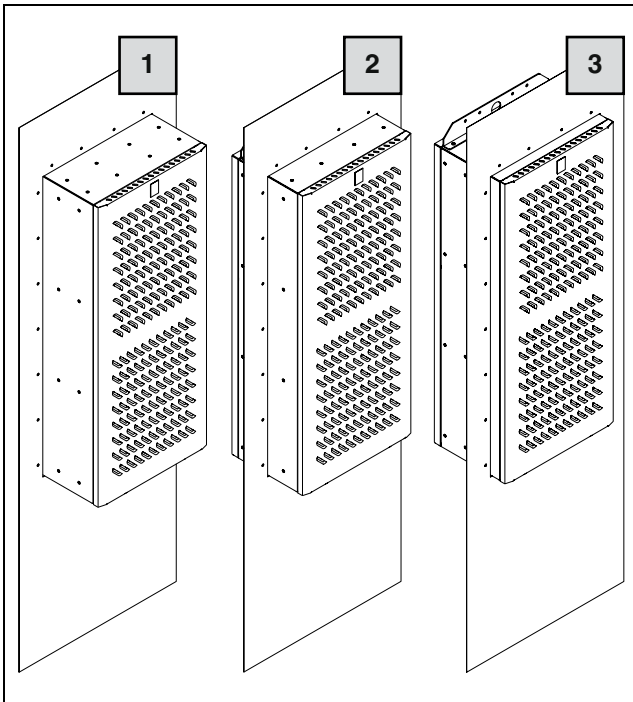

Fig. 9: Mounting options with a mounting frame

Key

- 1 External mounting
- 2 Partial internal mounting
- 3 Full internal mounting

Your chosen installation option will ultimately depend on how much space you require inside and outside the enclosure. The various mounting options have no influence on the cooling output of the cooling unit, which remains the same in all cases.

If there are a large number of components installed **inside the enclosure**, external mounting or partial internal mounting of the cooling unit may be appropriate. In such cases, the space inside the enclosure may be insufficient for full internal mounting, or it may not be possible to guarantee adequate cooling of all components inside the enclosure.

5.3.3 Make a mounting cut-out in the enclosure Twin-walled enclosure

For mounting on a twin-walled enclosure, the appropriate door or side panel must be purchased from Rittal.

- Please contact us to discuss your requirements.

Single-walled enclosure

For mounting on a single-walled enclosure, a suitable mounting cut-out must be made. The mounting cut-out is the same for all three mounting options, but differs depending on whether it is fitted with or without a mounting frame.



Note:

The dimensions of the mounting cut-outs can be found in sections 12.1 "Mounting cut-outs on single-walled enclosure panels without a mounting frame" and 12.2 "Mounting on single- and twin-walled enclosure panels with a mounting frame".

- Using the diagrams, calculate the required dimensions for your mounting cut-out.
- Drill all the required holes and make the mounting cut-out.
- Carefully deburr all drilled holes and the cut-out to prevent injuries caused by sharp edges.



Caution!

There is a risk of injury on sharp cut-outs which have not been properly deburred, especially while mounting the cooling unit.

5.3.4 Fitting the cooling unit without a mounting frame

- Cut the sealing tape provided in the dispatch bag to the required length so that it can be placed all around the rear of the cooling unit.
- Start by sticking the sealing tape at the bottom edge, so that the joint between the two ends of the sealing tape is likewise on the bottom edge of the unit.
- Carefully stick the sealing tape onto the rear. Carefully go round the screw heads on the inside, as this is the only way to ensure continuous sealing against the enclosure.

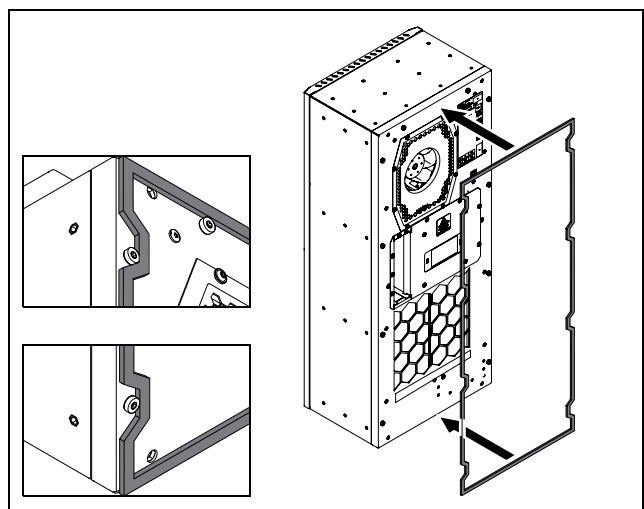

Fig. 10: Laying the seal

- Screw the two grub screws into the blind threaded bushes at the bottom rear of the cooling unit ($M_A = 5 \text{ Nm}$).

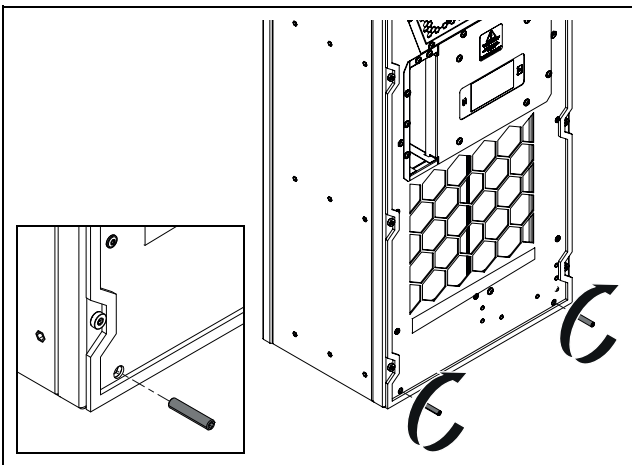

Fig. 11: Tighten the grub screws at the bottom

- In the same way, screw two grub screws into the blind threaded bushes at the top rear of the cooling unit ($M_A = 5 \text{ Nm}$).

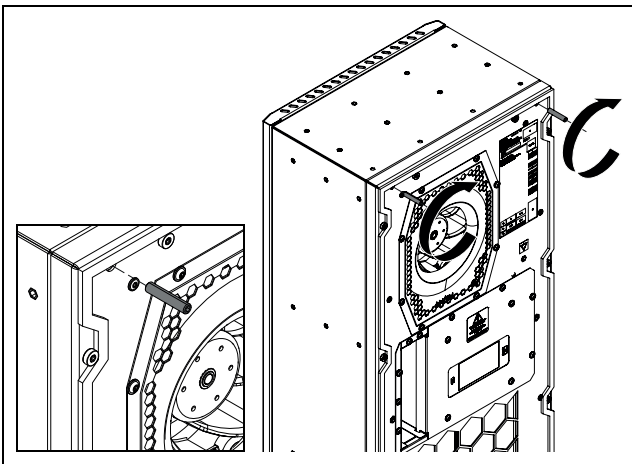

Fig. 12: Tighten the grub screws at the top



Note:

In the subsequent step, take care to ensure that the cooling unit is only resting on the grub screws, never on the sealing tape, otherwise it could become damaged.

- Lift up the cooling unit, preferably from a crane bracket using suitable lifting gear, and initially set the cooling unit down with the two bottom grub screws on the door or side panel of the enclosure.

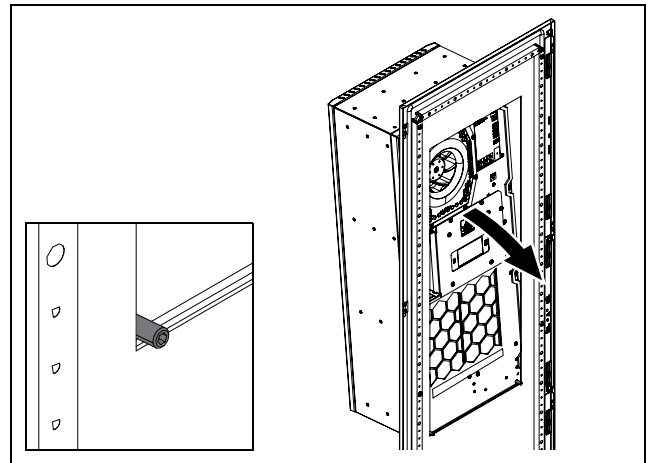

Fig. 13: Lower the cooling unit into the mounting cut-out

- Attach the two corner brackets to the top grub screws and secure with the corresponding washers and hex nuts ($M_A = 5 \text{ Nm}$). Pay particular attention to the correct orientation of the corner brackets.

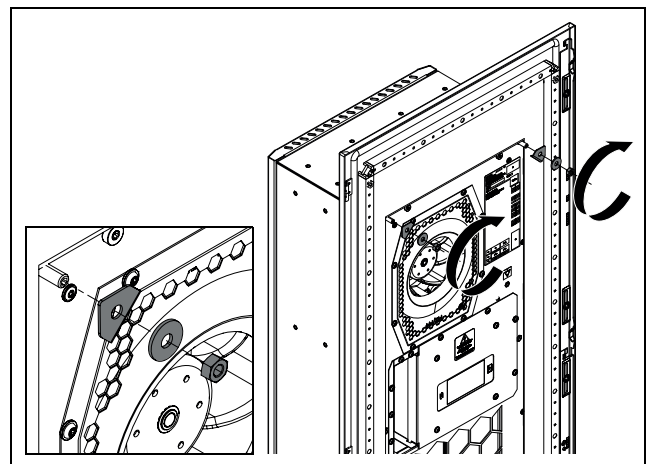

Fig. 14: Fit the top corner brackets

- Next, attach the two corner brackets to the bottom grub screws and secure with the corresponding washers and hex nuts ($M_A = 5 \text{ Nm}$). Once again, pay particular attention to the correct orientation of the corner brackets.

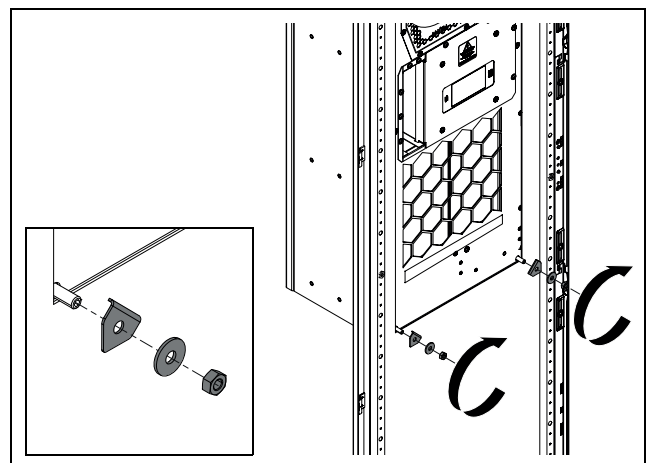

Fig. 15: Fit the bottom corner brackets

5 Installation

EN

- For SK 3485330: In the centre, screw two grub screws into the blind threaded bushes around halfway up the cooling unit.

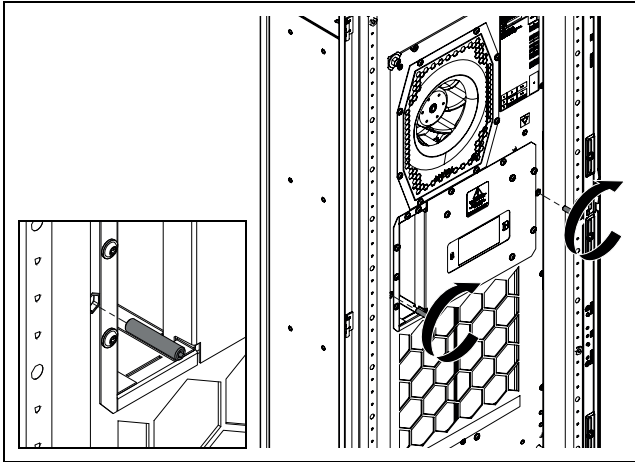

Fig. 16: Tighten the central grub screws

- For SK 3486330, SK 3487330, SK 3488340, SK 3489340: In the centre, screw four grub screws into the blind threaded bushes around halfway up the cooling unit.

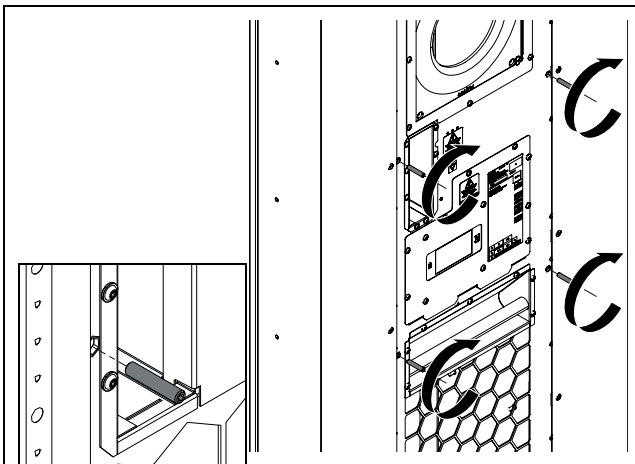

Fig. 17: Tighten the central grub screws

- For SK 3485330: Next, attach the two L-shaped brackets to the grub screws and secure with the corresponding washers and hex nuts ($M_A = 5 \text{ Nm}$). Once again, pay particular attention to the correct orientation of the L-shaped brackets.

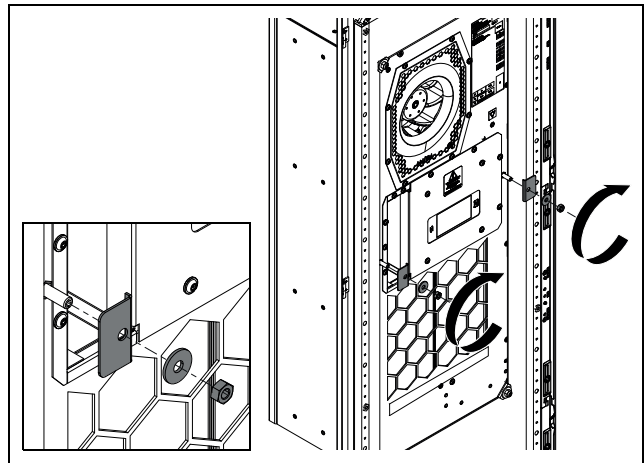

Fig. 18: Fit the central L-shaped brackets

- For SK 3486330, SK 3487330, SK 3488340, SK 3489340: Next, attach the four L-shaped brackets to the grub screws and secure with the corresponding washers and hex nuts ($M_A = 5 \text{ Nm}$). Once again, pay particular attention to the correct orientation of the L-shaped brackets.

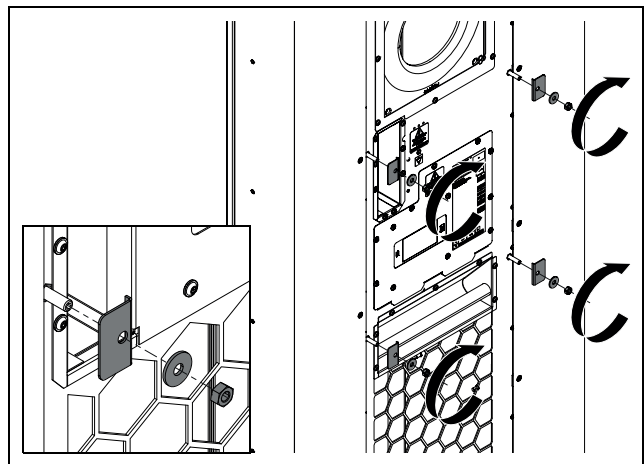

Fig. 19: Fit the central L-shaped brackets

5.3.5 Fitting the cooling unit with a mounting frame

- Please observe the following instructions:
 - Full internal mounting of the cooling unit is illustrated below. External mounting and partial internal mounting are performed in the same way, except that the mounting frame is positioned differently on the cooling unit.
 - Furthermore, for external mounting, the crane bracket on the cooling unit will need to be moved.
 - When mounting on a single-walled enclosure with mounting frame, screws with an under-head gasket or blind rivet nuts may be used. Please contact Rittal if you require further information.
 - The attachment points and mounting cut-out are already provided on the enclosure panel for mounting on a twin-walled Rittal enclosure with mounting frame.

- All suitable enclosures with mounting cut-outs can be found on the Rittal website.
- The customer is responsible for ensuring appropriate mounting on the enclosure.

The mounting frame is included with the cooling unit supply. The following positions are possible, depending on the installation position of the cooling unit.

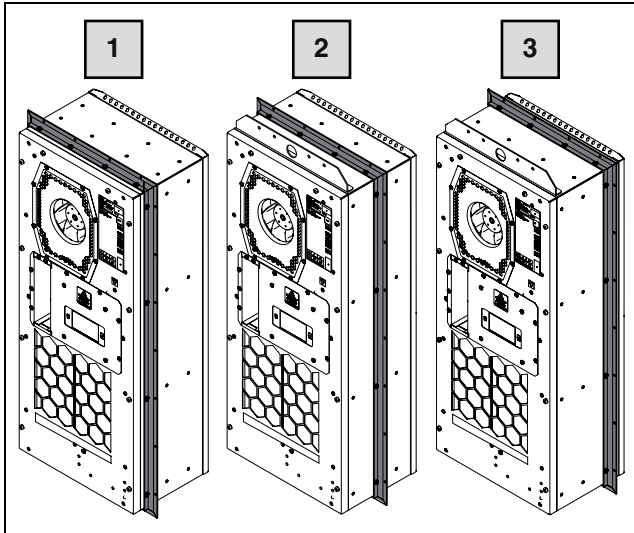



Fig. 20: Possible positions of the mounting frame

Key

- 1 Rear position for external mounting
- 2 Central position for partial internal mounting
- 3 Front position for full internal mounting

- Set the cooling unit down on a suitable surface on its back, taking care not to damage the unit.

Note:
 **Never** place the cooling unit on its cover when fitting the mounting frame.

- Remove the mounting frame from the packaging and position it in the required mounting position on the cooling unit.

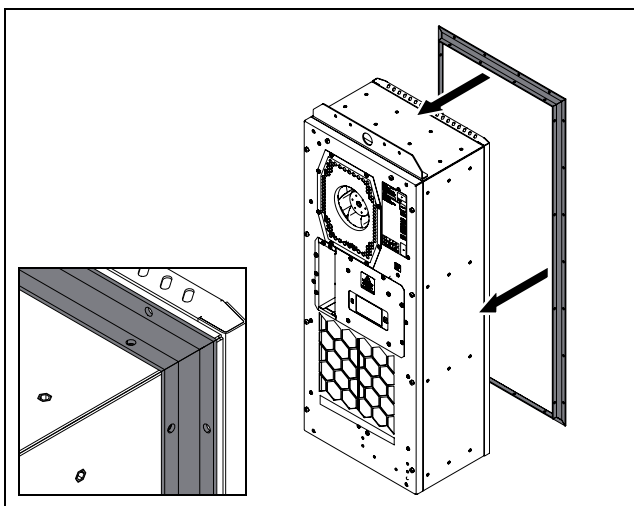

Fig. 21: Position the mounting frame

- For SK 3485330: Secure the mounting frame in the desired position using the 16 assembly screws included with the supply ($M_A = .5 \text{ Nm}$).

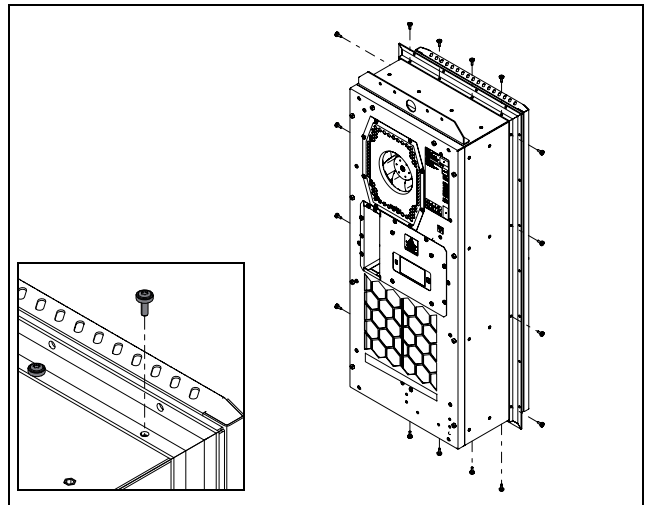

Fig. 22: Secure the mounting frame to the cooling unit

- For SK 3486330, SK 3487330, SK 3488340, SK 3489340: Secure the mounting frame in the desired position using the 20 assembly screws included with the supply ($M_A = 3.5 \text{ Nm}$).

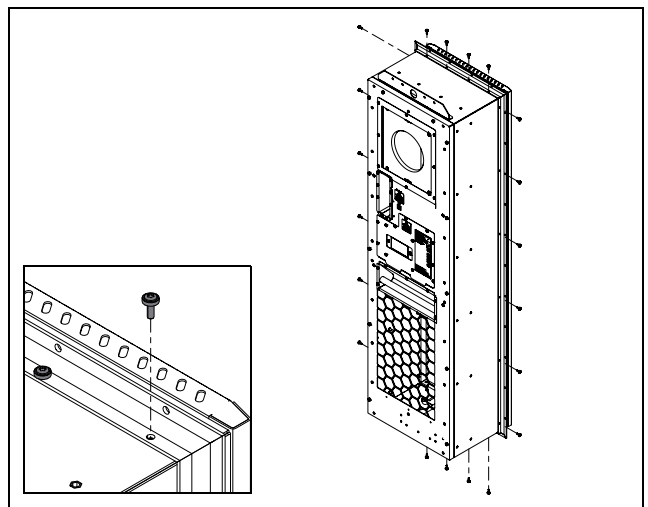

Fig. 23: Secure the mounting frame to the cooling unit

- Using a clean, lint-free fabric or cellular cloth, lubricate the seal included with the supply with Vaseline or acid-free oil.
- Working from the front, slide the seal over the cooling unit.

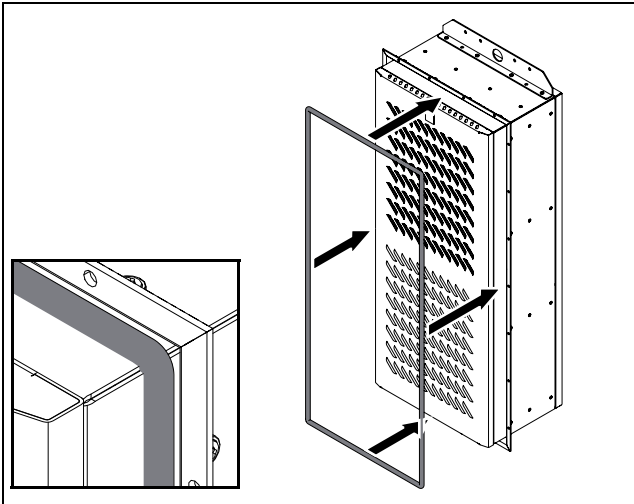

Fig. 24: Slide over the seal position

- Ensure that the seal has been pressed into the mounting frame around the entire circumference.
- Lift up the cooling unit, preferably from a crane bracket using suitable lifting gear, and set the cooling unit and mounting frame down on the door or side panel of the enclosure.

Single-walled panels with a mounting frame

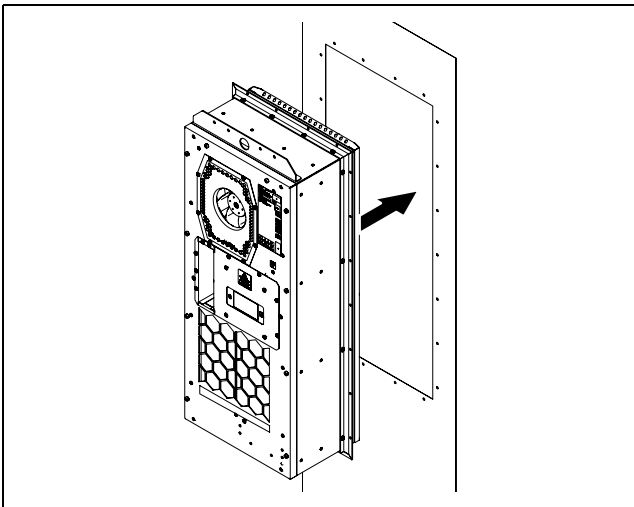

Fig. 25: Inserting the cooling unit into a single-walled enclosure panel

Twin-walled panels with a mounting frame

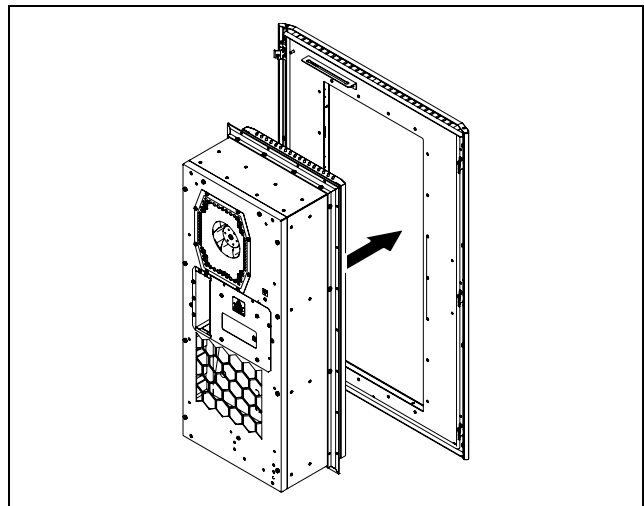

Fig. 26: Inserting the cooling unit into a twin-walled enclosure panel

Attachment with single- and twin-walled enclosure panels

- Secure the mounting frame (and hence the cooling unit) to the door or side panel, e.g. using suitable screws with washers to ensure a perfect seal between the frame and the enclosure door or side panel. Only loosely tighten the screws to begin with, then tighten crosswise with the required torque, depending on the type of fastening.
- Create potential equalisation between the mounting frame and the door or side panel using a suitable PE conductor connection and the serrated washer included with the supply.
- If applicable, finally, re-attach the door or side panel to the enclosure if not mounting directly on the enclosure.

5.3.6 Connect the condensate water discharge (optional)

There is a condensate water evaporator fitted in the external circuit of the cooling unit. With an enclosure connected, this condensate water evaporator may typically evaporate condensate water volumes of up to 100 ml/h. If larger quantities of condensate water are produced, a condensate water discharge hose may additionally be fitted. This hose allows condensate water to be routed out of the cooling unit pressurelessly. A suitable hose is available as an accessory from Rittal (see section 13 "Accessories").

Please follow the instructions given below:

- The hose must be laid with an adequate and constant gradient to prevent siphoning.
- The hose must be laid without any kinks.
- If extended, the cross-section of the hose must not be reduced.
- The hose should be routed to a drain or external condensate water evaporator by the customer.

- Using the special TX25 torx wrench from the dispatch bag, loosen the three assembly screws underneath the cover and pull them off downwards.

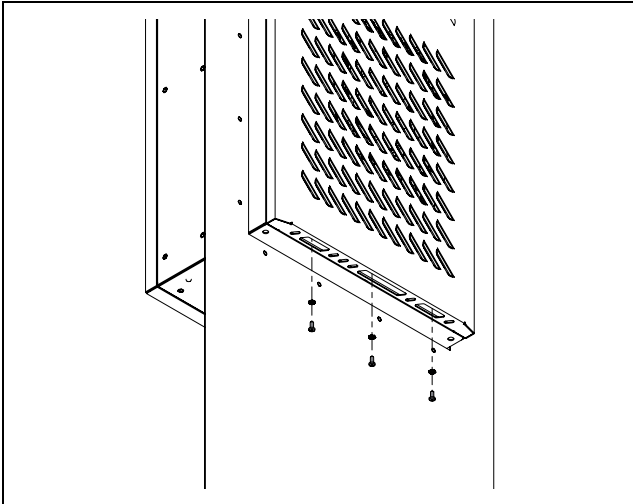

Fig. 27: Loosen the assembly screws

- Raise the cover slightly and gently pull it forwards away from the enclosure.

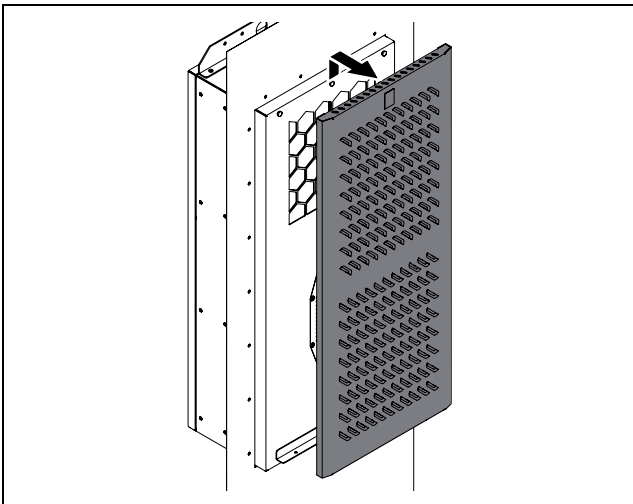

Fig. 28: Raise the cover

- Then swing the cover gently to the side.

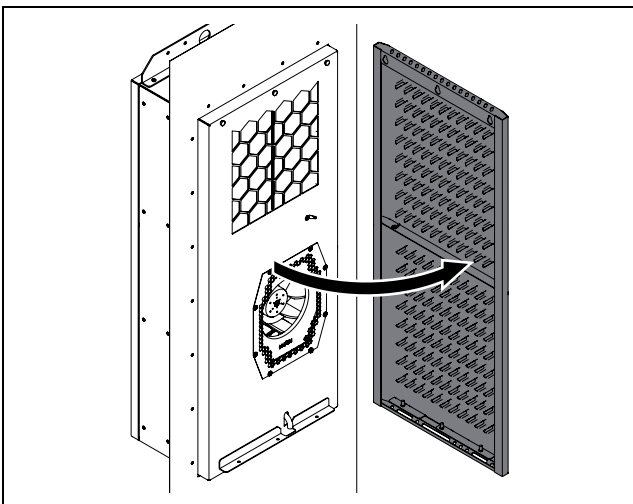

Fig. 29: Swing the cover sideways

- The PE conductor connection between the cover and the chassis is located on the right-hand side, around half-way up.
- Disconnect the flat-pin connector of the internal PE conductor, preferably on the enclosure, then remove the cover completely from the unit.
- Connect a suitable hose to the condensate discharge nozzle and secure using a hose clamp.

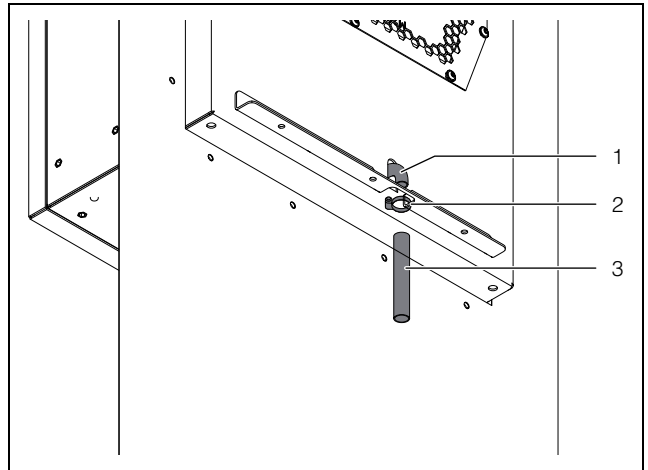

Fig. 30: Connection for condensate discharge hose

Key

- 1 Connection point
- 2 Hose clamp
- 3 Hose

- Lay the hose as per the instructions above.
- Re-fit the cover onto the enclosure in the reverse order.
- Please note, it is important to ensure that the PE conductor connecting the cover to the enclosure is connected at both ends.

5.4 Electrical connection

5.4.1 Notes on electrical installation

- When carrying out the electrical installation, it is important to observe all valid national and regional regulations as well as the provisions of the responsible power supply company.
 - Electrical installation must only be carried out by a qualified electrician who is responsible for compliance with the existing standards and regulations.
 - All cables routed into the wiring compartment have to be insulated for the maximum voltage of the power supply.

Connection data

- The connected voltage and frequency must correspond to the ranges stated on the rating plate. The units support multiple voltages.
- The cooling unit must be connected to the mains via an all-pole disconnect to overvoltage category III (IEC 61058-1).

5 Installation

EN

- The unit is intrinsically safe and does not require any additional external safety devices for safe operation.
- The connection cable must be protected with a miniature circuit-breaker.
- To ensure the proper functioning of internal pressostats in the event of a malfunction, a line fuse of no less than 15 A is required.
- If a motor circuit-breaker or circuit-breaker is used, it should be selected in accordance with EN 60898-1.
- For applications in UL-approved facilities, any CCMR-type fuse from Littelfuse may be used, or alternatively, a UL-certified air circuit-breaker.
- Suitable miniature circuit-breakers and circuit-breakers can be found under Rittal accessories (see section 10 "Technical specifications" and section 13 "Accessories").
- Thanks to the integral inverter technology, conventional start-up currents (start-up of internal motors) are not externally visible.
- The mains infeed and the signal cable may optionally be of a shielded design. The cable shield may be contacted at the potential equalisation point.
- No additional temperature control may be connected upstream of the unit at the supply end
- Low-noise potential equalisation must be guaranteed with the mains connection.

Overvoltage protection and supply line load

Rittal recommends the following measures for protecting the cooling units in non-standard environmental and connection conditions.

- The unit does not have its own overvoltage protection. Measures must be taken at the supply end by the switchgear manufacturer or operator to ensure effective protection against lightning and overvoltage.
- Overvoltage protection must be installed upstream of the infeed to the cooling units and not immediately after the infeed to the entire enclosure. This is the only way to ensure that surge pulses generated by the machine itself are discharged.
- The units are classified as overvoltage category III and meet the requirements of EN 60204-1 on the electrical equipment of machines. The mains voltage must not deviate by more than the tolerance specified in section 10 "Technical specifications".
- The discharge current may exceed 3.5 mA.
- The units are high-voltage tested ex works. An additional high voltage test must only be carried out with a DC voltage supply source (1500 VDC max.).
- EMC interference signals arising in local industry and plant networks may deviate significantly from those specified in the standards. In these types of network situations, an external EMC filter should be used.
- If the combined output of the frequency converters, power converters or transformers in the network where the device is being operated is >70 kVA, the customer must connect a Class II surge voltage pro-

tector in the mains supply line upstream of the cooling unit. The surge voltage protector must be designed to EN 61800 -1. The following values may be assumed as starting-points for the design:

Transformers, power electronics	Assumed discharge energy
70 kVA...100 kVA	40 J
100 kVA...200 kVA	80 J
200 kVA...400 kVA	160 J
400 kVA...800 kVA	320 J

Tab. 3: Design of the surge voltage protector

Technical specifications for a suitable overvoltage protection module:

- Terminal voltage $U_c = 350...400$ V, 50/60 Hz
- Maximum current $I_{max} = 40$ kA
- Rated current $I_n = 20$ kA
- Breakdown voltage $U_p = 1.75$ kV

Three-phase devices

- There is no need to observe a counterclockwise or clockwise phase rotation when making the electrical connection to a three-phase voltage supply. The electronics incorporated into the devices automatically create the required phase rotation.
- In three-phase devices, the absence of a phase is detected, and the device is switched off.
- Outgoing equipment is monitored by the inverter, and deactivated in the event of a malfunction in the electricity supply.

SCCR – Short-circuit resistance

Under UL508A Supplement SB, the standard SCCR for cooling units is 5 kA.

If the device is installed on a UL508A feeder circuit >5 kA, a protective device with the corresponding SCCR of the feeder circuit and a peak let-through of <5 kA should be connected upstream in the cooling unit branch.

Door limit switch

- Each door limit switch can only be assigned to one cooling unit.
- Several door limit switches may be operated in parallel with one cooling unit.
- The minimum cross-section for the connection cable is 0.3 mm² for a cable length of 2 m.
- The line resistance to the door limit switch must not exceed a maximum of 50 Ω.
- The maximum admissible line length is 10 m.
- The door limit switch only supports a floating connection; no external voltages.

- The contact of the door limit switch must be closed when the door is open.
- The safety extra-low voltage for the door limit switch is provided by the internal power pack: Current approx. 5 mA DC.
- Connect the door limit switch to terminals 5 and 6 of the signal connector.

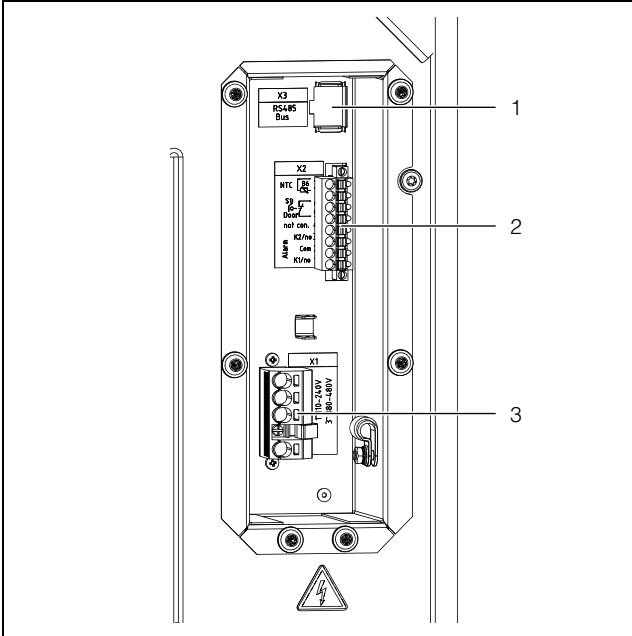

Fig. 31: Connections at rear (example illustration)

Key

- 1 Connection for IoT interface 3124.300 (X3)
- 2 Connection for signal connector (X2)
- 3 Connection for mains connector (X1)

Ferrite core

- Attach the ferrite core (1x for SK 3485330 as shown in fig. 32 and 2x for SK 3486330, SK 3487330, SK 3488340, SK 3489340 as shown in fig. 33) included with the supply to the signal cables near the connector to prevent interference with signal transmission. The cables should be looped around the ferrite core.

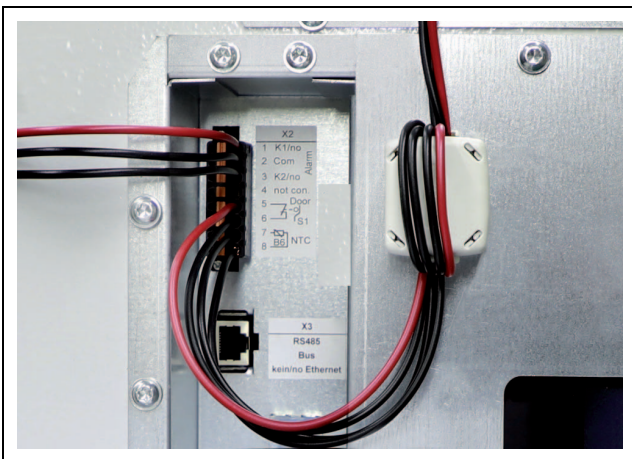

Fig. 32: Mounting point for the ferrite core on SK 3485330



Fig. 33: Mounting point for the ferrite cores on SK 3486330, SK 3487330, SK 3488340, SK 3489340

Potential equalisation

If, for EMC reasons, the unit is to be integrated into the customer's existing potential equalisation system, a conductor may be connected to the potential equalisation connection point. The connection point is labelled with the required switch symbol.

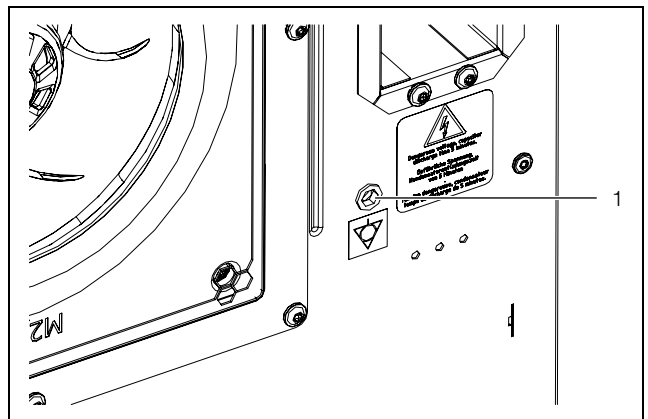

Fig. 34: Connection point for potential equalisation (example illustration)

Key

- 1 Connection point M6

- Attach the potential equalisation to the unit's connection point using the screw, washer and contact washer.

5 Installation

EN

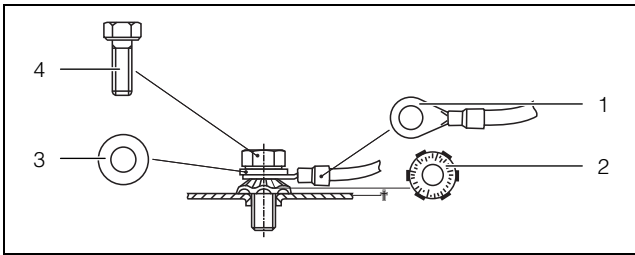

Fig. 35: Potential equalisation arrangement

Key

- 1 Ring terminal with PE conductor
- 2 Contact washer
- 3 Washer
- 4 Screw



Note:
According to the standard, the PE conductor in the mains connection cable is not classed as an equipotential bonding conductor.

5.4.2 Install the power supply



Note:
– We recommend that the power supply cable and the signal cable should be of a shielded design.
– The cable shield can make contact with the T-rail (fig. 39).

- Remove the mains connector from the dispatch bag and connect to the mains as shown on the connection diagram (fig. 37 or fig. 38).
- Use copper conductors only to connect the supply cable to the mains connector.



Note:
The cover may optionally be secured over the electrical connection to provide protection. In IT and container applications, covers must always be secured ($M_A = 2 \text{ Nm}$).

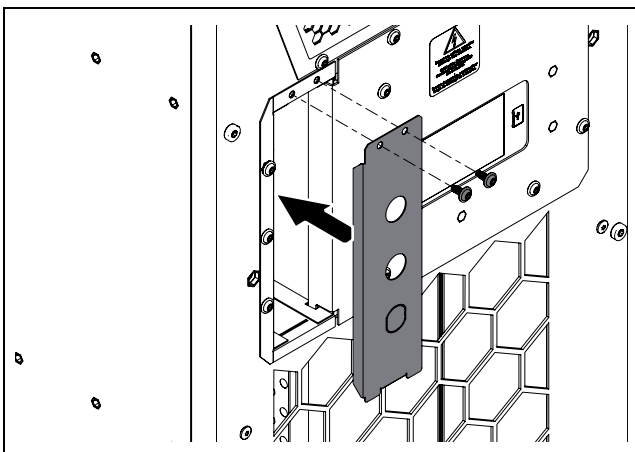

Fig. 36: Fitting the cover

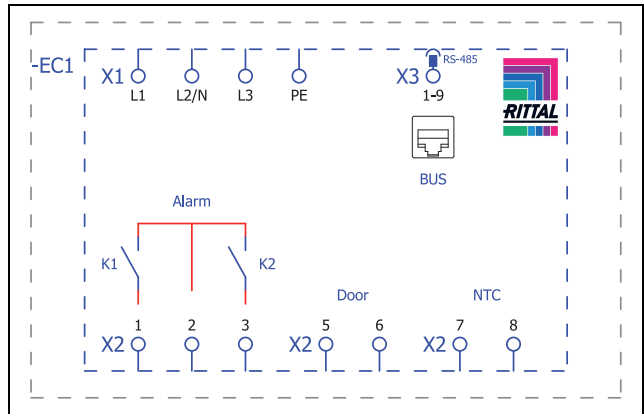

Fig. 37: Circuit diagram SK 3485330, SK 3486330, SK 3487330

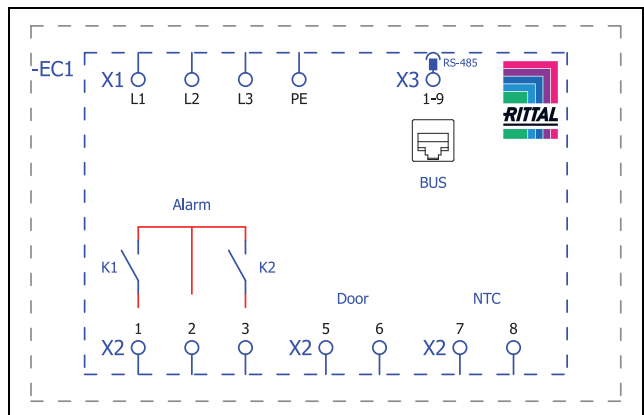

Fig. 38: Circuit diagram SK 3488340, SK 3489340

Key

- X1 Main terminal strip
- K1 Alarm relay 1
- K2 Alarm relay 2
- Door Door limit switch (optional, without door limit switch: terminal 5, 6 open)
- NTC External temperature sensor (optional)
- X3 RS 485 interface

Attachment option for cable routing

- Remove the T-rail from the pack and attach it to the connection unit.

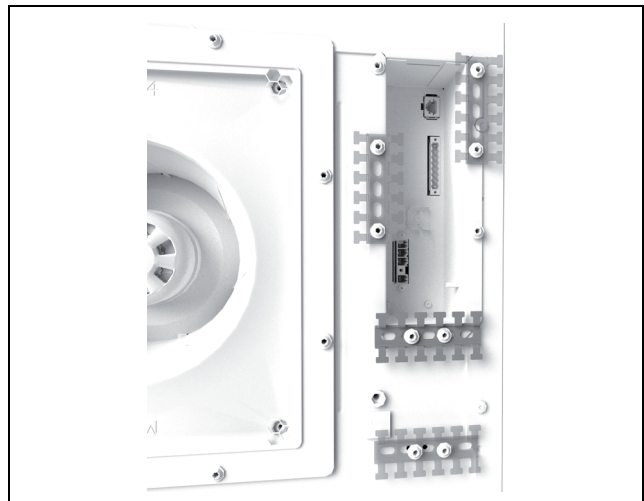

Fig. 39: Attach the T-rail (example illustration)

- Then create the strain relief.



Fig. 40: Create the strain relief using cable ties (example illustration)

5.4.3 Connect the alarm relays

System messages from the cooling unit may be output to an external signal source via two floating relay outputs.

The relay outputs are in the de-energised state NO (Normally Open). As soon as voltage is applied to the cooling unit, the alarm relays will pick up. This is the factory setting for the cooling unit's normal operating state. Whenever a system message occurs or the power supply is interrupted, the alarm relays will drop out and open the contact.

- Connect a suitable connection cable to the connection terminals 1 (Alarm K1) and/or 3 (Alarm K2) of the signal connector (X2).
- Configure the alarm relays you wish to use to output error messages (see section 7.4.3 "Alarm relays").

AC $\cos \phi = 1$	DC Res. Load
I max. = 2 A U max. = 250 V	I min. = 100 mA U max. = 30 V I max. = 2 A

Tab. 4: Contact data

5.4.4 Interfaces

The cooling unit has the following interfaces, located on the rear, for communicating with external systems:

- Micro-USB interface
- RS 485 interface
- NFC interface

Micro-USB interface

A micro-USB interface is located on the rear, to the right of the display. A laptop may be connected here to update the device.

- To update the device, connect a laptop with installed software to the micro-USB interface.

No other USB devices will be detected on this connection.

RS 485 interface

An RS 485 interface is located on the rear of the connection box. The IoT interface for linking the cooling unit to the customer's own monitoring, energy management and/or superordinate systems may be connected here.

- Connect the the IoT interface (accessory) to the RS 485 interface (X3).



Note:

A direct connection to the cooling unit via the RS 485 interface is not possible.

NFC interface

The cooling unit may be accessed with the "Rittal Scan & Service" app via the integral NFC interface to the left of the display. Access is only possible with the app supplied by Rittal (see section 13 "Accessories").

6 Commissioning

EN

6 Commissioning



Note:

The oil must collect in the compressor in order to ensure adequate lubrication and cooling. For this reason, do not operate the cooling unit for at least 30 minutes after assembling the equipment.

- Observe the aforementioned waiting period of at least 30 minutes before commissioning the unit after assembly.
- Next, switch on the voltage supply to the cooling unit. The Rittal logo will initially appear on the display, followed a short time later by the start screen.
- You can now make your individual settings on the unit, e.g. set the temperature or assign the network identifier, etc. (refer to chapter 7 "Operation").



Note:

It is **not** necessary to carry out leak or pressure tests on the cooling unit prior to commissioning. Rittal has already done this in the factory.



Note:

The current software version is shown on the display (see section 7.3.2 "Device information").

Before commissioning, Rittal recommends checking the Rittal website for any software updates. The current firmware and a program for updating the firmware are available for downloading on the relevant product pages of the Rittal website.

- Install the latest firmware to access the full range of functions below.
-

7 Operation

7.1 General

The cooling unit is equipped with a touch function display for making basic settings and displaying error messages. This is an industrial-grade touch display which is pressure-sensitive and may therefore be operated with gloves.

As well as operating directly on the cooling unit itself, there is also a smartphone app available. This offers almost the same functions as the actual display, and additionally provides extended explanations of error messages, as well as the option of contacting the Rittal Service team directly.



Note:

The current firmware and a program for updating the firmware are available for downloading on the relevant product pages of the Rittal website.

- Install the latest firmware to access the full range of functions below.

7.2 Layout of the display

The display is divided into a top section on a dark background, and a bottom section with the menu bar. This layout is always identical, but the content of the two sections will vary according to the menu selected.

7.2.1 Start screen

The start screen is always displayed while the cooling unit is in normal operation, provided there are no error messages.

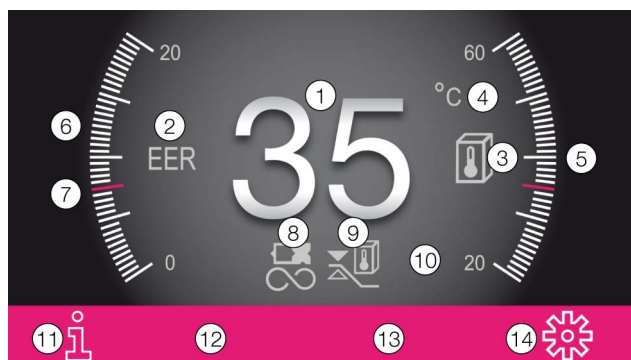

Fig. 41: Layout of the start screen

Key

Item	Description	Possible icons
1	Internal temperature display (2-digit °C/3-digit °F)	Numbers from 0-9
2	EER scale: Range 0...20 / current average EER value of the last 24 hours	EER

Tab. 5: List of all icons with descriptions

Item	Description	Possible icons
3	Ti scale: Range 20 ...60 / value: Average enclosure internal temperature of the last 24 hours	
4	Display temperature unit	°C °F
5	USB connection (if connected)	
6	Self-test (if initiated)	
7	NFC connection (max. 120 seconds after connecting)	
8	Type of cooling	
9	Control based on ...	
10	External sensor	
11	Information menu	
12	System messages (where applicable)	
13	Service icon (if required)	
14	Configuration	

Tab. 5: List of all icons with descriptions

Type of cooling

The current form of cooling is indicated by one of the following four icons.

Symbol	Parameters
	Cooling in compressor mode without support from the heat pipe
	Cooling in compressor mode with support from the heat pipe
	Cooling via the heat pipe only
	No cooling

Tab. 6: Possible icons for the current type of cooling

7 Operation

EN

7.2.2 Changing a parameter value

If a parameter value is changed, the display including the menu bar will also change.



Fig. 42: Screen for changing a parameter value

Key



- 1 Main screen
- 2 Control bar

The currently selected parameter value is displayed in the centre of the main screen. To change this value, you always proceed in the same way, as described below with the example of adjusting the set temperature:

- On the start screen, click on the "Configuration" button.
- Enter the PIN to gain access to the lower-level screen pages of the "Configuration" zone. "22" is the default PIN.
- Click on the "Temperature" symbol.
- Click on the "Control mode" symbol.
- Select your preferred control mode from the display.
- Change the setting to the required temperature using the "Up" and "Down" arrows.
- Alternatively, you can also select the one of the displayed higher or lower values directly.
- Finally, confirm the set value with "OK".
- Exit this screen page with the "Back" button.

7.3 Information menu

- Click on the "Information" symbol to display a list of lower-level screen pages.



Symbol	Parameters
	Temperature info
	Device info
	Efficiency info

Tab. 7: "Information" zone

7.3.1 Temperature information

- Click on the "Temperature information" symbol.









The ambient temperature and internal temperature are displayed, in each case as an average for the last 24 hours of operation.

Symbol	Parameter
	ØTU 24h Average ambient temperature (external temperature) over the last 24 hours of operation.
	ØTI 24h Average internal temperature over the last 24 hours of operation.

Tab. 8: "Temperature information" zone

7.3.2 Device information

- Click on the "Device information" symbol.
A list of general information about the device will be displayed.
- Page through the list using the "Up" and "Down" arrows.

Symbol	Parameter
	Serial number
	Manufacture date YYYY-MM-DD
	Hardware Release x.xx.xx
	Firmware Release x.xx.xx
	Software Release x.xx.xx
	Last update YYYY-MM-DD
	Last maintenance YYYY-MM-DD
	User device name Name assigned to the cooling unit by the customer. The name can be assigned via the "Rittal Scan & Service" app to distinguish between individual devices.
	Act. control mode

Tab. 9: "Device information" zone

7.3.3 Efficiency information

- Click on the "Efficiency information" symbol.

The average energy efficiency ratio (EER) for the last 24 hours of operation will be displayed. The energy efficiency ratio is the ratio of the cooling output generated to the electrical power used.

Symbol	Parameter
EER	Average EER 24h Average energy efficiency ratio (EER) of the last 24 hours of operation.

Tab. 10: "Efficiency information" zone

7.4 Configuration menu

- Click on the "Configuration" symbol.

A screen page will appear asking you to enter the PIN in order to access the lower-level screen pages.



Note:

"22" is preset in the factory as the default PIN.

- For the first digit, page through the digits "0" to "9" using the "Up" and "Down" arrows until the required digit appears in the box.
- Confirm your selection with "OK".
- For the second digit, once again page through the digits "0" to "9" using the "Up" and "Down" arrows until the required digit appears in the box.
- Confirm your selection with "OK".

A list of lower-level screen pages will be displayed.

Symbol	Parameter
	Temperature Settings for set temperature and control mode
	Network Display of network information from the IoT interface (3124300)
	Alarm relay Settings for the alarm relays.
	Filter mats (no function)
	Display language Choice of language for display texts.
	Self-test Perform a self-test.

Tab. 11: "Configuration" zone

7.4.1 Temperature

- Click on the "Temperature" symbol to display a list of lower-level screen pages.

Symbol	Parameter
	Change unit Set the unit "°C" or "°F"
	Control mode
	Alarm threshold Temperature limit which will trigger an alarm message if exceeded.

Tab. 12: "Temperature" zone

Change unit

All temperature values for the unit may be displayed either in degrees Celsius "°C" or degrees Fahrenheit "°F".

- Click on the "Change unit" symbol.
- Change the required unit ("°C" or "°F") using the "Up" or "Down" arrows.
- Confirm your entry with "OK".

Control mode

The cooling unit controls cooling output according to one of the following three temperature values:

- Inside temp. (factory setting):** The temperature at which air is drawn out of the enclosure into the cooling unit.
- External sensor:** The temperature measured with an external temperature sensor at a so-called hot spot in the enclosure.
- Outlet temp.:** The temperature measured with an external temperature sensor at the cold air outlet from the cooling unit.

Control mode "external sensor"

Please observe the following when selecting the sensor position: The sensor must **not**

- be influenced directly by the cold air expelled from the cooling unit,
- be influenced by external heat sources or heat radiation,
- be exposed to humidity,
- have its connection cable laid in the vicinity of AC cables,
- be exposed to different temperature levels within the first 10 cm of the connection cable.

The sensor **must**

- be located within the effective range of the cooling unit,
- be surrounded by adequate moving air which has blended well with the air expelled by the cooling unit,
- be at an adequate distance from solid and liquid substances.

7 Operation

EN

Control mode "outlet temperature"

- Attach the temperature sensor in front of the cold air outlet from the cooling unit, in the centre (fig. 43).

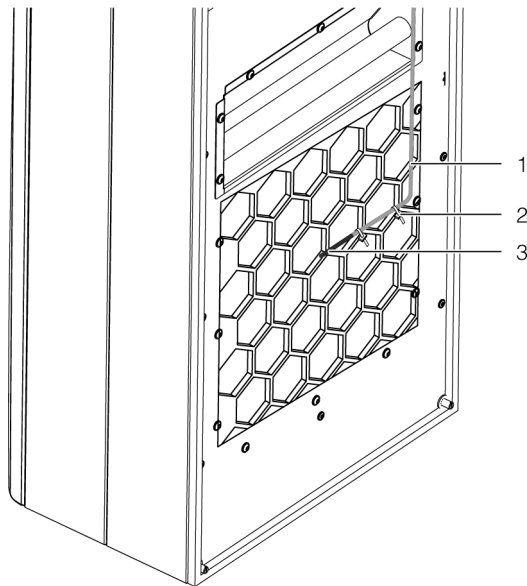

Fig. 43: Temperature sensor in front of cold air outlet (example illustration)

Key

- 1 Sensor cable
- 2 Cable ties (2x)
- 3 Sensor element



Note:
The sensor element must not be in contact with the enclosure.



Note:
To ensure the accuracy of the outlet temperature, at least 50% of the total cooling output should be installed as heat loss. The output can be taken from the characteristic curve for this unit.

Selecting a control mode

- Click on the "Control mode" symbol.
The setpoint for the currently set control mode is displayed.
- Choose your preferred control mode by selecting it from the display:

Symbol	Parameter	Setpoint	Factory setting
	Internal temperature	20 °C (68 °F) ... 50 °C (122 °F)	35 °C (95 °F)
	External sensor		
	Outlet temperature	18 °C (64 °F) ... 28 °C (82 °F)	24 °C (75 °F)

Tab. 13: "Control mode" zone

The corresponding symbol for the chosen control mode is likewise displayed on the overview page.



Note:
The external temperature sensor is available as accessory from Rittal (see section 13 "Accessories").

- Change the setpoint using the "Up" and "Down" arrows or select the required temperature directly.
- Confirm your entry with "OK".

Alarm threshold

This limit is used for an alarm message. The set value must therefore be above the actual setpoint to which the cooling unit has been set.

For example:

- Setpoint: 35 °C (95 °F)
- Alarm limit min.: 38 °C (100 °F)
- Alarm limit max.: 50 °C (122 °F)

Symbol	Parameter	Alarm limit	Factory setting
	Internal temperature	Setpoint + 3 °C (5 °F) ... Setpoint + 15 °C (27 °F)	Setpoint + 5 °C (9 °F)
	External sensor		
	Outlet temperature	Setpoint + 12 °C (21 °F) ... Setpoint + 24 °C (40 °F)	Setpoint + 14 °C (25 °F)

Tab. 14: Alarm limit

- Click on the "Alarm limit" symbol.
- Change the setpoint using the "Up" and "Down" arrows or select the required temperature directly.
- Confirm your entry with "OK".

**Note:**

In "external sensor" and "outlet temperature" control mode, the cooling unit additionally monitors the temperature of the air as it is drawn in. If the set alarm limit seems likely to be exceeded (e.g. due to a rise in heat loss), the cooling output is increased for the duration of the threatened overtemperature, and the setpoint is undercut.

The absolute temperature at which the "Overtemperature" alarm message is output is therefore calculated as follows:

– Limit temperature = Setpoint + alarm threshold

Example of "outlet temperature" control mode:

- Setpoint: 24 °C/75 °F
- Alarm limit (difference): 14 °C/25 °F
- Limit temperature: 38 °C/100 °F

Current situation:

- Temperature of air intake: 37 °C/98.6 °F (< alarm limit)
- Temperature of expelled air: 24 °C/75.2 °F (= setpoint)

If the alarm limit is exceeded:



- Temperature of air intake: 39 °C/102.2 °F (> alarm limit)
- Temperature of expelled air: 22 °C/71.6 °F (< setpoint)

If the alarm limit is subsequently undercut due to an increase in the cooling output:

- Temperature of air intake: 37 °C/98.6 °F (< alarm limit)
- Temperature of expelled air: 24 °C/75.2 °F (= setpoint)

7.4.2 Network

- Click on the "Network" symbol to display a list of lower-level screen pages.



Symbol	Parameter
	Network on/off
	Network info

Tab. 15: "Network" zone

Network on/off

Here, you can activate / deactivate data communication to the IoT interface. Data communication is activated by default.

- Click on the "Network on/off" symbol.
- Select your preferred setting by selecting it from the display.
- Confirm your entry with "OK".



Symbol	Parameter
	Network off
	Network on

Tab. 16: Data communication settings

Network info

Get IP information about how the IoT interface is incorporated into the network.

- Click on the "Network info" symbol to display a list of lower-level screen pages.

Symbol	Parameter
	IPv4
	IPv6

Tab. 17: Select the protocol version

IPv4

- Click on the "IPv4" symbol.
A list of general information about the IPv4 settings will be displayed.
- Page through the list using the "Up" and "Down" arrows.

Parameter	Setting
DHCP	off/on
IP address	xxx.xxx.xxx.xxx
Network mask	xxx.xxx.xxx.xxx
Router address	xxx.xxx.xxx.xxx

Tab. 18: IPv4 settings

IPv6

- Click on the "IPv6" symbol.
A list of general information about the IPv6 settings will be displayed.
- Page through the list using the "Up" and "Down" arrows.
- Click on the desired entries to display the IPv6 addresses.

Parameter	Setting
DHCP	off/on

Tab. 19: IPv6 settings



Parameter	Setting
IP address 1	...
IP address 2	...
Auto address	...
Link-local addr.	...

Tab. 19: IPv6 settings

7.4.3 Alarm relays

There are two floating relay outputs in the connection box on the rear of the unit, which may be used to output system messages from the cooling unit to an external signal source (see section 5.4.3 "Connect the alarm relays"). The relay outputs may be configured here.

- Click on the "Alarm relay" symbol to display a list of lower-level screen pages.

Symbol	Parameter
	Switch NO/NC Switch the alarm relay as a normally closed or normally open contact.
	Function list Allocation of a function to the respective alarm relay.

Tab. 20: "Alarm relay" zone





Note:

For the factory setting of alarm relay allocation see section 7.6 "List of system messages" (Tab. 23).

Switch NO/NC

The switch logic of the relay output, i.e. whether it is to be used as a normally closed or normally open contact, may be set here.

- Click on the "Switch NO/NC" symbol.
- Choose your preferred switch logic by selecting it from the display.
- Confirm your entry with "OK".

Symbol	Parameters
	Normally open Switch the alarm relay as a normally open contact.
	Normally closed Switch the alarm relay as a normally closed contact.

Tab. 21: Switch logic of the alarm relay





Note:

The factory setting of the relay outputs in their de-energised state is NO (Normally Open).

List of functions

This is where you specify which error messages should lead to switching of the respective relay output.

- Click on the "Relay 1" or "Relay 2" symbol, and select the alarm relay to which you wish to assign a function.
- From the list of errors, select the function which should cause the previously selected relay output to switch.
- If applicable, assign further functions to the relay output, and the output will then be switch if **at least one** of the assigned functions leads to an error message.
- Confirm your entry with "OK".
- If applicable, configure the other relay output with other functions.

Symbol	Parameter
	Assign relay 1
	Assign relay 2

Tab. 22: List of functions

7.4.4 Language settings

All displays on the unit are available in 21 different languages.

- Click on the "Display language" symbol.
- Page through to the required language using the "Up" and "Down" arrows.
- Confirm the chosen language with "OK".

The language will change over immediately, and all menu displays will appear in the chosen language.

7.4.5 Self-test

In the event of a malfunction in the unit which fails to produce an error message, it may be useful to check the key functions of all components with a self-test. You may continue to operate the unit as normal while the self-test is being carried out.

- Click on the "Self-test" symbol.
- Confirm the start of the self-test with "OK".

While the self-test is being carried out, a progress indicator will appear on the display. Once the test is complete, either the message "Unit OK" or "Check error" will be displayed.

- If applicable, use the error list to determine which malfunction applies.

7.5 System messages

We distinguish between three different types of system messages on the unit:

- Malfunctions 
- Errors 
- Servicing 

If a corresponding message applies, the "System messages" symbol is displayed in the menu bar (fig. 41, item 13). A list of all possible system messages may be found in section 7.6 "List of system messages".

■ Click on the "System messages" symbol.

A list of all active system messages will be displayed. The individual messages are arranged in ascending order as they occur according to the above three categories.

If an error message can only be resolved by the Rittal Service team, the "Service" symbol  will additionally appear after the error message.

■ In such cases, please contact Rittal Service (see section 14 "Customer service addresses").

7.5.1 Occurrence of a malfunction

In the event of a malfunction, the start screen will be superimposed with an error message.

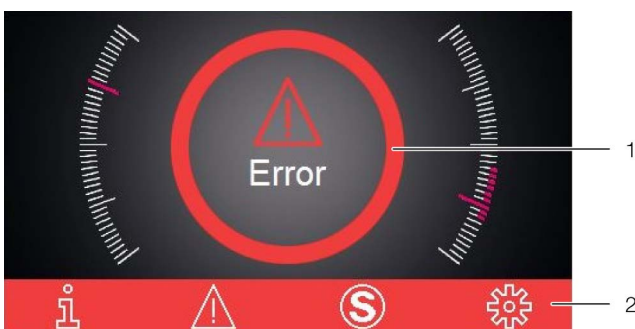

Fig. 44: Screen in the event of a malfunction

Key

- 1 Superimposed
- 2 Menu bar in red

The start screen is superimposed with a message in the following two cases:

1. There is a malfunction on the unit itself.
2. The enclosure door is open and a connected door contact is emitting a corresponding message.

If the malfunctions cannot be resolved by the operator himself, the Service symbol will additionally be displayed (fig. 41, item 14).

■ Contact the Rittal Service team if you are unable to resolve the malfunction yourself (see section 14 "Customer service addresses").

7.5.2 Display in case of errors

If errors have occurred or servicing is required, the "System messages" symbol will appear in the menu bar (see section 7.5 "System messages").

Most system messages are reset automatically once the fault has been resolved.

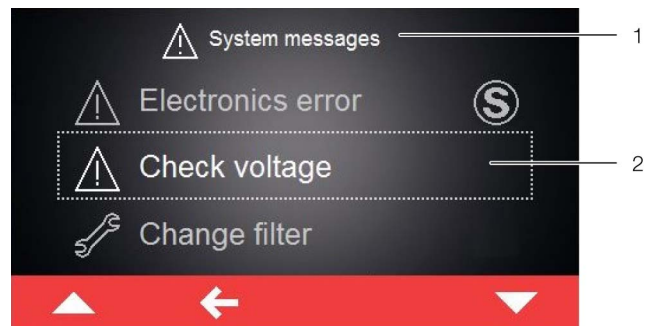

Fig. 45: Screen showing error messages

Key

- 1 "Errors" menu
- 2 Error message

If an error message applies that cannot be resolved by the operator himself and which is not reset automatically, the "Service" symbol will appear after the error message and in the control bar next to the symbol for system messages (fig. 46, item 2).

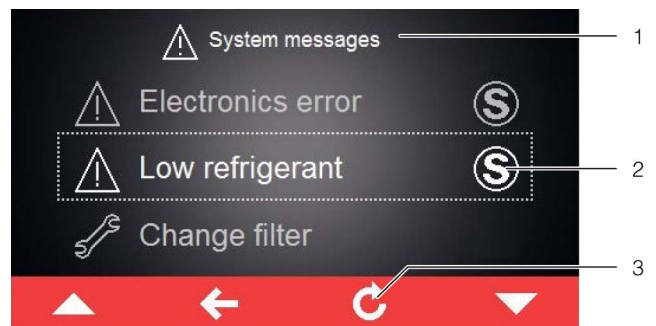

Fig. 46: Screen showing error messages

Key

- 1 "Errors" menu
- 2 Error message
- 3 "Return" button

■ Contact Rittal Service (see section 14 "Customer service addresses").

■ Acknowledge the error message by pressing the "Return" button.

7.5.3 Parallel device control

The IoT interface (Model No. SK 3124300, see section 13 "Accessories") supports parallel activation and deactivation of up to two cooling units. Further information can be found in the "Additional instructions" document for the IoT interface. This document is available for downloading on the Rittal website.











7 Operation

EN













7.6 List of system messages

The applicable error messages are displayed with the corresponding symbol in the Errors list (see section 7.5 "System messages"). Extended information for resolving individual faults may be found in this section.

Contact details for the Rittal Service team can be found in section 14 "Customer service addresses".

System message	Alarm relay output (factory setting)	Troubleshooting measures/solutions
Door open 	–	Please close the enclosure door and check the door contact switch. The error message will terminate automatically approximately 30 seconds after it has been resolved.
Int.temp too high 	–	The measured interior temperature exceeds the set alarm limit for your cooling unit. Please check any maintenance and error messages, and check the rating of your cooling unit. For any further questions, please contact Rittal Service directly.
Clean condenser 	–	The condenser in your cooling unit is dirty. Please remove the top louvred grille and clean the heat exchanger, e.g. using compressed air. The error message will terminate automatically approximately 30 seconds after it has been resolved.
Ext. air circuit 	1	The air inlet or outlet in the external circuit is blocked. Please remove the blockage and ensure that minimum distances from the air inlet or outlet are observed.
Int. air circuit 	–	The air inlet or outlet in the internal circuit is blocked. Please remove the blockage and ensure that minimum distances from the air inlet or outlet to components inside the enclosure are observed.
Exp. valve defect 	–	A malfunction has been detected in the electronic expansion valve. Please contact your Rittal Service.
Ambient temperature outside 	–	Your cooling unit is being operated outside of the admissible ambient temperature. Please ensure that the ambient temperature does not go above or below the admissible range (-30 °C...+60 °C/ -22 °F...+140 °F).
Low refrigerant 	2	Your cooling unit is reporting a lack of cooling in the active refrigerant cycle. Please contact the Rittal Service team immediately. The system message will need to be acknowledged manually once the cause has been rectified.
Condensate alert 	1	Please check whether the condensate water drain of your cooling unit is blocked, and remove the blockage. If you are unable to resolve the fault, please contact your Rittal Service team.
Int. fan alarm 1 	1	The fan in the internal circuit of your cooling unit is blocked. Please check if you can see a blockage and remove it. If no blockage is visible, please replace the fan in the internal circuit. The required spare part may be ordered directly from Rittal using the "Rittal Scan & Service" app. Please use the contact form "Generate service order".



Tab. 23: Error messages

System message	Alarm relay output (factory setting)	Troubleshooting measures/solutions
Int. fan alarm 2 	1	The fan in the internal circuit of your cooling unit is defective. Please replace the fan in the internal circuit. The required spare part may be ordered directly from Rittal using the "Rittal Scan & Service" app. Please use the contact form "Generate malfunction report".
Ext. fan alarm 1 	1	The fan in the external circuit of your cooling unit is blocked. Please check if you can see a blockage and remove it. If no blockage is visible, please replace the fan in the external circuit. The required spare part may be ordered directly from Rittal using the "Rittal Scan & Service" app. Please use the contact form "Generate service order".
Ext. fan alarm 2 	1	The fan in the external circuit of your cooling unit is defective. Please replace the fan in the external circuit. The required spare part may be ordered directly from Rittal using the "Rittal Scan & Service" app. Please use the contact form "Prepare malfunction report".
Inverter cooler 	–	The cooling body of the inverter in your cooling unit is dirty. Please remove the filter grille and the cover at the front and clean the cooling body, e.g. using compressed air. The error message will terminate automatically approximately 30 seconds after it has been resolved.
Compressor defect 	2	The compressor in your cooling unit is reporting a malfunction. Please contact the Rittal Service team immediately.
Sensor xx defect 	1	Sensor xx in your cooling unit is reporting a sensor failure. Please contact the Rittal Service team.
Ext.sens. missing 	1	The external sensor is not connected or has a malfunction. Please check the connection or select another control mode.
Check voltage 	1	You are operating your cooling unit outside of the admissible voltage ranges. Please check the power supply to the cooling unit and observe the specifications on the rating plate. With a three-phase infeed, please also check that all three phases are correctly connected.
Electronics error 	2	The electronics in your cooling unit are reporting an electronic fault. Please contact the Rittal Service team.
Check parameters 	–	Due to an error, the cooling unit has been reset to the factory defaults. Please check the current messages or contact your Rittal Service team.
Inverter fault 	2	The inverter in your cooling unit is reporting a malfunction. Please contact the Rittal Service team.
Alarm mode active 	–	Due to a previous error your cooling unit is only operating with a performance of 50%. Please remedy this error and/or contact your Rittal Service team.

Tab. 23: Error messages

7 Operation

EN

System message	Alarm relay output (factory setting)	Troubleshooting measures/solutions
Compressor phase 	2	The compressor in your cooling unit is reporting a malfunction. Please contact your Rittal Service team.
Overload 	1	Please check the rating of your cooling unit. For any further questions, please contact your Rittal Service team directly.
Alarm act.cooling 	–	The active cooling function of your unit is defective. Please contact the Rittal Service team immediately, and/or check the rating of your cooling unit.

Tab. 23: Error messages

8 Inspection and maintenance

8.1 Safety instructions for maintenance work

The unit must be opened in order to carry out maintenance work. There is a risk of injury from electric shock.

- Switch off the power supply before carrying out maintenance work.
- Secure the power supply to prevent it being switched back on accidentally.
- Disconnect the electrical connection cable of the cooling unit from the power supply at the connection box.
- Wait at least five minutes before handling the unit. Only then will the capacitors built into the unit have discharged themselves.
- When handling the enclosure, be aware of any exposed power sources, where applicable.
- If possible, disconnect the entire enclosure from the power.
 - If assistance of other persons is required for maintenance and repair work, a person trained in handling flammable refrigerants should supervise the work at all times.

There is also a risk of injury from sharp edges, such as the louvres of the heat exchanger.

- Wear cut-resistant gloves for all maintenance work. After removing the cover, there is a risk of burn injuries from hot surfaces on the components inside the unit.
- Before carrying out any work on the interior of the unit, allow it to cool down for at least ten minutes.

8.2 Notes on the refrigerant circuit

The cooling unit is filled with the amount of refrigerant required at the factory, checked for leaks, and subjected to a functional test run. The refrigerant circuit is designed in the form of a maintenance-free, hermetically sealed system. For this reason, the operator should not carry out any maintenance work on the refrigerant circuit.



Caution!

Maintenance tasks on the refrigerant circuit must only be undertaken by a qualified refrigeration specialist.

8.3 Maintenance work on the cooling unit

If there is visible dirt present, the components in the outer air circuit should be cleaned using a vacuum cleaner or compressed air.



Note:

The maintenance intervals given below depend to a large extent on the level of contamination in the ambient air. For heavily contaminated air, the maintenance intervals will be reduced accordingly.

- Clean the cooling unit inside and out at least every 5,000-8,000 operating hours as described in section 8.4 "Compressed air cleaning".
- Any stubborn, oily stains may additionally be removed using a non-flammable detergent, such as degreaser.



Caution!

Never use flammable liquids for cleaning the unit.

The installed maintenance-free fans are mounted on ball bearings, protected against moisture and dust, and fitted with a temperature monitor.

- Rittal recommends that the cooling unit fans should be checked e.g. for unusual running noises after around 40,000 operating hours.

8.4 Compressed air cleaning

8.4.1 Removing the cover

- Using the special TX25 torx wrench from the dispatch bag, loosen the three assembly screws underneath the cover and pull them off downwards.

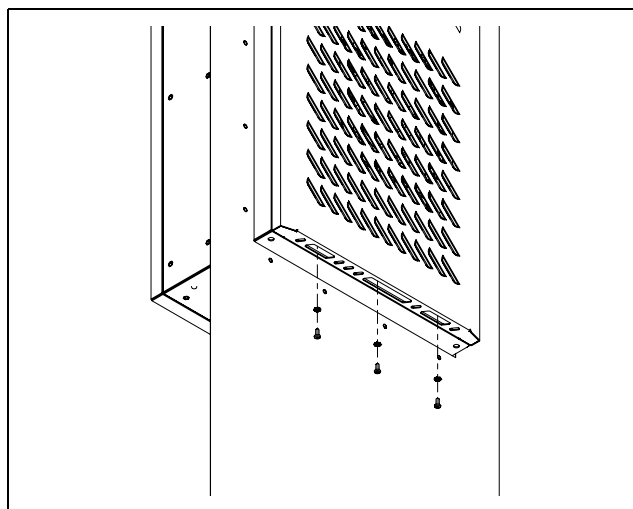

Fig. 47: Loosen the assembly screws

- Raise the cover slightly and gently pull it forwards away from the enclosure.

8 Inspection and maintenance

EN

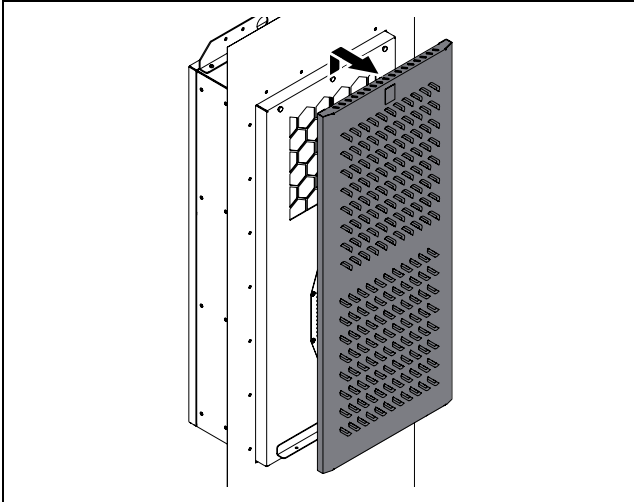

Fig. 48: Raise the cover

- Then swing the cover gently to the side.

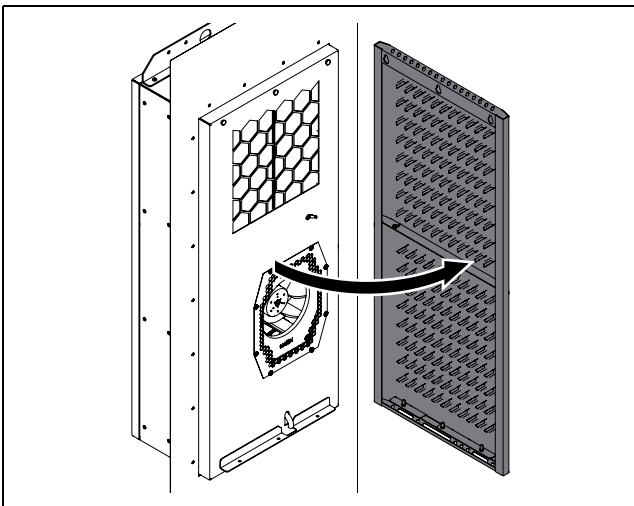

Fig. 49: Swing the cover sideways

- The PE conductor connection between the cover and the chassis is located on the right-hand side, around half-way up.
- Disconnect the flat-pin connector of the internal PE conductor, preferably on the enclosure, then remove the cover completely from the unit.

8.4.2 Cleaning the components with compressed air

After removing the cover from the unit, you will be able to access the components in the outer circuit, particularly the condenser, the condenser fan and the compressor chamber.

- Wear cut-resistant gloves when cleaning with compressed air, so as to avoid injuries caused by sharp edges inside the unit.
- When cleaning the components with compressed air, blow dirt sideways out of the cooling unit.
- Alternatively, use a suitable vacuum cleaner to clean all components.

8.4.3 Re-fitting the cover

Once cleaning work is complete, re-fit the cover onto the cooling unit.

- Re-fit the cover onto the enclosure in the reverse order.
- Please note, it is important to ensure that the PE conductor connecting the cover to the enclosure is connected at both ends.

9 Storage and disposal



Note:

When storing the cooling unit, please observe the temperature range given in the technical specifications.

- Store the cooling unit in the appropriate position for transport.

The closed refrigerant circuit contains refrigerant and oil which must be properly disposed of for the sake of the environment. Facilities for disposal are available at the Rittal plant or a specialist company. Give us a call (see section 14 "Customer service addresses").

10 Technical specifications

EN

10 Technical specifications

Pos.	Technical specifications		SK 3485330	SK 3486330	SK 3487330	SK 3488340	SK 3489340
	General specifications						
	Model No.		SK 3485330	SK 3486330	SK 3487330	SK 3488340	SK 3489340
	Dimensions (width x height x depth) [mm]		415 x 990 x 280	465 x 1640 x 260		465 x 1640 x 360	
	Cooling output to EN 14511 [W]						
7	Total cooling output Pc	L35 L35	1500	2000	2500	3700	4550
		L35 L50	950	1290	1600	2660	2850
	Sensible cooling capacity Ps	L35 L35	1500	2000	2500	3680	4390
	Power consumption Pel	L35 L35	650	700	1080	1650	2350
		L35 L50	550	680	1030	1570	1700
	Energy efficiency ratio (EER)	L35 L35	2.31	2.86	2.31	2.24	1.94
		L35 L50	1.73	1.90	1.55	1.69	1.68
	Electrical specifications						
1	Rated voltage [V, ~], tolerance		110 ... 240, 1, +10%/-10%			-	
			380 ... 480, 3, +5%/-15%				
2	Rated frequency [Hz]		50/60				
	Rated insulation voltage Ui [V]		500				
	Rated impulse withstand voltage Uimp [kV]		2.5				
3	Rated output [W]		700	850	1050	1570	2350
4	Rating of over current protective device [A]		≥15				
5	Minimum circuit ampacity [A]		15				
6	Input ampere range [A]		6.9@110 V – 1.2@380 V	7.3@110 V – 1.3@380 V	11@110 V – 1.8@380 V	2.5@380 V – 1.9@480 V	3.9@380 V – 3.1@480 V
	Pre-fuse T [A]	EN 61439	≥16				
		UL 508A	≥15				
	Pre-fuse type		CCMR				
	Alternatively one of the following pre-fuses		SK 3235600: miniature circuit-breaker 5SY4116-8 (IEC)			-	
			SK 3235610: circuit-breaker 3RV2021-4AA10-0RT0 (IEC) (SCCR = 55 kA)				
			SK 3235620: circuit-breaker 3RV2711-4AD10-0RT0 (UL und CSA) (SCCR = 65kA)				
	SCCR [kA]		5				
	Cable cross-section [mm ²]	EN 61439	1.5				
		UL 508A	≥2.1 or ≤14 AWG				
	Overtoltage category		III				
	Level of contamination		III				

Tab. 24: Technical specifications Blue e+ Outdoor

10 Technical specifications

EN

Pos.	Technical specifications	SK 3485330	SK 3486330	SK 3487330	SK 3488340	SK 3489340
Protection category with the unit externally mounted						
18	IP protection category with mounting frame				56	
18	IP protection category without mounting frame				54	
20	UL type rating with mounting frame				12, 3R and 4	
20	UL type rating without mounting frame				12 and 4	
Electromagnetic compatibility						
	Immunity to interference				For industrial areas to EN 61000-6-2	
	Emitted interference				For residential, business and commercial areas and small companies to EN 61000-6-3	
Refrigerant circuit						
17	Admissible pressure (PS) HP/LP [MPa]				2.4	
11	Operating temperature range [°C/°F]				-30...+60/-22...+140	
	Heat pipe active mode [°C/°F]				-30...< Setpoint/-22...< Setpoint	
	Refrigerant cycle active mode [°C/°F]				+3...+60/+37...+140	
	Setting range set value [°C/°F]				+20...+50/+68...+122	
14	Refrigerant identification				R1234yf (2,3,3,3-Tetrafluoropropene (C3H2F4))	
12	Refrigerant filling mass compression system [g]	475		655		1040
13	Refrigerant filling mass heat pipe system [g]	290		450		720
16	GWP				0.5	
17	CO ₂ e [t]	0.00		0.00		0.00
Other						
	Weight [kg]	36		56.8		72.8
	Storage temperature range [°C/°F]				-40...+70/-40...+158	
	Humidity [%]				5...95, non-condensing	
	Noise pressure level Lp [dB(A)]	<67		<70		<71
	Material				Aluminium (AlMg3)	
	Colour				RAL 7035	
Approvals: See product page on the Rittal website						

Tab. 24: Technical specifications Blue e+ Outdoor

10 Technical specifications

EN

Country of origin: <input type="text"/>		Rittal Gmbh & Co.KG Auf dem Stuetzelberg 35745 Herborn		27	
SK *** <input type="text"/>		REV. ** <input type="text"/>		QR-Code <input type="text"/>	
S/N: **** <input type="text"/> Client spec: ***** <input type="text"/>					
Enclosure Cooling Unit Schaltschrank-Kühlgerät Climatiseur pour armoires electriques 空调器 (控制柜冷却装置)					
Rated voltage/Bemessungsspannung/额定工作电压	<input type="text" value="1"/>				
Rated frequency/Frequenz/频率	<input type="text" value="2"/>				
Rated power input/Bemessungsleistung/额定功率输入	<input type="text" value="3"/>				
Rating of over current protective device (fuse or circuit breaker as defined in manual) / 过电流保护装置额定值 (按照产品手册中定义的熔断器或断路器)	<input type="text" value="4"/>				
Minimum circuit ampacity / 最小电流	<input type="text" value="5"/>				
Input ampere range / 输入电流范围	<input type="text" value="6"/>				
Rated input current of the inverter/ 变频器额定输入电流	<input type="text" value="6"/>				
Total cooling capacity DIN EN 14511 Gesamtkühlleistung DIN EN 14511/有效冷却功率	<input type="text" value="7"/>				
Temperature range/Betriebstemperaturbereich 温度范围	<input type="text" value="11"/>				
Refrigerant charge/Kältemittel-Füllmenge/制冷剂容量	<input type="text" value="12"/>				
Heat pipe / Kältemittelkreislauf /热管	<input type="text" value="13"/>				
Refrigerant ID/Kältemittel Identification/制冷剂型号	<input type="text" value="14"/>				
GWP	<input type="text" value="15"/>				
CO2e	<input type="text" value="16"/>				
Allowable pressure(PS)/Zulässiger Druck(PS)/ 允许压力	<input type="text" value="17"/>				
IP-Code/Schutzart EN 60529/ IP等级	<input type="text" value="18"/>				
Internal circuit/Innenkreislauf/内循环电路防护等级	<input type="text" value="19"/>				
External circuit/Außenkreislauf/外循环电路防护等级	<input type="text" value="20"/>				
Environmental Type Rating	<input type="text" value="20"/>				
Manufacturing date/ Produktionsdatum/生产日期	<input type="text" value="35"/>				
Hermetical sealed/Hermetisch geschlossen Leakage tested EN-378-2/Dichtheit geprüft					
Rittal Service International: www.rittal.com/service					
		<input type="text" value="42"/>		<input type="text" value="41"/>	
				<input type="text" value="38"/>	
				<input type="text" value="39"/>	
<input type="text" value="20"/>	<input type="text" value="29"/>	<input type="text" value="35+36"/>	<input type="text" value="28"/>	<input type="text" value="37"/>	
<input type="text" value="21"/>	<input type="text" value="32"/>				
	<input type="text" value="23+24"/>	<input type="text" value="33+34"/>			
<input type="text" value="22"/>	<input type="text" value="25"/>	<input type="text" value="30"/>			
	<input type="text" value="26"/>	<input type="text" value="31"/>			
Appliance should not be accessible to the general public.					
Rittal Limited Braithwell Way Hellaby Rotherham S66 8QY, UK					



Note:
The illustration shows the rating plate for a "Blue e+" device as an example.

11 List of spare parts

You can find spare parts on the relevant Rittal website under the relevant Model No.



Note:

The components used are Rittal-specific components. We recommend using only original Rittal spare parts to ensure the guaranteed unit properties (output).

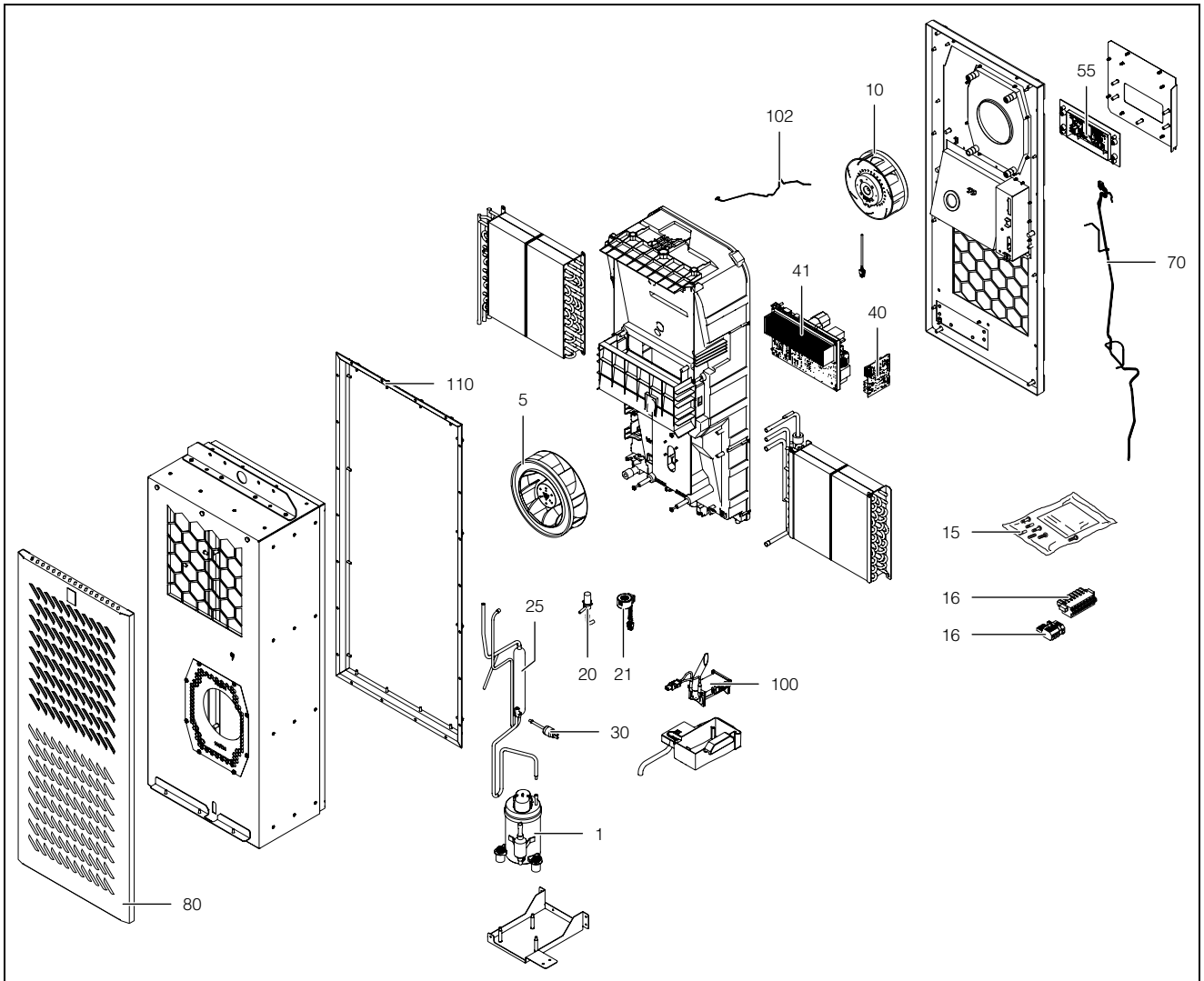

Fig. 50: Spare parts (example illustration)

Key

- | | | | |
|-----|---|-----|----------------|
| 1 | Compressor | 102 | Display cable |
| 5 | Condenser fan | 110 | Mounting frame |
| 10 | Evaporator coil fan | | |
| 15 | Accessories bag | | |
| 16 | Connector | | |
| 20 | Expansion valve | | |
| 21 | Coil for expansion valve | | |
| 25 | Filter dryer | | |
| 30 | PSA ^H pressure-operated switch as pressostat | | |
| 40 | I/O-board | | |
| 41 | Inverter | | |
| 55 | Display/controller | | |
| 70 | Temperature sensor kit | | |
| 80 | Cover | | |
| 100 | Condensate water evaporator | | |

12 Drawings

12.1 Mounting cut-outs on single-walled enclosure panels without a mounting frame

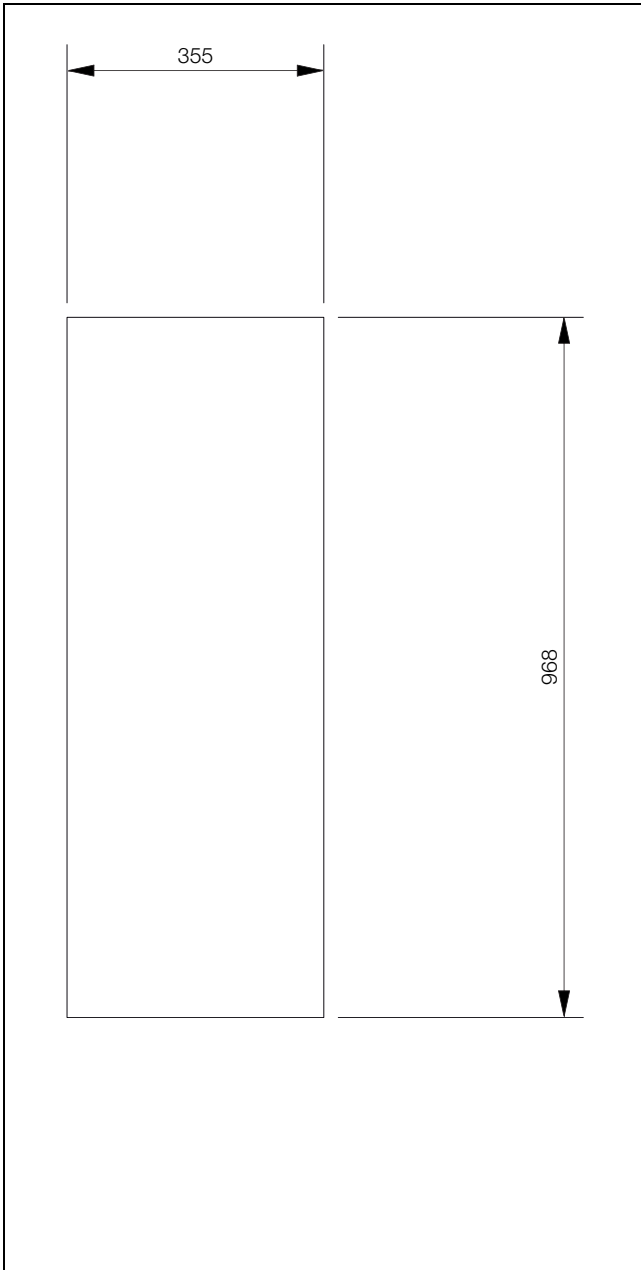

Fig. 51: SK 3485330

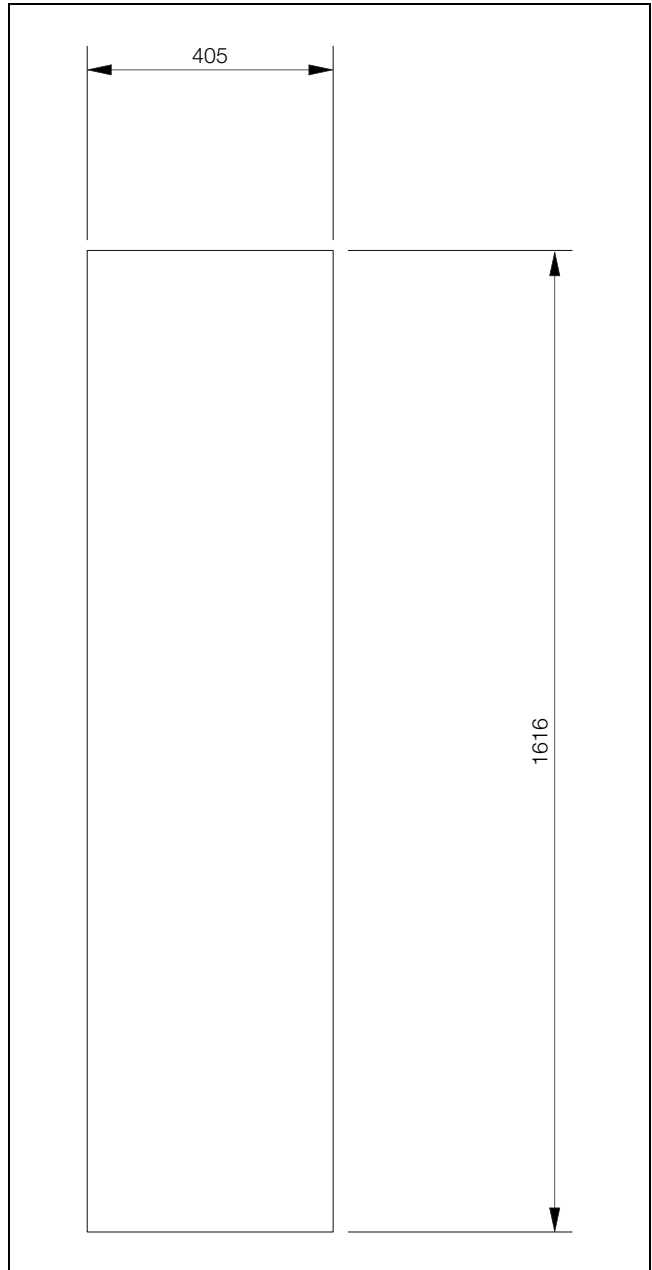
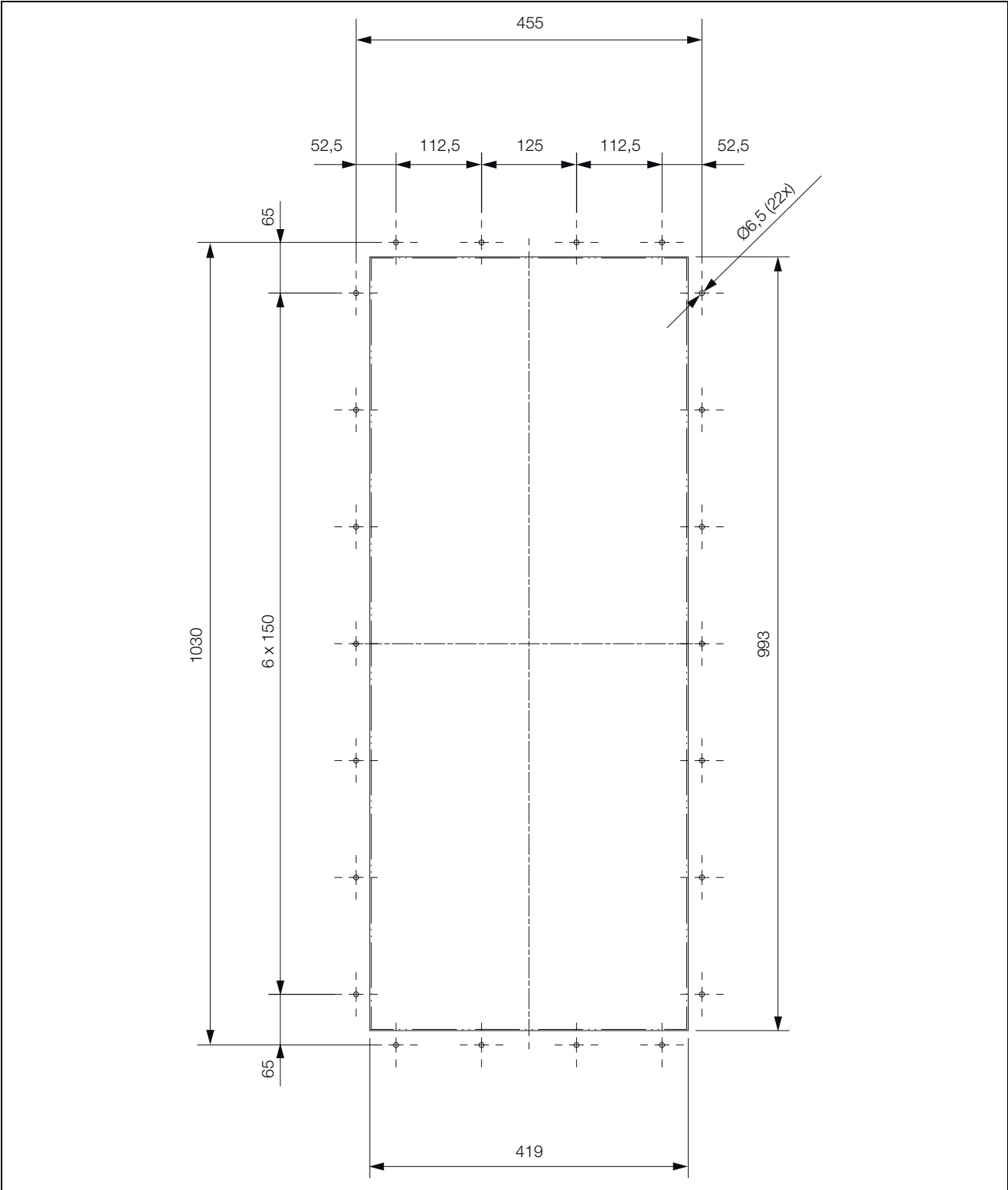

Fig. 52: SK 3486330, SK 3487330, SK 3488340, SK 3489340

12.2 Mounting on single- and twin-walled enclosure panels with a mounting frame

12.2.1 SK 3485330

EN



12 Drawings

EN

12.2.2 SK 3486330, SK 3487330, SK 3488340, SK 3489340

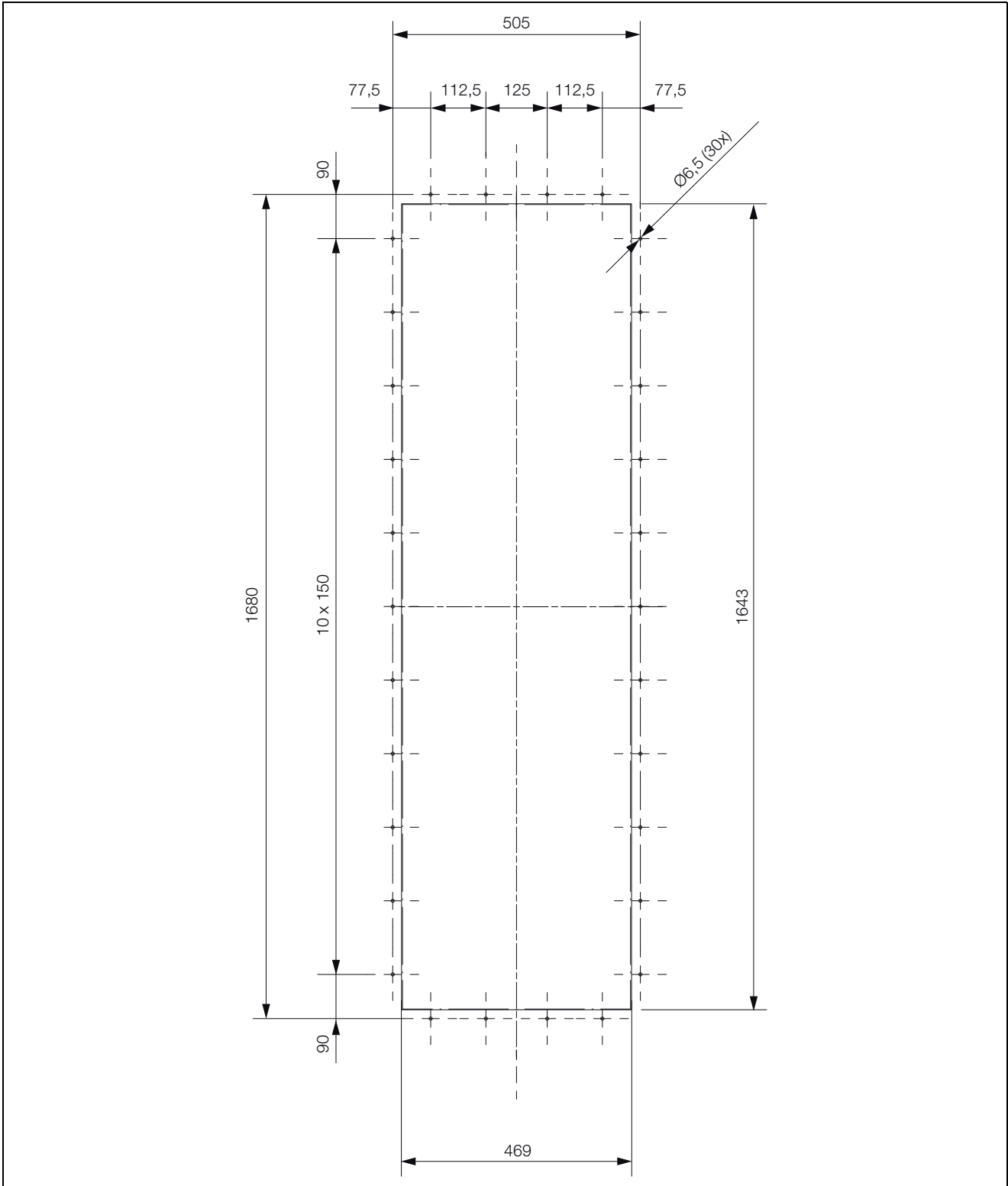

12.3 Dimensions and installation depths

12.3.1 External mounting, partial internal mounting and full internal mounting (SK 3485330)

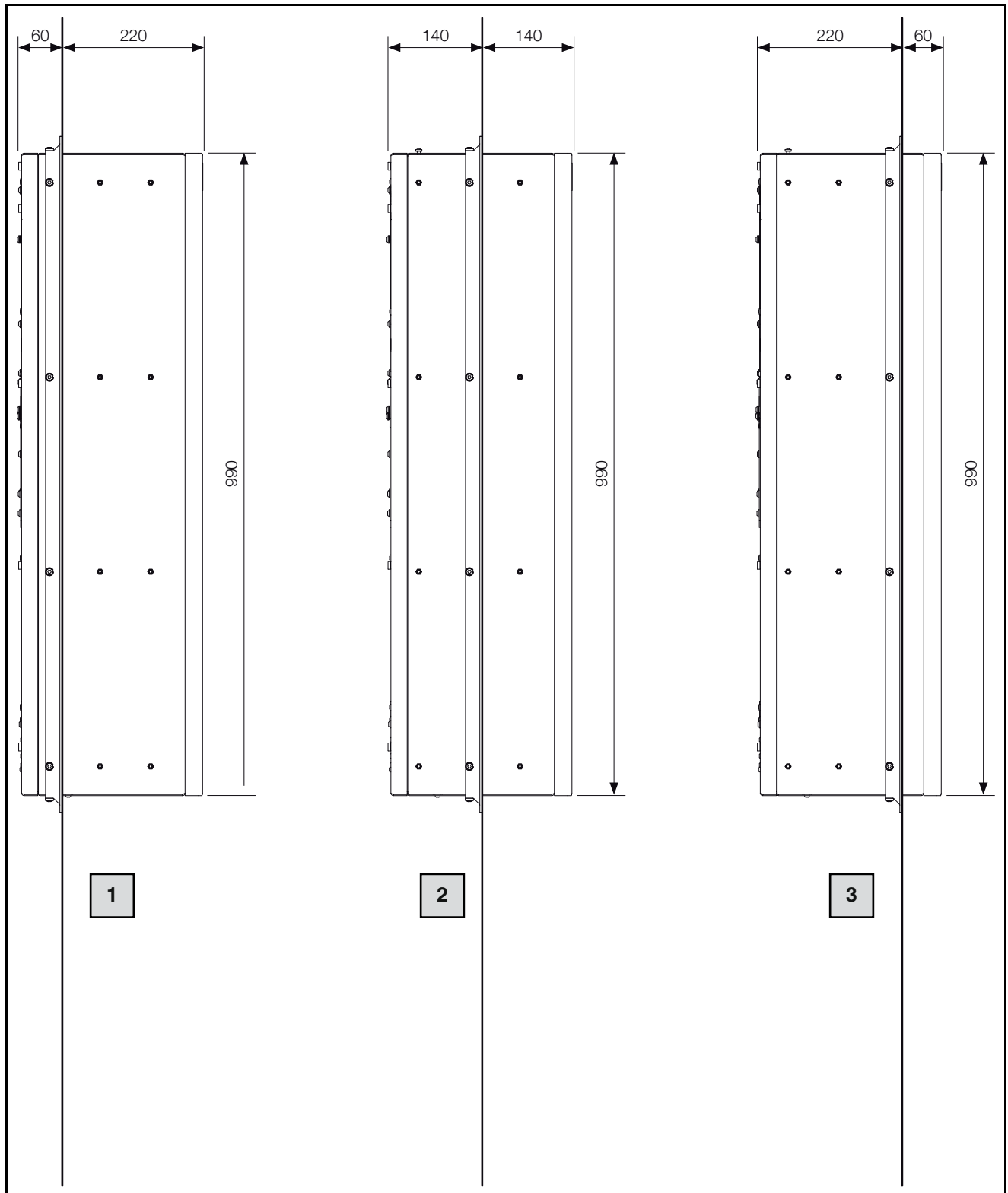

Fig. 53: Dimensions

Key

- 1 External mounting
- 2 Partial internal mounting
- 3 Full internal mounting

12 Drawings

EN

12.3.2 External mounting, partial internal mounting and full internal mounting (SK 3486330 and SK 3487330)

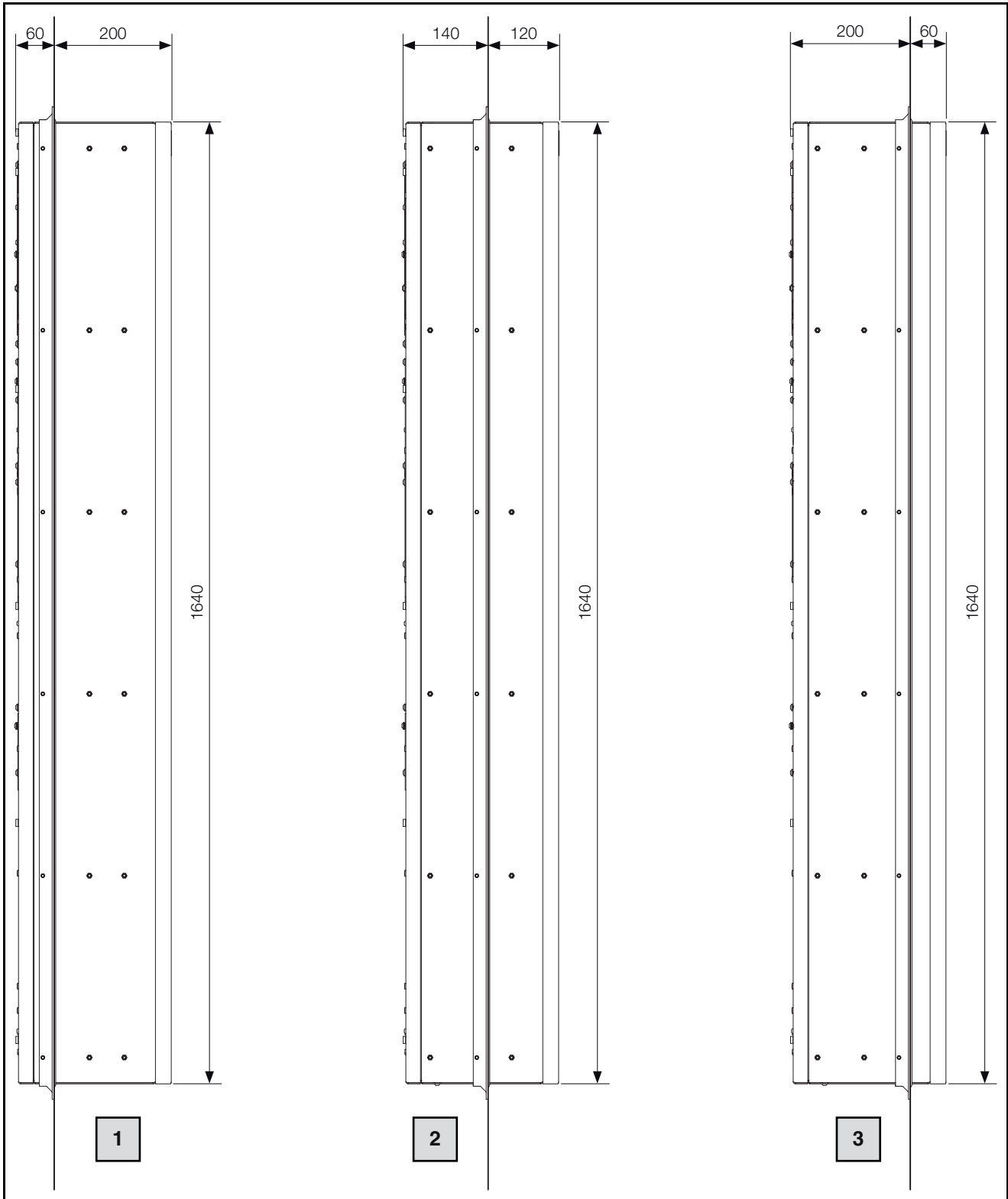

Fig. 54: Dimensions

Key

- 1 External mounting
- 2 Partial internal mounting
- 3 Full internal mounting

12.3.3 External mounting, partial internal mounting and full internal mounting (SK 3488340 and SK 3489340)

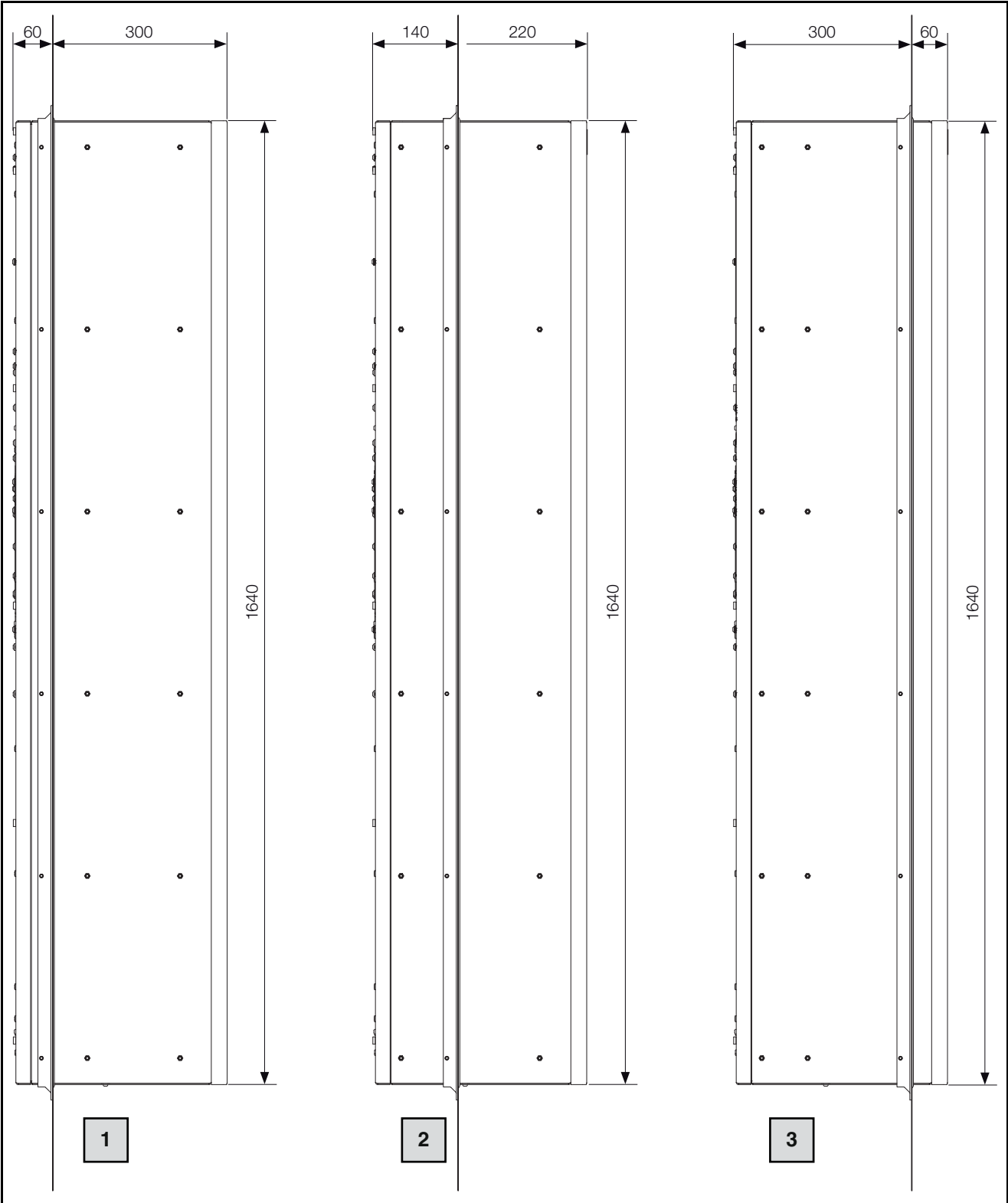

Fig. 55: Dimensions

Key

- 1 External mounting
- 2 Partial internal mounting
- 3 Full internal mounting

13 Accessories

EN

13 Accessories

As well as the accessories listed below, details of our full range of accessories can be found on the Rittal website.

Item	Model No.
Door limit switch	4127010
Condensate water hose	3301612
External temperature sensor	3124400
IoT Interface	3124300
"Rittal Scan & Service" app	   

Tab. 25: List of accessories

14 Customer service addresses

Contact details can be found on the Rittal website at:

– <https://www.rittal.com/rittal-locations>

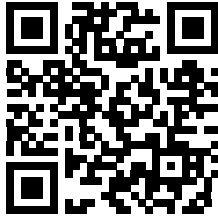

15 Compact service information

EN

15 Compact service information

Step	See	OK/comment
Assembly and connection		
– Installation site requirements taken into account	Section 5.2	
Assembly instructions		
– Observe the relevant assembly instructions	Section 5.3.1	
– Condensate water discharge connected	Section 5.3.6	
– Electrical installation (overvoltage protection, door limit switch)	Section 5.4	
Commissioning		
Check the assembly – All attachments checked		
Commissioning – At least 30 minutes after assembly	Section 6	
– Download the "Rittal Scan & Service" app to support commissioning and subsequent operation		
– Commissioning check carried out via "Rittal Scan & Service" app		
Operation		
– Check the device status during operation using the "Rittal Scan & Service" app		
– Read maintenance instructions and warnings or fault messages using the "Rittal Scan & Service" app		

Tab. 26: Quick installation check

For all other service enquiries:

Original spare parts	Maintenance, warranty extensions (up to 5 years), service contracts
<ul style="list-style-type: none"> – Enquire directly via "Rittal Scan & Service" app – http://www.rittal.com 	<ul style="list-style-type: none"> – Enquire directly via "Rittal Scan & Service" app – http://www.rittal.com – Enquire at the relevant national company – http://www.rittal.com/de_de/service_contact/index.asp
Other service contacts worldwide: Rittal International Service HUBs (see section 14 "Customer service addresses")	

Tab. 27: Service contacts worldwide

Rittal – The System.

Faster – better – everywhere.

- Enclosures
- Power Distribution
- Climate Control
- IT Infrastructure
- Software & Services

You can find the contact details of all Rittal companies throughout the world here.



www.rittal.com/contact

RITTAL GmbH & Co. KG
Auf dem Stuetzelberg · 35745 Herborn · Germany
Phone +49 2772 505-0
E-mail: info@rittal.de · www.rittal.com

12.2025 / D-0000-000004361-00-EN

ENCLOSURES

POWER DISTRIBUTION

CLIMATE CONTROL

IT INFRASTRUCTURE

SOFTWARE & SERVICES

FRIEDHELM LOH GROUP

