

Rittal – The System.

Faster – better – everywhere.

▶ LCU DX – Efficient cooling with no loss of space



ENCLOSURES

POWER DISTRIBUTION

CLIMATE CONTROL

IT INFRASTRUCTURE

SOFTWARE & SERVICES

FRIEDHELM LOH GROUP



Rittal – The System.

Faster – better – everywhere.



ENCLOSURES

POWER DISTRIBUTION

CLIMATE CONTROL

FRIEDHELM LOH GROUP

Cooling for network and server enclosures

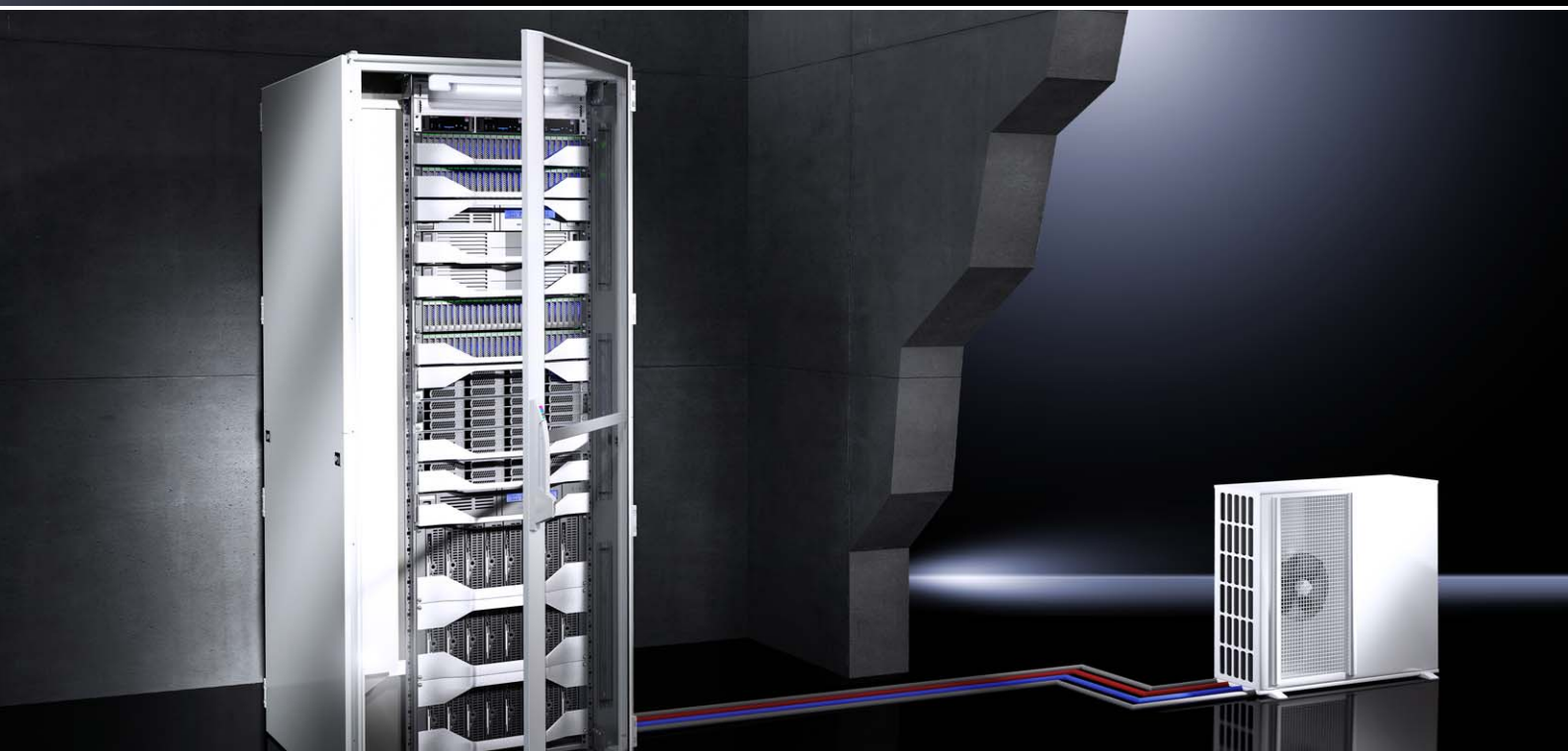

- Space-saving installation of the internal unit between the 482.6 mm (19") level and side panel
- Optimum support of IT-compatible, "front-to-back" air routing
- High level of fail-safeness guaranteed by availability of single and redundant variant
- Cooling of TS IT racks and Micro Data Center
- Refrigerant-based split cooling unit comprised of an internal unit (evaporator coil) and an external unit with integral compressor (inverter-controlled)
- External unit is sited outside the building

IT INFRASTRUCTURE

SOFTWARE & SERVICES



Rittal – The System.

Faster – better – everywhere.



ENCLOSURES

POWER DISTRIBUTION

CLIMATE CONTROL

FRIEDHELM LOH GROUP

Benefits at a glance



- Maximum energy efficiency by cooling the individual rack, rather than the whole room
- Efficient operation thanks to EC fan technology
- Optimum adaptation of the compressor output to the current heat load of the IT rack with inverter control
- Ultimate security with optional alarm forwarding via CMC III
- High availability designed for continuous, 24/7 operation
- Absorbed thermal energy is emitted via the external unit directly to the ambient air
- The internal and external unit are connected with refrigerant, data and supply lines
- Control of the server inlet temperature

IT INFRASTRUCTURE

SOFTWARE & SERVICES



Liquid Cooling Unit



Network/server enclosures TS IT Cat. 34, page 90 Micro Data Center Cat. 34, page 466

Applications:

- Cooling unit for TS IT server enclosures and for Micro Data Center

Benefits:

- Space-saving solution by installing the internal unit in the TS IT server enclosure or the Micro Data Center
- Maximum energy efficiency due to EC fan technology and IT-based control
- Control of the server inlet temperature
- The inverter-controlled compressor adapts the cooling output to the current heat loss inside the enclosure
- Absorbed thermal energy is emitted directly to the ambient air at the (inverter-controlled) external unit's location, without heating up the installation room

Functions:

- The device supports "front to back" air routing typical of IT applications, and regulates the server inlet temperature to the set value

Colour:

- Internal unit: RAL 7035
- External unit: white

Protection category IP to IEC 60 529:

- Internal unit IP 20
- External unit IP X4

Supply includes:

- Internal unit (evaporator coil)
- External unit (inverter-controlled)
- 482.6 mm (19") mounting trim panel with display and control components
- Condensate hose

Note:

- Below the operating limit, fluctuations in the air inlet temperature are possible
- The electrical connection is made on the external unit; the internal unit is supplied by the external unit

Installation in TS IT:

- 482.6 mm (19") levels must be designed as mounting angles and offset in the width by 50 mm off-centre
- The front distance between the 482.6 mm (19") mounting angles and the front edge of the TS frame must be at least 100 mm
- Not suitable for combination with 482.6 mm (19") mounting frame
- Two punched sections with mounting flanges are required for attachment on the inner mounting level
- To separate the hot/cold zones within an enclosure, an air baffle plate for TS IT is required
- A Flex-Block base/plinth is required to route the cable downwards

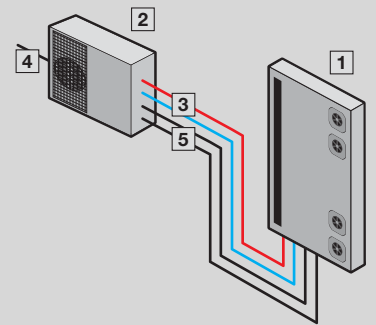

- 1 Internal unit
- 2 External unit
- 3 Refrigerant lines
- 4 Power supply
- 5 Data cable

Further technical information:

Available on the Internet

LCU DX, single

Design	Packs of	LCU DX 3 kW	LCU DX 6.5 kW	Page
Model No.	1 pc(s).	3311.490	3311.492	
For enclosure width mm		800	800	
For enclosure height mm		≥ 1800	≥ 1800	
For enclosure depth mm		≥ 1000	≥ 1000	
External unit, W x H x D mm		810 x 558 x 310	845 x 700 x 320	
Internal unit, W x H x D mm		105 x 1550 x 820	105 x 1550 x 820	
Type of electrical connection		Connection clamp	Connection clamp	
Rated operating voltage V, ~, Hz		230, 1~, 50	230, 1~, 50	
Rated current (max.) A		7	15.9	
Pre-fuse A		16	20	
Duty cycle %		100	100	
Useful cooling output L22 L35 kW		3	6.5	
Cooling medium		R410a	R410a	
Sound pressure level at a distance of 10 m (external unit) dB(A)		40	40	
Operating temperature range (external unit)		-20°C...+45°C	-20°C...+45°C	
Weight as delivered kg		116.0	126.0	
Accessories				
Refrigerant lines	1 pc(s).	3311.495	3311.496	10

Any questions about our services or maintenance agreements?

Do you need an individual, personal consultation or a service quote?

Our service specialists will be happy to assist you.

- Manufacturers' warranty
- Configuration and assembly
- Inspection
- Climate control pipework
- Commissioning
- Leak test
- Modernisation
- Maintenance
- Service agreements (SLA)
- Spare parts
- Response time
- Wearing parts

Please direct enquiries to the local Rittal Service organisation, either by e-mail or phone.
www.rittal.com/contact

Rittal Service

CMC III Processing Unit/Compact



www.rittal.com/r?lcu-cmc3-en

CMC III

Liquid Cooling Unit



Network/server enclosures TS IT Cat. 34, page 90 Micro Data Center Cat. 34, page 466

Applications:

- Cooling unit for TS IT server enclosures and for Micro Data Center in a redundant design

Benefits:

- Space-saving solution by installing the redundantly designed internal unit in the TS IT server enclosure or the Micro Data Center
- Maximum energy efficiency due to EC fan technology and IT-based control
- Control of the server inlet temperature
- The inverter-controlled compressor adapts the cooling output to the current heat loss inside the enclosure
- Absorbed thermal energy is emitted directly to the ambient air at the (inverter-controlled) external unit's location, without heating up the installation room

Functions:

- The redundant variants have two cooling circuits and controllers inside the internal unit, plus two inverter-regulated external units. The fault and operating hours changeover allows regular switching between the two external units, and ensures automatic changeover in the event of a malfunction or failure.
- The device supports "front to back" air routing typical of IT applications, and regulates the server inlet temperature to the set value

Protection category IP to IEC 60 529:

- Internal unit IP 20
- External unit IP X4

Supply includes:

- Internal unit (evaporator coil)
- 2 external units (inverter-controlled)
- 482.6 mm (19") mounting trim panel with display and control components
- Condensate hose

Note:

- Below the operating limit, fluctuations in the air inlet temperature are possible

- The electrical connection is made on the external unit; the internal unit is supplied by the external unit
- A separate power supply may be needed, depending on the external unit

Installation in TS IT:

- 482.6 mm (19") levels must be designed as mounting angles and offset in the width by 50 mm off-centre
- The front distance between the 482.6 mm (19") mounting angles and the front edge of the TS frame must be at least 100 mm
- Not suitable for combination with 482.6 mm (19") mounting frame
- Two punched sections with mounting flanges are required for attachment on the inner mounting level
- To separate the hot/cold zones within an enclosure, an air baffle plate for TS IT is required
- A Flex-Block base/plinth is required to route the cable downwards

Further technical information:

Available on the Internet

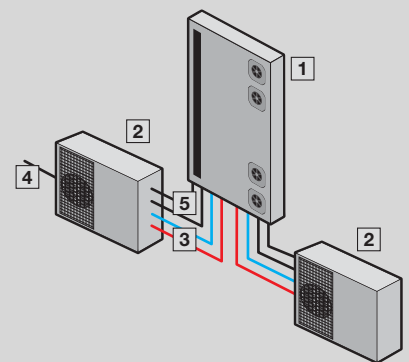

- 1 Internal unit
- 2 External unit
- 3 Refrigerant lines
- 4 Power supply
- 5 Data cable

LCU DX, redundant

Design	Packs of	LCU DX 3 kW redundant	LCU DX 6.5 kW redundant	Page
Model No.	1 pc(s).	3311.491	3311.493	
For enclosure width mm		800	800	
For enclosure height mm		≥ 1800	≥ 1800	
For enclosure depth mm		≥ 1000	≥ 1000	
External unit, W x H x D mm		810 x 558 x 310	845 x 700 x 320	
Internal unit, W x H x D mm		105 x 1550 x 820	105 x 1550 x 820	
Type of electrical connection		Connection clamp	Connection clamp	
Rated operating voltage V, ~, Hz		230, 1~, 50	230, 1~, 50	
Rated current (max.) A		7	15.9	
Pre-fuse A		16	20	
Duty cycle %		100	100	
Useful cooling output L22 L35 kW		3	6.5	
Cooling medium		R410a	R410a	
Sound pressure level at a distance of 10 m (external unit) dB(A)		40	40	
Operating temperature range (external unit)		-20°C...+45°C	-20°C...+45°C	
Weight as delivered kg		154.0	174.0	
Accessories				
Refrigerant lines	1 pc(s).	3311.495	3311.496	10

Rittal data centre health check – know what's going on!

On request, as part of a maintenance order or service agreement, we will carry out the following health check on your data centre, free of charge:

- Perform an evaluation
- Assess the risk
- Highlight potential savings
- Offer solutions

Please direct enquiries to the local Rittal Service organisation, either by e-mail or phone.
www.rittal.com/contact

Rittal Service

Power Distribution Unit



PDU – Power Distribution Unit



www.rittal.com/r?lcu-pdu-en

Accessories/CMC III

Refrigerant lines

for LCU DX

For connecting the internal and external unit of the LCU DX. Consisting of intake gas line and liquid line. The refrigerant lines are insulated.

Further technical information:

Available on the Internet

Length m	20	20
Design	LCU DX 3 kW	LCU DX 6.5 kW
Product-specific scope of supply	Intake gas line 1/2" Liquid line 1/4"	Intake gas line 5/8" Liquid line 3/8"
Packs of	1 pc(s).	1 pc(s).
Model No.	3311.495	3311.496



CMC III Processing Unit Compact

Computer Multi Control (CMC) is an alarm system for network and server enclosures, standard enclosures, containers and rooms.

- It monitors temperatures, humidity, access, smoke, energy and many other physical ambient parameters
- The system is modular in nature and can be flexibly adapted to meet specific monitoring requirements
- User benefits plus exceptional savings are achieved thanks to monitoring via the network and the automation of security processes
- Redundant voltage supply, plus Power over Ethernet (PoE)
- Simple wiring with CAN bus connection system (RJ 45)
- Connection to control desk systems via OPC UA and Modbus/TCP

More information can be found on the Rittal website.

Material:

- Plastic

Surface finish:

- Front: Smooth
- Enclosure: Textured

Colour:

- Front: RAL 9005
- Enclosure: RAL 7035

Protection category IP to IEC 60 529:

- IP 30

Supply includes:

- Basic system
- Quick-start instructions
- 4 mounting feet

Approvals:

- cULus

W x H x D mm	138 x 40 (1 U) x 120 + 12 (front assembly)
Operating temperature range	0°C...+45°C
Operating humidity range	5 – 95% relative humidity, non-condensing
Sensors/CAN bus connection units	max. 4
Max. overall cable length for CAN bus	1 x 50 m
Model No.	7030.010

CMC III accessories

Model No.	
7030.060	Power pack 100 – 240 V AC to 24 V DC
7200.215	Connection cable C13/C14
7030.070	Mounting unit, 1 U
7030.080	Programming cable USB
7030.090	CAN bus connection cable 0.5 m
7030.091	CAN bus connection cable 1 m
7030.111	Temperature/humidity sensor

Further accessories can be found in Catalogue 34, from page 446

Configuration table

Possible TS IT/LCU DX combinations

The following TS IT variants from the modular TS IT system are available for installing the LCU DX internal unit in the TS IT:

482.6 mm (19") interior installation	Front door	Rear door	Roof	Base	Width mm	Height mm	Depth mm	Packs of	Packs required	Model No.
482.6 mm (19") mounting angles	Glazed door	Two-part, solid	With cable entry	Open	800	2000	1000	1 pc(s).	1	5509.120
					800	2000	1200	1 pc(s).	1	5511.120
					800	2200	1000	1 pc(s).	1	5514.120
					800	2200	1200	1 pc(s).	1	5516.120
Without interior installation, protection category IP 55	Glazed door	One-piece, solid	Solid	Solid	800	2000	1200	1 pc(s).	1	5511.790
					800	2000	1000	1 pc(s).	1	5509.790
					800	2200	1000	1 pc(s).	1	5514.790
					800	2200	1200	1 pc(s).	1	5516.790
Also required										
Flex-Block trim panels, solid, W x H/D: 100 x 1000 mm								1 pc(s).	1	8100.010
Flex-Block trim panels, solid, W x H/D: 100 x 800 mm								1 pc(s).	1	8100.800
Flex-Block corner pieces, 100 mm								4 pc(s).	1	8100.000
Flex-Block trim panels, solid, W x H/D: 200 x 1000 mm								1 pc(s).	1	8200.010
Flex-Block trim panels, solid, W x H/D: 200 x 800 mm								1 pc(s).	1	8200.800
Flex-Block corner pieces, 200 mm								4 pc(s).	1	8200.000
Air baffle plate for TS IT, W x H: 800 x 2000 mm								1 pc(s).	1	5501.815
Air baffle plate for TS IT, W x H: 800 x 2200 mm								1 pc(s).	1	5501.835
TS punched section with mounting flange for depth 1000 mm								4 pc(s).	1	8612.500
TS punched section with mounting flange for depth 1200 mm								4 pc(s).	1	8612.520
Also required for TS IT 55xx.120										
Gland plate, multi-piece, for depth 1000 mm										
Base mount for TS IT								2 pc(s).	1	5501.320
Gland plate, solid, with sliding panel, multi-piece								1 pc(s).	1	5502.550
Section for cable entry, centre								2 pc(s).	1	8802.080
Gland plate, multi-piece, for depth 1200 mm										
Base mount for TS IT								2 pc(s).	1	5501.350
Gland plate, solid, with sliding panel, multi-piece								1 pc(s).	1	5502.570
Section for cable entry, centre								2 pc(s).	1	8802.080

Note:

- Please follow the additional installation instructions on pages 8 and 10.

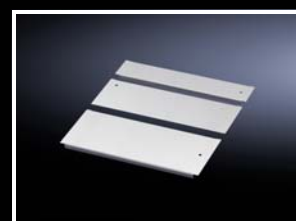
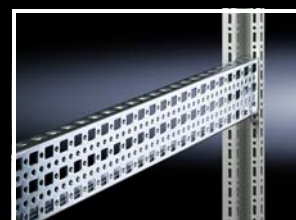

Rittal – The System.

Faster – better – everywhere.

- Enclosures
- Power Distribution
- Climate Control
- IT Infrastructure
- Software & Services

You can find the contact details of all Rittal companies throughout the world here.



www.rittal.com/contact

ENCLOSURES

POWER DISTRIBUTION

CLIMATE CONTROL

IT INFRASTRUCTURE

SOFTWARE & SERVICES



FRIEDHELM LOH GROUP