



RITTAL SR IT 机柜用户手册

RITTAL SR IT CABINET MANUAL

— 目 录 —

导言.....	1
安装说明.....	11
1. 拆卸包装	11
2. 机柜安装参数	13
3. 机柜安装相关扭力推荐表	19
4. 机柜水平调节脚的安装	21
5. 机柜间并柜的安装	23
6. 角规距离的调节	27
7. 机柜侧板的安装（选配件）	31
8. L型托架的安装（选配件）	33
9. 固定层板的安装（选配件）	37
10. 左右分段式底板的安装（选配件）	43
11. 免工具 2U 盲板的安装（选配件）	47
机柜参数性能.....	49
1.机柜描述.....	49
2.装配清单.....	52

— Contents —

Introduction	2
Mounting instruction	12
1.Disassembly of the packaging.....	12
2.Installation parameters of cabinet.....	14
3.Recommended torque table for rack.....	20
4.Installation of Leveling feet.....	22
5.Installation for cabinet Baying	24
6.Adjustment of the mounting angle	28
7. Installation of Sidepanels(optional accessory)	32
8. Installation of slide rails(optional accessory)	34
9. Installation of static shelf (optional accessory).....	38
10. Installation of Base plate(optional accessory)	44
11. Installation of toolless 2U blanking panel(optional accessory)	48
Performance of cabinet parameters.	50
1. Description of cabinet	50
2.List of assembled items.....	53

导言

产品概述

RITTAL SR IT 服务器、网络机柜适用于存储符合行业标准的 19 英寸机架式设备（包含服务器、语音、数据、网络、Internet 连接及机架式不间断电源）；采用了先进的 16 折工艺型材，拥有 78% 的通风率，外表经顶尖喷涂线处理的高品质机柜。

RITTAL SR IT Cabinet

型号	W(宽 mm) H(高 mm) D(深 mm)	颜色	前钢板网孔单门	前钢板玻璃门	后钢板网孔双门	后钢板单门	后板	进线顶 1	进线顶 2
1194453	W600H2000D1000	RAL9005	1		1			1	
1194454	W600H2000D1100	RAL9005	1		1			1	
1194455	W600H2000D1200	RAL9005	1		1			1	
1194456	W800H2000D1000	RAL9005	1		1			1	
1194457	W800H2000D1100	RAL9005	1		1			1	
1194458	W800H2000D1200	RAL9005	1		1			1	
1194459	W800H2000D800	RAL9005	1		1			1	
1194460	W600H2200D1000	RAL9005	1		1			1	
1194461	W600H2200D1100	RAL9005	1		1			1	
1194462	W600H2200D1200	RAL9005	1		1			1	
1194463	W800H2200D1000	RAL9005	1		1			1	
1194464	W800H2200D1100	RAL9005	1		1			1	
1194465	W800H2200D1200	RAL9005	1		1			1	
1194466	W600H2000D600	RAL9005		1			1		1
1194467	W600H2000D800	RAL9005		1		1			1
1194468	W600H2000D1000	RAL9005		1		1			1
1194469	W800H2000D800	RAL9005		1		1			1

Introduction

Product overview

RITTAL SR IT server、internet cabinet is suitable for storing 19 inch rack type devices that meet industry standards (including server, voice, data, network, Internet connection, and rack type uninterrupted power supply);SRIT cabinet have advanced 16 folding process frame and 78% ventilation rate doors, The cabinet surface is processed by Rittal high quality ecoating lines.

RITTAL SR IT Cabinet

TYPE	W(width mm) H (height mm) D (depth mm)	color	Front vented single door	Front glassed single door	Rear Vented Double door	Rear single door	Rear wall	Cable Roof 1	Cable Roof 2
1194453	W600H2000D1000	RAL9005	1		1			1	
1194454	W600H2000D1100	RAL9005	1		1			1	
1194455	W600H2000D1200	RAL9005	1		1			1	
1194456	W800H2000D1000	RAL9005	1		1			1	
1194457	W800H2000D1100	RAL9005	1		1			1	
1194458	W800H2000D1200	RAL9005	1		1			1	
1194459	W800H2000D800	RAL9005	1		1			1	
1194460	W600H2200D1000	RAL9005	1		1			1	
1194461	W600H2200D1100	RAL9005	1		1			1	
1194462	W600H2200D1200	RAL9005	1		1			1	
1194463	W800H2200D1000	RAL9005	1		1			1	
1194464	W800H2200D1100	RAL9005	1		1			1	
1194465	W800H2200D1200	RAL9005	1		1			1	
1194466	W600H2000D600	RAL9005		1			1		1
1194467	W600H2000D800	RAL9005		1		1			1
1194468	W600H2000D1000	RAL9005		1		1			1
1194469	W800H2000D800	RAL9005		1		1			1

600 宽网孔门机柜样式

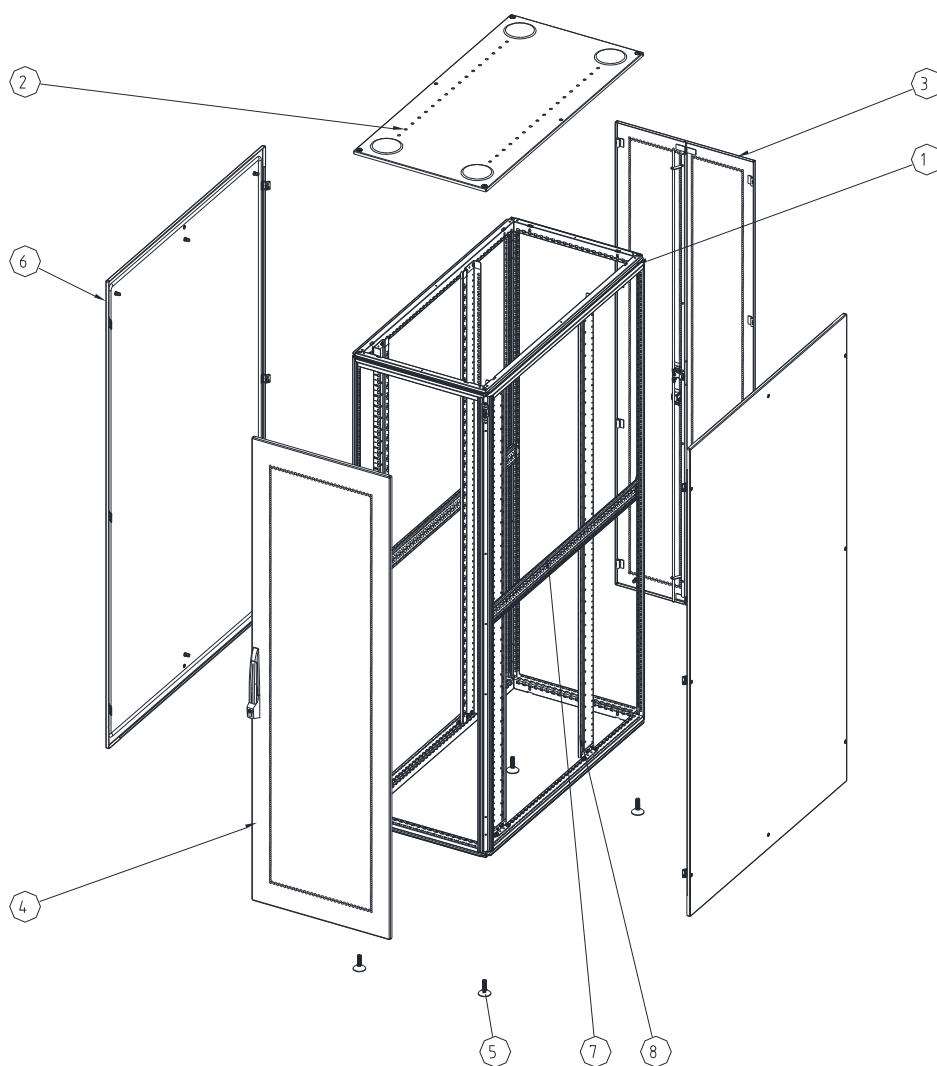

1. 框架
2. 顶盖
3. 后左右门
4. 前门
5. 水平调节脚（选配件）
6. 侧板(选配件)
7. 机柜深度支撑
8. 19 英寸安装角规

600 wide vented door cabinet style

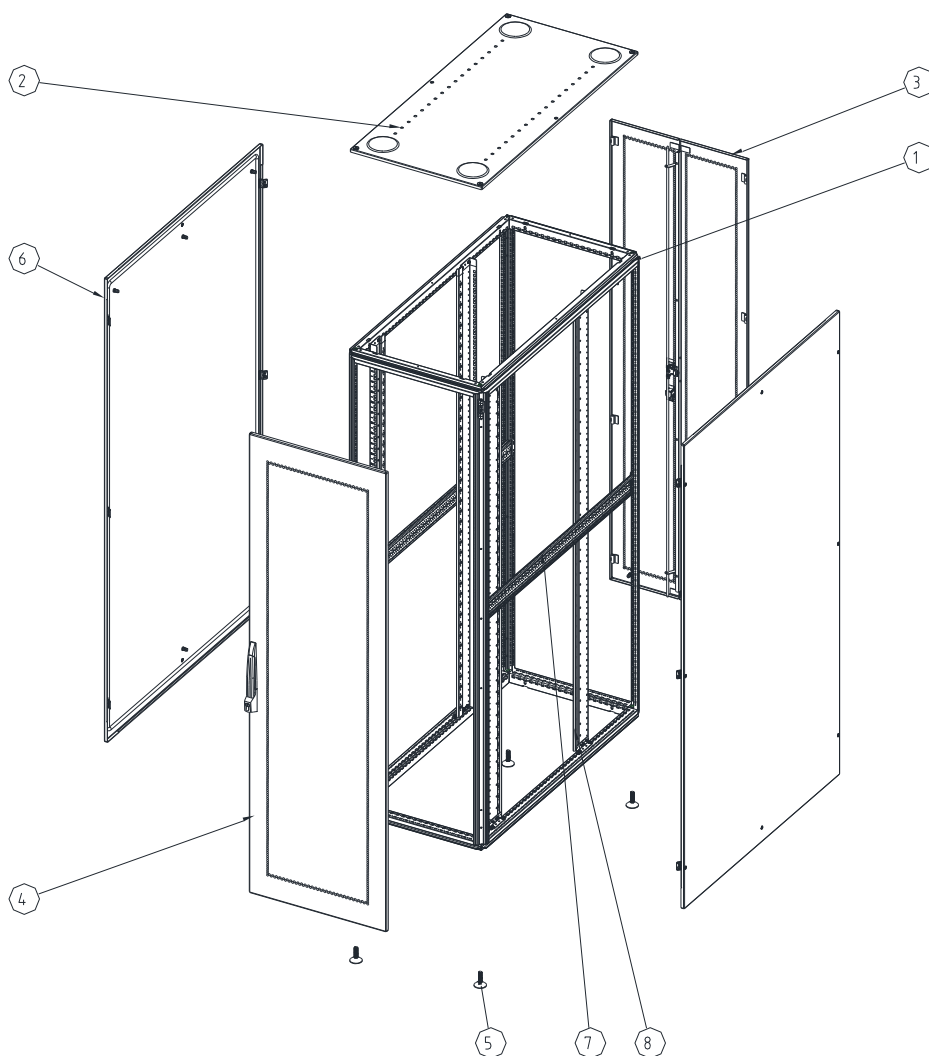

1. Frame
2. Top panel
3. Rear door
4. Front door
5. Leveling feet (optional accessory)
6. Side panel (optional accessory)
7. Depth stay
8. 19' mounting angle

800 宽网孔门机柜样式

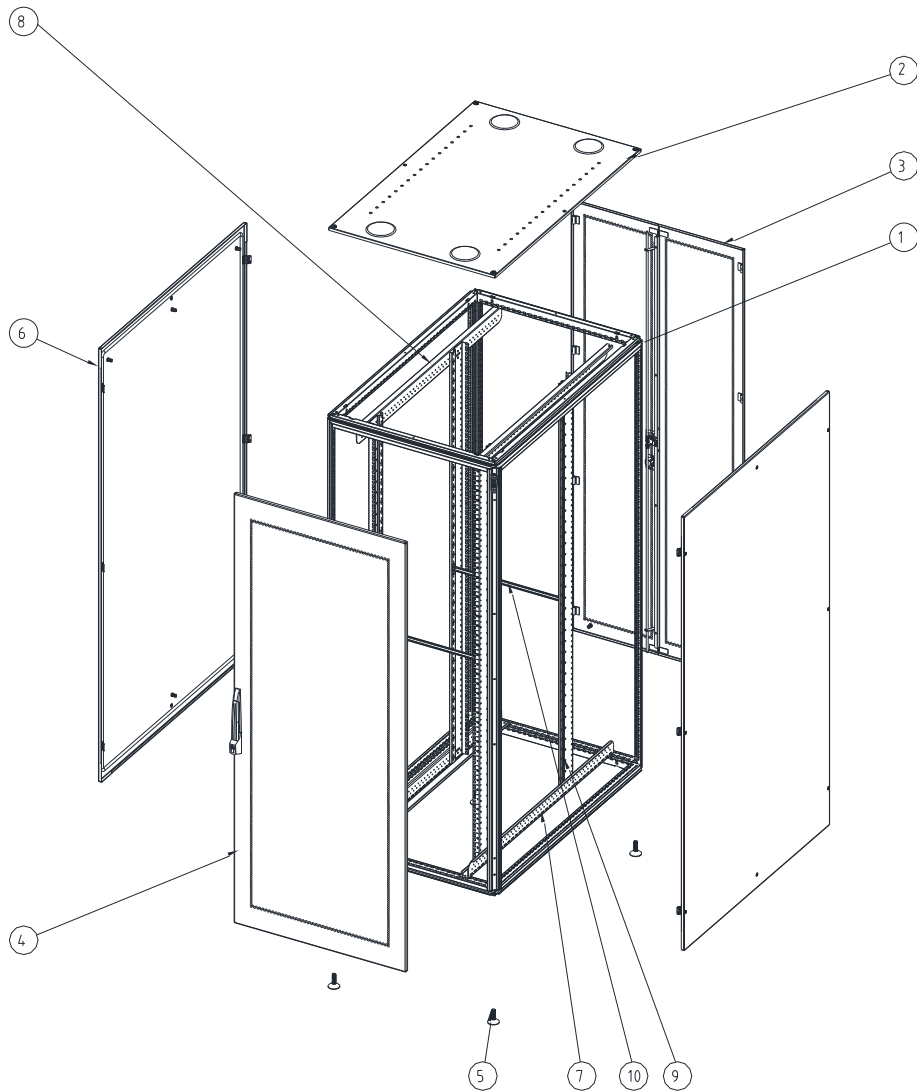

1. 框架
2. 顶盖
3. 后左右门
4. 前门
5. 水平调节脚（选配件）
6. 侧板(选配件)
7. 角规底部深度支撑
8. 角规顶部深度支撑
9. 19 英寸角规
10. 角规横向支撑

800 wide vented door cabinet style

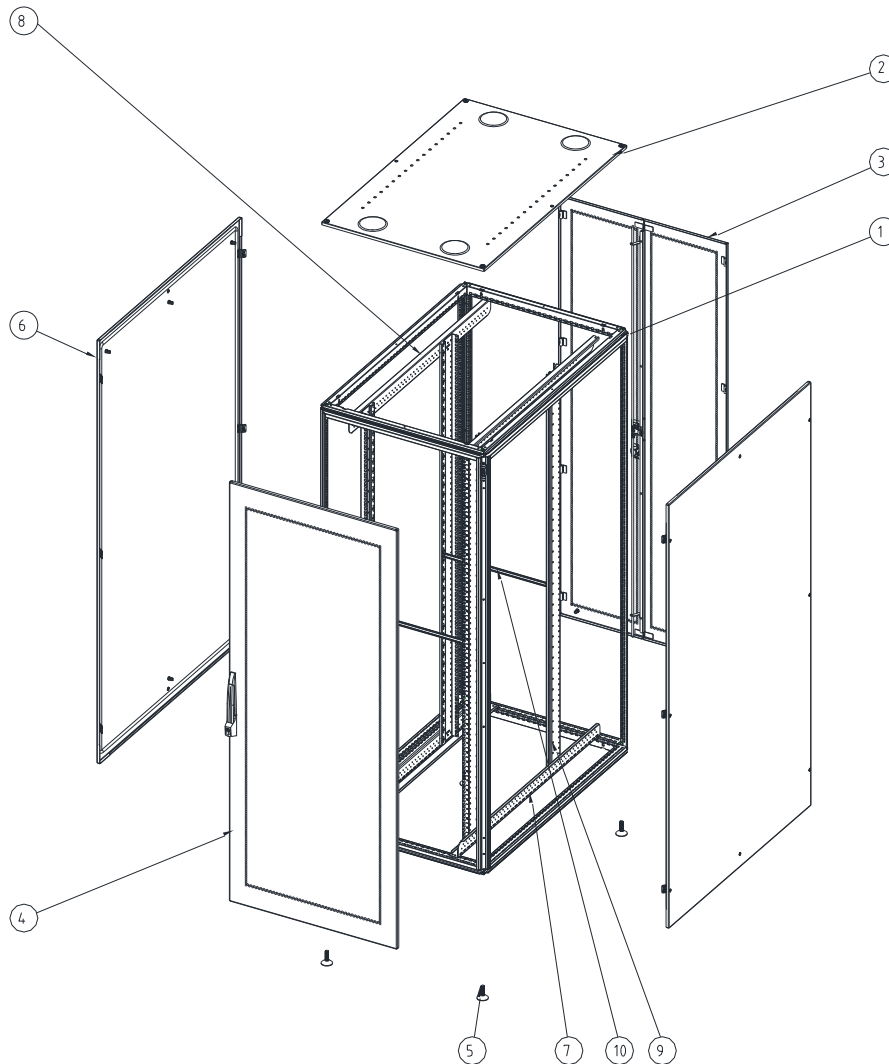

1. Frame
2. Top panel
3. Rear door
4. Front door
5. Leveling feet (optional accessory)
6. Side panel (optional accessory)
7. Bottom mounting angle bracket
8. Top mounting angle bracket
9. 19' mounting angle
10. Mounting angle horizontal bkt

600 宽玻璃门机柜样式

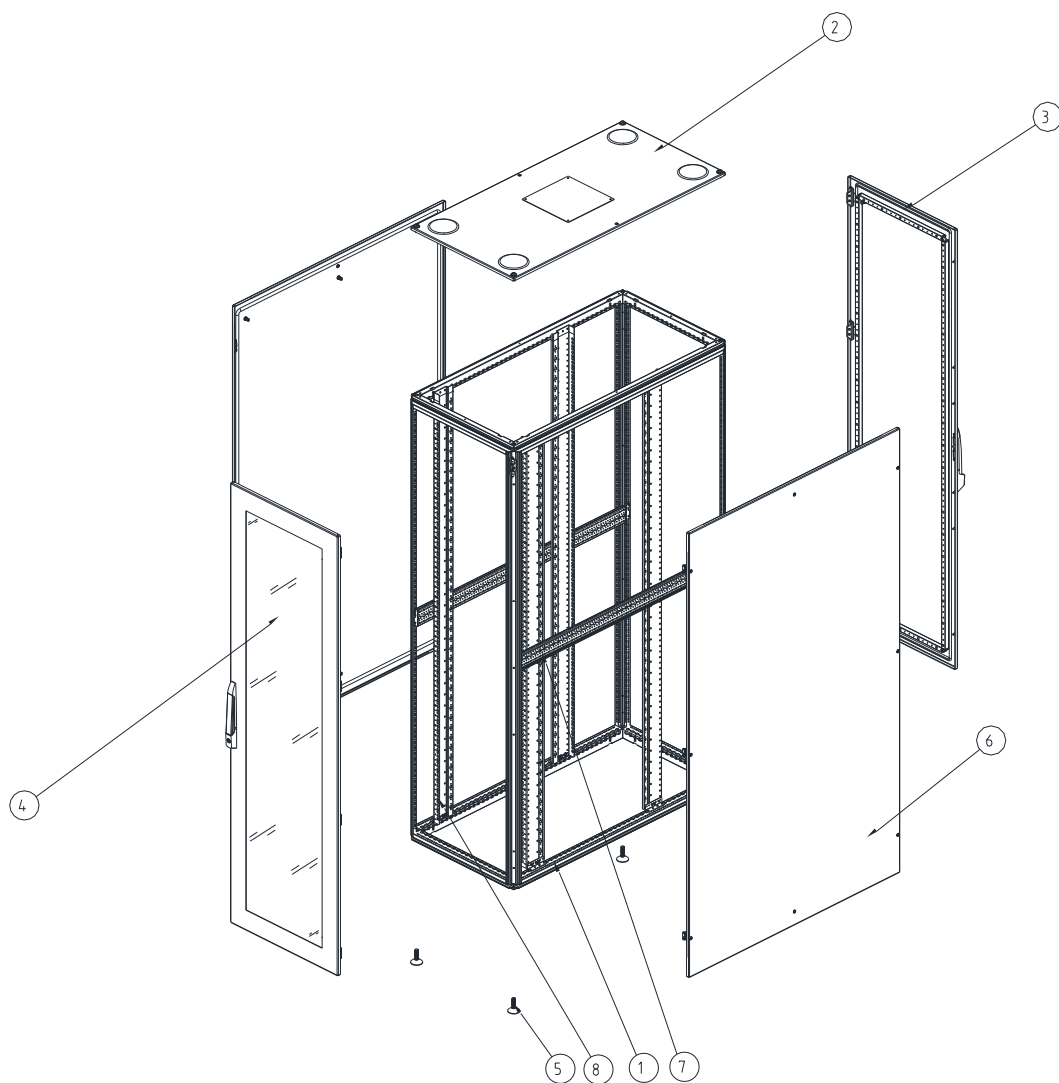

1. 框架
2. 顶盖
3. 后门或后板
4. 前钢板玻璃门
5. 水平调节脚（选配件）
6. 侧板(选配件)
7. 机柜深度支撑
8. 19 英寸安装角规

600 wide glass door cabinet style

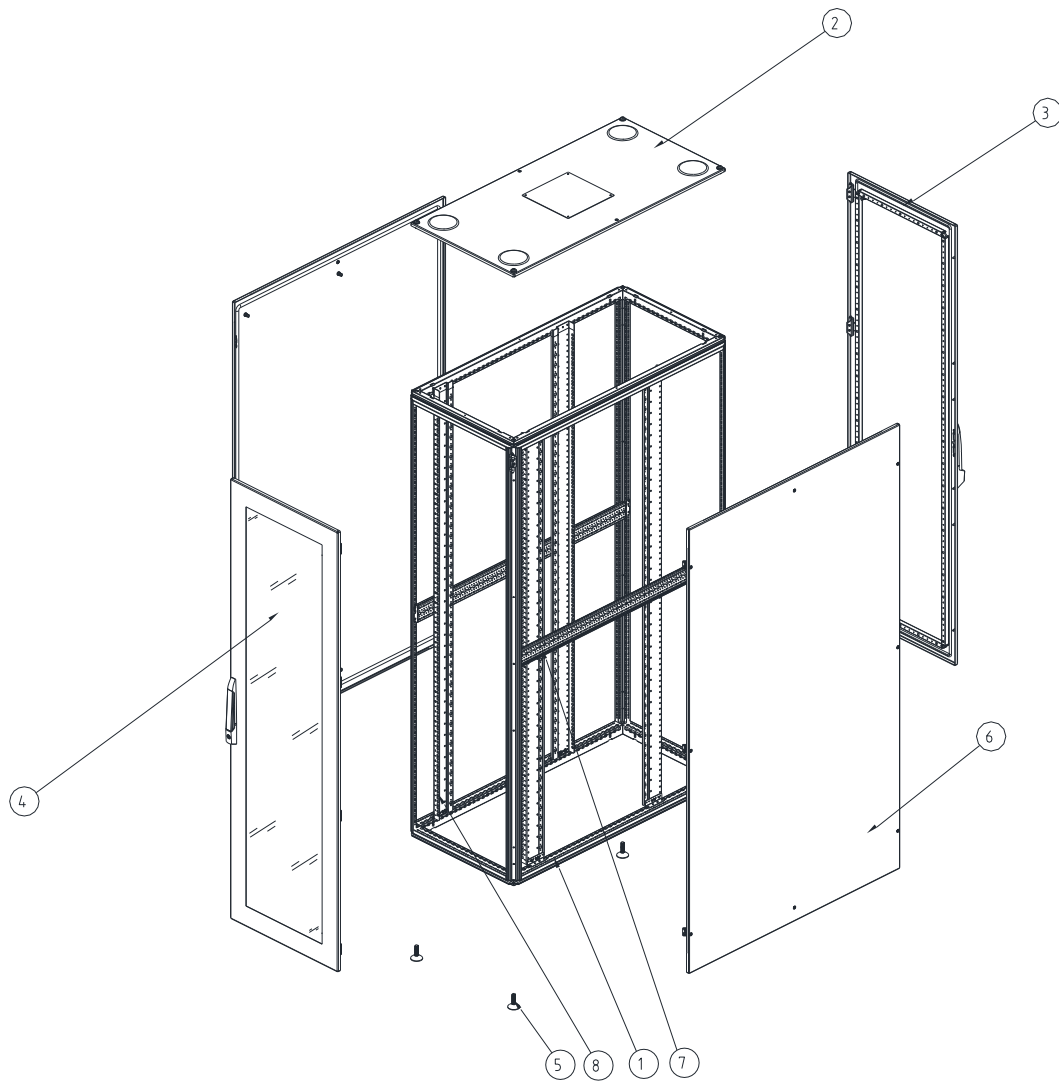

1. Frame
2. Top panel
3. Rear door or rear panel
4. Front glass door
5. Leveling feet (optional accessory)
6. Side panel (optional accessory)
7. Depth stay
8. 19' mounting angle

800 宽玻璃门机柜样式

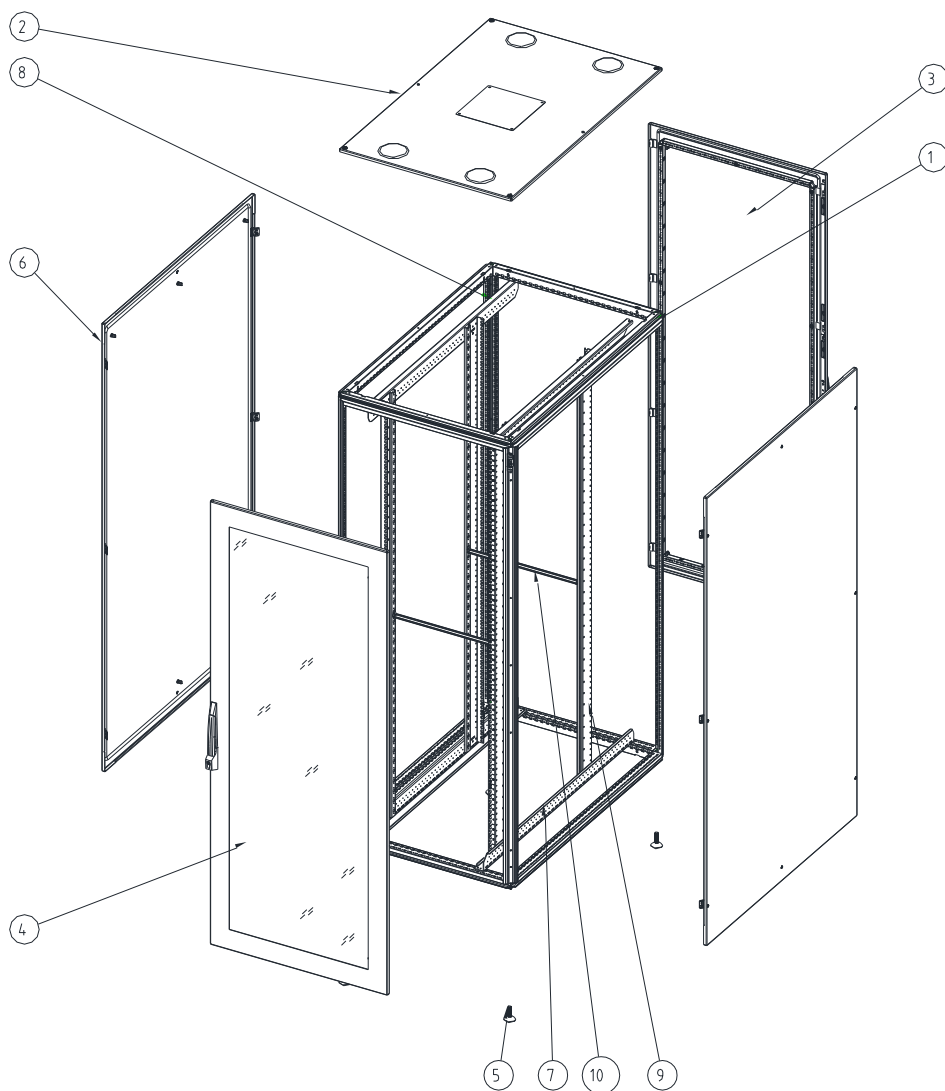

1. 框架
2. 顶盖
3. 后门或者后板
4. 前钢板玻璃门
5. 水平调节脚（选配件）
6. 侧板(选配件)
7. 角规底部深度支撑
8. 角规顶部深度支撑
9. 19 英寸角规
10. 角规横向支撑

800 wide glass door cabinet style

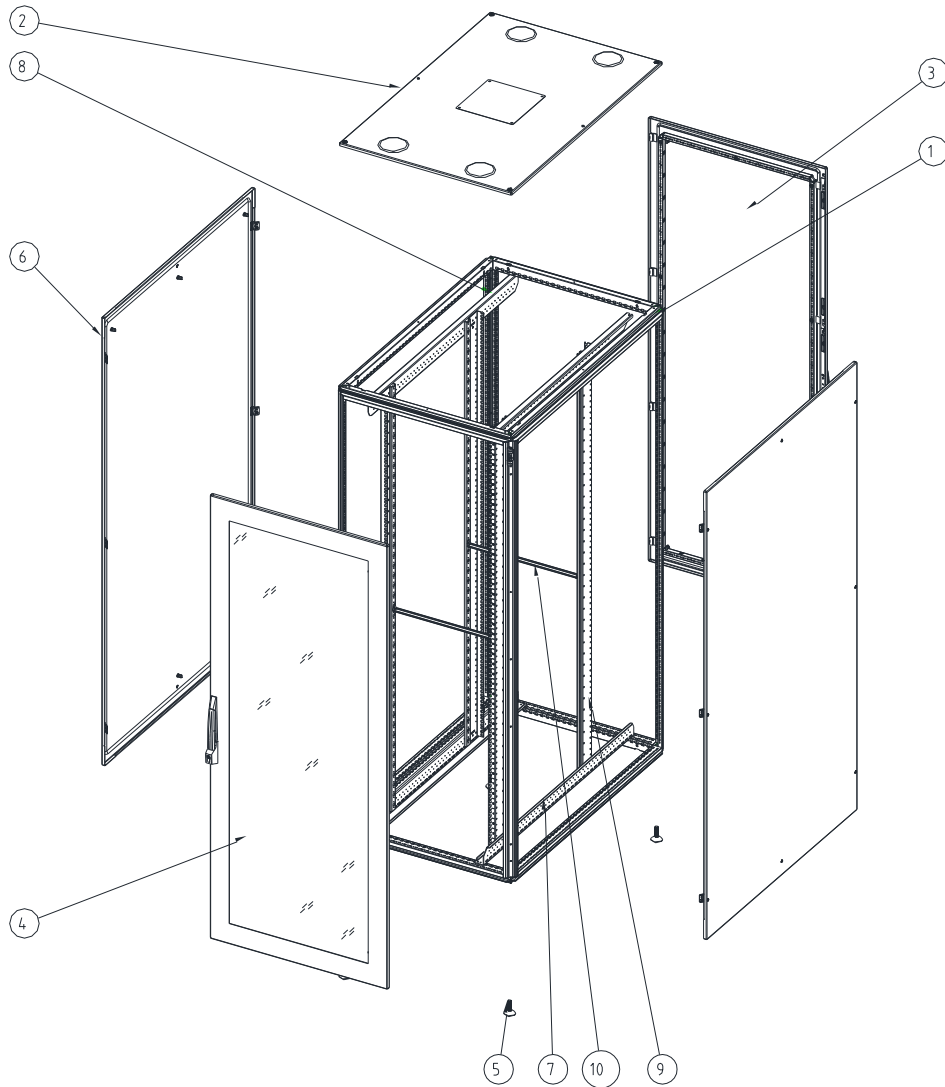

1. Frame
2. Top panel
3. Rear door or rear panel
4. Front glass door
5. Leveling feet (optional accessory)
6. Side panel (optional accessory)
7. Bottom mounting angle bracket
8. Top mounting angle bracket
9. 19' mounting angle
10. Mounting angle horizontal bracket

1. 拆卸包装

机柜包装方式

机柜底部加木托盘，再用卡爪将机柜固定在木托盘上，白色塑料袋套住整个机柜，顶部配有纸护角，四角用纸立柱角保护，然后外部缠绕膜缠绕；

- 外包装尺寸：
 $W \times H \times D = (\text{机柜宽度} + 60 \text{ 毫米}) \times (\text{机柜高度} + 140 \text{ 毫米}) \times (\text{机柜深度} + 130 \text{ 毫米})$
- 包装材质：PE 缠绕膜, PE 袋, 打包带, 纸立柱, 纸护角。

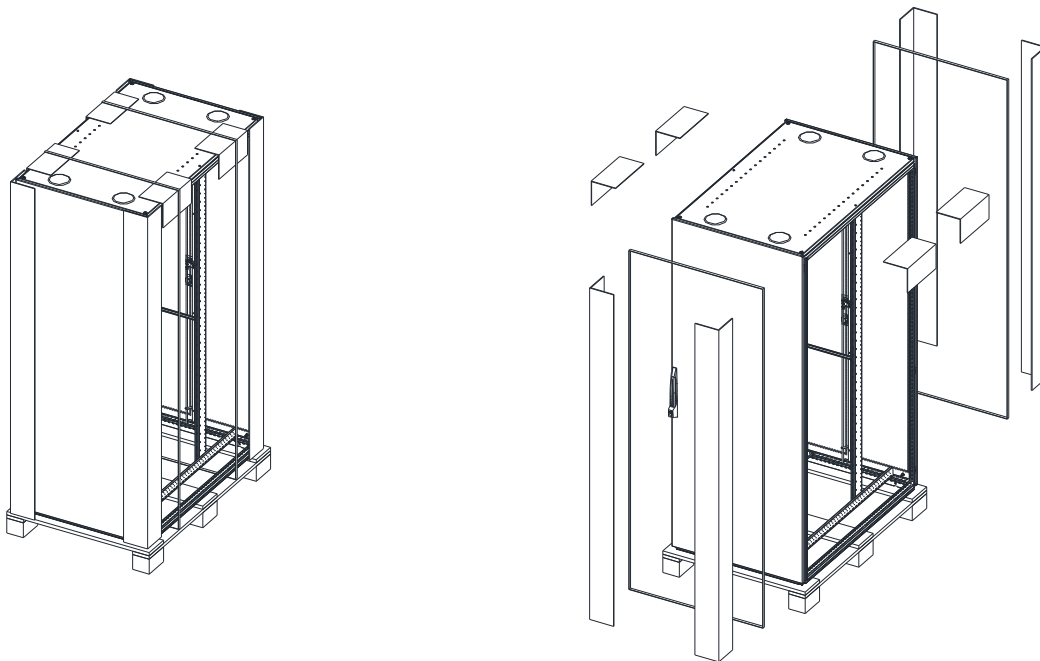

开启包装：

- 剪开打包带；
- 去掉 PE 缠绕膜、PE 袋
- 去掉纸护角，纸立柱；
- 去掉机柜固定件，将机柜抬离木托盘，注意请不要少于 2 个人搬动机柜；
- 机柜摆放到位后请选择合适的方法将机柜固定，以防机柜倾倒；

1. Disassembly of the packaging

Packaging of cabinet

Firstly cabinet is fixed on the wooden pallets, then Cover the whole cabinet with white plastic bag, then,with corner protection and four corner carton,finally wrapped the cabinet.

- Dimension of package:
 $W \times H \times D = (\text{width of cabinet} + 60\text{mm}) \times (\text{height of cabinet} + 140\text{mm}) \times (\text{depth of cabinet} + 130\text{mm})$
- packing material: PE film, PE bag, strip, corner carton, corner protection.

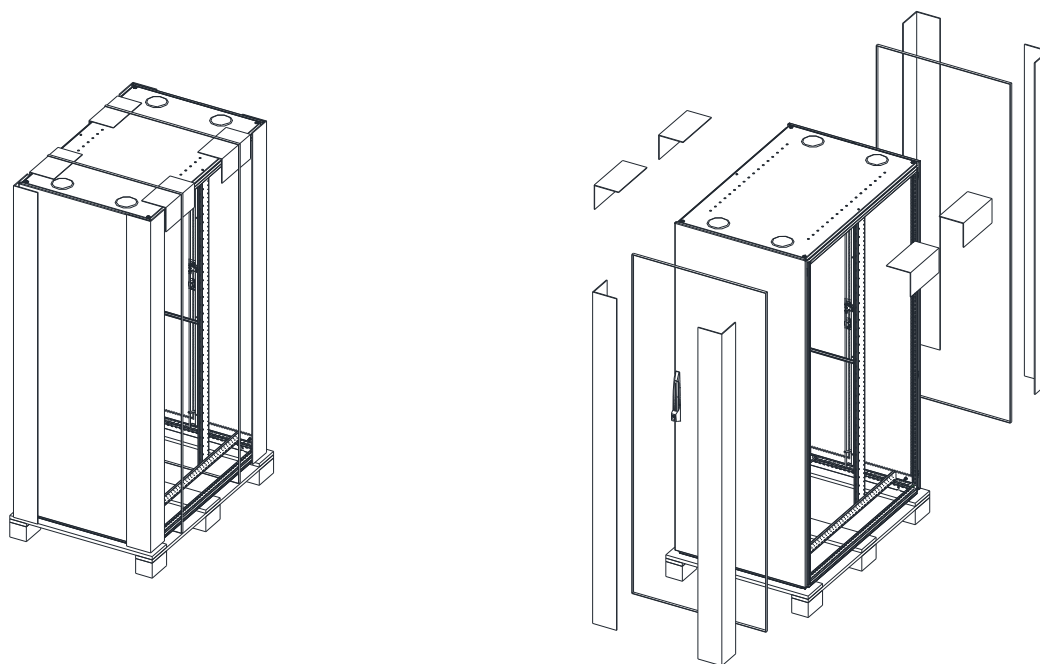

Disassembly of the packaging:

- Cut strip;
- Remove PE film, PE bag;
- Remove corner carton and corner protection;
- Remove fixing bracket of cabinet, Lift the cabinet from the wooden tray. Please do not use less than 2 people to move the cabinet.
- Please choose the appropriate method to fix the cabinet preventing the dumping

2. 机柜安装参数

□ 19 英寸角规安装宽度尺寸

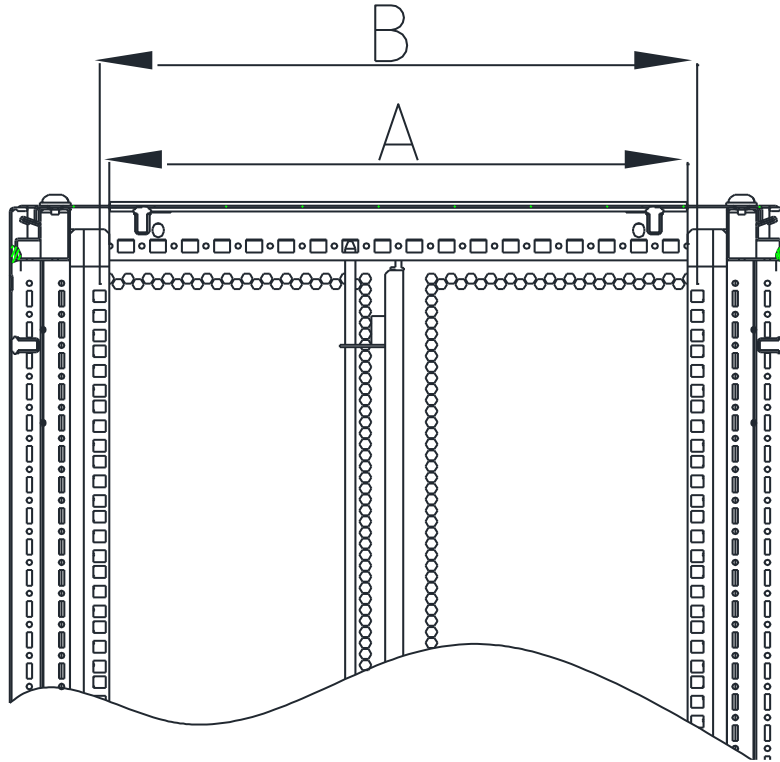

A=Front Cabinet Aperture	B = Hole-to-Hole spacing
451mm -1/+1.6mm	465mm [18.307"] nominal

□ 19 英寸安装孔尺寸

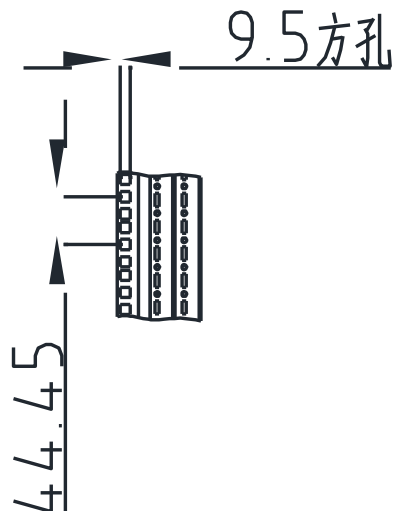

2. Installation parameters of cabinet

- 19' dimension of mounting angle

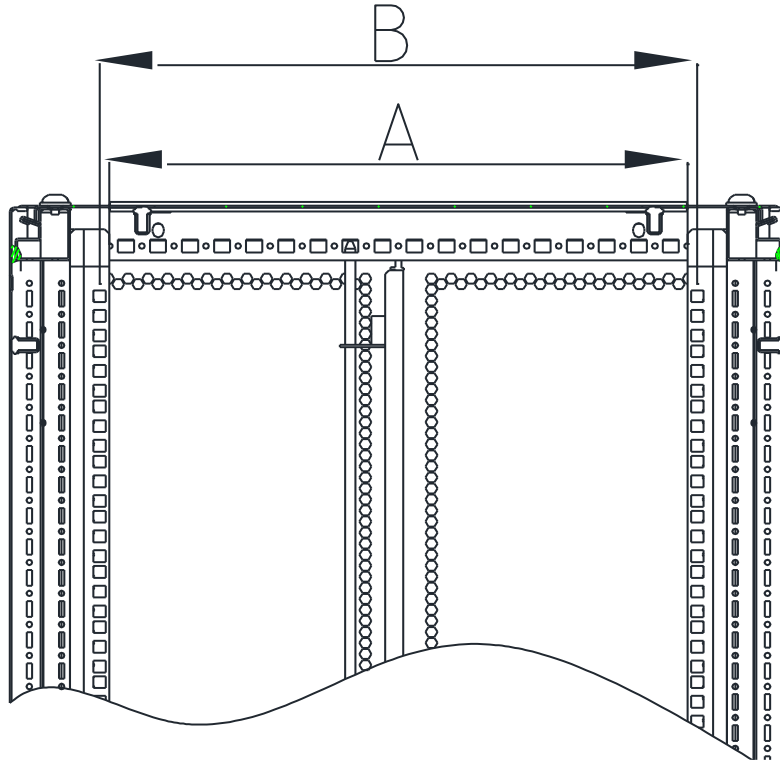

A=Front Cabinet Aperture	B = Hole-to-Hole spacing
451mm -1/+1.6mm	465mm [18.307"] nominal

- 19' dimension of mounting hole

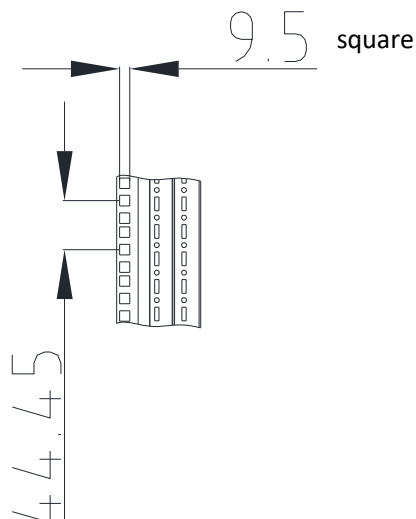

□ 角规出厂安装位置

机柜前角规面到型材内侧为 71mm，前后角规面距离为 F(mm)。

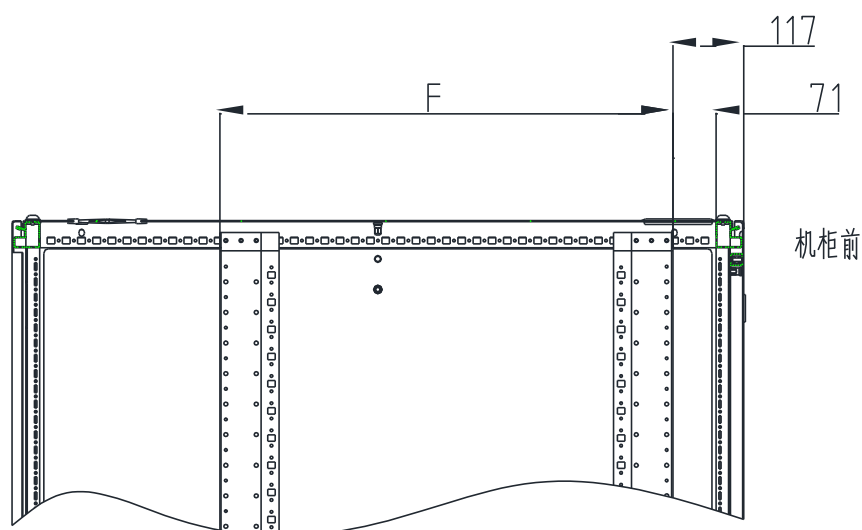

型号	W(宽 mm) H(高 mm) D(深 mm)	前后角规距离 F (mm)
1194453	W600H2000D1000	645
1194454	W600H2000D1100	745
1194455	W600H2000D1200	745
1194456	W800H2000D1000	645
1194457	W800H2000D1100	745
1194458	W800H2000D1200	745
1194459	W800H2000D800	545
1194460	W600H2200D1000	645
1194461	W600H2200D1100	745
1194462	W600H2200D1200	745
1194463	W800H2200D1000	645
1194464	W800H2200D1100	745
1194465	W800H2200D1200	745
1194466	W600H2000D600	345
1194467	W600H2000D800	545
1194468	W600H2000D1000	645
1194469	W800H2000D800	545

- factory installation position of mounting angles

The distance between front mounting angle and inner frame is 71mm, the distance between front mounting angle and rear mounting angle is F(mm)。

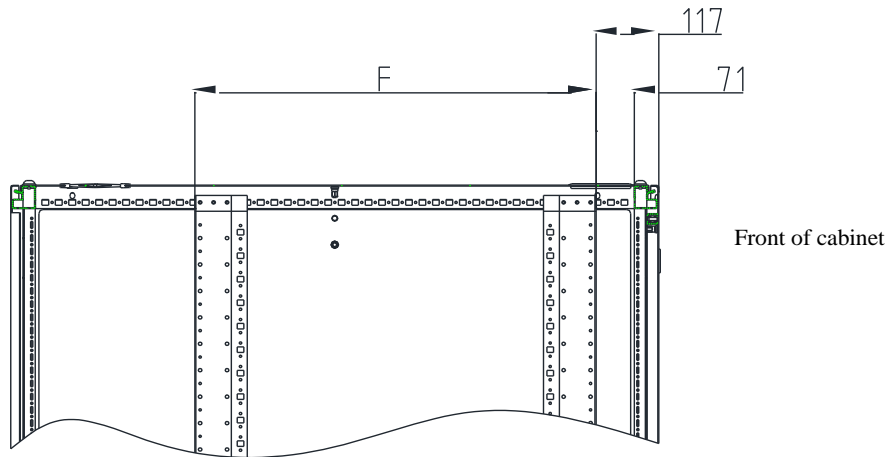

TYPE	W(width mm) H (height mm) D (depth mm)	Distance F (mm)
1194453	W600H2000D1000	645
1194454	W600H2000D1100	745
1194455	W600H2000D1200	745
1194456	W800H2000D1000	645
1194457	W800H2000D1100	745
1194458	W800H2000D1200	745
1194459	W800H2000D800	545
1194460	W600H2200D1000	645
1194461	W600H2200D1100	745
1194462	W600H2200D1200	745
1194463	W800H2200D1000	645
1194464	W800H2200D1100	745
1194465	W800H2200D1200	745
1194466	W600H2000D600	345
1194467	W600H2000D800	545
1194468	W600H2000D1000	645
1194469	W800H2000D800	545

机柜角规可调最大距离 G(mm)见下图及表。

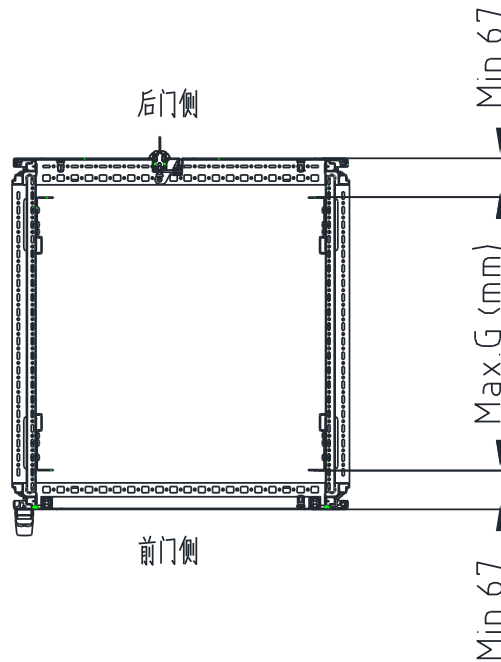

型号	W(宽 mm) H (高 mm) D (深 mm)	前后角规可调 最大距离 G (mm)	前后角规可调 最小距离 K (mm)
1194453	W600H2000D1000	870	195
1194454	W600H2000D1100	970	195
1194455	W600H2000D1200	1070	195
1194456	W800H2000D1000	870	195
1194457	W800H2000D1100	970	195
1194458	W800H2000D1200	1070	195
1194459	W800H2000D800	670	195
1194460	W600H2200D1000	870	195
1194461	W600H2200D1100	970	195
1194462	W600H2200D1200	1070	195
1194463	W800H2200D1000	870	195
1194464	W800H2200D1100	970	195
1194465	W800H2200D1200	1070	195
1194466	W600H2000D600	470	195
1194467	W600H2000D800	670	195
1194468	W600H2000D1000	870	195
1194469	W800H2000D800	670	195

The maximum distance between front and rear mounting angle G(mm) can be found out from below figure and table.

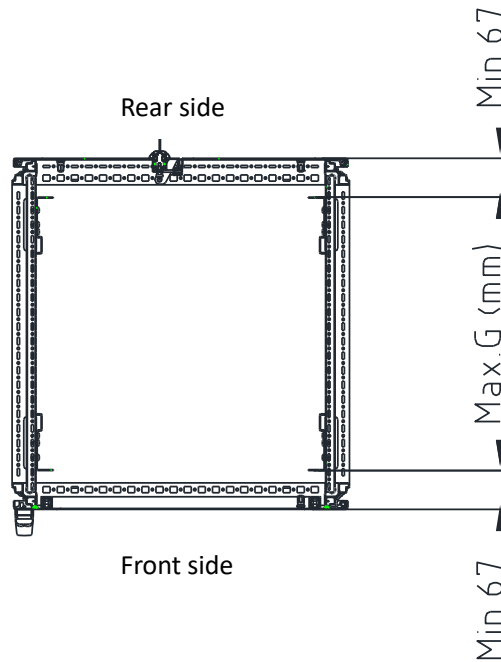

TYPE	W(width mm)H(height mm) D (depth mm)	Adjustable maximum distance G (mm)	Adjustable minimum distance K (mm)
1194453	W600H2000D1000	870	195
1194454	W600H2000D1100	970	195
1194455	W600H2000D1200	1070	195
1194456	W800H2000D1000	870	195
1194457	W800H2000D1100	970	195
1194458	W800H2000D1200	1070	195
1194459	W800H2000D800	670	195
1194460	W600H2200D1000	870	195
1194461	W600H2200D1100	970	195
1194462	W600H2200D1200	1070	195
1194463	W800H2200D1000	870	195
1194464	W800H2200D1100	970	195
1194465	W800H2200D1200	1070	195
1194466	W600H2000D600	470	195
1194467	W600H2000D800	670	195
1194468	W600H2000D1000	870	195
1194469	W800H2000D800	670	195

3. 机柜安装紧固件扭力推荐表

项次	物料号	紧固件尺寸	推荐扭力	单位	用处
1	607052	ST 5X12	5 +1	Nm	角规, 接地
2	241487	M5X8 螺栓	2+/-0.5	Nm	门锁
3	337982	ST 5.5X13	5 +1	Nm	L型滑轨、层板
4	207312	M6X18.8 螺栓	2+/-0.5	Nm	门方管加强筋
5	241485	M6X12 螺栓	8 +1	Nm	门铰链、门锁挡块、并柜
6	405421	M12*20 螺栓	10 +2	Nm	顶板
7	200016	M8_螺母	8-10	Nm	接地

3. Recommended torque table for rack

Item	Material Number	Screw Size	Recommended torque	unit	where used
1	607052	ST 5X12	5 +1	Nm	Mounting angles, earthing
2	241487	M5X8 stud	2+/-0.5	Nm	lock
3	337982	ST 5.5X13	5 +1	Nm	slide rails, shelf
4	207312	M6X18.8 stud	2+/-0.5	Nm	door tube
5	241485	M6X12 stud	8 +1	Nm	door hinge, door block, baying
6	405421	M12*20	10 +2	Nm	Roof
7	200016	M8_Nut	8-10	Nm	Rack earthing

4. 机柜水平调节脚安装

1.用户可以在威图SR IT 机柜底部安装水平调节脚来调节由于地面不平整所造成的高度差异, 以下料号为可以直接订货的标准物料号

料号	英文描述	中文描述
1194575	New DK-PS leveling feet kit	新 DK-PS 水平调节脚

2.安装步骤

在安装机柜前, 请将机柜处于水平稳固位置, 再将水平调节脚按图示安装到合适位置, 使机柜稳固放置, 注意安装时至少需要 2 人协同操作, 以防机柜倾倒.

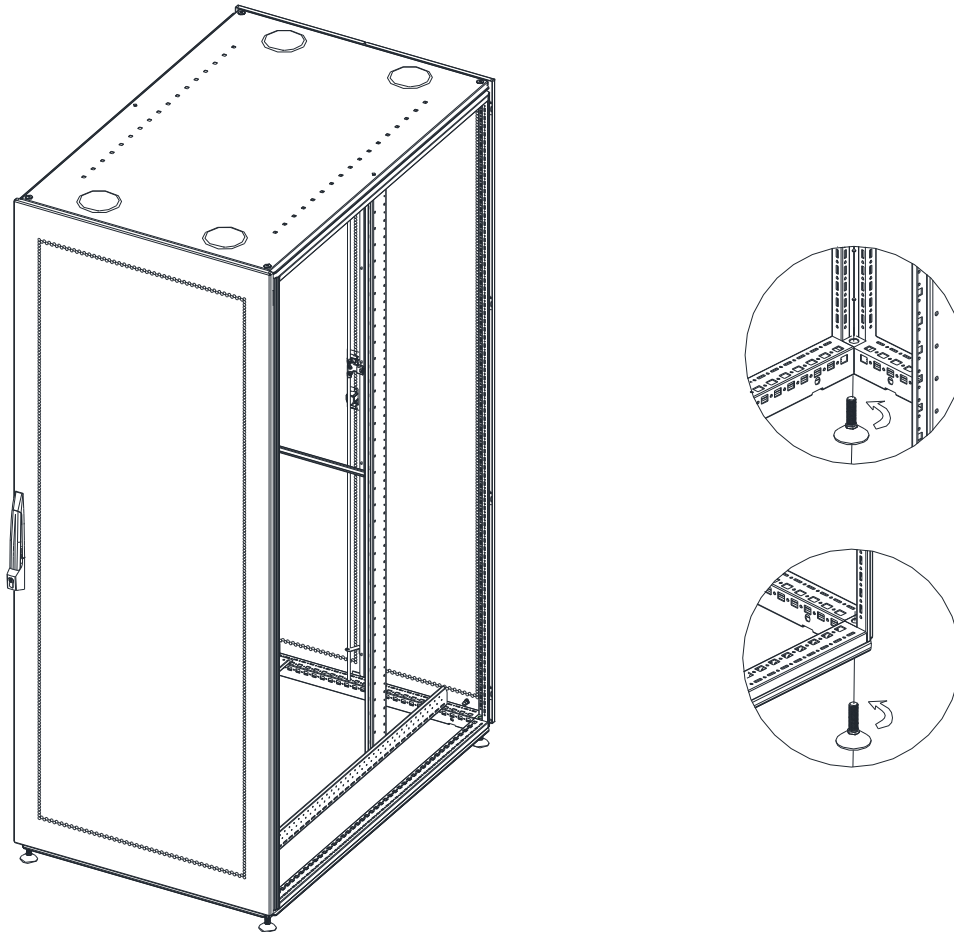

4. Installation of Leveling feet

1. Users can use leveling feet to adjust the height difference caused by uneven ground level. The following is the standard material number that can be ordered directly.

material number	English description	Chinese description
1194575	New DK-PS leveling feet kit	新 DK-PS 水平调节脚

2. Installation steps

Before installation , please let cabinet rack on the flat ground, then install leveling feet as shown to the right position, when installation it will need at least 2 people operate together, in case of the cabinet fallen.

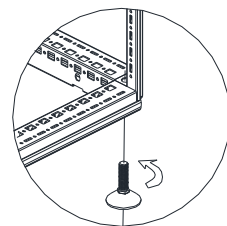
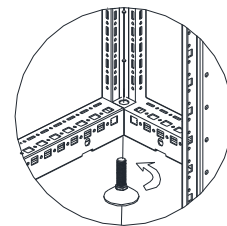
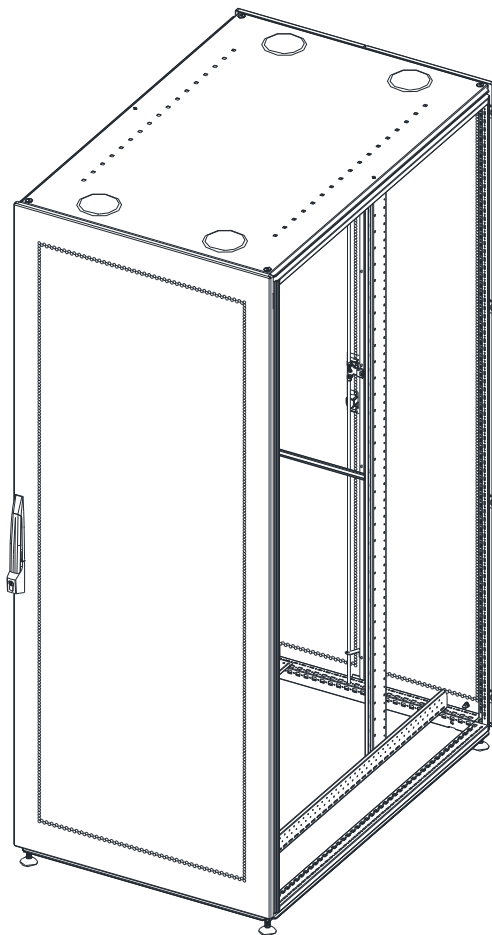

5. 机柜间并柜的安装

1.相同高度及深度的机柜可以左右进行并柜连接，并柜安装时可以选择合适的并柜件及并柜盖板，目前可直接订货的物料号如下表

并柜连接件

料号	英文描述	中文描述
8800500	TS/TS BAYING BRACKET	TS 并柜支架
8800490	TS Baying Connector External	TS 外部并柜件
8800430	TS BAYING BRACKET	TS 并柜支架
4582500	TS INTERCONNECTING BRACKETS	TS 内部并柜支架

并柜盖板

料号	英文描述	中文描述	颜色
1194448	SR IT_Baffle for TS roof D1200	SR IT_1200 深机柜顶部并柜盖板	RAL9005
1194449	SR IT_Baffle for TS roof D1100	SR IT_1100 深机柜顶部并柜盖板	RAL9005
1194450	SR IT_Baffle for TS roof D1000	SR IT_1000 深机柜顶部并柜盖板	RAL9005
1194451	SR IT_Baffle for TS roof D800	SR IT_800 深机柜顶部并柜盖板	RAL9005
1194452	SR IT_Baffle for TS roof D600	SR IT_600 深机柜顶部并柜盖板	RAL9005

5. Installation for cabinet Baying

1. The same height and depth cabinet can be connected by appropriate baying accessory. The following is the standard material number that can be ordered directly.

Baying accessory

material number	English description	Chinese description
8800500	TS/TS BAYING BRACKET	TS 并柜支架
8800490	TS Baying Connector External	TS 外部并柜件
8800430	TS BAYING BRACKET	TS 并柜支架
4582500	TS INTERCONNECTING BRACKETS	TS 内部并柜支架

Baying baffle

material number	English description	Chinese description	color
1194448	SR IT_Baffle for TS roof D1200	SR IT_1200 深机柜顶部并柜盖板	RAL9005
1194449	SR IT_Baffle for TS roof D1100	SR IT_1100 深机柜顶部并柜盖板	RAL9005
1194450	SR IT_Baffle for TS roof D1000	SR IT_1000 深机柜顶部并柜盖板	RAL9005
1194451	SR IT_Baffle for TS roof D800	SR IT_800 深机柜顶部并柜盖板	RAL9005
1194452	SR IT_Baffle for TS roof D600	SR IT_600 深机柜顶部并柜盖板	RAL9005

2. 并柜的安装

安装步骤1: 打开机柜附件包, 并取出附件包内密封条, 在机柜侧面贴并柜密封条;

安装步骤2: 安装并柜连接件;

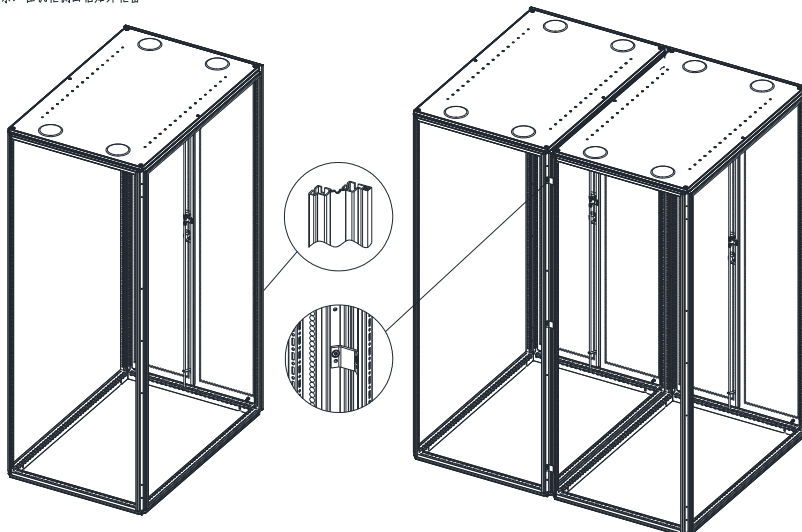

安装步骤3: 并柜盖板的安装;

安装步骤4: 并柜完成;

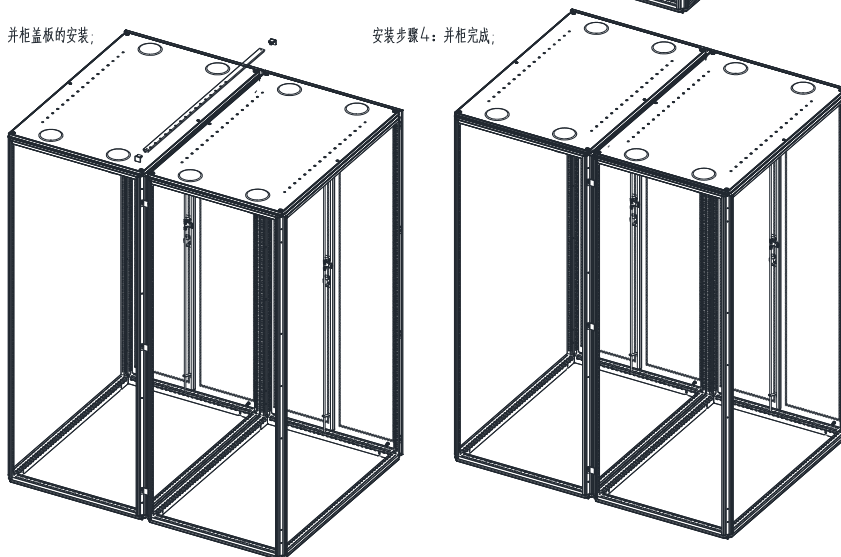

! 机柜并柜时不能安装威图侧板!

2. Installation of cabinet Baying

Step1:Open the cabinet accessory bag, take out the sealing strip,and Stick it to the side of the cabinet.

Step2:Install the baying accessory.

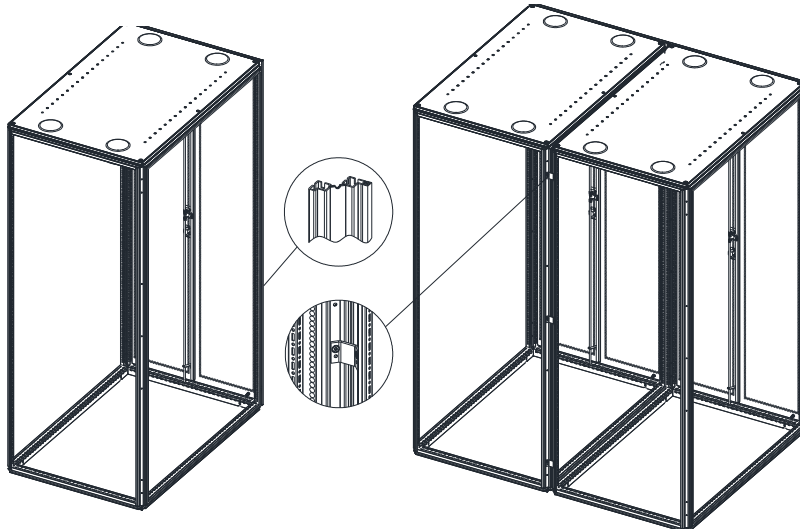

Step3:Install the baying baffle.

Step4:finished.

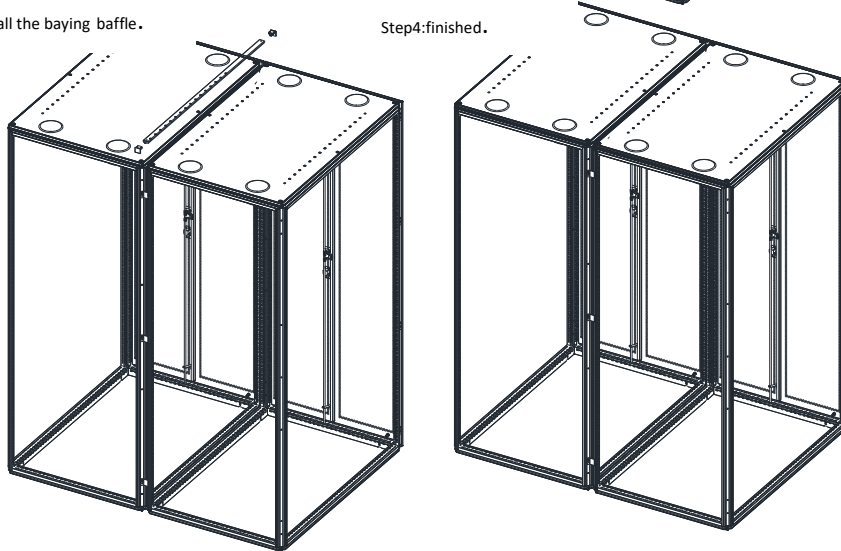

Side panels between cabinet should be removed before baying !

6. 角规距离的调节

为了满足不同深度 19" 设备安装要求，机柜内安装角规可进行前后移动，角规前后移动的极限距离参见本说明第 13 页；

注：角规每档的调节距离是 25 mm

600W 机柜的角规移动

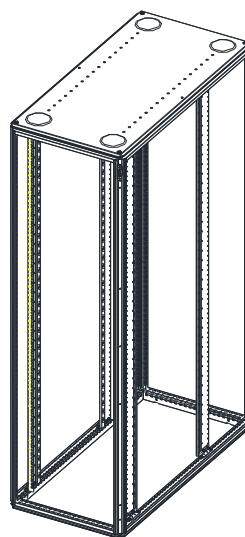
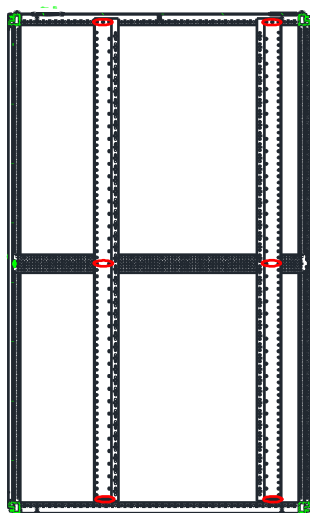

800W 机柜的角规移动

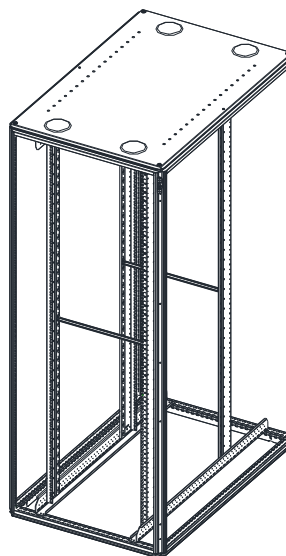
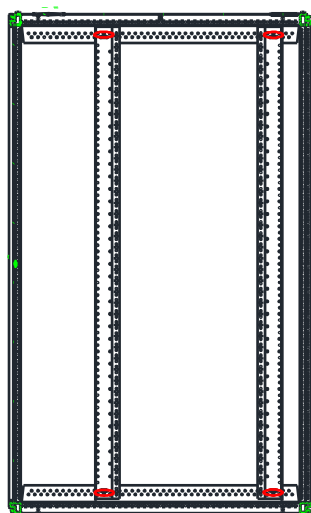

- 将图中圈内的螺丝松开
- 按箭头方向移动角规至合适距离
- 重新上紧螺丝，使角规固定
- 重复上述步骤，将其余 3 条角规移动至合适位置

6. Adjustment of the mounting angle

In order to meet the installation requirements of different depth 19 equipment, mounting Angle of the cabinet can be moved forward and backward, The limit distance of mounting angle is shown in page 13;

Note: the adjustment distance of the mounting angle gauge is 25 mm.

600w cabinet

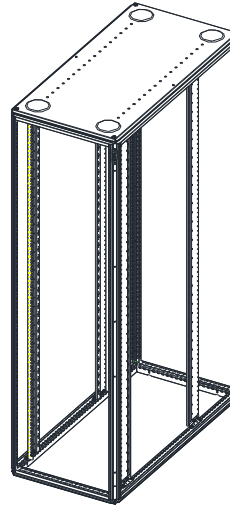
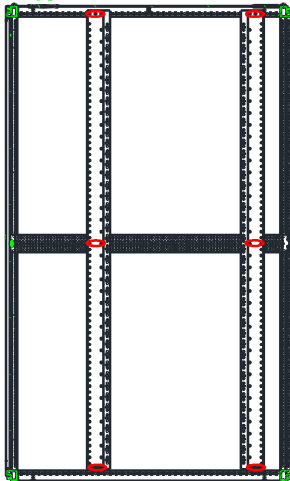

800w cabinet

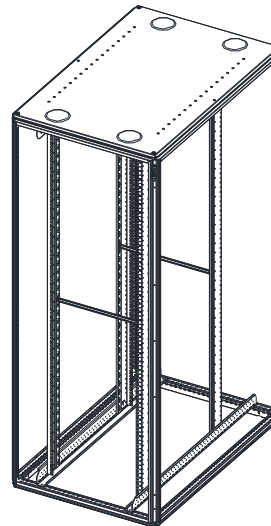
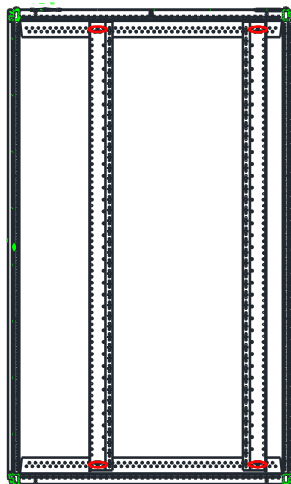

Loosen the screws in the circle.

- Move the mounting angle to the right position.
- Fix the screws again.
- Repeat the above steps and move the left three mounting angles to the appropriate position.

7. 机柜侧板的安装（选配件）

1. 机柜侧板的需要根据机柜高度及深度选择对应的侧板，目前可直接订货的物料号如下表

料号	英文描述	中文描述	颜色
1194470	SR IT Side panel H2000D600	SR IT 侧板 H2000D600	RAL9005 砂纹
1194471	SR IT Side panel H2000D800	SR IT 侧板 H2000D800	RAL9005 砂纹
1194472	SR IT Side panel H2000D1000	SR IT 侧板 H2000D1000	RAL9005 砂纹
1194473	SR IT Side panel H2000D1100	SR IT 侧板 H2000D1100	RAL9005 砂纹
1194474	SR IT Side panel H2000D1200	SR IT 侧板 H2000D1200	RAL9005 砂纹
1194475	SR IT Side panel H2200D1000	SR IT 侧板 H2200D1000	RAL9005 砂纹
1194476	SR IT Side panel H2200D1100	SR IT 侧板 H2200D1100	RAL9005 砂纹
1194477	SR IT Side panel H2200D1200	SR IT 侧板 H2200D1200	RAL9005 砂纹

2. 机柜侧板的安装

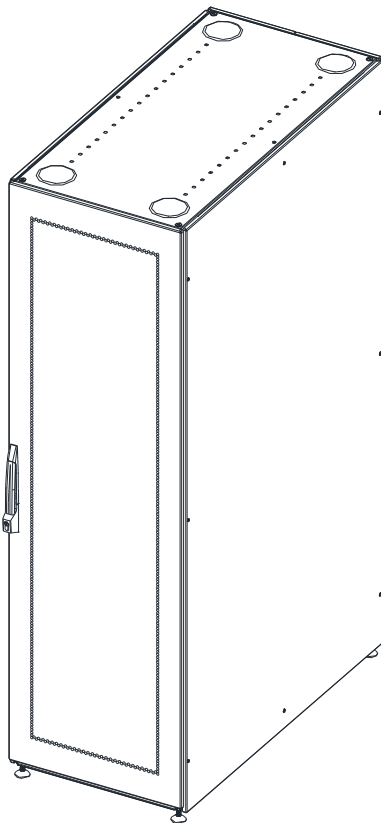

安装步骤1：将侧板固定销固定框架上；

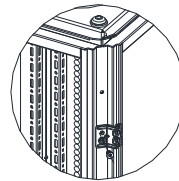

安装步骤2：将侧板固定在固定销上；

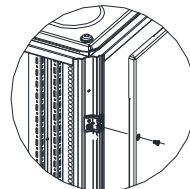

安装步骤3：当机柜深度大于等于1000时侧板中间也需要固定，内部框架上需要安装方形固定销；

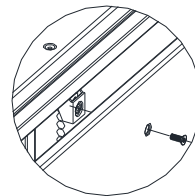

注：此类型侧板安装时至少需要两人操作；

7. Installation of Sidepanels(optional accessory)

1.Side panles are selected according to the height and depth of the cabinet.The following is the standard material number that can be ordered directly.

material number	English description	Chinese description	color
1194470	SR IT Side panel H2000D600	SR IT 侧板 H2000D600	RAL9005sandtxt
1194471	SR IT Side panel H2000D800	SR IT 侧板 H2000D800	RAL9005sandtxt
1194472	SR IT Side panel H2000D1000	SR IT 侧板 H2000D1000	RAL9005sandtxt
1194473	SR IT Side panel H2000D1100	SR IT 侧板 H2000D1100	RAL9005sandtxt
1194474	SR IT Side panel H2000D1200	SR IT 侧板 H2000D1200	RAL9005sandtxt
1194475	SR IT Side panel H2200D1000	SR IT 侧板 H2200D1000	RAL9005sandtxt
1194476	SR IT Side panel H2200D1100	SR IT 侧板 H2200D1100	RAL9005sandtxt
1194477	SR IT Side panel H2200D1200	SR IT 侧板 H2200D1200	RAL9005sandtxt

2. Installation of Sidepanels

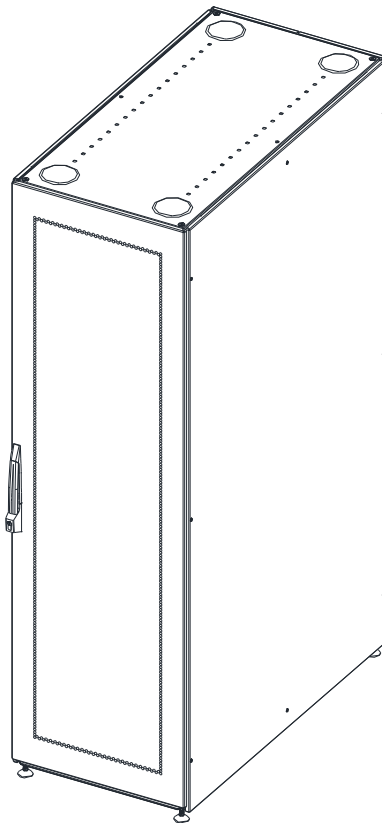

Step1:fix the fixing braket to frame

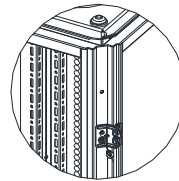

Step2:fix the side panels to the fixing braket

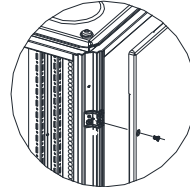

Step3: When the cabinet depth is greater than 1000, the center also needs to be fixed.

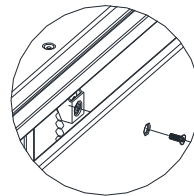

Note: When installation, it will need at least 2 people work together;

8. L 型托架的安装（选配件）

1.L 托架长度需要根据机柜内部前后角规距离进行选择，每对托架静态承重 80kg，目前可直接订货的物料号如下表

料号	英文描述	中文描述
1194490	SR IT L bracket for 345 depth	SR IT L 托架用于前后角规距离 345
1194491	SR IT L bracket for 545 depth	SR IT L 托架用于前后角规距离 545
1194492	SR IT L bracket for 645 depth	SR IT L 托架用于前后角规距离 645
1194493	SR IT L bracket for 745 depth	SR IT L 托架用于前后角规距离 745

2.L 托架尺寸

料号	托架尺寸 (42mm*57mm*Tmm)
1194490	42*57*275
1194491	42*57*475
1194492	42*57*575
1194493	42*57*675

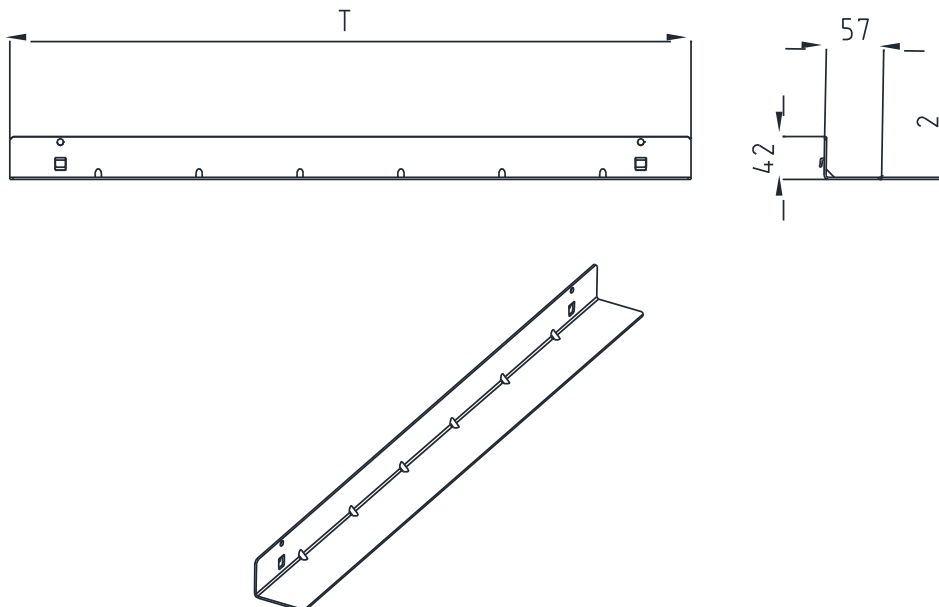

8. Installation of slide rails(optional accessory)

1.The length of slide rails shall be selected according to the distance of the mounting angle ,the Static load for one pair slide rails is 80kg,The following is the standard material number that can be ordered directly.

material number	English description	Chinese description
1194490	SR IT L bracket for 345 depth	SR IT L 托架用于前后角规距离 345
1194491	SR IT L bracket for 545 depth	SR IT L 托架用于前后角规距离 545
1194492	SR IT L bracket for 645 depth	SR IT L 托架用于前后角规距离 645
1194493	SR IT L bracket for 745 depth	SR IT L 托架用于前后角规距离 745

2.Dimention of slide rail

material number	Dimention (42mm*57mm*Tmm)
1194490	42*57*275
1194491	42*57*475
1194492	42*57*575
1194493	42*57*675

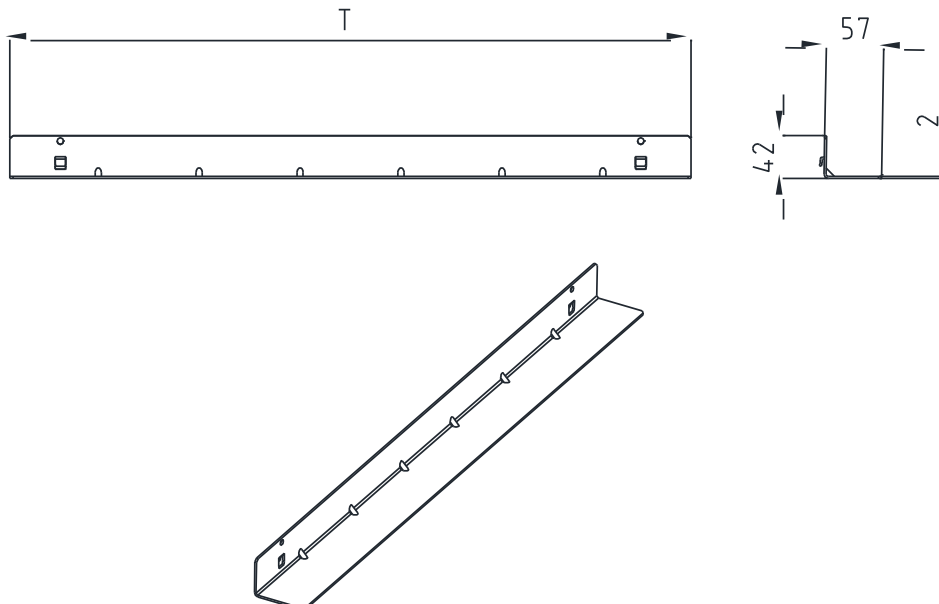

3. 安装步骤（备注：威图标准物料每对托架内含 4EA5.5*13 自攻钉）

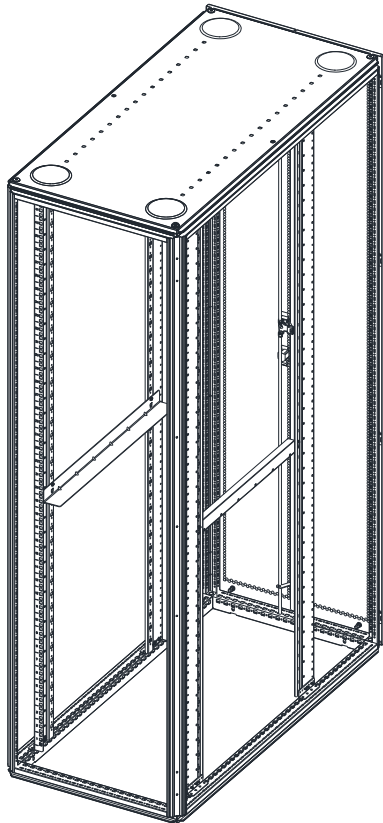

安装步骤1：将L型托架卡钩卡入对应角规侧面长方孔处

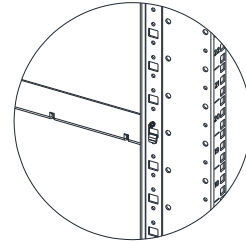

安装步骤2：用5.5×13自攻钉从内侧固定

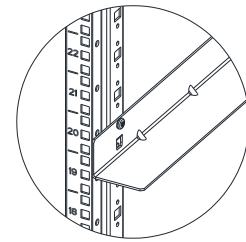

安装步骤3：安装完成

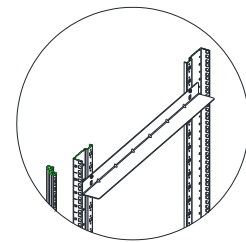

3.installation steps (note: Each pair of slide rails contains 4ea 5.5*13 self-tapping screws.)

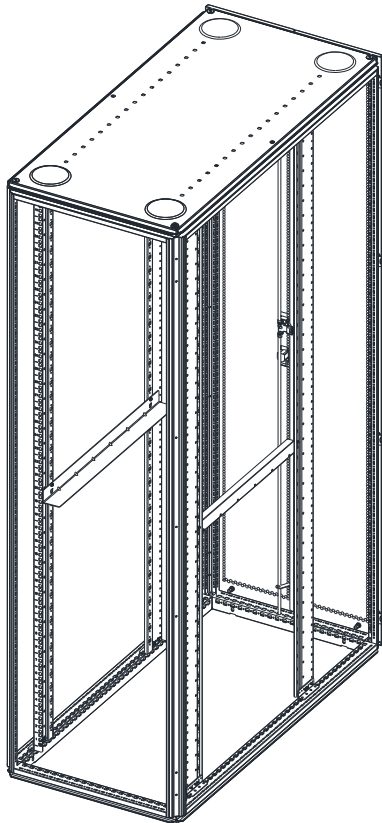

Step1:Insert the slide bracket to the side square of the mounting angle.

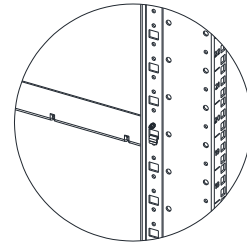

Step2:fix slide rail with 5.5*13 screws

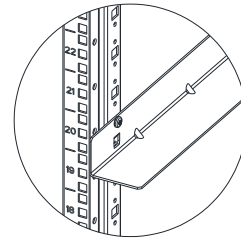

Step3:finished

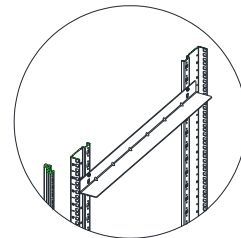

9. 固定层板的安装（选配件）

1.固定层板深度尺寸需要根据机柜内部前后角规距离进行选择，层板静态承重 100kg，目前可直接订货的物料号如下表。

料号	英文描述	中文描述	颜色
1194484	SR IT Shelf for 345 depth	SR IT 承板 用于前后角规距离 345	电泳 RAL9017
1194485	SR IT Shelf for 545 depth	SR IT 承板 用于前后角规距离 545	电泳 RAL9017
1194486	SR IT Shelf for 645 depth	SR IT 承板 用于前后角规距离 645	电泳 RAL9017
1194487	SR IT Shelf for 745 depth	SR IT 承板 用于前后角规距离 745	电泳 RAL9017

2.固定层板尺寸

料号	层板尺寸 (489mm*Tmm)
1194484	489*275
1194485	489*475
1194486	489*575
1194487	489*675

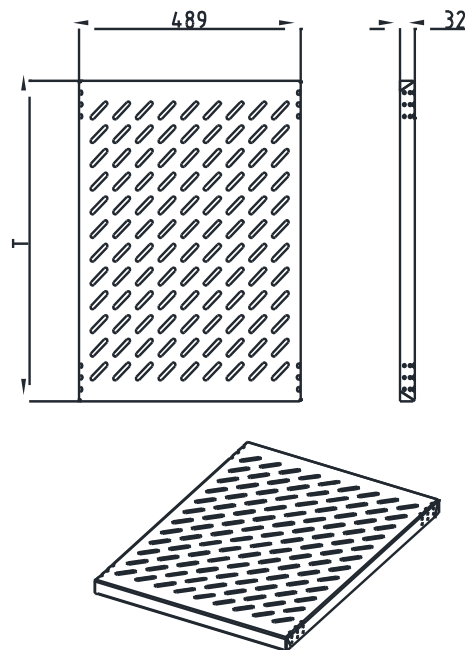

9. Installation of static shelf(optional accessory)

1. The length of shelf shall be selected according to the distance of the mounting angle ,the Static load of shelf is 100kg,The following is the standard material number that can be ordered directly.

material number	English description	Chinese description	color
1194484	SR IT Shelf for 345 depth	SR IT 承板 用于前后角规距离 345	Ecoat ral9017
1194485	SR IT Shelf for 545 depth	SR IT 承板 用于前后角规距离 545	Ecoat ral9017
1194486	SR IT Shelf for 645 depth	SR IT 承板 用于前后角规距离 645	Ecoat ral9017
1194487	SR IT Shelf for 745 depth	SR IT 承板 用于前后角规距离 745	Ecoat ral9017

2.Dimention of shelf

material number	Dimention (489mm*Tmm)
1194484	489*275
1194485	489*475
1194486	489*575
1194487	489*675

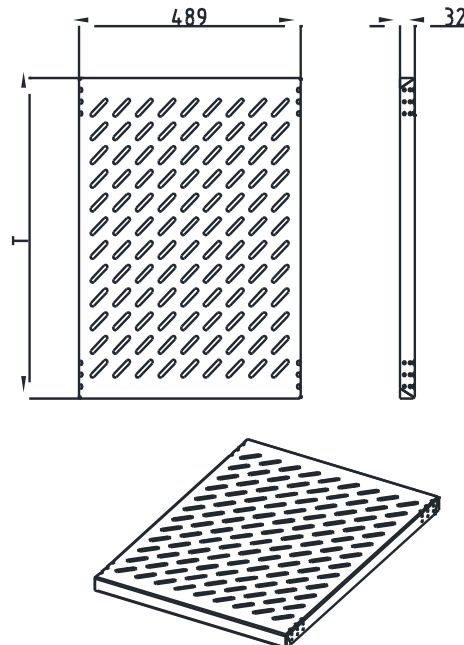

3. 安装步骤（备注：威图标准物料每块层板内含 4EA5.5*13 自攻钉）

安装步骤1：将层板对准需要安装的位置，
并在内部4角部安装5.5×13自攻钉；

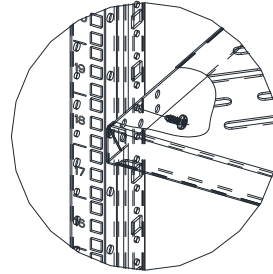
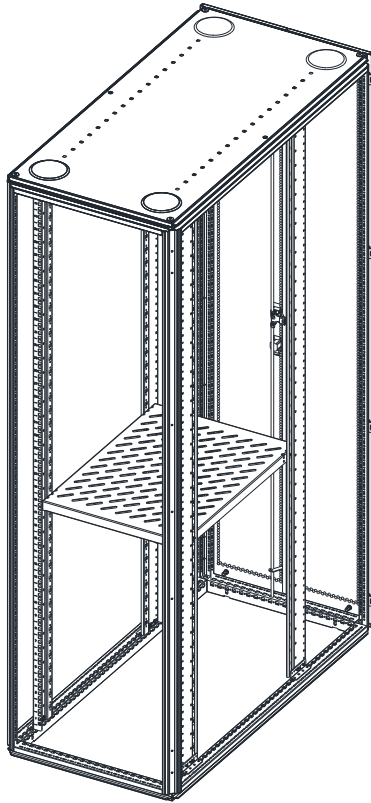

安装步骤2：安装完成。

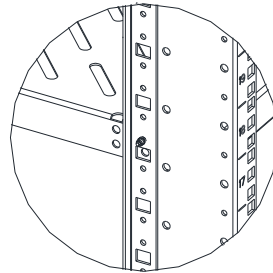

3.installation steps (note: Each shelf contains 4ea 5. 5*13 self-tapping screws.)

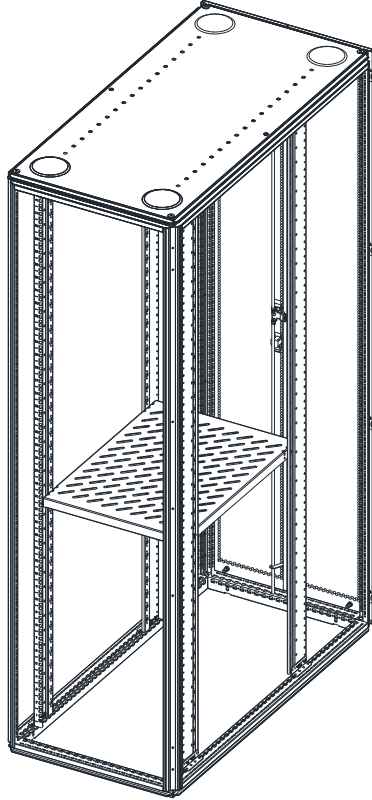

Step1:fix shelf with 5.5*13 screws

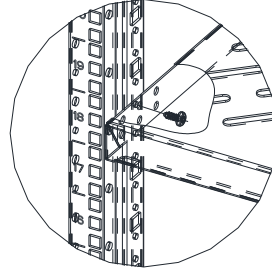

Step2:finished

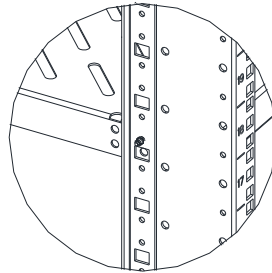

4.对于已选择好固定层板的用户可以根据设备深度尺寸适当调整机柜前后角规距离,已有层板依然可以安装;各种类层板对应的角规适配距离如下表

料号	适配角规前后距离 (mm)
1194484	295、345、395
1194485	495、545、595
1194486	595、645、695
1194487	695、745、795

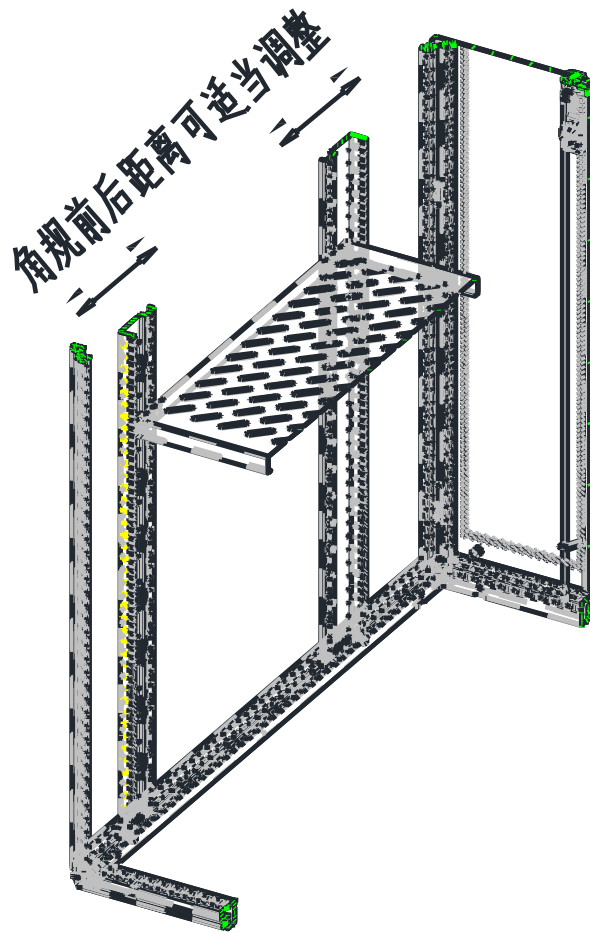

4. For users who have selected shelf already, they can adjust the distance of mounting angle , and the existing shelf can still be installed,The following table is the appropriate distance for each shelf.

material number	Distance between front and rear mta (mm)
1194484	295、345、395
1194485	495、545、595
1194486	595、645、695
1194487	695、745、795

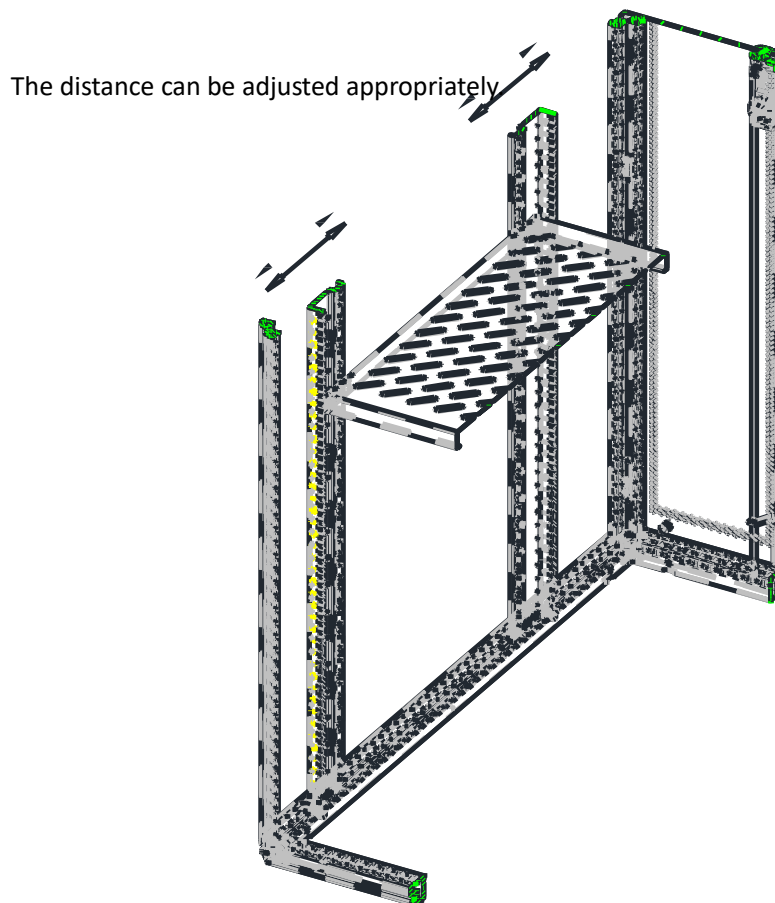

10. 左右分段式底板的安装

- 左右分段式底板可根据机柜宽度及深度选择对应大小的尺寸底板，威图左右分段式底板带 4 个直径 110 的过线孔，并且在机柜并柜后也可以安装，目前可直接订货的物料号如下表。

料号	英文描述	中文描述	适配机柜尺寸 宽 W (mm)*深 D (mm)
1194494	SR IT base plate W600D600	SR IT 底板 W600D600	600*600
1194495	SR IT base plate W600D800	SR IT 底板 W600D800	600*800
1194496	SR IT base plate W600D1000	SR IT 底板 W600D1000	600*1000
1194497	SR IT base plate W600D1100	SR IT 底板 W600D1100	600*1100
1194498	SR IT base plate W600D1200	SR IT 底板 W600D1200	600*1200
1194499	SR IT base plate W800D600	SR IT 底板 W800D600	800*600
1194500	SR IT base plate W800D800	SR IT 底板 W800D800	800*800
1194501	SR IT base plate W800D1000	SR IT 底板 W800D1000	800*1000
1194502	SR IT base plate W800D1100	SR IT 底板 W800D1100	800*1100
1194503	SR IT base plate W800D1200	SR IT 底板 W800D1200	800*1200

- 左右分段式底板尺寸见下表及附图。

料号	底板尺寸宽 A (mm)*深 B (mm)
1194494	512*512
1194495	512*712
1194496	512*912
1194497	512*1012
1194498	512*1112
1194499	712*512
1194500	712*712
1194501	712*912
1194502	712*1012
1194503	712*1112

10. Installation of Base plate(optional accessory)

1. Base plate shall be selected according to the width and depth of the cabinet ,each pair base plate have 4 diameter 110 cable holes ,The following is the standard material number that can be ordered directly.

material number	English description	Chinese description	Corresponding cabinet size W (mm) *D (mm)
1194494	SR IT base plate W600D600	SR IT 底板 W600D600	600*600
1194495	SR IT base plate W600D800	SR IT 底板 W600D800	600*800
1194496	SR IT base plate W600D1000	SR IT 底板 W600D1000	600*1000
1194497	SR IT base plate W600D1100	SR IT 底板 W600D1100	600*1100
1194498	SR IT base plate W600D1200	SR IT 底板 W600D1200	600*1200
1194499	SR IT base plate W800D600	SR IT 底板 W800D600	800*600
1194500	SR IT base plate W800D800	SR IT 底板 W800D800	800*800
1194501	SR IT base plate W800D1000	SR IT 底板 W800D1000	800*1000
1194502	SR IT base plate W800D1100	SR IT 底板 W800D1100	800*1100
1194503	SR IT base plate W800D1200	SR IT 底板 W800D1200	800*1200

2.Dimention of base plate is shown in the table below.

material number	Dimention WidthA (mm) *Depth B (mm)
1194494	512*512
1194495	512*712
1194496	512*912
1194497	512*1012
1194498	512*1112
1194499	712*512
1194500	712*712
1194501	712*912
1194502	712*1012
1194503	712*1112

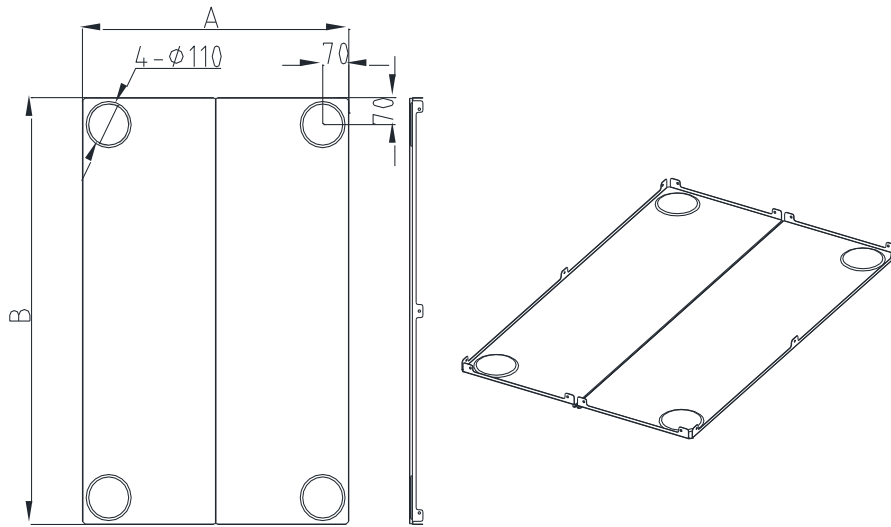

3. 左右分段式底板的安装。(备注：威图标准物料每对底板内含 14EA5.5*13 自攻钉)

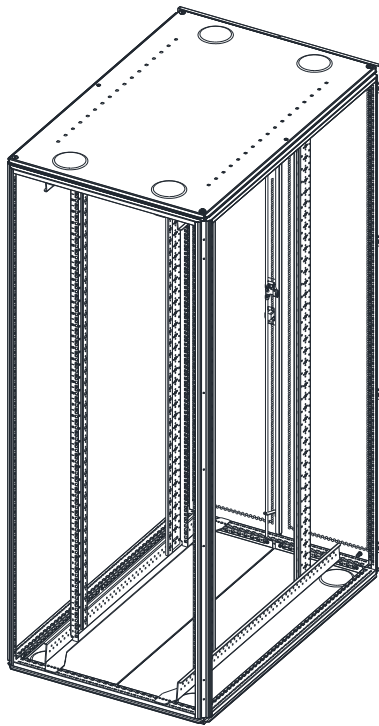

安装步骤1：先将一块底板摆放到位；

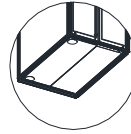

安装步骤2：用5.5×13自攻钉固定；

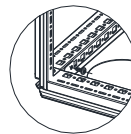

安装步骤3：再将另一块底板摆放到位并用5.5×13自攻钉固定；

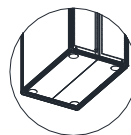

安装步骤4：用盖子把底板上孔盖住；

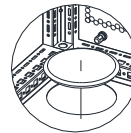

⚠ 左右分段式底板只作机柜封堵用，禁止踩踏及堆放物料；

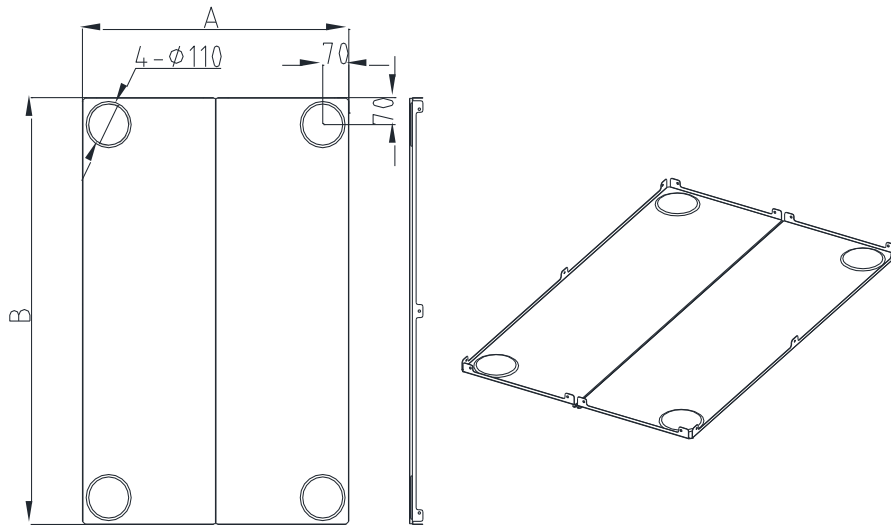

3. Installation of base plate

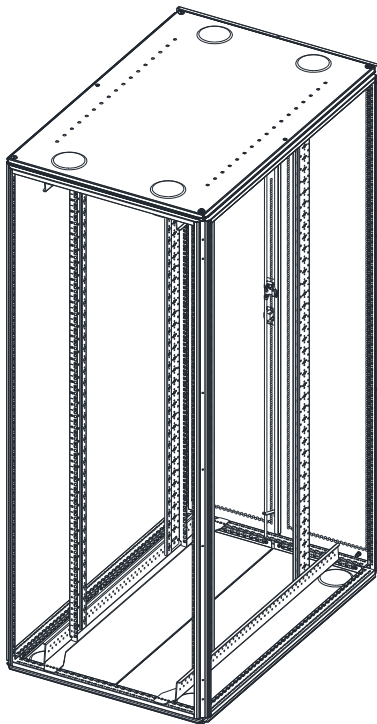

Step1: Put one base plate in place first.

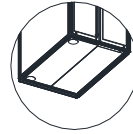

Step2: fix it with 5.5*13 screws.

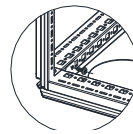

Step3: Put another base plate in place and fix it with 5.5*13 screws.

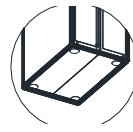

Step4: Cover the hole cover.

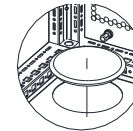

The Base plate is only used for the sealing of the cabinet, and the stamping and piling materials are prohibited.

11. 免工具 2U 盲板的安装（选配件）

1. 威图 2U 免工具安装盲板，可安装在角规 U 面任意位置，盲板采用整体注塑工艺，阻燃等级 V0，威图 2U 盲板亦可拆分成两个 1U 盲板使用。

料号	英文描述	中文描述	备注
1194506	SR IT 2U blind panel	SR IT 2U 盲板	每包 5EA

2. 免工具盲板的尺寸

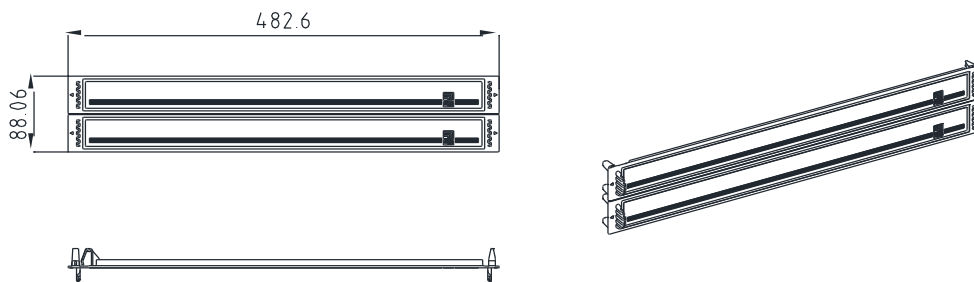

3. 免工具盲板的安装

安装步骤 1：先将盲板左侧固定销推入角规方孔内；

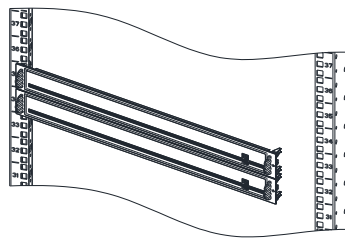

安装步骤 2：再将盲板右侧卡扣推入角规方孔内；

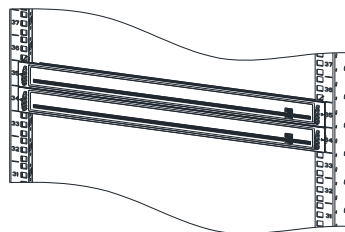

11. Installation of toolless 2U blanking panel

1. Toolless 2u blanking panel can be installed at any position in the mounting angle U surface, The blind plate adopts the whole injection molding process, the Flame retardant rating of this panel is V0, The 2U Blanking panel can also be divided into two 1U Blanking panels.

material number	English description	Chinese description	note
1194506	SR IT 2U blind panel	SR IT 2U 盲板	1PU=5EA

2. Dimension of toolless blanking panel

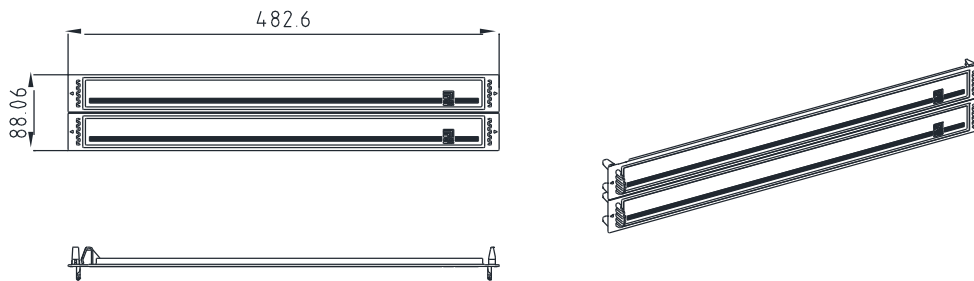

3. Installation of toolless 2U blanking panel

Step1: Push the left hook of the blanking panel into the square hole of mounting angle.

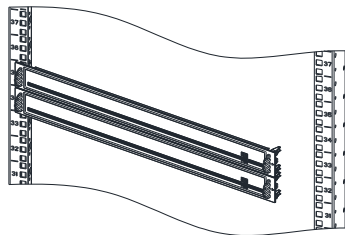

Step2: Push the right hook of the blanking panel into the square hole of mounting angle.

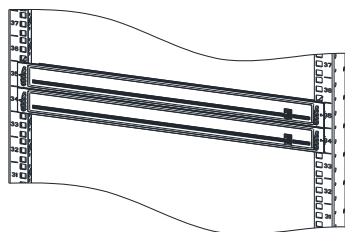

机柜参数性能

机柜描述

- 机柜内部设备安装高度 2000 高机柜 42U，2200 高机柜 47U；
- 机柜颜色：整体黑色（色标号：RAL 9005 砂纹）。
- 表面处理：门板、顶板、侧板等平板件电泳加喷涂，表面喷塑厚度达到 70-130 μm ，表面喷塑硬度应大于 2H，附着力达到 0 级国际标准，框架仅电泳色；
- 机柜钢板材质：冷轧钢板；
- 机柜承重：十六折型材框架静态承重不低于 1000 公斤；
- 机柜前：配置 1：单开网孔钢板门，通风率不小于 78%，门上配威图四点式锁杆，配舒适型手柄及安全锁芯，前门开启角度不小于 130°。

配置 2：单开钢板玻璃门，门上配威图四点式锁杆，配舒适型手柄及安全锁芯，前门开启角度不小于 130°

- 机柜后：配置 1：后对开网孔钢板门，通风率不小于 78%，门上配威图三点式锁杆，配摇把锁及安全锁芯，后门开启角度不小于 130°。

配置 2：后单开钢板门，门上配威图四点式锁杆，配舒适型手柄及安全锁芯，前门开启角度不小于 130°。

配置 3：后板。

- 每台机柜前后各配标准安装 19 英寸角规一对，位置可以前后移动，安装角规中心宽度为 465.1MM，每个“U”的位置作丝印标记，角规热镀锌板材质，不喷涂，600 宽机柜左右深度方向配有 1 对镀彩锌深度支撑，800W 机柜角规顶部及底部配有电泳黑色角规支撑。
- 机柜带有专业进出线孔，顶部、底部可分别进线。
- 相同高度及深度的机柜可以通过机柜框架与相邻的机柜框架连接固定，做并柜连接，当做并柜连接时机柜侧板需要拆除，机柜间可安装威图内嵌式隔板做分隔；
- 机柜内配有 4 套接地导线及安装螺丝，机柜门板、顶板、后板上都配有 M8 接地螺钉，用户使用时可用接地线与框架做连接；威图标准 SR IT 侧板上也配有 M8 接地钉，并带

侧板与框架连接的接地线。

Performance of cabinet parameters

Description of cabinet

- Cabinet internal equipment installation height: 2000 high cabinet 42U, 2200 high cabinet 47U;
- Color of cabinet: RAL 9005 sandtxt;
- Surface treatment: doors、top panel、side panel: ecoating+painting, The surface spraying thickness reached 70-130 μ m, The hardness of the surface is greater than 2H, Spraying adhesion to achieve level 0 international standard, frame is only ecoated in ral9017;
- Cabinet plate material: En10130-DC01;
- The load of the cabinet.: No less than 1000 kg.;
- Cabinet front: Configuration1: Single vented door, The ventilation rate is not less than 78%, The door is equipped with four point lock rod, comfort handle and safe insert, The front door open Angle no less than 130 °。

Configuration2: Single glassed door, The door is equipped with four point lock rod, comfort handle and safe insert, The front door open Angle no less than 130 °。

- Cabinet Rear: Configuration1: Double vented door, The ventilation rate is not less than 78%, The door is equipped with three point lock rod, crank lock handle and safe insert, door open Angle no less than 130 °

Configuration2: Single door, The door is equipped with four point lock rod, comfort handle and safe insert, The door open Angle no less than 130 °。

Configuration3: Rear panel。

- Each cabinet is equipped with two pairs standard 19inch mountine angles, the Position can be moved back and forth, the width of the installation mounting angle is 465.1MM, Each "U" position is marked with a silk screen, The mounting angle material is sgcc, with no

painting, 600 width cabinet equipped with one pair depth stay, 800 width cabinet equipped with top and bottom mounting angle bracket。

- The cabinet is equipped with professional entrance and outlet holes, and the top and bottom can be entered separately.
- The same height and depth cabinet can be connected each other, when buying, side panel between cabinet should be removed, The cabinet can be installed with a inner partition panel;
- The cabinet contains four grounding wires and mounting screws, The cabinet door, roof and back plate are all welded M8 earthing point, users can use wires to connect doors、roof to frame; there are also M8 earthing points on side panels, The connecting wires of SR IT standard side panel are contained。

装配清单

600W 机柜部件

序号	部件名称	数量	单位	备注
10	框架	1	个	
20	前门（前单门）	1	扇	
30	后门（后双门或后板或后单门）	1	扇	详细配置见样本
40	顶盖	1	块	
50	安装角规	2	对	
60	深度支撑	2	个	
70	机柜附件包	1	包	

800W 机柜部件

序号	部件名称	数量	单位	备注
10	框架	1	个	
20	前门（前单门）	1	扇	
30	后门（后双门或后板或后单门）	1	扇	详细配置见样本
40	顶盖	1	块	
50	安装角规	2	对	
60	角规顶部支撑	2	个	
70	角规底部支撑	2	个	
80	角规横向支撑	2	个	
90	机柜附件包	1	包	

本说明书中未尽事宜，请与 Rittal 服务工程师联系，联系电话 02151157799。

List of assembled items

600W cabinet

item	description	quantity	unit	note
10	frame	1	EA	
20	Front door	1	EA	
30	Rear door/rear panel/double door	1	EA	You can get detailed configuration from catalogue
40	Top panel	1	EA	
50	Mounting angle	4	EA	
60	Depth stay	2	EA	
70	cabinet accessory bag	1	PU	

800W cabinet

item	description	quantity	unit	note
10	frame	1	EA	
20	Front door	1	EA	
30	Rear door/rear panel/double door	1	EA	You can get detailed configuration from catalogue
40	Top panel	1	EA	
50	Mounting angle	4	EA	
60	Top bracket	2	EA	
70	Bottom bracket	2	EA	
80	Mounting angle horizontal bkt	2	EA	
90	cabinet accessory bag	1	PU	

For matters not covered in this manual, please contact Rittal service engineer at 02151157799.