

# Rittal – The System.

Faster – better – everywhere.

▶ **Micro Data Center – IT protection  
in the smallest possible space**



ENCLOSURES

POWER DISTRIBUTION

CLIMATE CONTROL

IT INFRASTRUCTURE

SOFTWARE & SERVICES

FRIEDHELM LOH GROUP



# Rittal – The System.

Faster – better – everywhere.



ENCLOSURES

POWER DISTRIBUTION

CLIMATE CONTROL

FRIEDHELM LOH GROUP

# Rittal – The System.

## Unlimited options from a single source.

For over 50 years, we have been redefining the future. We produce and develop solutions for you, our customers, covering enclosures, power distribution, climate control, IT infrastructure, software and services. The modular system architecture of our solutions enables them to be tailored to your specific needs and requirements – on a completely customised basis, depending on your industry and the size of your company, and directly from series production. We cater to a wide range of sectors – from mechanical and plant engineering and the automotive industry right through to information technology.

Based on the principle “Faster – better – everywhere”, our “Rittal – The System.” offers a perfectly coordinated system platform that combines innovative products, pioneering engineering solutions and worldwide service to meet a diverse range of requirements:

**Faster** – As a full-service provider, we help you with planning, assembly, conversion, commissioning and servicing.

**Better** – Our certified products and services are available off-the-shelf and deliver verifiable energy and cost efficiency.

**Everywhere** – Rittal offers solutions throughout the world for a variety of industries, including mechanical and plant engineering, IT and telecommunications.

IT INFRASTRUCTURE

SOFTWARE & SERVICES



# Rittal – The System.

Faster – better – everywhere.



## Micro Data Center

In addition to the physical cover in the form of an IT security safe, the configuration components listed below complement the Rittal safe and transform it into a fully fitted Micro Data Center.

- Robust, flexible racks especially for server and network technology
- Efficient cooling solutions in a range of designs and outputs
- IT-specific power distribution
- Networkable monitoring and security solutions with the CMC III system
- Early fire detection and automatic rack extinguishing



# Micro Data Center – Your benefit



- Complete solution in the smallest possible space and in next to no time
- No need for expensive upgrades to existing premises

## Level E – High level of protection for your IT

- Maximum security in the Micro Data Center product range
- Optimum protection concept for one or more server rack solutions for small and medium-sized enterprises
- Modular layout for installation in hard-to-access locations and for retrospective enclosure of existing IT structures
- Future-proof investment, thanks to the options of extendibility, dismantling and re-assembly
- System-tested security and a high level of protection; testing has been carried out by accredited test institutes and confirmed with test reports
- Modified air baffle plates for optimum air routing, for efficient cooling of the Micro Data Centers

Usable U	42/47
Usable interior depth mm	1000/1200
Fire protection	Fire resistance class F 90 to DIN 4102 Part 2, compliance with limits $\Delta T < 50$ K, rel. humidity $< 85\%$ over 30 minutes <sup>1)</sup>
Burglar resistance	RC 2 tool attack analogous to DIN EN 1630/2011-09/RC 2 <sup>4)</sup> RC 3 tool attack analogous to DIN EN 1630/2011-09/RC 3 <sup>3)</sup> WK 4 tool attack analogous to DIN V ENV 1630/1999-04/WK 4 <sup>3)</sup>
Protection category	IP 56 to IEC 60 529 <sup>4)</sup>
Smoke protection	Based on DIN 18 095-2: 1991-03 <sup>4)</sup>
Modularity	■
May be enclosed with the system operational	■
Extendibility	■

<sup>1)</sup> The Micro Data Center was tested as a system.

<sup>2)</sup> The critical connection points were tested as a system.

# Micro Data Center – Your benefit



## Level B – Solid protection for your IT

- Optimum protection concept for a server rack
- Modular layout for installation in hard-to-access locations
- Form-fit connection with the stable TS 8 framework structure
- Front and rear 482.6 mm (19") level of the TS IT rack already included with the supply
- Lower weight than the Level E Micro Data Center
- Tested security – testing has been carried out by accredited institutes and confirmed with test reports

42/47

1000/1200

Fire resistance class EI 90/F 90 to DIN EN 1363-1: 1999 / based on DIN 4102-2:1997<sup>2)</sup>

RC 2 tool attack analogous to DIN EN 1630/2011-09/RC 2<sup>3)</sup>

IP 56 to IEC 60 529: 2000<sup>3)</sup>

Based on DIN EN 1634-3: 2005-01<sup>3)</sup>

■

–

–

<sup>3)</sup> The safe for stand-alone siting was tested as a system with single-leaf doors and mechanical lock.

<sup>4)</sup> The safe for stand-alone siting was tested as a system with one single-leaf door and one bifold door and mechanical lock.

# Micro Data Center – Your added value

## Flexibility:

Modular layout, suitable even for sites that are difficult to access

## Long-term investment

**value:** Site relocations are supported, thanks to the option of re-assembly

## Physical protection:

System-tested room-within-a-room solution offers protection against fire, water, dust, smoke and external access

## Cost and time saving:

No need to upgrade the available space in the building to a server room

## Fire alarm and active

**extinguisher** for monitoring and extinguishing in the server rack

## Reliable monitoring:

Monitoring of the statuses in the server rack with the CMC III system

## Intelligent power

**distribution** with demand-based use of PDUs

**Efficient cooling** with targeted air routing and control of the server inlet temperature, inverter-regulated adjustment of the cooling output, optionally in a redundant design



# Physical security for multiple server racks



For protecting multiple server racks, we recommend buying multiple Level E Micro Data Centers. With this solution, the patch cable laid from server rack to server rack is also within the protected zone of the Micro Data Center.

## **Obsolescence-proof, thanks to extendibility**

The Micro Data Center Level E offers the option of extending the security zone at a later date by buying one or more safes. In this way, the safe expands to accommodate the growing space requirements of your IT.

## **“Pay as you grow” or expansion on demand**

There is no need to invest now for the future; you just need to keep the option of expansion open. As well as the security safe, the essential infrastructure such as cooling, power supply, monitoring and the fire alarm and extinguisher system are likewise already prepared for expansion.

# Micro Data Center Level E



**System accessories** see Cat. 35, page 613

### Applications:

- A high level of protection against potential physical threats for IT components
- Targeted configuration components transform the safe into a complete Micro Data Center

### Benefits:

- As well as facilitating installation in poorly accessible sites, the modular design also makes it possible to retrospectively enclose existing IT structures.
- Extendibility, dismantling and re-assembly mean targeted, future-safe investments
- Tested security – testing has been carried out by accredited institutes and confirmed with test reports

### Protection standards:

- Fire protection category F 90 to DIN 4102 Part 2
- Compliance with limit values  $\Delta T < 50$  K, rel. humidity  $< 85\%$  over 30 minutes
- Burglary resistance RC 2, optionally RC 3, tool attack analogous to DIN EN 1630/2011-09 and optionally WK 4, tool attack analogous to DIN V ENV 1630/1999-04/WK 2
- Smoke protection based on DIN 18 095-2: 1991-03

### Material:

- Sheet steel, coated

### Colour:

- Enclosure and service door: RAL 7035
- Operator door: RAL 9005

### Protection category IP to IEC

- 60 529:**
- IP 56

### Supply includes:

- Micro Data Center with operator door and service door
- Cable entry in both side elements
- Both doors with key lock

### Optional:

- Choice of door hinges
- Bifold doors
- Different cable entry systems
- Cable entry additionally in the top or base unit
- Different lock variants
- Supporting structure

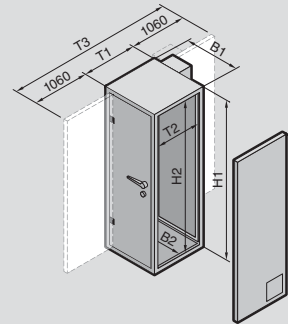

### Note:

- The Micro Data Center is configured on a project-specific basis

### Further technical information:

Available on the Internet

U		42	47	42	47
<b>External dimensions mm</b>	Width (B1)	1100	1100	1100	1100
	Height (H1)	2210	2410	2210	2410
	Depth (T1)	1200	1200	1400	1400
	Depth (T3)	3320	3320	3520	3520
<b>Internal dimensions mm</b>	Width (B2)	920	920	920	920
	Height (H2)	2030	2230	2030	2230
	Depth (T2)	1000	1000	1200	1200
<b>Model No.</b>		<b>7999.009</b>	<b>7999.009</b>	<b>7999.009</b>	<b>7999.009</b>
<b>Empty weight excluding cooling unit and excluding rack approx. kg</b>		660	700	730	800
<b>Accessories</b>					
Fire alarm and extinguisher system DET-AC/EFD III		see page 19	see page 19	see page 19	see page 19
CMC III monitoring system		see page 23	see page 23	see page 23	see page 23
PSM – Power System Module busbar		see Cat. 35, page 488	see Cat. 35, page 488	see Cat. 35, page 488	see Cat. 35, page 488
PDU – Power Distribution Unit		see page 24	see page 24	see page 24	see page 24
Compact cooling unit		see page 18	see page 18	see page 18	see page 18
LCU DX – Liquid Cooling Unit		see page 14	see page 14	see page 14	see page 14

### Standard protection from:



Fire



Extinguishing water



Corrosive gases



Vandalism



Unauthorised access



Dust



Theft/burglary

# Options Micro Data Center Level E

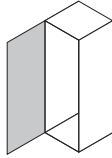
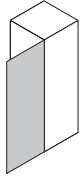
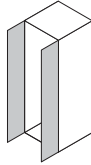
<b>Operator door</b>	L/h DIN door hinge	R/h DIN door hinge	Bifold door
			
	■	□	□

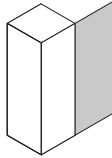
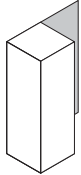
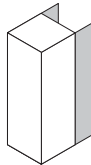

<b>Service door</b>	L/h DIN door hinge	R/h DIN door hinge	Bifold door
			
	■	□	□

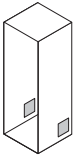
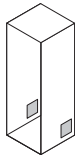
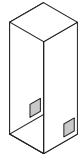
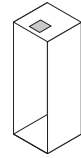
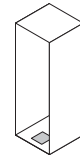
<b>Cable entry</b>	Soft duct <sup>1)</sup> in both side elements	Hard duct <sup>2)</sup> in both side elements	Cable box <sup>3)</sup> in both side elements	Hard duct <sup>2)</sup> in top element	Hard duct <sup>2)</sup> in base element
					
	■	□	□	□	□



<sup>1)</sup> Size of soft duct: approx. 267 x 165 mm  
For fire protection reasons, the duct may be configured up to a max. of 60% with cable up to a diameter of 15 mm and conduits up to a diameter of 18 mm.

<sup>2)</sup> Size of hard duct: 2 panels each 120 x 120 mm  
Cables up to a diameter of 15 mm may be routed through the hard duct.

<sup>3)</sup> Size of cable box: Field 1 approx. 210 x 44 mm, field 2 approx. 210 x 25 mm.  
Cables up to a diameter of 15 mm and hoses up to a diameter of 44 mm may be routed through the cable box.  
No conduits may be routed through the cable box.

<b>Lock systems</b>	Key lock with 2 keys	Electronic combination lock <sup>1)</sup>	Electronic combination lock for activation via an access control system supplied by the customer
	■	□	□

<sup>1)</sup> First code, second code and double code allocation possible. Key-based opening for inspection purposes supported.

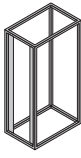
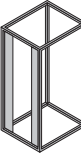

<b>TS IT rack with air baffle plates</b>								
	600				800			
Width mm								
Height mm	2000	2200	2000	2200	2000	2200	2000	2200
Depth mm	1000	1000	1200	1200	1000	1000	1200	1200
	□	□	□	□	□	□	□	□

■ Included with the supply □ Optional



<b>Supporting structure</b>	Steel supporting structure to compensate for the raised floor height when siting the Micro Data Center on the bare floor. The height of the supporting structure is selectable between 100 mm and 1000 mm.	Steel supporting structure to compensate for the raised floor height when siting the Micro Data Center on the bare floor. The supporting structure has a fire-proof covering. The height of the supporting structure is selectable between 100 mm and 1000 mm.
	□	□

■ Included with the supply □ Optional

# Micro Data Center Level B



**System accessories** see Cat. 35, page 613

### Applications:

- Basic protection against potential physical threats for IT components.
- Targeted configuration components transform the safe into a complete Micro Data Center.

### Benefits:

- Modular layout for installation in hard-to-access locations
- Lower weight than the Level E Micro Data Center
- Tested security – testing has been carried out by accredited institutes and confirmed with test reports

### Protection standards:

- Fire protection – fire resistance class EI 90/F 90 to DIN EN 1363-1: 1999 based on DIN EN 4102-2: 1997
- Burglar resistance RC 2 Tool attack analogous to DIN EN 1630/2011-09/RC 2
- Smoke protection based on DIN EN 18 1634-3: 2005-01

### Material:

- Sheet steel, coated

### Colour:

- Enclosure and service door: RAL 7035
- Operator door: RAL 9005

### Protection category IP to IEC 60 529:

- IP 56

### Supply includes:

- Security safe with integral TS 8 frame
- Front and rear 482.6 mm (19") level
- Adjusted air baffle plates
- Every side element is prepared for one cable entry at the bottom and one cable entry at the top
- Operator and service door with swing-lever handle and semi-cylinder

### Optional:

- Choice of door hinges
- Bifold doors
- Different cable entry systems
- Cable entry additionally in the top and base element
- Different lock variants
- Supporting structure with fire protection

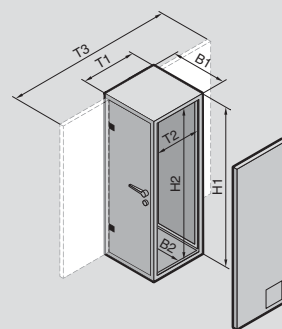

### Note:

- The Micro Data Center is configured on a project-specific basis

### Further technical information:

Available on the Internet

U		42	47	42	47
<b>External dimensions mm</b>	Width (B1)	1115	1115	1115	1115
	Height (H1)	2205	2405	2205	2405
	Depth (T1)	1377	1377	1577	1577
	Depth (T3)	3274	3274	3474	3474
<b>Internal dimensions mm</b>	Width (B2)	905	905	905	905
	Height (H2)	2000	2200	2000	2200
	Depth (T2)	1060	1060	1260	1260
<b>Model no.</b>		<b>7999.709</b>	<b>7999.709</b>	<b>7999.709</b>	<b>7999.709</b>
<b>Empty weight excluding cooling unit</b> approx. kg		595	630	660	700
<b>Accessories</b>					
Fire alarm and extinguisher system DET-AC/EFD III		see page 19	see page 19	see page 19	see page 19
CMC III monitoring system		see page 23	see page 23	see page 23	see page 23
PSM – Power System Module busbar		see Cat. 35, page 488	see Cat. 35, page 488	see Cat. 35, page 488	see Cat. 35, page 488
PDU – Power Distribution Unit		see page 24	see page 24	see page 24	see page 24
Compact cooling unit		see page 18	see page 18	see page 18	see page 18
LCU DX – Liquid Cooling Unit		see page 14	see page 14	see page 14	see page 14

### Standard protection from:



Fire



Extinguishing water



Corrosive gases



Vandalism



Unauthorised access



Dust



Theft/burglary



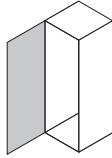
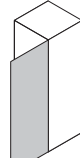
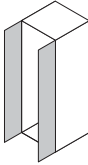

# Options Micro Data Center Level B

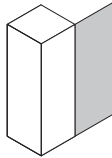
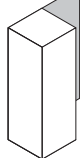
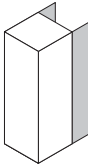
<b>Operator door</b>	L/h DIN door hinge	R/h DIN door hinge	Bifold door
			
	■	□	□

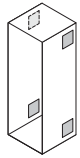

<b>Service door</b>	L/h DIN door hinge	R/h DIN door hinge	Bifold door
			
	■	□	□



<b>Cable entry</b>	Soft duct <sup>1)</sup> in both side elements	Cable box <sup>2)</sup> in top element	Cable box <sup>2)</sup> in base element	Cable box <sup>2)</sup> in both side elements
				
	■	□	□	□



<sup>1)</sup> Size of soft duct: approx. 267 x 165 mm  
For fire protection reasons, the duct may be configured up to a max. of 60% with cable up to a diameter of 15 mm and conduits up to a diameter of 18 mm.

<sup>2)</sup> Size of cable box: Field 1 approx. 210 x 44 mm, field 2 approx. 210 x 25 mm.  
Cables up to a diameter of 15 mm and hoses up to a diameter of 44 mm may be routed through the cable box.  
No conduits may be routed through the cable box.

<b>Lock systems</b>	Swing lever handle with interchangeable semi-cylinder	Swing lever handle with electronic lock for external activation	Swing lever handle with electronic lock with combination code
	■	□	□



<b>Supporting structure</b>	Steel supporting structure to compensate for the raised floor height when siting the Micro Data Center on the bare floor. The supporting structure has a fire-proof covering. The height of the supporting structure is selectable between 100 mm and 1000 mm.		
	□	□	□

■ Included with the supply □ Optional

# Liquid Cooling Unit



TS IT network/server enclosures see Cat. 35, page 100 **Micro Data Center** from page 10

## Applications:

- Cooling unit for TS IT server enclosures and for Micro Data Center

## Benefits:

- Space-saving solution by installing the internal unit in the TS IT server enclosure or the Micro Data Center
- Maximum energy efficiency due to EC fan technology and IT-based control
- Control of the server inlet temperature
- The inverter-controlled compressor adapts the cooling output to the current heat loss inside the enclosure
- Absorbed thermal energy is emitted directly to the ambient air at the (inverter-controlled) external unit's location, without heating up the installation room

## Functions:

- The device supports "front to back" air routing typical of IT applications, and regulates the server inlet temperature to the set value

## Colour:

- Internal unit: RAL 7035
- External unit: white

## Protection category IP to IEC 60 529:

- Internal unit IP 20
- External unit IP X4

## Supply includes:

- Internal unit (evaporator coil)
- External unit (inverter-controlled)
- 482.6 mm (19") mounting trim panel with display and control components
- Condensate hose

## Note:

- Below the operating limit, fluctuations in the air inlet temperature are possible
- The electrical connection is made on the external unit; the internal unit is supplied by the external unit

## Installation in TS IT:

- 482.6 mm (19") levels must be designed as mounting angles and offset in the width by 50 mm off-centre
- The front distance between the 482.6 mm (19") mounting angles and the front edge of the TS frame must be at least 100 mm
- Not suitable for combination with 482.6 mm (19") mounting frame
- Two punched sections with mounting flanges are required for attachment on the inner mounting level
- To separate the hot/cold zones within an enclosure, an air baffle plate for TS IT is required
- A Flex-Block base/plinth is required to route the cable downwards

## Further technical information:

Available on the Internet

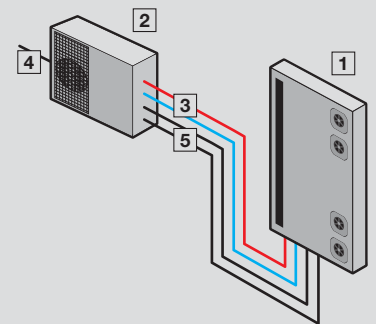

- 1 Internal unit
- 2 External unit
- 3 Refrigerant lines
- 4 Power supply
- 5 Data cable

## LCU DX, single

Model No.	Packs of	3311.490	3311.492	Cat. 35, page
<b>Useful cooling output L22 L35 kW</b>		<b>3</b>	<b>6.5</b>	
Modulation range kW		1 – 3	3 – 6.5	
For enclosure width mm		800	800	
For enclosure height mm		≥ 1800	≥ 1800	
For enclosure depth mm		≥ 1000	≥ 1000	
External unit, W x H x D mm		810 x 558 x 310	845 x 700 x 320	
Internal unit, W x H x D mm		105 x 1550 x 820	105 x 1550 x 820	
Type of electrical connection		Connection clamp	Connection clamp	
Rated operating voltage V, ~, Hz		230, 1~, 50	230, 1~, 50	
Rated current (max.) A		7	15.9	
Pre-fuse A		16	20	
Duty cycle %		100	100	
Cooling medium		R410a	R410a	
Sound pressure level at a distance of 10 m (external unit) dB(A)		40	40	
Operating temperature range (external unit)		-20°C...+45°C	-20°C...+45°C	
Weight as delivered kg		116.0	126.0	
<b>Accessories</b>				
Refrigerant lines	1 pc(s).	3311.495	3311.496	526

## Any questions about our services or maintenance agreements?

Do you need an individual, personal consultation or a service quote? Our service specialists will be happy to assist you. Please direct enquiries to the local Rittal Service organisation, either by e-mail or phone. [www.rittal.com/contact](http://www.rittal.com/contact)



**Rittal Service**

- Manufacturers' warranty
- Configuration and assembly
- Inspection
- Climate control pipework
- Commissioning
- Leak test
- Modernisation
- Maintenance
- Service agreements
- Spare parts
- Response time
- Wearing parts

# Liquid Cooling Unit



TS IT network/server enclosures see Cat. 35, page 100 Micro Data Center from page 10

## Applications:

- Cooling unit for TS IT server enclosures and for Micro Data Center in a redundant design

## Benefits:

- Space-saving solution by installing the redundantly designed internal unit in the TS IT server enclosure or the Micro Data Center
- Maximum energy efficiency due to EC fan technology and IT-based control
- Control of the server inlet temperature
- The inverter-controlled compressor adapts the cooling output to the current heat loss inside the enclosure
- Absorbed thermal energy is emitted directly to the ambient air at the (inverter-controlled) external unit's location, without heating up the installation room

## Functions:

- The redundant variants have two cooling circuits and controllers inside the internal unit, plus two inverter-regulated external units. The fault and operating hours change-over allows regular switching between the two external units, and ensures automatic changeover in the event of a malfunction or failure.
- The device supports "front to back" air routing typical of IT applications, and regulates the server inlet temperature to the set value

## Colour:

- Internal unit: RAL 7035
- External unit: white

## Protection category IP to IEC 60 529:

- Internal unit IP 20
- External unit IP X4

## Supply includes:

- Internal unit (evaporator coil)
- 2 external units (inverter-controlled)
- 482.6 mm (19") mounting trim panel with display and control components
- Condensate hose

## Note:

- Below the operating limit, fluctuations in the air inlet temperature are possible
- The electrical connection is made on the external unit; the internal unit is supplied by the external unit
- A separate power supply may be needed, depending on the external unit

## Installation in TS IT:

- 482.6 mm (19") levels must be designed as mounting angles and offset in the width by 50 mm off-centre
- The front distance between the 482.6 mm (19") mounting angles and the front edge of the TS frame must be at least 100 mm
- Not suitable for combination with 482.6 mm (19") mounting frame
- Two punched sections with mounting flanges are required for attachment on the inner mounting level
- To separate the hot/cold zones within an enclosure, an air baffle plate for TS IT is required
- A Flex-Block base/plinth is required to route the cable downwards

## Further technical information:

Available on the Internet

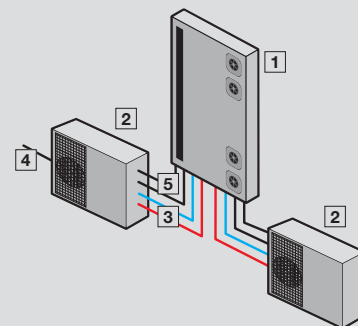

- 1 Internal unit
- 2 External unit
- 3 Refrigerant lines
- 4 Power supply
- 5 Data cable



## LCU DX, redundant

Model No.	Packs of	3311.491	3311.493	Cat. 35, page
<b>Useful cooling output L22 L35 kW</b>		<b>3</b>	<b>6.5</b>	
Modulation range kW		1 – 3	3 – 6.5	
For enclosure width mm		800	800	
For enclosure height mm		≥ 1800	≥ 1800	
For enclosure depth mm		≥ 1000	≥ 1000	
External unit, W x H x D mm		810 x 558 x 310	845 x 700 x 320	
Internal unit, W x H x D mm		105 x 1550 x 820	105 x 1550 x 820	
Type of electrical connection		Connection clamp	Connection clamp	
Rated operating voltage V, ~, Hz		230, 1~, 50	230, 1~, 50	
Rated current (max.) A		7	15.9	
Pre-fuse A		16	20	
Duty cycle %		100	100	
Cooling medium		R410a	R410a	
Sound pressure level at a distance of 10 m (external unit) dB(A)		40	40	
Operating temperature range (external unit)		-20°C...+45°C	-20°C...+45°C	
Weight as delivered kg		154.0	174.0	
<b>Accessories</b>				
Refrigerant lines	1 pc(s).	3311.495	3311.496	526

## Rittal data centre quick check – know what's going on!

On request, as part of a maintenance order or service agreement, we will carry out the following quick check on your data centre, free of charge:

- Perform an evaluation
- Assess the obsolescence risk
- Analyse energy efficiency
- Allow for current legislation and regulations
- Offer solutions

Please direct enquiries to the local Rittal Service organisation, either by e-mail or phone. [www.rittal.com/contact](http://www.rittal.com/contact)

# The Rittal service for your climate control!

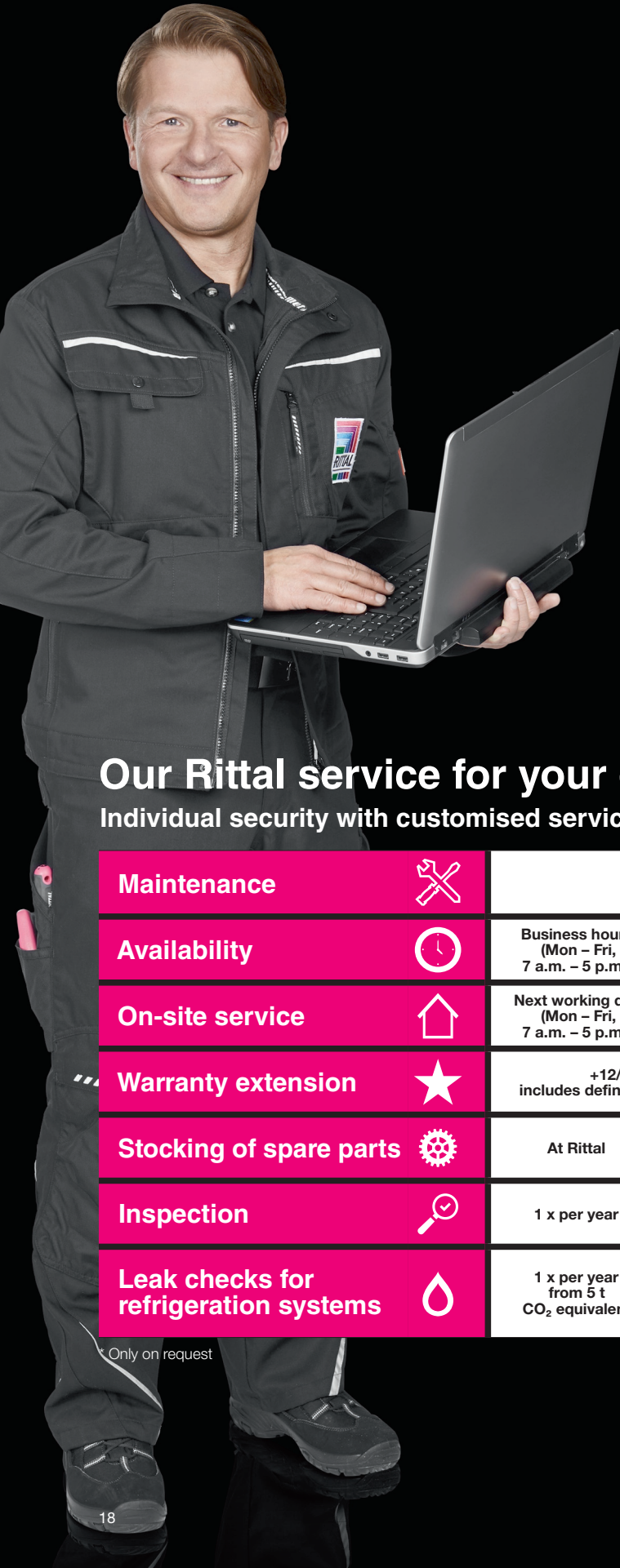

## Our expertise:







- All services from a single source
- Manufacturer expertise
- Qualified technicians with an in-depth knowledge of Rittal products and training in refrigeration engineering
- Proximity to the customer
- Short response times

## The Rittal service portfolio:

- Fast trouble-shooting
- Professional maintenance
- Configuration, assembly, installation and commissioning
- Original spare parts
- Modular service agreements
- Advice on efficiency and applications
- Modernisation

## Our Rittal service for your data centre

Individual security with customised service agreements

<b>Maintenance</b> 	1 x per year		2 x per year	
<b>Availability</b> 	Business hours (Mon – Fri, 7 a.m. – 5 p.m.)	5 x 24 hrs. (Mon – Fri)	7 x 24 hrs. (Mon – Sun)	
<b>On-site service</b> 	Next working day (Mon – Fri, 7 a.m. – 5 p.m.)	Next week day (Mon – Sat, 7 a.m. – 5 p.m.)	Within 8 hours	Within 4 hours*
<b>Warranty extension</b> 	+12/+24/+36 months, includes defined spare parts and repairs		+12/+24/+36 months, includes defined spare parts and repairs, and the preventive replacement of parts	
<b>Stocking of spare parts</b> 	At Rittal	At Rittal and delivered within 24 hours	Based on specific agreement	
<b>Inspection</b> 	1 x per year	4 x per year	12 x per year	
<b>Leak checks for refrigeration systems</b> 	1 x per year from 5 t CO <sub>2</sub> equivalent	2 x per year from 50 t CO <sub>2</sub> equivalent	4 x per year from 500 t CO <sub>2</sub> equivalent	

\* Only on request

# Fire alarm and extinguisher system



**System accessories** see Cat. 35, page 613 **TS IT network/server enclosures** see Cat. 35, page 100 **Micro Data Center** from page 10

The active extinguisher system includes the smoke extraction system and the extinguisher unit. The smoke extraction system is identical to the smoke extraction system in the EFD III. The extinguishing process begins automatically when a main alarm is activated. For the extinguishing process, the tank is pressurised via a propellant cartridge. The extinguisher gas Novec™ 1230 evaporates at the extinguisher nozzle and is distributed in the server enclosure.

#### Benefits:

- Early fire detection
- Automatic extinguishing
- Innovative extinguisher NOVEC™ 1230: eco-friendly, non-critical for IT components, non-conductive
- 482.6 mm (19") rack mount with just 1 U
- Tested by VdS Schadenverhütung GmbH
- CAN bus interface to CMC III monitoring system
- Floating relay outputs (pre-alarm/main alarm/collective fault)

#### Material:

- Sheet steel

#### Colour:

- Enclosure: RAL 7035
- Front: RAL 9005

#### Protection category IP to IEC 60 529:

- IP 30

#### Note:

- This system is designed solely for use in closed, non-accessible enclosure systems with a maximum volume of 2.8 m<sup>3</sup>.

#### Further technical information:

Available on the Internet

## DET-AC III Master

Width mm	Packs of	482.6	Cat. 35, page
Height mm		44	
Depth mm		660	
Weight kg		21.5	
<b>Model No.</b>	1 pc(s).	<b>7338.121</b>	
Operating temperature range		+10°C...+40°C	
Storage temperature range without batteries		-20°C...+65°C	
Storage temperature range of batteries		-15°C...+40°C	
Ambient humidity (non-condensing) %		96	
Rated operating voltage V, ~, Hz		100 - 240, 1~, 50/60	
Emergency power supply		approx. 4 h	
Airflow monitoring		approx. ±10% of total airflow	
Interfaces		4x/3x relay outputs for alarms and faults (terminals/RJ12 jacks) 1x/1x input for door contact switch (terminal/RJ12 jack) 2 x CAN connections for master-slave networking 2 x connection (external alarm/manual call point) 1 x voltage output for DET-AC slave III (24 V DC max. 500 mA) 1 x USB 2 x CAN bus interfaces to CMC III (max. 16 on PU/4 on PU Compact)	
Sensors		Optical smoke detector (sensitivity: approx. 3.5 %/m light obscuration) Optical smoke detector HS (sensitivity: approx. 0.25%/m light obscuration)	
Display		Plain-language display with 6 LEDs	
Technical specifications		Extinguisher is emitted via a propellant cartridge, with integral electrical activation unit Integral extinguisher monitoring (indication of >15% loss)	
Tank: Material/volume l		Aluminium / 2	
Extinguisher: Type/fill volume l		NOVEC™ 1230 / 1.8	

#### Also required

CMC III sensors	2 pc(s).	7320.530	see Cat. 35, page 550
CMC III CAN bus connection cable	1 pc(s).	7030.091	see Cat. 35, page 557
Sealing kit for TS IT and LCP	1 pc(s).	7338.135	see page 22
Pipe kit	1 pc(s).	7338.130	see page 22
Slide rails, depth-variable	2 pc(s).	5501.480	see Cat. 35, page 807

# Add-on unit



**System accessories** see Cat. 35, page 613 **TS IT network/server enclosures** see Cat. 35, page 100 **Micro Data Center** from page 10

This add-on unit to the DET AC III Master includes an additional extinguisher unit. In addition to the DET-AC III unit, a DET-AC III slave unit is used for each additional bayed enclosure and supplies the extinguishing agent for that enclosure. Detection occurs via the DET-AC III master system, even when multiple enclosures are bayed together. If a main alarm is reported, the DET-AC III Master will activate extinguishing in all systems simultaneously.

#### Benefits:

- Innovative extinguisher NOVEC™ 1230: eco-friendly, non-critical for IT components, non-conductive
- 482.6 mm (19") rack mount with just 1 U
- Tested by VdS Schadenverhütung GmbH
- CAN bus interface to CMC III monitoring system
- In conjunction with the DET-AC III Master, extinguishes up to five racks in an enclosure suite
- May be used in combination with EFD III
- Floating relay outputs (pre-alarm/main alarm/collective fault)

#### Material:

- Sheet steel

#### Colour:

- Enclosure: RAL 7035
- Front: RAL 9005

#### Protection category IP to IEC 60 529:

- IP 30

#### Note:

- This system is designed solely for use in closed, non-accessible enclosure systems with a maximum volume of 2.8 m<sup>3</sup>.

#### Further technical information:

Available on the Internet

## DET-AC III Slave

Width mm	Packs of	482.6	Cat. 35, page
Height mm		44	
Depth mm		660	
Weight kg		19.1	
<b>Model No.</b>	1 pc(s).	<b>7338.321</b>	
Operating temperature range		+10°C...+40°C	
Storage temperature range without batteries		-20°C...+65°C	
Storage temperature range of batteries		-15°C...+40°C	
Ambient humidity (non-condensing) %		96	
Rated operating voltage V		24 (DC)	
Emergency power supply		approx. 4 h	
Interfaces		4x/3x relay outputs for alarms and faults (terminals/RJ12 jacks) 1x/1x input for door contact switch (terminal/RJ12 jack) 2 x CAN connections for master-slave networking 2 x connection (external alarm/manual call point) 1 x voltage output for DET-AC slave III (24 V DC max. 500 mA) 1 x USB 2 x CAN bus interfaces to CMC III (max. 16 on PU/4 on PU Compact)	
Technical specifications		Extinguisher is emitted via a propellant cartridge, with integral electrical activation unit Integral extinguisher monitoring (indication of >15 % loss)	
Tank: Material/volume l		Aluminium / 2	
Extinguisher: Type/fill volume l		NOVEC™ 1230 / 1.8	

#### Also required

CMC III sensors	2 pc(s).	7320.530	see Cat. 35, page 550
Sealing kit for TS IT and LCP	1 pc(s).	7338.135	see page 22
Pipe kit	1 pc(s).	7338.130	see page 22
Slide rails, depth-variable	2 pc(s).	5501.480	see Cat. 35, page 807

# Early fire detection system



**System accessories** see Cat. 35, page 613 **TS IT network/server enclosures** see Cat. 35, page 100 **Micro Data Center** from page 10

The EFD III early fire detection system includes the smoke extraction system in a 482.6 mm (19") subrack with just 1 U. An integral fan continuously extracts air from the area being protected via a system of pipes. The air drawn in passes through two fire detectors. If smoke is detected, the highly sensitive detector will emit a pre-alarm, while the second detector will activate the main alarm. The fire detectors are permanently monitored for correct functioning by the evaluation and control electronics on the control card.

#### Benefits:

- Early fire detection
- 482.6 mm (19") rack mount with just 1 U
- Tested by VdS Schadenverhütung GmbH
- CAN bus interface to CMC III monitoring system
- Floating relay outputs (pre-alarm/main alarm/collective fault)

#### Material:

- Sheet steel

#### Colour:

- Enclosure: RAL 7035
- Front: RAL 9005

#### Protection category IP to IEC 60 529:

- IP 30

#### Note:

- This system is designed solely for use in closed, non-accessible enclosure systems.

#### Further technical information:

Available on the Internet

## EFD III

Width mm	Packs of	482.6	Cat. 35, page
Height mm		44	
Depth mm		490	
Weight kg		15.0	
<b>Model No.</b>	1 pc(s).	<b>7338.221</b>	
Operating temperature range		+10°C...+40°C	
Storage temperature range without batteries		-20°C...+65°C	
Storage temperature range of batteries		-15°C...+40°C	
Ambient humidity (non-condensing) %		96	
Rated operating voltage V, -, Hz		100 - 240, 1-, 50/60	
Emergency power supply		approx. 4 h	
Airflow monitoring		approx. ±10% of total airflow	
Interfaces		4x/3x relay outputs for alarms and faults (terminals/RJ12 jacks) 1x/1x input for door contact switch (terminal/RJ12 jack) 2 x CAN connections for master-slave networking 3 x connection (external alarm/manual call point/tank and fill level) 1 x voltage output for DET-AC slave III (24 V DC max. 500 mA) 1 x USB 2 x CAN bus interfaces to CMC III (max. 16 on PU/4 on PU Compact)	
Sensors		Optical smoke detector (sensitivity: approx. 3.5 %/m light obscuration) Optical smoke detector HS (sensitivity: approx. 0.25%/m light obscuration)	
Display		Plain-language display with 6 LEDs	

#### Also required

CMC III CAN bus connection cable	1 pc(s).	7030.091	see Cat. 35, page 557
Pipe kit	1 pc(s).	7338.130	see page 22
Slide rails, depth-variable	2 pc(s).	5501.480	see Cat. 35, page 807

# Fire alarm and extinguisher system

## Accessories



### Pipe kit

#### for DET-AC III/EFD III

Non-adhesive plug-in system for connecting to the DET-AC III fire alarm and extinguisher system and the EFD III early fire detection system.

#### Functions:

- The system fans continuously draw air out of the protected area via this pipe system.

#### Technical specifications:

- Diameter of plastic pipe: 18 mm internal, 22 mm external

#### Colour:

- Black

#### Supply includes:

- 3 plastic pipes @ 1 m
- T-piece
- 2 connector pieces, straight
- 4 connection brackets, 90°
- 2 end caps
- Assembly parts

Packs of	Model No.
1 pc(s).	7338.130

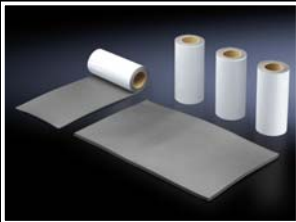

### Sealing kit for TS IT and LCP

#### In conjunction with DET-AC III master/slave

For closing openings in TS IT network/server enclosures and Liquid Cooling Packages when using a DET-AC III fire alarm and extinguisher system.

#### Applications:

- Closes 4 brush strips in the roof plate of the TS IT rack
- Closes 1 brush strip in the roof plate of the LCP
- Closes the opening in the base of the LCP CW/LCP DX in the vicinity of the refrigerant/water lines.

#### Benefits:

- Sealing of cable, hose and pipe glands in the roof and base section without impairing their function

#### Material:

- Polythene foam, self-adhesive on one side

#### Colour:

- Anthracite

#### Supply includes:

- 4 blanks to fit two TS IT roof plates
- 1 blank for an LCP

Packs of	Model No.
1 pc(s).	7338.135

# CMC III monitoring system

## CMC III monitoring system

The CMC III monitoring system controls physical parameters such as the temperature inside the Micro Data Center.

The user defines limits for the various parameters. These are fully automatically monitored by the CMC. If the limits are exceeded or undercut, the CMC emits an alarm which may optionally be notified via e-mail or SMS.

The system may also be connected to the customer network (via OPC/SNMP) to represent messages or values directly in the control room system (SCADA/BMS/NMS).

The CMC III system is plug & play-ready, sensors are detected automatically, and the Web user interface is easy to use even with no prior knowledge.

The CMC III Processing Unit Compact (basic unit) is available for small monitoring units, and supports the connection of up to four sensors. The CMC III Processing Unit for larger monitoring units supports the connection of up to 32 sensors.

There is a 24 V DC power supply with a redundant design, but power can also be supplied via the integral Power over Ethernet (PoE).

In addition to temperature monitoring, both the alarms and collective fault signal from the fire alarm and extinguishing system, as well as the fault signalling from the climate control system, may be switched to the CMC.

	Packs of	Model No.
CMC III Processing Unit Compact	1 pc(s).	<b>7030.010</b>
Power pack 100 – 240 V AC to 24 V DC	1 pc(s).	<b>7030.060</b>
Mounting unit, 1 U	1 pc(s).	<b>7030.088</b>
USB programming cable	1 pc(s).	<b>7030.080</b>
CAN bus cable 0.5 m	5 pc(s).	<b>7030.090</b>
CAN bus cable 1.0 m	1 pc(s).	<b>7030.091</b>
Temperature sensor	1 pc(s).	<b>7030.110</b>
Connection cable	1 pc(s).	<b>7200.210</b>

### Note:

Further CMC III sensors may be found on the Internet.



## Application example for monitoring a Micro Data Center with fire alarm and extinguisher system

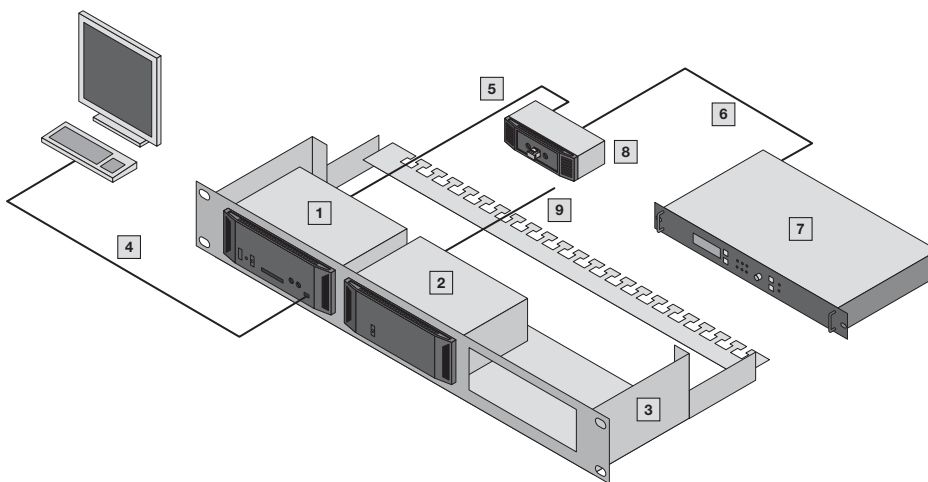

- 1 CMC III Processing Unit Compact (with front infrared access sensor, temperature sensor, 2/1 inputs/outputs)
- 2 Power pack 100 – 240 V AC to 24 V DC
- 3 Mounting unit, 1 U
- 4 USB programming cable
- 5 CAN bus connection cable 1 m
- 6 CAN bus connection cable 0.5 m
- 7 Fire alarm and extinguisher system DET-AC III
- 8 Temperature sensor
- 9 Connection cable

# Power Distribution Unit



## Power Distribution Unit

### Benefits:

- With the compact PDU, any IT rack may be easily equipped with a professional power distribution system
- With the TS IT rack, assembly is even tool-free
- Compact design
- Easy to assemble
- Power-saving design, minimal inherent consumption by the PDU itself, thanks to the use of bistable relays and OLED display with power-saving function
- Integral web server for direct network connection with extensive user administration (not PDU basic/slave PDU)
- Redundant power supply from all 3 phases and additionally via an existing PoE (Power over Ethernet) network
- Extensive range of management and monitoring functions
- High-MTBF and measurement accuracy of +/- 1%
- CAN bus for connecting slave PDUs (not PDU basic)
- Ambient monitoring with up to 4 CMC III sensors (temperature, humidity, access, vandalism)

### PDU design variants:

#### PDU basic

Robust, compact basic power distributor for the IT environment

#### PDU metered

Energy measurement per phase, i.e. output requirement of an entire IT rack

#### PDU switched

Measurement function per phase and individually switchable output slots

#### PDU managed

High-end IT rack, power distribution with energy measurement and monitoring functions for each individual output slot

#### Material:

- Extruded aluminium section, anodised

#### Protection category IP to IEC 60 529:

- IP 20

#### Standards:

- EN 60 950
- EN 61 000-4
- EN 61 000-6
- EN 55 022

#### Low Voltage Directive:

- 2014/35/EU

#### EMC directive:

- 2014/30/EU

Photo shows a configuration example with equipment not included in the scope of supply

### PDU international, basic version

Power			Pin patterns			Dimensions		Model No.
No. of phases	Phase current A	Output kW	Input	Outputs C13	Outputs C19	PDU length mm	Minimum enclosure height mm	
1	16	3.6	CEE	24	4	970	1200	<b>7955.110</b>
1	32	7.2	CEE	24	4	1115	1800	<b>7955.111</b>
3	16	11	CEE	18	3	845	1200	<b>7955.131</b>
3	16	11	CEE	24	6	1145	1800	<b>7955.132</b>
3	32	22	CEE	24	6	1365	1800	<b>7955.133</b>
3	32	22	CEE	36	6	1710	2000	<b>7955.134</b>
3	16	11	CEE	42	–	1405	1800	<b>7955.135</b>

### PDU international, metered version

Power			Pin patterns			Dimensions		Model No.
No. of phases	Phase current A	Output kW	Input	Outputs C13	Outputs C19	PDU length mm	Minimum enclosure height mm	
1	16	3.6	C20	12	–	710	1200	<b>7955.201</b>
1	16	3.6	CEE	24	4	1225	1800	<b>7955.210</b>
1	32	7.2	CEE	24	4	1370	1800	<b>7955.211</b>
3	16	11	CEE	18	3	1100	1800	<b>7955.231</b>
3	16	11	CEE	24	6	1395	1800	<b>7955.232</b>
3	32	22	CEE	24	6	1620	2000	<b>7955.233</b>
3	32	22	CEE	36	6	1965	2200	<b>7955.234</b>
3	16	11	CEE	42	–	1660	2000	<b>7955.235</b>
3	32	22	CEE	48	–	2050	2200	<b>7955.236</b>
3	63	44	CEE	12	12	19/3 U	1200	<b>7955.238</b>



# Power Distribution Unit

## PDU international, switched version

Power			Pin patterns			Dimensions		Model No.
No. of phases	Phase current A	Output kW	Input	Outputs C13	Outputs C19	PDU length mm	Minimum enclosure height mm	
1	16	3.6	C20	12	–	775	1200	<b>7955.301</b>
1	16	3.6	CEE	24	4	1360	1800	<b>7955.310</b>
1	32	7.2	CEE	24	4	1400	1800	<b>7955.311</b>
3	16	11	CEE	18	3	1180	1800	<b>7955.331</b>
3	16	11	CEE	24	6	1480	1800	<b>7955.332</b>
3	32	22	CEE	24	6	1685	2000	<b>7955.333</b>
3	32	22	CEE	36	6	2065	2200	<b>7955.334</b>
3	16	11	CEE	42	–	1755	2000	<b>7955.335</b>
3	32	22	CEE	48	–	2110	–	<b>7955.336</b>

## PDU international, managed version

Power			Pin patterns			Dimensions		Model No.
No. of phases	Phase current A	Output kW	Input	Outputs C13	Outputs C19	PDU length mm	Minimum enclosure height mm	
1	16	3.6	C20	12	–	775	1200	<b>7955.401</b>
1	16	3.6	CEE	24	4	1360	1800	<b>7955.410</b>
1	32	7.2	CEE	24	4	1400	1800	<b>7955.411</b>
3	16	11	CEE	18	3	1180	1800	<b>7955.431</b>
3	16	11	CEE	24	6	1480	1800	<b>7955.432</b>
3	32	22	CEE	24	6	1685	2000	<b>7955.433</b>
3	32	22	CEE	36	6	2065	2200	<b>7955.434</b>
3	16	11	CEE	42	–	1755	2200	<b>7955.435</b>
3	32	22	CEE	48	–	2110	–	<b>7955.436</b>

## PDU accessories

	Packs of	Model No.
Slot cover for C13 jack, lockable	10 pc(s).	<b>7955.010</b>
Slot cover for C19 jack, lockable	10 pc(s).	<b>7955.015</b>
Connector lock for C14/C20 connector	20 pc(s).	<b>7955.020</b>
TE 7000/TE 8000 PDU mounting adaptor	2 pc(s).	<b>7000.688</b>

# A data centre for Industry 4.0 requirements



“In the Micro Data Center from Rittal, we have found a solution which enables us to operate a secure, redundant data centre without having to implement any complex structural measures.”

Werner Mielenbrink, Head of Media Supply at B. Braun Avitum AG, Glandorf



Linking of 4 Micro Data Centers to protect 4 server racks

## The requirement

The experts at B. Braun, one of the world’s leading manufacturers of medical technology and pharmaceutical products, spent a long time considering how best to expand their IT landscape and at the same time make it fail-safe.

At IT component level, they wanted more virtualisation to help consolidate applications and systems, and thus enable IT resources to be used more flexibly. They also needed to find a suitable location for the servers which would protect from external access and guarantee a high level of availability.

## The solution

For its Glandorf site, B. Braun opted for the Micro Data Center Level E, a security safe for IT systems. The Micro Data Center creates a secure environment for the operation of company-critical IT. One suite for the protection of 3 server racks and another for the protection of 4 server racks each provide a complete data centre, including cooling, power distribution, monitoring and fire extinguishing.

The solution delivers the required fail-safeness and modularity for automated production to Industry 4.0.

# Rittal safeguards operations in Westerwald



The CMC III monitoring system for monitoring the statuses in the safe



IT systems of the customer installed in the 482.6 mm (19") server rack

## The requirement

The Selters community association comprises 21 municipalities with some 16,800 residents. The IT infrastructure which protects all operations within the association, as well as its own water/sewage utility, was housed in a separate IT room but was no longer able to meet security and data availability requirements.

A separate server room would have been overdimensioned for the number of servers. Eventually, at a customer event, the IT team discovered the Rittal Micro Data Center Level E.

## The solution

"The concept behind the Rittal solution and our regional proximity to the manufacturers convinced us immediately", explains Udo Koth, head of IT at the Selters community association.

The Rittal Micro Data Center Level E now ensures that the association's servers are reliably protected from physical threats such as fire, smoke, hosed water and external access.

# Rittal – The System.

Faster – better – everywhere.

- Enclosures
- Power Distribution
- Climate Control
- IT Infrastructure
- Software & Services

You can find the contact details of all Rittal companies throughout the world here.



[www.rittal.com/contact](http://www.rittal.com/contact)

XWWW00076EN1812

ENCLOSURES

POWER DISTRIBUTION

CLIMATE CONTROL

IT INFRASTRUCTURE

SOFTWARE & SERVICES



FRIEDHELM LOH GROUP