

SOLUTIONS FOR HAZARDOUS AREA APPLICATIONS

Issue 2

RITTAL & PHOENIX CONTACT INTEGRATED SOLUTIONS





Complete Hazardous Area Solutions from the World's Leading Providers

The petrochemical and mining industry demand reliability and longevity for all products. World leaders in their fields, Rittal and Phoenix Contact partner together to provide the highest quality products with unmatched customer service for hazardous area applications.

Solutions for Hazardous Area Applications provides you with a comprehensive portfolio of Rittal and Phoenix Contact solutions specifically designed for the demanding environments of the petrochemical and mining industry.

See our range of products – tried, tested and proven to be as tough as the environments they're placed in. We look forward to speaking to you about your next project.

You're in Good Company:

The world's leading DCS and PLC vendors choose Rittal and Phoenix Contact.



Rittal and Phoenix Contact:

Rittal and Phoenix Contact bring an accumulated 150 years of experience, a presence in over 60 countries, 20,000 professional staff and the highest quality engineering.

Together in Australia since 1995, Rittal and Phoenix Contact are world leaders in their field and provide a complimentary product and service solution to the Australian market. Rittal is the largest enclosure provider globally and supplies efficient climate control and power distribution. Phoenix Contact is a leading developer and manufacturer of electrical connection, electronic interface and industrial automation technologies.

With nine locations across Australia and New Zealand and a wide distribution network, Rittal and Phoenix Contact are your local, global provider of quality, German engineering.

Quality and Durability are the Outstanding Features of our Products

International standards form the basis for worldwide use in the chemical, oil and gas industry. Rittal & Phoenix Contact develop products to meet the stringent requirements of the process industry.

The key to our success is our dedication to producing reliable, high-quality products. This is not just tested on finished products, but testing is performed during every step of the production process.



ClassNK



Class 1,
Div. 2
approved



Class 1,
Div. 1
approved

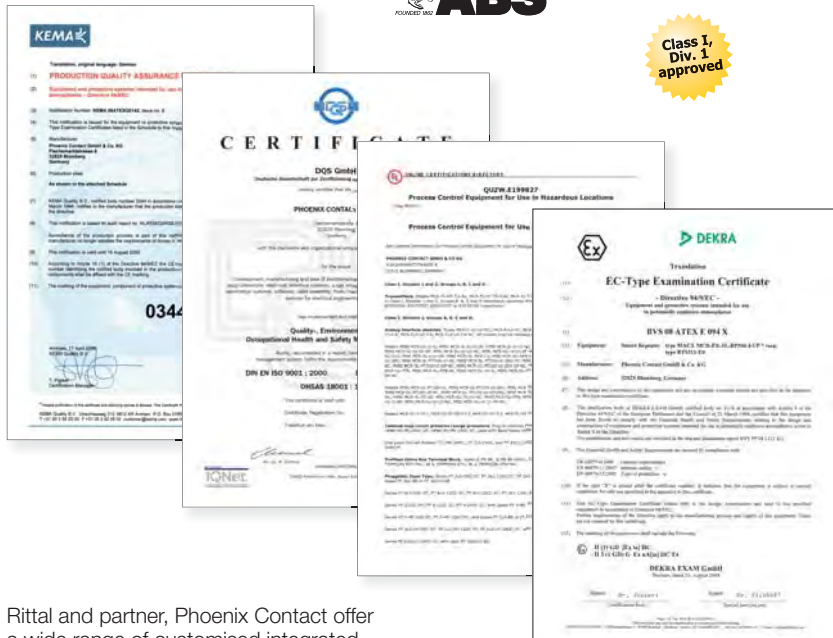

Rittal and partner, Phoenix Contact offer a wide range of customised integrated hazardous area junction box solutions. Solutions are engineered to customer specified requirements in conjunction with international hazardous area standards.



TABLE OF CONTENTS

Applications in the Chemical, Oil and Gas Industry

- Production
- Transport/Storage
- Processing

Page 4

Rittal & Phoenix Contact Capabilities

Page 6

CLIPLINE Complete for all Applications

Page 9

General Information

- Ranking of Hazard Areas
- Temperature Classes
- Labelling
- Types of Protection
- Protection Categories

Page 10

Ex Empty Enclosure

with Screw Fastened Lid
with Hinged Door

Page 15

Components for Ethernet

Page 18

Varioface System Cabling

Page 20

Components for Signal Conditioning

Page 22

Power Supply Unit - Quint Power

Page 24

Isolating Amplifiers, Surge Protection and Connection Technology for Ex i Signals

Page 26

Fibre Optic Technology for Profibus DP and Modbus

Page 28

Wireless Communication

Page 30



Hazardous Area Applications

Rittal & Phoenix Contact provide an extensive range of products engineered specifically for hazardous area applications. Rittal's range of stainless steel enclosures and hazardous area junction boxes are built to house and protect against the harshest conditions. Phoenix Contact products boast highest quality products, from the simple corrosion free terminal block to the sophisticated Ethernet switch. Phoenix Contact's power supply, signal conversion, and conditioning as well as surge protection and wireless communication provide reliable, quality solutions for you, our partners.

See our extensive portfolio of products for hazardous area applications.



Rittal and partner, Phoenix Contact offer a wide range of customised integrated hazardous area junction box solutions. Solutions are engineered to customer specified requirements in conjunction with international hazardous area standards.



Production

Tough ambient and environmental conditions require long-term maintenance free electrical and instrumentation connection points. I.e. High shock and vibration resistance. Rittal's certified range of hazardous area junction boxes provide a hard wearing solution for this environment. This tried and tested enclosure solution is combined with modular terminal blocks from Phoenix Contact, the terminal blocks are certified by independant bodies and have been proving their worth for decades.



Transport & Storage

Long distances along pipelines and in terminals do not necessarily mean long cable connections and high costs. The rugged and safe industrial "Trusted Wireless" wireless communication from Phoenix Contact enables the implementation of practical and economical solutions. Coupled with the Rittal range of hazardous area enclosures – Rittal and Phoenix Contact provide you with a secure solution for transport and storage signals.



Processing

Thousands of field signals are connected to the process control, system. Phoenix Contact provides a universal connection technology, surge protection, fast jumpering and compact signal isolation for the Ex and Non-Ex signals. Fast and economical jumpering is possible with the help of VARIOFACE system cabling with pre-assembled cables and wiring module for a variety of process control systems. Combined with Rittal's world class TS8 bayed enclosure system platform, Rittal and Phoenix Contact are the preferred supplier for the world's leading DCS and PLC vendors.

Protection for all of the above

Rittal Ex enclosures are classed as electrical components and partially certified as empty enclosures. Partial certification may only be used as a basis for overall certification of a device or protection system.

Once the enclosures have been configured with other authorised electrical, pneumatic or hydraulic components, the entire application must be certified by an accredited test body.

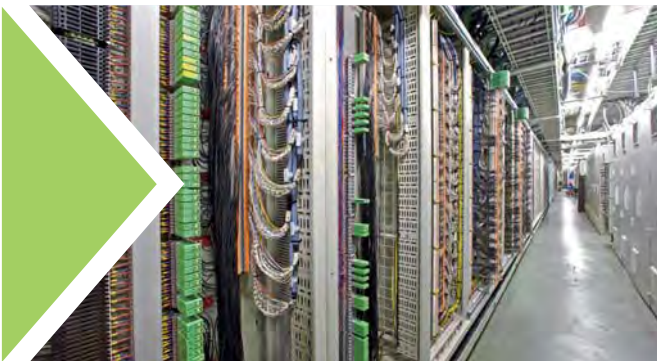
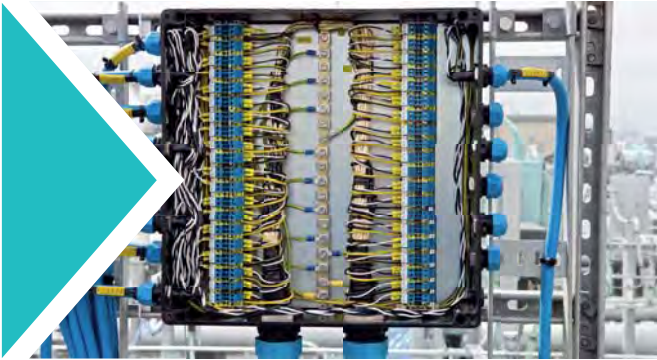

Population of enclosure with Ex components
= Individual Ex configuration

Sign-off by designated office
at the responsibility of the fitter



IEC Ex Certificate of Conformity
- IEC Ex Scheme Rules -
Equipment and Protective
Systems Intended for use in
Potentially Explosive Atmospheres

Signal Protection in Hazardous Area Field and Control Room Applications

The presentation to the right provides an overview of the following product ranges and their areas of application.

Modern Fieldbus Solutions
Via copper or fibre optic

GSM/GPRS Modems
integrate distributed data into the process control system reliably and safely

Intrinsically Safe Signal isolators
Highly compact and modular



Modular Terminal Blocks
within hazardous area junction
box for intrinsically safe circuits

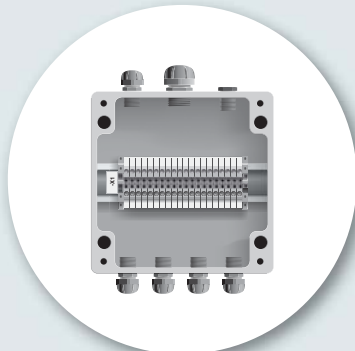

Modular Terminal Blocks
within hazardous area junction
box for intrinsically safe circuits

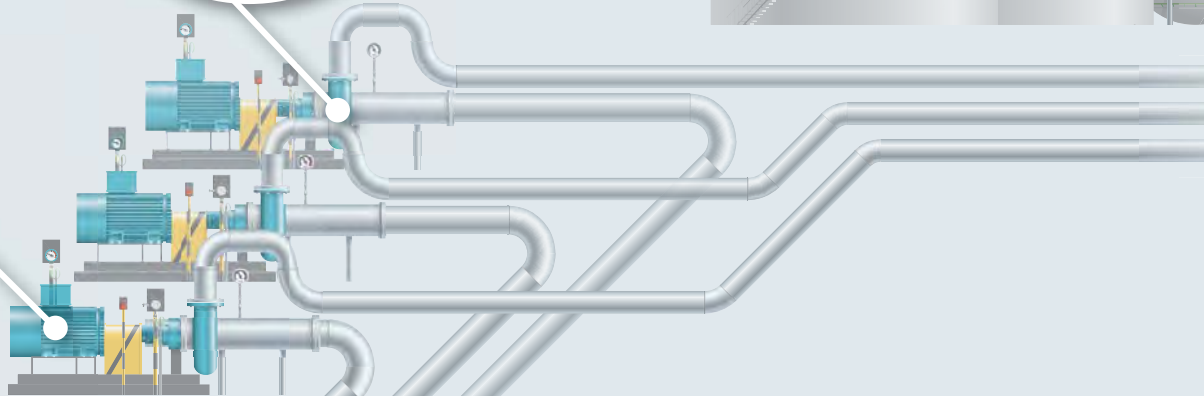
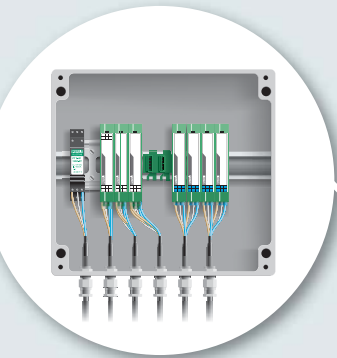
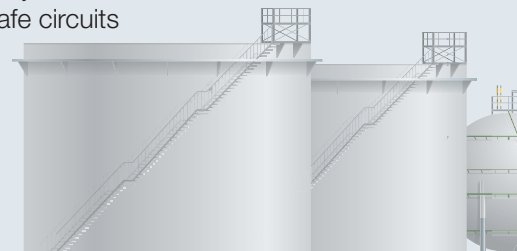

Isolation, adaption, protection
and power supply

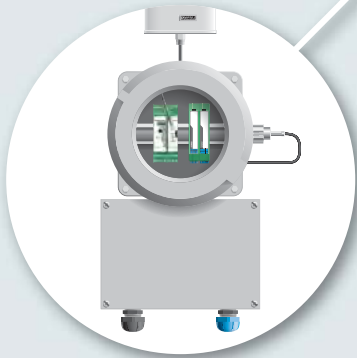
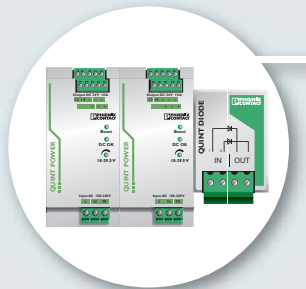

Wireless Communication
Acquiring measuring data
even in Zone 1

Ethernet
Ensures seamless
communication

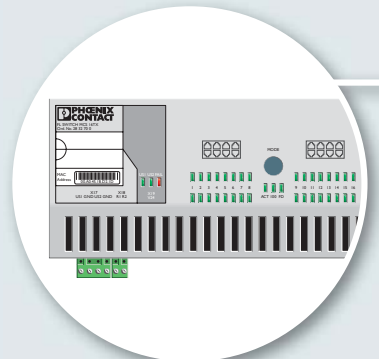

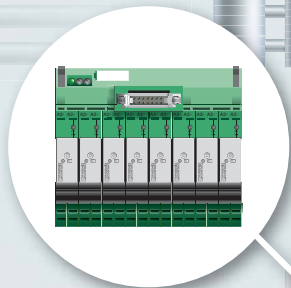
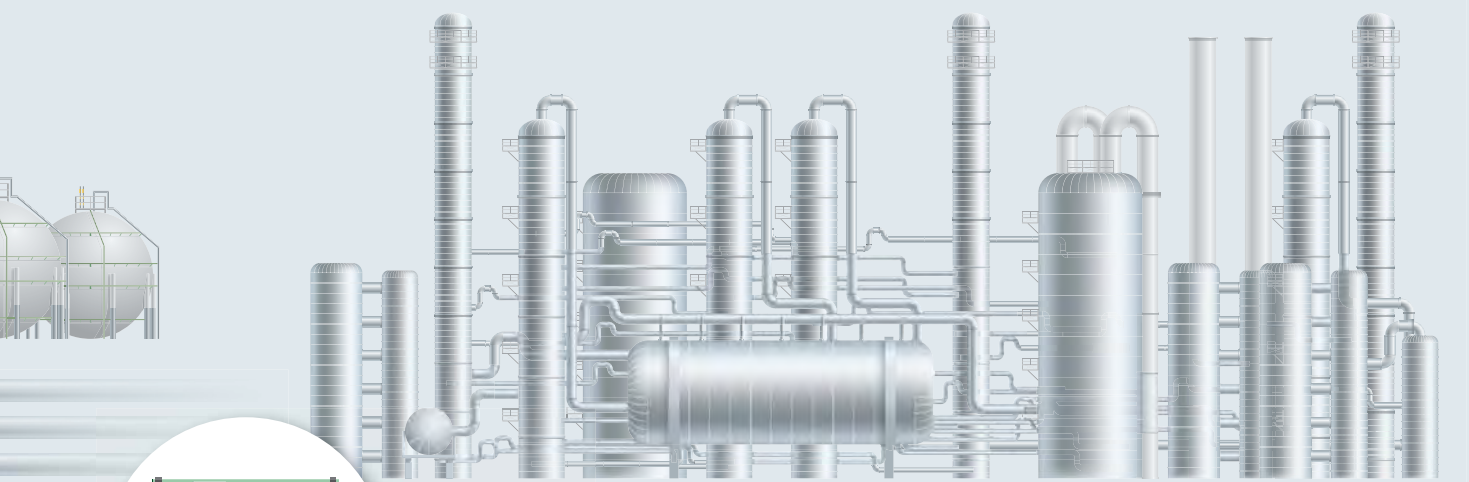

VARIOFACE System Cabling
For the inputs and outputs of the
process control system

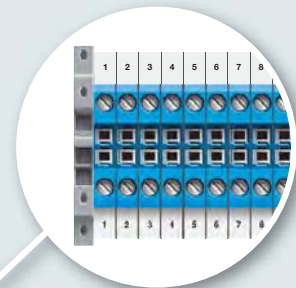

Jumpering with the
modular terminal
block system
CLIPLINE Complete

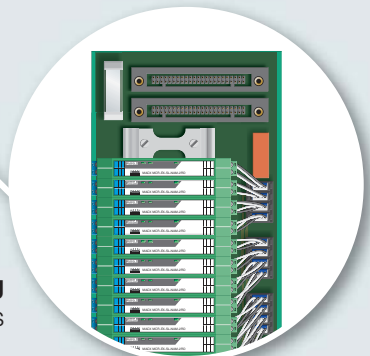
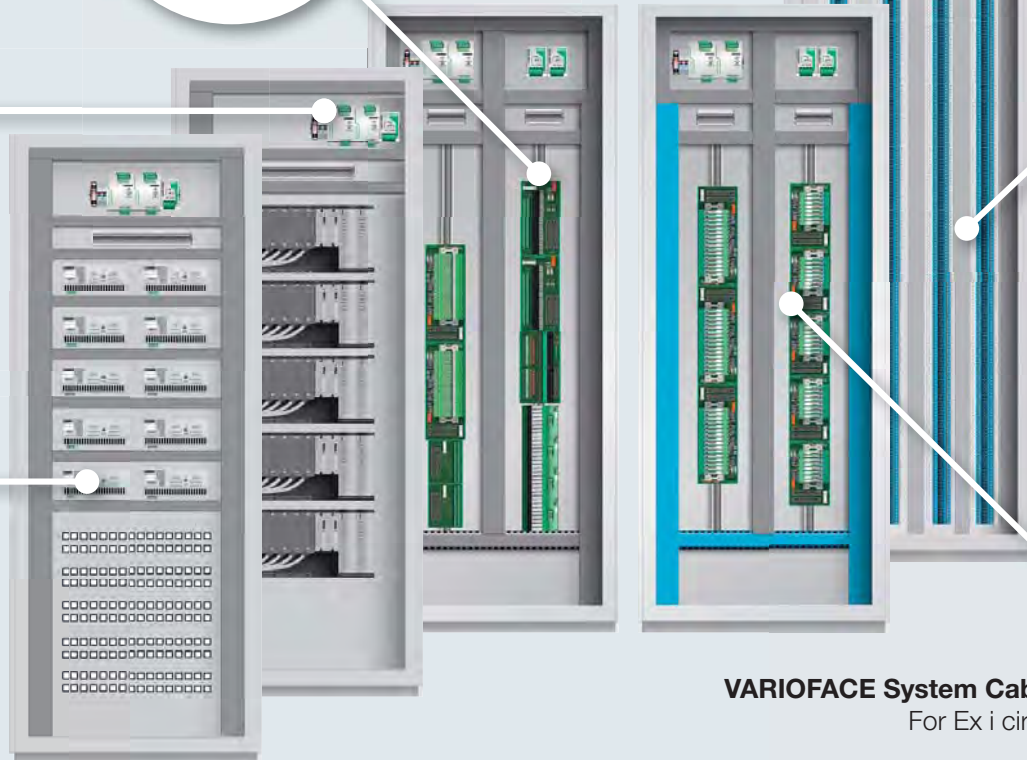

VARIOFACE System Cabling
For Ex i circuits



CLIPLINE Complete for all Applications

With the unique modular terminal block system from Phoenix Contact, the user has a choice of connection method. Whether screw, springcage, push-in, insulation displacement or ring lug connection - all of these connection systems can be combined using the same accessories, thanks to the double bridge shaft. Bridging, marking and testing accessories are standardised and reduce storage costs. The CLIPLINE complete modular terminal block system also has a large number of national and international approvals. Maximum fault tolerance is attained by means of the routine test of the standard CLIPLINE complete modular terminal blocks as per ATEX or IEC Ex, for example. The terminal blocks are maintenance-free and gas-tight; they are approved and marked for use in potentially explosive areas of Zones 1 and 2. MARKING system, the uniform solution for fast, easy and clear labeling completes this range. Regardless of whether you choose the new BLUEMARK, one of the thermal transfer printers or the plotter, a wide range of marking material is available for each printing system. This means that all forms of marking, such as the labeling of terminal blocks, conductors and equipment in and around the control cabinet can be carried out with any printer.

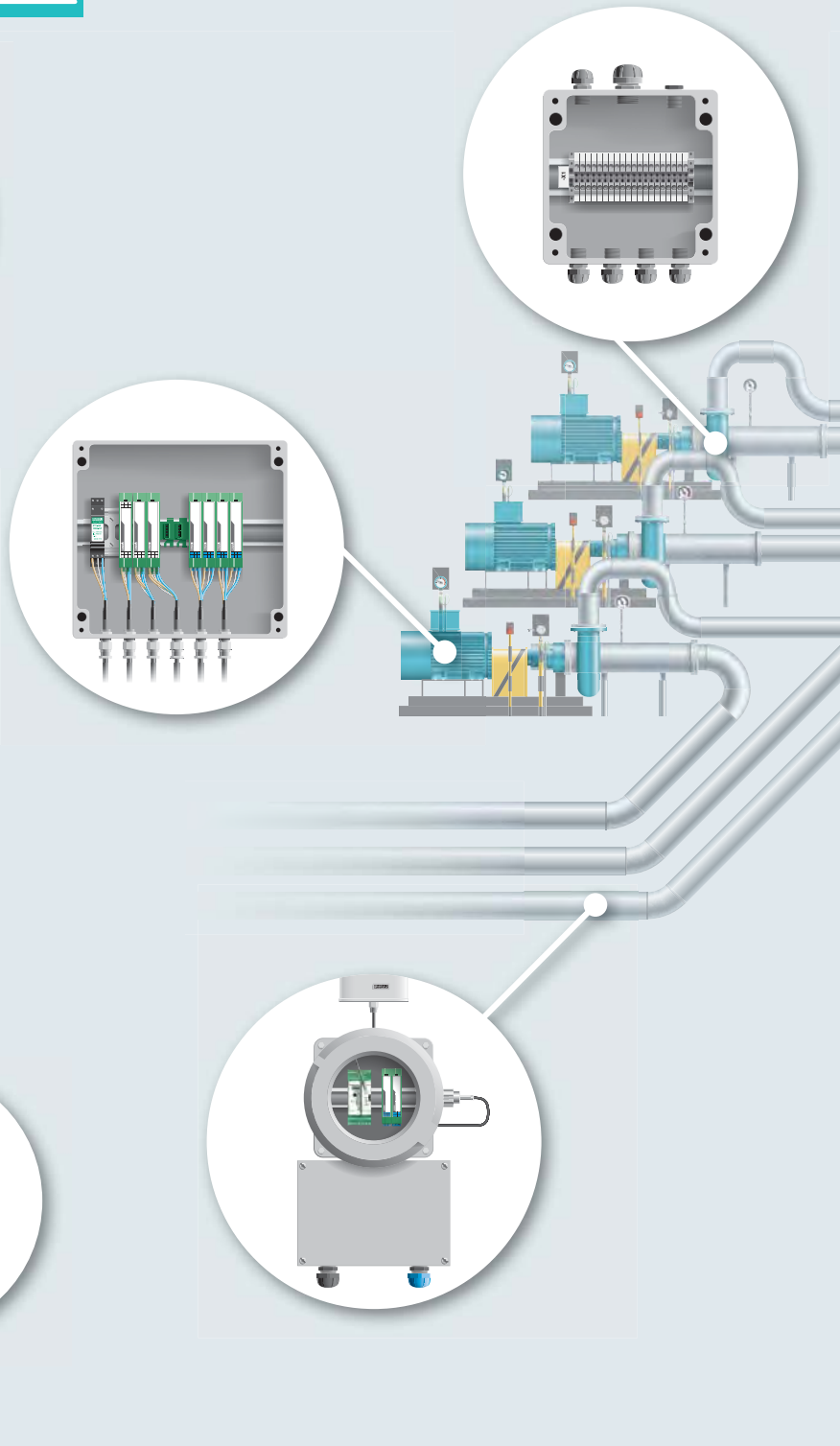

Ex e-field connection boxes with UT modular terminal blocks

General Information

A potentially explosive atmosphere is a mixture of air and flammable gases, vapours, mists or dust under atmospheric conditions in which the combustion process is transferred to the un-combusted mixture after ignition.

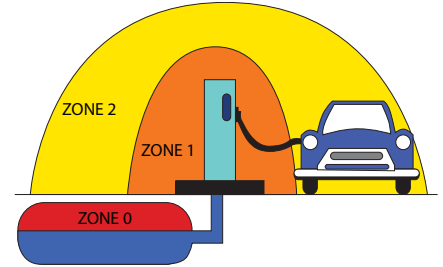
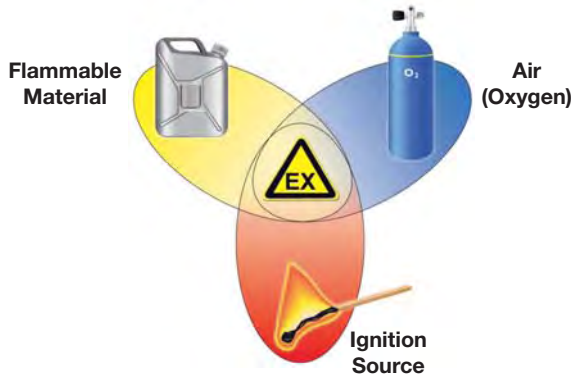

Ranking of Hazard Areas

(Zonation to EN 60079)

Atmosphere	Art of Danger (Presence of Explosive Atmosphere)	Zone
[G] Gas, vapour, mist	constantly, long periods of time, often	0
[D] Dust		20
[G] Gas, vapour, mist	occasional	1
[D] Dust		21
[G] Gas, vapour, mist	normally not, only for a short time	2
[D] Dust		22

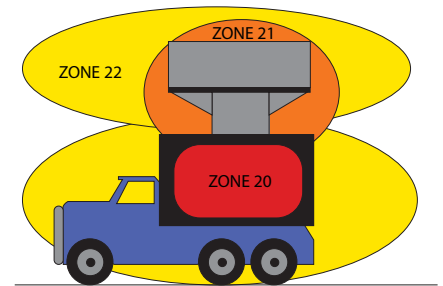

Rittal enclosures are authorised for Zone 1 and 2 [G] or 21 and 22 [D].

Temperature Classes

The temperature classes define the maximum admissible surface temperatures of the equipment.

Temperature Class	Admissible Surface Temperature
T1	> 450°C
T2	300°C
T3	200°C
T4	135°C
T5	100°C
T6	85°C

The surface temperature of the equipment / enclosure results from the ambient temperature and the self-heating.

The enclosures are suitable for use in temperature class T6.

Classification into a temperature class is made by the integrator on the basis of classification or heat dissipation of the installed components and the expected maximum ambient temperature.

Labelling

0102: Number of appointed offices
II: Equipment group
2: Equipment category
G/D: Atmosphere
eb/tb: Protection type
IIC/IIIC: Sub-group

0102	II 2 G Ex eb IIC	Ex eb IIC
	II 2 D Ex tb IIIC IP66	Ex tb IIIC IP66
Nur spannungslos öffnen / Switch off supply before removing cover		
PTB Nr./No.	Typ	Type
IEC Nr./No.	Tamb -30°C to +80 °C	
Fert.Nr. Prod.No.	Datum Date	Prüf. Test
Rittal GmbH & Co.KG D-35745 Herborn		







PTB No: No. of type-testing certified
IEC No: No. of IEC approval
Manuf. No: Consecutive serial number
Date: Date of manufacture

Type: Model number
Tamb: Temperature range (must be specified for deviations from the standard)
Insp. test: Signed by production inspector

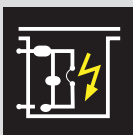
Types of Protection



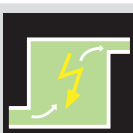
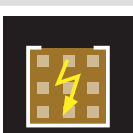

If a potentially explosive atmosphere is likely to occur despite all the precautions taken, the operating equipment used must prevent the ignition source from coming into contact with the explosive atmosphere. For this purpose, the operating equipment is qualified into protection types.

Types of protection for electrical equipment in **explosive gas** atmospheres:

Protection type	Symbol	Diagram	Principle	Applications
Flameproof enclosure	d db		Components which may ignite an explosive atmosphere are located inside an enclosure which can withstand the pressure of an explosion of the explosive mixture inside, and prevents the transmission of the explosion to the atmosphere surrounding the enclosure.	Switchgear, command devices, indicating equipment, lights, heating equipment, motors.
Intrinsic safety	ia ib ic		Intrinsically safe electrical equipment contains only circuits that meet the requirements of intrinsically safe circuits. Intrinsically safe circuits are circuits in which no spark or thermal effect occurring under the test conditions laid down in the standard can ignite the explosive atmosphere.	Sensors, actuators, measuring and control technology, fieldbus technology, information technology.
Increased safety	e eb		Additional measures provide a higher level of protection. This ensures reliable prevention of unacceptably high temperatures and sparks or electrical arcs, both on the internal and on the external parts of electrical equipment whose normal operation does not involve unacceptably high temperatures, sparks or arcing.	Terminal boxes, junction boxes, control enclosures, lights, motors, installation of Ex components (with a different type of protection).
Oil immersion	o ob		Components which might ignite an explosive atmosphere are immersed in oil or other non-flammable insulating liquid. Gasses and vapours above the oil level and outside the enclosure cannot be ignited.	Transformers, starting resistors, large switchgear.
Powder filling	q qb		By filling the enclosure with a finely grained powder an arc within the enclosure is unable, with correct use, to ignite the explosive atmosphere outside. There must be no risk of ignition by flames, nor by increased temperatures at the surface of the enclosures.	Capacitors, sensors, electronic assembly groups (components where sparks of hot surfaces occur but whose functioning is not affected by the finely grained filling).
Pressurisation	Px py px pxb pyb pzb		An ignition shield gas is used inside an enclosure at a pressure above atmospheric pressure. Thus, the ingress of the surrounding explosive atmosphere into the enclosure is prevented. If necessary, the enclosure is constantly flushed with the protective gas.	Switch and control cabinets, large motors, analytical apparatus.
Encapsulation	ma mb mc		Parts that could ignite an explosive atmosphere are encapsulated in a moulding compound to prevent ignition of the explosive atmosphere.	Switchgear of limited power, control and signalling units, display units, sensors.
Type of protection "n"	nA nC nR nAc nCc nRc		Electrical equipment cannot ignite the surrounding explosive atmosphere.	Electrical equipment for Zone 2 nA = non-sparking equipment nC = sparking devices and components nR = restricted breathing enclosure

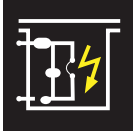
Types of Protection

Types of protection for electrical equipment in **combustible dust** atmospheres:

Protection type	Symbol	Diagram	Principle	Applications	
Intrinsic safety	ia ib ic		Intrinsically safe electrical equipment contains only circuits that meet the requirements of intrinsically safe circuits. Intrinsically safe circuits are circuits in which no spark or thermal effect occurring under the test conditions laid down in the standard can ignite the explosive atmosphere.	Sensors, actuators, measuring and control technology, fieldbus technology, information technology.	
Protection by enclosures	ta tb tc		The enclosure is sealed so tight that no combustible dust can enter or only a restricted non-dangerous amount. For this reason it is possible to install ignitable equipment in the enclosures. The surface temperature of the enclosure must not ignite the surrounding atmosphere.	Control enclosures, junction and terminal boxes, lights.	
Pressurisation	Px py px	pxb pyb pzb		An ignition shield gas is used inside an enclosure at a pressure above atmospheric pressure. Thus, the ingress of the surrounding explosive atmosphere into the enclosure is prevented. If necessary, the enclosure is constantly flushed with the protective gas.	Switch and control cabinets, large motors, analytical apparatus.
Encapsulation	ma mb mc		Parts that could ignite an explosive atmosphere are encapsulated in a moulding compound to prevent ignition of the explosive atmosphere.	Switchgear of limited power, control and signalling units, display units, sensors.	

Protection Categories

TO IEC 60 529 (EN 60 529)















The IP protection category is characterised by two numbers.

Example of protection category e.g. IP 43:

IP Code Letters

4 First Characteristic Numeral

3 Second Characteristic Numeral

Degrees of Protection for Protection Against Contact and Foreign Bodies: First Characteristic Numeral			Degrees of Protection for Protection Against Water Second Characteristic Numeral		
First Characteristic Numeral	Degree of Protection		Second Characteristic Numeral	Degree of Protection	
	Description	Explanation		Description	Explanation
	Protected against solid foreign objects with a diameter of 50 mm and greater	The object probe, a sphere 50 mm in diameter, must not penetrate fully*		Protected against vertically falling water	Vertically falling drops shall have no harmful effects.
	Protected against solid foreign objects with a diameter of 12.5 mm and greater	The object probe, a sphere 12.5 mm in diameter, must not penetrate fully* The articulated test finger may penetrate up to its length of 80 mm, but adequate distance must be adhered to		Protected against vertically falling water drops when the enclosure is tilted up to 15°	Vertically falling drops must not have any harmful effects when the enclosure is tilted up to 15° in both directions from the vertical
	Protected against solid foreign objects with a diameter of 2.5 mm and greater	The object probe, a sphere 2.5 mm in diameter, must not penetrate at all*		Protected against spraying water	Water sprayed at an angle of up to 60° on either side of the vertical must have no harmful effects
	Protected against solid foreign objects with a diameter of 1.0 mm and greater	The object probe, a sphere 1.0 mm in diameter, must not penetrate at all*		Protected against splashing water	Water splashed on the enclosure from every direction must not have any adverse effects
	Dust-protected	The ingress of dust at a partial vacuum of 20 mbar inside the enclosure		Protected against water jets	Water directed at the enclosure from every direction in a jet must not have any harmful effects
	Dust-tight	No ingress of dust at a partial vacuum of 20 mbar inside the enclosure		Protected against powerful water jets	Water directed at the enclosure from every direction in a powerful jet must not have any harmful effects
				Protected against the effects of temporary immersion in water	Water must not ingress to such an extent as to cause harmful effects when the enclosure is temporarily immersed in water under standardised pressure and time conditions
				Protected against the effects of continuous immersion in water	Water must not penetrate to such an extent as to cause adverse effects when the enclosure is permanently immersed in water under conditions which must be agreed between the manufacturer and the user. However, the conditions must be more difficult than for characteristic numeral 7
				9K**	Water directed at the enclosure from every direction under greatly increased pressure must not have any adverse effects

* The full diameter of the object probe must not pass through an opening of the enclosure.

** This test is not regulated by IEC 60529/09.2000 (EN 60 529/09.2000), but by DIN EN 40 050, part 9. Extracts from BS EN 60.259: 1991 are reproduced with the permission of BSI. Complete editions of the standards can be obtained from BSI Customer Services, 889 Chiswick High Road, London W4 4AL



Ex Empty Enclosure

with Screw Fastened Lid

Stainless Steel with Screw Fastened Lid

Facts and Features

- Captive-mounted cover attachment
- Silicone foam seal
 - Foamed-in, no joints or seams
 - Mechanically stable
 - Long-term protection against the ingress of water
- Extended ambient temperature range: -30°C to 80°C (standard: -20°C to 40°C)
- Approval for Zone 1 and 2 (gas) or 21 and 22 (dust) to ATEX and IEC

Material

- Stainless Steel 1.4301 (AISI 304)

Surface Finish

- Brushed, grain 240

Protection Category

- IP 66 to EN 60 529/09.2000



Supply Includes

- Enclosure, lid with all-round foamed-in PU seal.

System Certificate

- IECEX PTB 09.0034

Empty Enclosure Certificate

- IECEX PTB 09.0033U

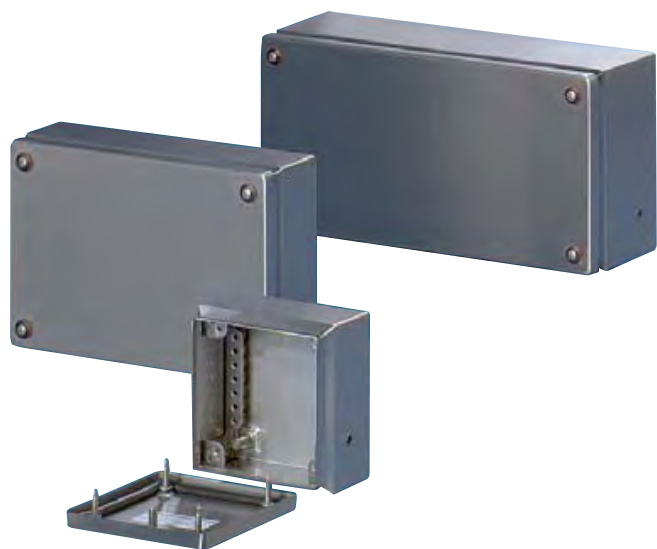

Screw-Fastened Lid 93 Series

Model No.	Width (B1) mm	Height (H1) mm	Depth mm	Mounting Plates	Weight kg
9301000	150	150	80	1560700	1.3
9303000	200	200	80	1562700	1.8
9302000	300	150	80	1561700	1.8
9304000	300	200	80	1563700	2.4
9306000	300	300	120	1567700	3.9
9305000	400	200	120	1564700	3.6

To order Ex enclosures in Stainless Steel 1.4404 (AISI 316L), please add extension .500 to the model No. Delivery times available on request.

Ex Empty Enclosure

with Hinged Door

Stainless Steel with Hinged Door

Facts and Features

- Silicone foam seal
 - Foamed-in, no joints or seams
 - Mechanically stable
 - Long-term protection against the ingress of water
- Enclosure edge fold designed as a drain channel
- Extended ambient temperature range: -30°C to 80°C (standard: -20°C to 40°C)
- Approval for Zone 1 and 2 (gas) or 21 and 22 (dust) to ATEX and IEC
[*Gland plate variants now available as standard] - BDA



Material

- Stainless Steel 1.4301 (AISI 304) or 316 on request

Mounting Plate

- Sheet Steel

Surface Finish

- Brushed, grain 240

Protection Category

- IP 66 EN 60 529/09.2000

Supply Includes

- Enclosure, door with all-round foamed-in PU seal, mounting plate.

System Certificate

- IECEx PTB 09.0036

Empty Enclosure Certificate

- IECEx PTB 09.0035U

Hinged Door 94 Series

Model No.	Width (B1) mm	Height (H1) mm	Depth mm	Width (F1) mm	Height (G1) mm	Number of Cams	Weight kg
9401600	200	300	155	162	275	1	3.8
9409600	300	380	210	334	275	1	7.7
9402600	380	300	155	334	275	1	7.4
9403600	380	380	210	334	355	1	9.7
9404600	380	600	210	334	570	2	13.3
9405600	600	600	210	549	570	2	15.6
9406600	600	760	210	549	730	2	22.3
9407600	760	760	300	704	730	2	30.5
9408600	800	1000	300	739	955	2	36.3

Ex Empty Enclosure

with Hinged Door

Plastic with Hinged Door

Facts and Features

- Double seal at top and bottom edges of the door with additional integrated rain protection strip
- Silicone foam seal
 - Foamed-in, no joints or seams
 - Mechanically stable
 - Long-term protection against the ingress of water
- Extended ambient temperature range: -30°C to 80°C (standard: -20°C to 40°C)
- Approval for Zone 1 and 2 (gas) or 21 and 22 (dust) to ATEX and IEC
- Door opening angle 180°

Material

- Enclosure: Fibreglass-reinforced unsaturated polyester
- Surface resistance: $<10^9 \Omega$
- Mounting plate: sheet steel, zinc-plated, passivated

Colour

- RAL 9011

Protection Category

- IP 66 to EN 60 529/09.2000
- KEL 9209.600: IP 56 to EN 60 529/09.2000

Supply Includes

- Enclosure, door with all-round foamed-in PU seal
- Mounting Plate

System Certificate

- IECEx PTB 10.0012

Empty Enclosure Certificate

- IECEx PTB 10.0011U

Hinged Door Fibreglass 92 Series

Model No.	Width (B1) mm	Height (H1) mm	Depth mm	Width (F1) mm	Height (G1) mm	Number of Cams	Weight kg
9201600	200	300	150	145	250	1	3.6
9202600	250	350	150	195	300	1	4.6
9203600	300	400	200	245	350	2	6.0
9204600	400	400	200	345	350	2	6.5
9205600	400	600	200	345	550	2	11.5
9207600	500	500	300	417	450	2	12.9
9206600	600	600	200	545	550	2	15.9
9208600	600	800	300	517	750	*	24.3
9209600	800	1000	300	717	950	*	39.0

* 3-point lock system

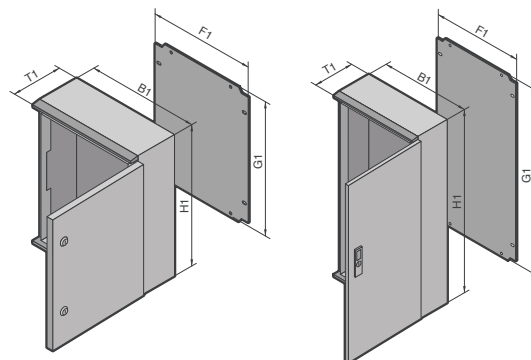

Components for Ethernet

Flexible Switch Technology

Managed switches minimise installation and maintenance time. With the increasing use of switches in process automation, demands made by users on network components are also increasing. High data throughput, network diagnostics, security functions and redundancy have been implemented.

Reliable Industrial Wireless Solutions

Our access points can be easily integrated into the Ethernet networks and are based on the industry-optimised mainstream technologies of Bluetooth and WLAN 802.11 a/b/g.

Communicative Media Converters

Our media converters convert the twisted pair interface to polymer, HCS and glass fibres in order to increase the immunity to interference and the transmission range.

Pre-Assembled Cabling Systems

An installation concept based on RJ45, M12 and SCRJ plugs with IP20 and IP67 degrees of protection and all common cable types for indoor and outdoor installation complete this product range.

Effective Surge Protection

Power supply units, I/O components and the Ethernet connections are effectively protected against surge voltages using protective adapters and lightning arresters.

Patch Fields For The Future

Patch fields provide support during high-quality on-site assembly of Ethernet networks by providing connection elements for various transmission mediums and port locks.

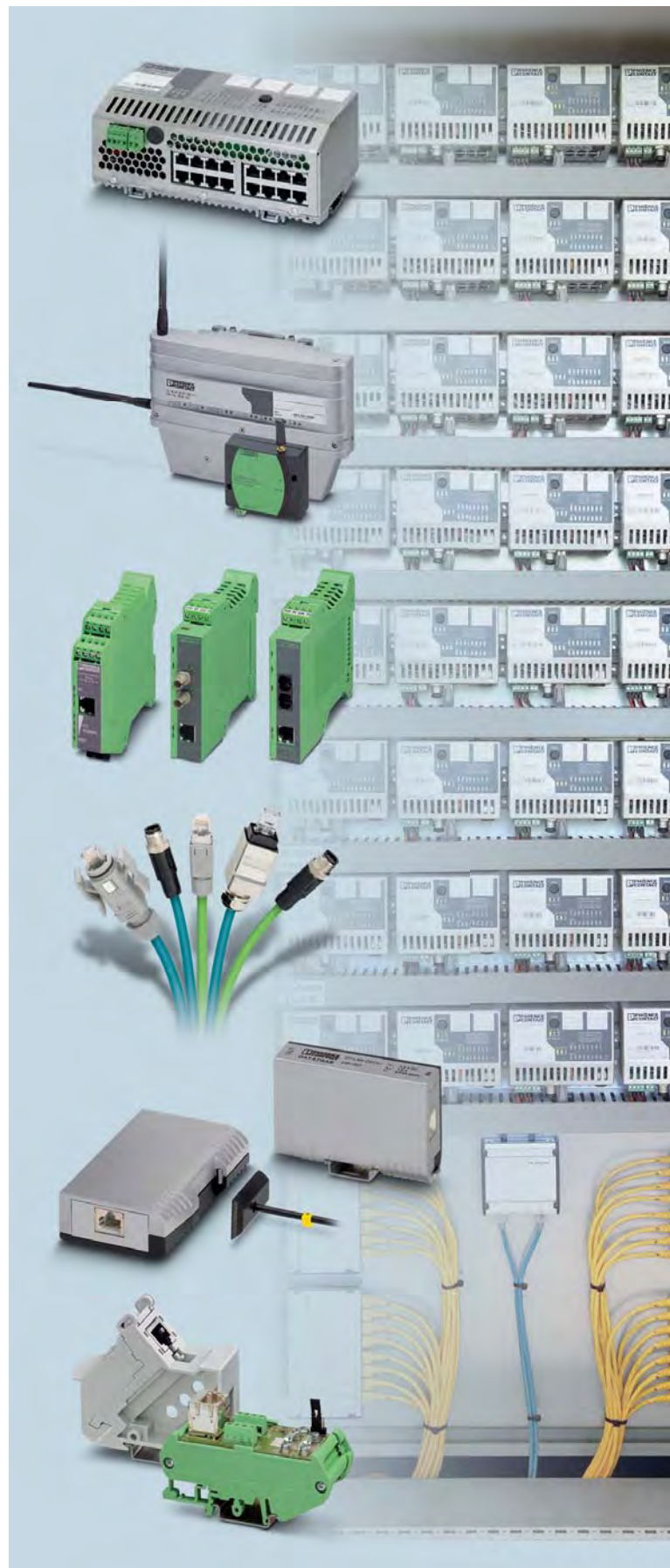

Switch Order Overview

Standard Switches

SFNB (temperature range: -10°C - 60°C)

Order No.	Type	Cu	FO	Nominal Voltage
2891001	FL SWITCH SFNB 5TX	5	-	12 - 48 V DC
2891002	FL SWITCH SFNB 8TX	8	-	9 - 32 V DC
2891027	FL SWITCH SFNB 4TX/FX	4	1-SC MM	12 - 48 V DC
2891028	FL SWITCH SFNB 4TX/FX ST	4	1-ST MM	12 - 48 V DC
2891029	FL SWITCH SFNB4TX/FX SM20	4	1-SC SM	12 - 48 V DC

SF (temperature range: 0°C - 55°C)

2832577	FL SWITCH SF 7TX/FX ST	7	1-ST MM	18.5 - 30.2 V DC
2832933	FL SWITCH SF 6TX/2FX	6	2-SC MM	18.5 - 30.2 V DC
2832674	FL SWITCH SF6TX/2FX ST	6	2-ST MM	18.5 - 30.2 V DC
2832603	FL SWITCH SF 4TX/3FX ST	4	4-ST MM	18.5 - 30.2 V DC
2832849	FL SWITCH SF 16TX	16	-	18.5 - 30.2 V DC
2832661	FL SWITCH SF 15TX/FX	15	1-SC MM	18.5 - 30.2 V DC
2832593	FL SWITCH SF 14TX/2FX	14	2-SC MM	18.5 - 30.2 V DC
2832771	FL SWITCH SF 8TX	8	-	18.5 - 30.2 V DC
2832726	FL SWITCH SF 7TX/FX	7	1-SC MM	18.5 - 30.2 V DC

SFN (temperature range: 0°C - 60°C)

2891152	FL SWITCH SFN 5TX	5	-	18.5 - 30.2 V DC
2891453	FL SWITCH SFN 4TX/FX ST	4	1-ST MM	18.5 - 30.2 V DC
2891851	FL SWITCH SFN 4TX/FX	4	1-SC MM	18.5 - 30.2 V DC
2891929	FL SWITCH SFN 8TX	8	-	18.5 - 30.2 V DC
2891097	FL SWITCH SFN 7TX/FX	7	1-SC MM	18.5 - 30.2 V DC
2891110	FL SWITCH SFN 7TX/FX ST	7	1-ST MM	18.5 - 30.2 V DC
2891314	FL SWITCH SFN 6TX/2FX	6	2-SC MM	18.5 - 30.2 V DC
2891411	FL SWITCH SFN 6TX/2FX ST	6	2-ST MM	18.5 - 30.2 V DC
2891021	FL SWITCH SFN 5TX-24VAC	5	-	20 - 28 V DC
2891020	FL SWITCH SFN 8TX-24VAC	8	-	20 - 28 V DC
2891023	FL SWITCH SFN 7TX/FX-NF	7	1-SC MM	18.5 - 30.2 V DC
2891024	FL SWITCH SFN 6TX/2FX-NF	6	2-SC MM	18.5 - 30.2 V DC
2891933	FL SWITCH SFN 16TX	16	-	12 - 48 V DC
2891934	FL SWITCH SFN 15TX/FX	15	1-SC MM	12 - 48 V DC
2891935	FL SWITCH SFN 14TX/2FX	14	2-SC MM	12 - 48 V DC

SFNT (temperature range: -40°C - 75°C)

2891003	FL SWITCH SFNT 5TX	5	-	9 - 32 V DC
2891004	FL SWITCH SFNT 4TX/FX	4	1-SC MM	9 - 32 V DC
2891005	FL SWITCH SFNT 8TX	8	-	9 - 32 V DC
2891006	FL SWITCH SFNT 7TX/FX	7	1-SC MM	9 - 32 V DC
2891007	FL SWITCH SFNT 7TX/FX ST	7	1-ST MM	9 - 32 V DC
2891952	FL SWITCH SFNT 16TX	16	-	12 - 48 V DC
2891953	FL SWITCH SFNT 15TX/FX	15	1-SC MM	12 - 48 V DC
2891954	FL SWITCH SFNT 14TX/2FX	15	1-ST MM	12 - 48 V DC
2891025	FL SWITCH SFNT 6TX/2FX	6	2-SC MM	9 - 32 V DC
2891026	FL SWITCH SFNT 6TX/2FX ST	6	2-ST MM	9 - 32 V DC

Standard Switches

SFN (temperature range: -25°C - 60°C/* 0°C - 60°C/** -25°C - 75°C)

Order No.	Type	Cu	FO	Nominal Voltage
2891398	FL SWITCH SFN 6GT/2SX	6	2-SC MM	9 - 30.2 V DC
2891987	FL SWITCH SFN 6GT/2LX	6	2-SC SM	9 - 30.2 V DC
2891563	FL SWITCH SFN 6GT/2LX-20*	6	2-SC SM	9 - 30.2 V DC
2891676	FL SWITCH SFN 8GT**	8	-	9 - 30.2 V DC
2891518	FL SWITCH SFN 7GT/SX**	7	1-SC MM	18.5 - 30.2 V DC

Managed Switches

SMCS (temperature range: 0°C - 55°C)

Order No.	Type	Cu	FO	Nominal Voltage
2891123	FL SWITCH SMCS 8GT	8	-	18 - 32 V DC
2891479	FL SWITCH SMCS 6GT/2SFP	6	2-SFP	18 - 32 V DC

Modular Managed Switches

GHS (temperature range: -20°C - 55°C)

Order No.	Type	Cu	FO	Nominal Voltage
2989200	FL SWITCH GHS 12G/8	Max. 24	4-SFP	18.5 - 30.2 V DC
2700271	FL SWITCH GHS 4G/12*	Max. 24	4-SFP	18.5 - 30.2 V DC

* Gigabit interface either as copper or SFP port.

Lean Managed Switches

LM (temperature range: -40°C - 70°C)

Order No.	Type	Cu	FO	Nominal Voltage
2989527	FL SWITCH LM 5TX	5	-	18.5 - 30.5 V DC
2832632	FL SWITCH LM 8TX	8	-	18.5 - 30.5 V DC
2891466	FL SWITCH LM 8TX-E	8	-	18.5 - 30.5 V DC
2989624	FL SWITCH LM 4TX/1FX	4	1-SC MM	18.5 - 30.5 V DC
2989721	FL SWITCH LM 4TX/1FX ST	4	1-ST MM	18.5 - 30.5 V DC
2832658	FL SWITCH LM 4TX/2FX	4	2-SC MM	18.5 - 30.5 V DC
2989132	FL SWITCH LM 4TX/2FX ST	4	2-ST MM	18.5 - 30.5 V DC
2891660	FL SWITCH LM 4TX/2FX-E	4	2-SC MM	18.5 - 30.5 V DC
2989828	FL SWITCH LM 4TX/1FX SM	4	1-SC SM	18.5 - 30.5 V DC
2989925	FL SWITCH LM 4TX/1FX SM ST	4	1-ST SM	18.5 - 30.5 V DC
2891916	FL SWITCH LM 4TX/2FX SM	4	2-SC SM	18.5 - 30.5 V DC
2989239	FL SWITCH LM 4TX/2FX SM ST	4	2-ST SM	18.5 - 30.5 V DC
2891864	FL SWITCH LM 4TX/2FX SM-E	4	2-SC SM	18.5 - 30.5 V DC

Managed Switches

SMCS and MCS (temperature range: 0°C - 55°C/* 0°C - 60°C)

Order No.	Type	Cu	FO	Nominal Voltage
2700290	FL SWITCH SMN 6TX/2POF-PN	6	2-POF SCRJ	18 - 32 V DC
2989226	FL SWITCH SMCS 8TX*	8	-	18 - 32 V DC
2989323	FL SWITCH SMCS 6TX/2SFP	6	2-SFP	18 - 32 V DC
2832700	FL SWITCH MCS 16TX	14	-	18.5 - 30.5 V DC
2832713	FL SWITCH MCS 14TX/2FX	16	2-SC MM	18.5 - 30.5 V DC

NAT Switches

SMN (temperature range: 0°C - 55°C)

Order No.	Type	Cu	FO	Nominal Voltage
2989365	FL NAT SMN 8TX	8	-	18 - 32 V DC

IP67 Switch

IP67 (temperature range: -40°C - 75°C)

Order No.	Type	Cu	FO	Nominal Voltage
2700200	FL SWITCH 1605 M12	5	-	18 - 32 V DC

10/100 Mbps

1000 Mbps

Varioface System Cabling

Conventional signal wiring from the process control system to the field signals is considerably time-consuming. Moreover, wiring faults cannot be ruled out.

Connections to the input and output cards of the process control system can also be simplified and accelerated using pre-assembled system cables and interface modules/termination boards which are adapted to these system cables. System cabling is a wiring concept developed especially for establishing connections to process control systems and is being constantly upgraded.

From purely passive direct links, power networking and signal conditioning, choose the right termination board to suit the field signals.

Quick, fault-free and uniform I/O wiring is possible with the help of pluggable components.



System cabling
Yokogawa control system CS3000 R3



Interface modules with system cables
to the control system

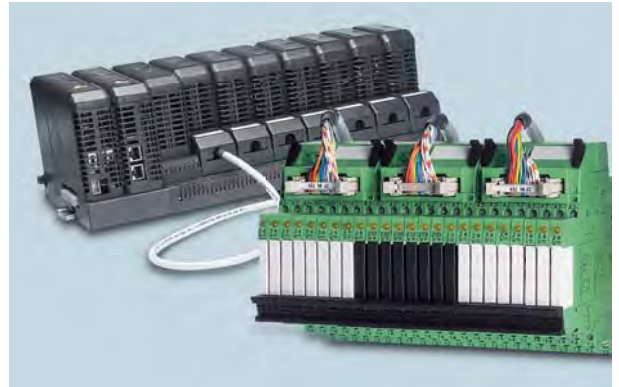

VARIOFACE System cabling Emerson DeltaV

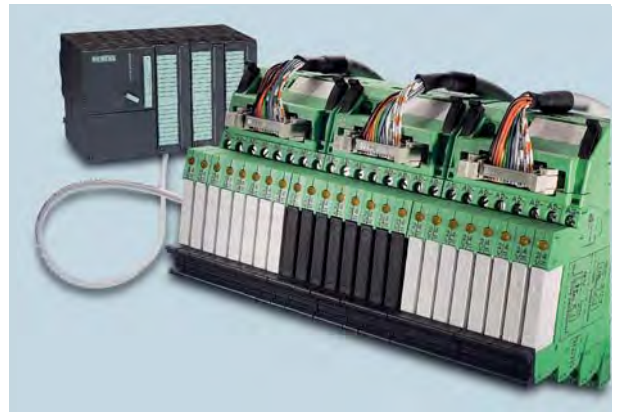

VARIOFACE System cabling Siemens

VARIOFACE system cabling is available for the following process control systems: ABB, Emerson, Honeywell, Siemens, Yokogawa.

Features include:

- Easy planning
- Cost reduction during wiring
- Fault minimisation without the risk of polarity reversal
- Easy maintenance through modular system components

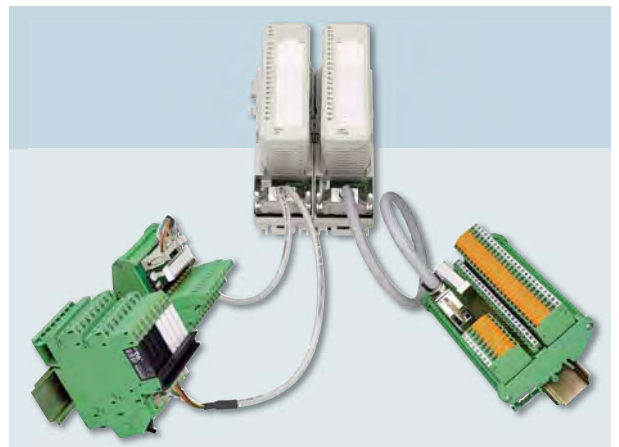

VARIOFACE System cabling ABB

Varioface: Perfect Fit System Cabling for I/O Modules:

Siemens S7300	Siemens S7400	Yokogawa CS 3000 R3	Yokogawa Stardom	Emerson DeltaV	ABB S800	Honeywell PlantScape
6ES7 321-1BH02-0AA0	6ES7421-1BL01-0AA0	ADV 151 Digital Input, 32 channels	NFDV 151 Digital Input, 32 channels	VE4001S2T1B3 Discrete Input Card 8 Channels 24 V DC, Isolated	DI810	TC-IDK 161
6ES7 321-1BH10-0AA0	6ES7 421-7BH01-0AB0	ADV 161 Digital Input, 64 channels	NFDV 151 Digital Output, 32 channels	VE4001S2T2B3 Discrete Input Card 8 Channels 24 V DC, Dry Contact	DI811	TC-IDX 161
6ES7 321-1BH50-0AA0	6ES7 421-7DH00-0AB0	ADV 551 Digital Output, 32 channels	NFAI 141 NFAI 413 Analog Input, 32 channels	Series2 Discrete Input Card 8 Channels 24 V DC, Dry Contact	DI814	TC-IDJ 161
6ES7321-1BL00-0AA0	6ES7422-1BL00-0AA0	ADV 561 Digital Output, 64 channels	NFAI 543 Analog Output	VE4001S5T2B5 Sequence of Events I/O Card 16 Channels 24 V DC	DI830	TC-IDD 321
6ES7 321-7BH01-0AB0	6ES7 422-7BL00-0AB0	AAI 135 AAI 141 AAI 143 AAI 181 AAI 141 AAV 141 AAV 142 AAI 135 Analog Input		VE4001S2T2B5 Discrete Input Card 32 Channels 24 V DC, Dry Contact	DI831	TC-ODD 321
6ES7 322-1BH01-0AA0	6ES7 431-0HH00-0AB0			VE4002S1T1B3 Discrete Output Card 8 Channels 24 V DC, Isolated	DI840	TC-IAH 161
6ES7322-1BL00-0AA0	6ES7 431-1KF00-0AB0			VE4002S1T2B3 Discrete Output Card 8 Channels 24 V DC, High Side	DI885	TC-IDX 081
6ES7 322-8BF00-0AB0	6ES7 431-1KF10-0AB0			Series2 Discrete Output Card 8 Channels 24 V DC, High Side	DO810	TC-IDA 161
6ES7 323-1BH01-0AA0	6ES7 431-1KF20-0AB0	AAB 841 AAI 543 AAI 835 AAV 542 Analog Output		VE4002S1T2B4 Discrete Output Card 8 Channels 24 V DC, High Side	DO814	TC-IAH 061
6ES7323-1BL00-0AA0	6ES7 431-7KF00-0AB0			VE4002S1T2B6 Discrete Output Card 32 Channels 24 V DC, High Side	DO840	TC-IXR 061
6ES7 331-1KF01-0AB0	6ES7 431-7KF10-0AB0			VE4003S2B4 Analog Input Card 8 Channels 4-20 mA, HART	DP820	TC-IXL 061
6ES7 331-7HF01-0AB0	6ES7 431-7QH00-0AB0			VE4003S3B4 Analog Input Card 8 Channels 1-5 V DC	AI810	TC-OAH 061
6ES7 331-7KB02-0AB0	6ES7 432-1HF00-0AB0			VE4003S3B5 Analog Input Card 8 Channels 1-5 V DC	AI820	TC-OAV 061
6ES7 331-7KF02-0AB0				VE4005S2B3 Analog Output Card 8 Channels 4-20 mA, HART	AI830	TC-OAV 081
6ES7 331-7PF01-0AB0					AI835	
6ES7 331-7PF11-0AB0					AI845	
6ES7 331-7NF00-0AB0					AO810	
6ES7 331-7NF10-0AB0					AO820	
6ES7 332-5HD01-0AB0					AO845	
6ES7 332-5HB01-0AB0						
6ES7 332-7ND02-0AB0						
6ES7 334-0CE01-0AA0						
6ES7 334-0KE00-0AB0						
6ES7 335-7HG01-0AB0						
6ES7 338-4BC01-0AB0						
6ES7 350-1AH03-0AE0						
6ES7 350-2AH00-0AE0						
6ES7 351-1AH01-0AE0						
6ES7 352-1AH01-0AE0						
6ES7 353-1AH01-0AE0						
6ES7 354-1AH01-0AE0						
6ES7 355-0VH10-0AE0						
6ES7 355-1VH10-0AE0						
6ES7 357-4AH01-0AE0						
CPU 312 C						
CPU 313 C						
CPU 314 C						

Components for Signal Conditioning

Coupling Relay – PLC INTERFACE

Equipped with relay or solid-state relay, PLC INTERFACE is used for electrical isolation, level adjustment and power networking between field devices and the control system. The 6 mm narrow modules can be easily bridged and are available with a screw or spring-cage connection. The V8 adapter simultaneously connects eight modules to the control system.

Solid-State Contactor – CONTACTRON “4 in 1”

This solid-state reversing contactor provides four functions over just 22.5 mm: Right contactor, left contactor, motor protection relay and emergency stop up to category 3, SIL3. CONTACTRON has an extremely long service life and can safely switch drives up to approx. 4 kW. The module has an EU type-examination certificate as per ATEX.

Safety Relays – SIL

The SIL3-certified PSR safety relays provide solutions for all common applications, from emergency stop monitoring to establishing connections with failsafe control systems. In addition to applications as per IEC 61508 and IEC 61511, offshore systems as per Germanic Lloyd (GL) guidelines can also be realised.

Signal Isolation with MINI MCR

Measuring temperatures, converting or isolating signals - no problem with MINI Analog. The 6.2 mm slim modules with three-way isolation execute tasks with absolute precision and minimal current consumption. The result is perfect transmission quality and a long service life. The V8 adapter simultaneously connects eight modules to the control system.

Surge Protection – TRABTECH

Strong protection against malfunctions is essential to maintaining safety and high system availability. TRABTECH lightning and surge protection modules for the power supply unit, the field and bus signals protect the sensitive process control system.

Power Supply Units – QUINT POWER

The especially slim and narrow QUINT POWER power supply units feature many functional advantages. These devices are equipped with Power Boost, preventive function monitoring and selective fuse breaking technology (SFB technology).

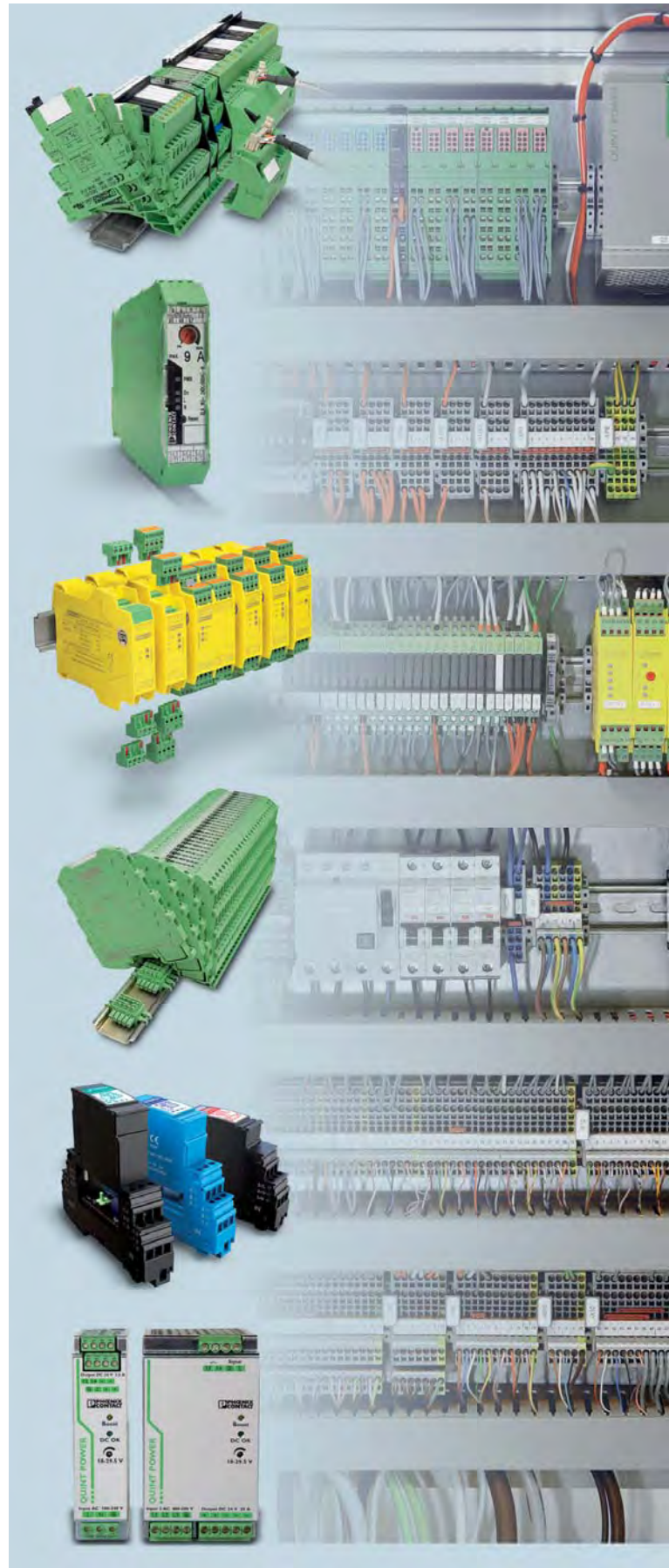

PLC Interface Relay Selection Guide

Series	Function	Contact	Input	Output	Spring-cage Connection	Order No.	Screw Connection	Order No.	PLC-V8...OUT1(M)	PLC-V8...IN(M)	PLC-V8...OUT		
Universal	Relay	SPDT	24 V DC	250 V AC/DC / 6 A	PLC-RSP-24DC/21	2966472	PLC-RSC-24DC/21	2966171	X				
			24 V DC	250 V AC/DC / 10 A	PLC-RSP-24DC/21HC	2912277	PLC-RSC-24DC/21HC	2967620			X		
			12 V DC	30 V AC/DC / 50 mA	PLC-RSP-12DC/21AU	2967442	PLC-RSC-12DC/21HU	2966919		X			
			24 V DC	30 V AC/DC / 50 mA	PLC-RSP-24DC/21AU	2966540	PLC-RSC-24DC/21AU	2966265	X	X			
			24 V AC/DC	30 V AC/DC / 50 mA	PLC-RSP-24UC/21AU	2966553	PLC-RSC-24UC/21AU	2966278	X	X			
			48 V DC	30 V AC/DC / 50 mA	PLC-RSP-48DC/21AU	2966566	PLC-RSC-48DC/21AU	2966126		X			
			60 V DC	30 V AC/DC / 50 mA	PLC-RSP-60DC/21AU	2966579	PLC-RSC-60DC/21AU	2966142		X			
			120 V AC/DC	30 V AC/DC / 50 mA	PLC-RSP-120UC/21AU	2966582	PLC-RSC-120UC/21AU	2966281		X			
			230 V AC/DC	30 V AC/DC / 50 mA	PLC-RSP-230UC/21AU	2966647	PLC-RSC-230UC/21AU	2966294		X			
			24 V DC	250 V AC/DC / 6 A	PLC-RSP-24DC/21-21	2912507	PLC-RSC-24DC/21-21	2967060			X		
			24 V DC	30 V AC/DC / 50 mA	PLC-RSP-24DC/21-21AU	2912578	PLC-RSC-24DC/21-21AU	2967125			X		
			24 V DC	24 V DC/3 A	PLC-OSP-24DC/24DC/2	2967471	PLC-OSC-24DC/24DC/2	2966634	X				
			24 VDC	24 V DC/10 A	PLC-OSP-24DC/24DC/10/R	2982715	PLC-OSC-24DC/24DC/10/R	2982702	X				
			24 V DC	250 V AC/0.75 A	PLC-OSP-24DC/230AC/1	2967895	PLC-OSC-24DC/230AC/1	2967840	X				
	24 V DC	300 V DC/1 A	PLC-OSP-24DC/300DC/1	2980830	PLC-OSC-24DC/300DC/1	2960678	X						
	Solid-state relays	1 N/O contact, electronic	24 V DC	48 V DC/ 100 mA	PLC-OSP-24DC/48DC/100	2967549	PLC-OSC-24DC/48DC/100	2966728	X	X			
			48 V DC	48 V DC/ 100 mA	PLC-OSP-48DC/48DC/100	2967743	PLC-OSC-48DC/48DC/100	2966993		X			
			60 V DC	48 V DC/ 100 mA	PLC-OSP-60DC/48DC/100	2967756	PLC-OSC-60DC/48DC/100	2967455		X			
			120 V AC/DC	48 V DC/ 100 mA	PLC-OSP-120UC/48DC/100	2967552	PLC-OSC-120UC/48DC/100	2966744		X			
			230 V AC/DC	48 V DC/ 100 mA	PLC-OSP-230UC/48DC/100	2967565	PLC-OSC-230UC/48DC/100	2966757		X			
			1 N/O contact, electronic	NAMUR	24 V DC/ 50 mA	PLC-SP-EIK 1-SVN 24P/P	2982676	PLC-SC-EIK 1-SVN 24P/P	2982663		X		
			1 PDT, electronic	24 V DC	48 V DC/0.5 A	PLC-OSP-24DC/48DC/500/W	2980649	PLC-OSC-24DC/48DC/500/W	2980636	X			
			Feed-through	-	250 V AC/DC	250 V AC/DC	-	-	PLC-VT	2296870	X	X	
					24 V DC	24 V DC	-	-	PLC-VT/LA	2996854	X	X	
			Actuator	Relay	1 N/O contact	24 V DC	250 V AC/DC / 6 A	PLC-RSP-24DC/1/ACT	2967345	PLC-RSC-24DC/1/ACT	2966210	X	
						24 V DC	250 V AC/DC / 10 A (80 A; 20 ms)	PLC-RSP-24DC/11C/ACT	2912413	PLC-RSC-24DC/11C/ACT	2967604		X
				Solid-state relays	1 N/O contact electronic	24 V DC	250 V AC/DC / 6 A	-	-	PLC-RSC-24DC/1-1/ACT	2967109		X
						24 V DC	24 V DC/3 A	PLC-OSP-24DC/24DC/2/ACT	2967507	PLC-OSC-24DC/24DC/2/ACT	2966676	X	
Feed-through				-	24 V DC	250 V AC/0.75 A	-	-	PLC-OSC-24DC/230AC/1/ACT	2967947	X		
	250 V AC/DC	250 V AC/DC			-	-	PLC-VT/ACT	2205567	X				
Sensor	Relay	1 N/O contact	24 V DC	30 V AC/DC / 50 mA	PLC-RSP-24DC/1AU/SEN	2967374	PLC-RSC-24DC/1AU/SEN	2966317		X			
			120 V AC/DC	30 V AC/DC / 50 mA	PLC-RSP-120UC/1AU/SEN	2967390	PLC-RSC-120UC/1AU/SEN	2966320		X			
			230 V AC/DC	30 V AC/DC / 50 mA	PLC-RSP-230UC/1AU/SEN	2967413	PLC-RSC-230UC/1AU/SEN	2966333		X			
			24 V DC	48 V DC/ 100 mA	PLC-OSP-24DC/48DC/100/SEN	2967578	PLC-OSC-24DC/48DC/100/SEN	2966773	X				
	Solid-state relays	1 N/O contact electronic	120 V AC/DC	48 V DC/ 100 mA	PLC-OSP-120UC/48DC/100/SEN	2967581	PLC-OSC-120UC/48DC/100/SEN	2966799		X			
			230 V AC/DC	48 V DC/ 100 mA	PLC-OSP-230UC/48DC/100/SEN	2967594	PLC-OSC-230UC/48DC/100/SEN	2966809		X			

PSR Safety Relays

Type input voltage	Applications					Output Contacts			Safety Approvals				Connection	Order No.
									CAT/EN 954-1	PL/ISO 13849-1	SIL/IEC 62061	SIL/IEC 61508		
PSR-ESM4 24 V AC/DC	X	X	-	-	-	2	-	1	4	e	3	-	SCP	2963718
PSR-ESM4-B 24 V AC/DC	X	X	-	-	-	3	-	1	4	e	3	-	SPP	2963705
													SCP	2963776
PSR-ESA4 24 V AC/DC	X	X	-	-	-	2	-	1	4	e	3	-	SCP	2963750
													SPP	2963938
PSR-ESA4-B 24 V AC/DC	X	X	-	-	-	3	-	1	4	e	3	-	SCP	2963763
													SPP	2963941
PSR-ESA2-B 24 V AC/DC	X	X	-	-	-	4	-	1	2 ¹⁾	d ¹⁾	3	-	SCP	2963802
													SPP	2963954
PSR-ESAM4/3X1 24 V... 230 V AC/DC	X	X	-	-	-	3	-	1	4	e	3	3	SCP	2981114
													SPP	2981127
PSR-ESP4 24 V DC	X	X	-	-	-	2	-	1	2 ¹⁾	d ¹⁾	3	3	SCP	2981020
													SPP	2981017
PSR-ESAM4 24 V AC/DC	X	X	X ⁹⁾	-	-	8	-	1	4	e	3	-	SCP	2963912
													SPP	2963996
PSR-ESL4 24 V AC/DC	X	X	X	-	-	3	-	1	4	e	3	-	SCP	2981059
													SPP	2981062
PSR-ESD-30 24 V DC	X	X	X	-	-	2	2	-	4	e	3	-	SCP	2981800
													SPP	2981813
PSR-ESD-300 24 V DC	X	X	X ⁹⁾	-	-	3	2	1	4 ⁴⁾	e ⁴⁾	3 ⁴⁾	-	SCP	2981428
													SPP	2981431
PSR-ESD-T 24 V DC	X	X	X ⁹⁾	-	-	3	2	1	4 ⁴⁾	e ⁴⁾	3 ⁴⁾	-	SCP	various fixed functions of time - see catalog for ordering data
													SPP	
PSR-THC4 24 V AC/DC	-	X	-	-	X	2	-	1	4 ³⁾	e	3	-	SCP	2963721
													SPP	2963983
PSR-SDC4 24 V DC	X	X	X	X	-	2	-	1 ³⁾ N.O.	4	e	3	-	SCP	2981486
													SPP	2981499
PSR-FSP 24 V DC	Emergency stop coupling relay for failsafe controllers in the process industry					1	-	1	-	-	-	3	SCP	2981978
	SPP	2981981												
PSR-URM4 24 V AC/DC	Contact extensions					5	-	2	4	e	3	3	SCP	2963734
	SPP	2964005												
PSR-URM4-B 24 V AC/DC	Contact extensions					5	-	2	4	e	3	3	SCP	2981033
	SPP	2981046												





SCP = pluggable screw terminal block, SPP = pluggable spring-cage terminal block, ¹⁾ = Cat. 4/PL e with additional measures, ²⁾ + Type IIIC as per EN 574, ³⁾ = semiconductor output, ⁴⁾ = undelayed contacts: Cat. 4, PL e SILCL 3, drop-out delay contacts: Cat. 3 PL d, SILCL 2, ⁵⁾ = light grid types on request.

Power Supply Units - Quint Power



QUINT POWER 1 SFB TECHNOLOGY





Input: 1-phase, 85 - 264 V AC, 90 - 350 V DC

				
24 V / 3.5 A¹ QUINT-PS/1AC/24DC/3.5 2866747	24 V / 5 A¹ QUINT-PS/1AC/24DC/5 2866750	24 V / 10 A¹ QUINT-PS/1AC/24DC/10 2866763	24 V / 20 A QUINT-PS/1AC/24DC/20 2866776	24 V / 40 A QUINT-PS/1AC/24DC/40 2866789
		48 V / 5 A QUINT-PS/1AC/48DC/5 2866679	48 V / 10 A QUINT-PS/1AC/48DC/10 2866682	48 V / 20 A QUINT-PS/1AC/48DC/20 2866695
		12 V / 15 A QUINT-PS/1AC/12DC/15 2866718	12 V / 20 A QUINT-PS/1AC/12DC/20 2866721	

¹ also certified according to 







QUINT POWER 3 SFB TECHNOLOGY

Input: 3-phase, 3 x 320-575 V AC, 450-800 V DC

			
24 V / 5 A QUINT-PS/3AC/24DC/5 2866734	24 V / 10 A QUINT-PS/3AC/24DC/10 2866705	24 V / 20 A QUINT-PS/3AC/24DC/20 2866792	24 V / 40 A QUINT-PS/3AC/24DC/40 2866802
			48 V / 20 A QUINT-PS/3AC/48DC/20 2320827

QUINT POWER, dip coated SFB TECHNOLOGY

Input: 1-phase: 85 - 264 V AC, 90 - 350 V DC / 3-phase: 3x 320 - 575 V AC, 450 - 800 V DC

 	 		
1 AC / 24 V / 5 A QUINT-PS/1AC/24DC/5/CO 2320908	1 AC / 24 V / 10 A QUINT-PS/1AC/24DC/10/CO 2320911	1 AC / 24 V / 20 A QUINT-PS/1AC/24DC/20/CO 2320898	1 AC / 24 V / 20 A QUINT-PS/3AC/24DC/20/CO 2320924

Redundancy Modules Decouple, Monitor & Control

A redundant power supply system is the result of the parallel connection of two power supply units. This solution can be optimised: In order to increase system availability, the power supply units must be decoupled and the redundancy should be monitored. The following are ideal solutions:

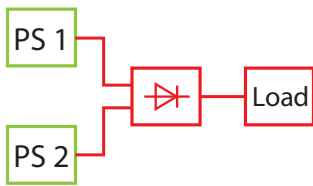

Quint Diode, Step Diode

Decoupling with diode for monitoring of the power supply voltage.

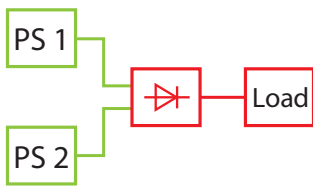

Trio Diode

Decoupling with redundancy module for monitoring of the power supply voltages and the wiring.

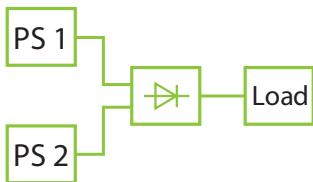

Quint Oring

Decoupling with active redundancy module for monitoring of the power supply voltages, wiring, the decoupling and the load current.



QUINT ORING

Input: 18 - 30 V DC

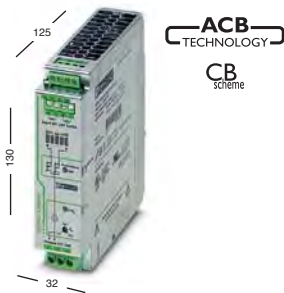

24 V / 2 x 10 A / 1 x 20 A

QUINT-ORING/24DC/2X10/1X20
2320173

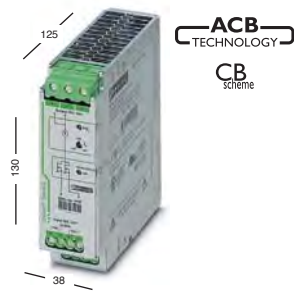

24 V / 2 x 20 A / 1 x 40 A

QUINT-ORING/24DC/2X20/1X40
2320186

QUINT DIODE

Input: 10 - 30 V DC, 30 - 56 V DC



12-24 V / 2 x 20 A / 1 x 40 A

QUINT-DIODE/12-24DC/2X20/1X40
2320157

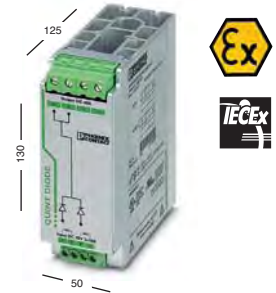

48 V / 2 x 20 A / 1 x 40 A

QUINT-DIODE/48DC/2X20/1X40
2320160

Isolating Amplifiers, Surge Protection and Connection Technology for Ex i Signals

MACX IS Isolated Barriers

The intrinsically safe one and two-channel isolated barriers of the MACX EX series provide a comprehensive range of functions in a housing just 12.5 mm wide. MACX EX isolated barriers are approved as per ATEX, IECEx, SIL and UL and can be used for circuits in up to Ex Zone 0 and 20. With their Ex n approval, the isolated barriers can be installed in Zone 2.

Surge Protection Suitable for the Control Cabinet

The ideal surge protection for the intrinsically safe circuits are the two-section PLUGTRABs. The plug with the protective electronics is inserted into the permanently wired base element. The plugs are available for 2x2 signal circuits or for three/four-wire measuring technology.

Jumpering of Field Signals

The field signals can be jumpered on the isolating amplifiers with modular terminal blocks with screw, spring-cage or fast connection technology. CLIPLINE complete provides a wide range of variants such as knife disconnection and hybrid terminal blocks for intrinsically safe circuits.

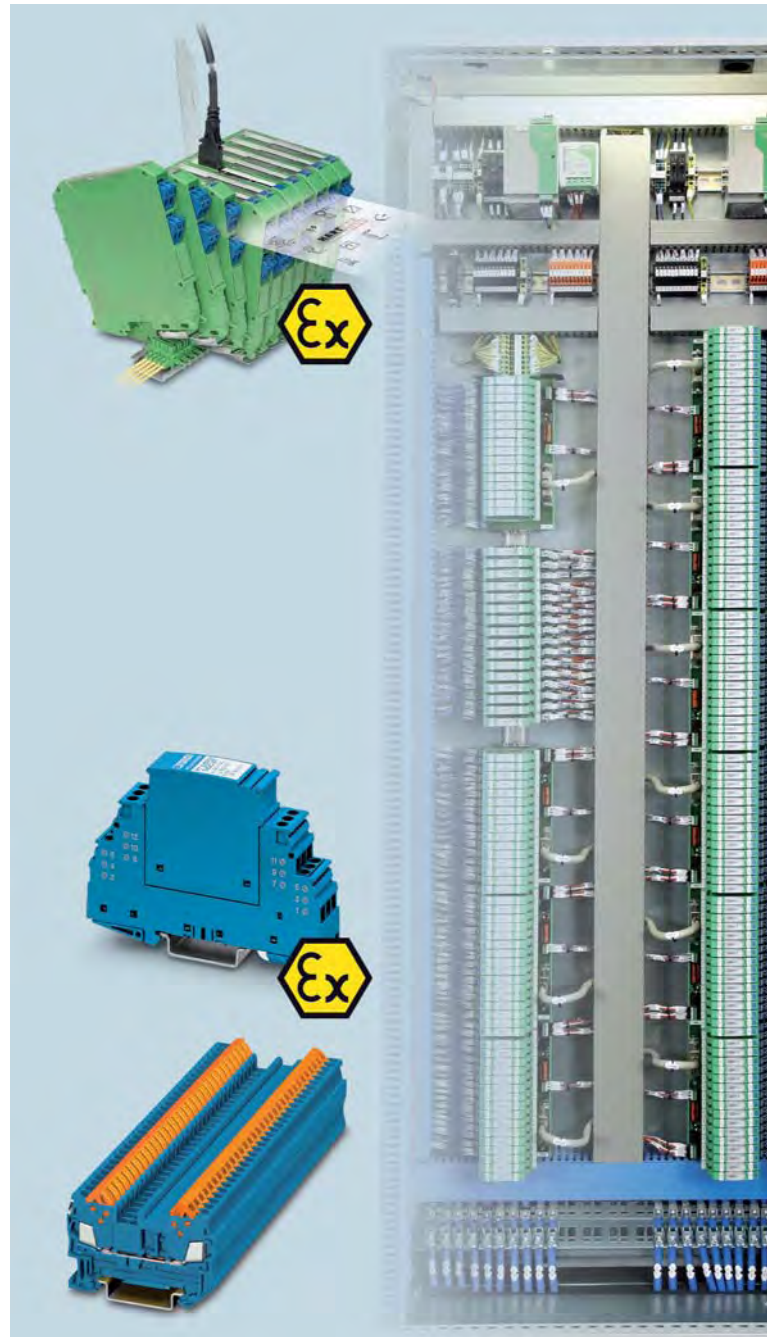

Surge Protection for Field Devices
The rugged SURGETRAB protects field devices in the Ex areas. Additional areas of application are PROFIBUS PA and Foundation Fieldbus installations.

Field Distributors
Field wiring in Zone 2 with modular terminal blocks from Phoenix Contact with screw connection technology.

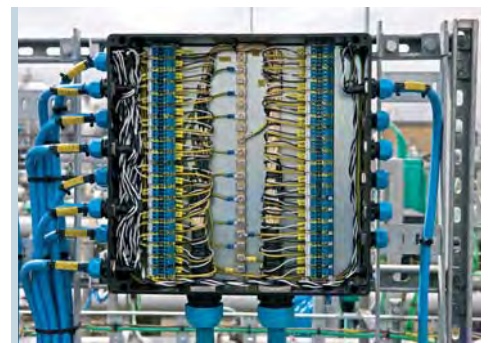

MACX Analog Ex - Technical data



		Analog IN		Analog OUT		Digital IN			
		Repeater power supply and input isolating amplifier Transmission of the HART protocol	Repeater power supply and input isolating amplifier Transmission of the HART protocol, with long range supply	Output isolator Transmission of the HART protocol, line break detection	NAMUR switching isolator • 1-channel Error message on T-connector	NAMUR switching isolator • 1-channel Error message on T-connector	NAMUR switching isolator • 2-channel Error message on T-connector	NAMUR switching isolator • 1-channel Error message on T-connector	NAMUR switching isolator • 2-channel Error message on T-connector
IN	intrinsically safe [Ex ia] II C 0/4...20 mA (active, passive) Transmitter supply voltage 16 V at 20 mA	intrinsically safe [Ex ia] II C 0/4...20 mA (active, passive), 0/1...5 V Transmitter supply voltage 16 V at 20 mA	0/4...20 mA	intrinsically safe [Ex ia] II C NAMUR proximity sensors, floating switch contacts, switching contacts with resistance circuits	intrinsically safe [Ex ia] II C NAMUR proximity sensors, floating switch contacts, switching contacts with resistance circuits	intrinsically safe [Ex ia] II C NAMUR proximity sensors, floating switch contacts, switching contacts with resistance circuits	intrinsically safe [Ex ia] II C NAMUR proximity sensors, floating switch contacts, switching contacts with resistance circuits	intrinsically safe [Ex ia] II C NAMUR proximity sensors, floating switch contacts, switching contacts with resistance circuits	
OUT	0/4...20 mA (active, passive) Load 0...600 Ω	0/4...20 mA (active, passive) 0/1...5 V Load 0...600 Ω	intrinsically safe [Ex ia] II C 0/4...20 mA Load 0...800 Ω	Relay PDT contact Max. switching voltage: 250 V AC (2 A) / 120 V DC (0.2 A) / 30 V DC (2 A)	2 x relay N/O contact Max. switching voltage: 250 V AC (2 A) / 120 V DC (0.2 A) / 30 V DC (2 A)	Relay N/O contact Max. switching voltage: 250 V AC (2 A) / 120 V DC (0.2 A) / 30 V DC (2 A)	2 x transistor, passive Max. switching voltage: 30 V DC (60 mA) per output Max. switching frequency: 5 kHz	Transistor, passive Max. switching voltage: 30 V DC (60 mA) Max. switching frequency: 5 kHz	
Design Width	12.5 mm	17.5 mm	12.5 mm	12.5 mm	12.5 mm	12.5 mm	12.5 mm	12.5 mm	
Screw Connection	MACX MCR-EX-SL-RPSSI-I Order No.: 2865340	MACX MCR-EX-SL-RPSSI-I-UP Order No.: 2865793	MACX MCR-EX-SL-IDSI-I Order No.: 2865405	MACX MCR-EX-SL-NAM-R Order No.: 2865434	MACX MCR-EX-SL-NAM-2R0 Order No.: 2865450	MACX MCR-EX-SL-2NAM-RO Order No.: 2865476	MACX MCR-EX-SL-2NAM-2T Order No.: 2865463	MACX MCR-EX-SL-2NAM-T Order No.: 2865489	
Spring-Cage Connection	MACX MCR-EX-SL-RPSSI-I-SP Order No.: 2924016	MACX MCR-EX-SL-RPSSI-I-UP-SP Order No.: 2924029	MACX MCR-EX-SL-IDSI-I-SP Order No.: 2924032	MACX MCR-EX-SL-NAM-R-SP Order No.: 2924045	MACX MCR-EX-SL-NAM-2R0-SP Order No.: 2924061	MACX MCR-EX-SL-2NAM-RO-SP Order No.: 2924087	MACX MCR-EX-SL-2NAM-2T-SP Order No.: 2924074	MACX MCR-EX-SL-2NAM-T-SP Order No.: 2924090	
		EX II (1) GD [Ex ia] IIC / IIB / IIA EX II 3 G Ex nA II T4 X SIL 2 acc. to IEC 61508	EX II (1) GD [Ex ia] IIC / IIB / IIA EX II 3 G Ex nA II T4 X SIL 2 acc. to IEC 61508	EX II (1) GD [Ex ia] IIC / IIB / IIA EX II 3 G Ex nA II T4 X SIL 2 acc. to IEC 61508	EX II (1) GD [Ex ia] IIC / IIB / IIA EX II 3 G Ex nAC II T4 X SIL 2 acc. to IEC 61508	EX II (1) GD [Ex ia] IIC / IIB / IIA EX II 3 G Ex nAC II T4 X SIL 2 acc. to IEC 61508	EX II (1) GD [Ex ia] IIC / IIB / IIA EX II 3 G Ex nAC II T4 X SIL 2 acc. to IEC 61508	EX II (1) GD [Ex ia] IIC / IIB / IIA EX II 3 G Ex nA II T4 X SIL 2 acc. to IEC 61508	
Digital OUT				Temperature		Accessories			
		Solenoid driver Loop-powered	Solenoid driver Loop-powered	Solenoid driver Loop-powered	Solenoid driver Loop-powered	Temperature measuring transducers	Temperature measuring transducers	Power and error message module	DIN rail connector (T-Bus) to bridge the supply voltage ME 6,2 TBUS-2 1,5/5-ST-3.81 GN Order No.: 2869728 Programming adapter With USB interface for programming the temperature measuring transducer with the MACX MCR-CONF software MACX USB-PROG-ADAPTER Order No.: 2811271
IN	Input current 10...70 mA DC (45 mA for U _e = 24 V DC)	Input current 10...95 mA DC (65 mA for U _e = 24 V DC)	Input current 10...95 mA DC (75 mA for U _e = 24 V DC)	Input current 10...105 mA DC (95 mA for U _e = 24 V DC)	intrinsically safe [Ex ia] II C • 2, 3 or 4-conductor resistance thermometer • Resistance-type sensor 0...400 Ω	intrinsically safe [Ex ia] II C • Thermocouple types J, K, N • mV signals: -75...+75 mV	Input voltage 19.2...30 V DC		
OUT	intrinsically safe [Ex ia] II C (B) • Output voltage 5.5 V DC (for 25 mA) • Non-load voltage 21.4 V DC	intrinsically safe [Ex ia] II C (B) • Output voltage 10.0 V DC (for 40 mA) • Non-load voltage 21.4 V DC	intrinsically safe [Ex ia] II C (B) • Output voltage 10.5 V DC (for 48 mA) • Non-load voltage 24 V DC	intrinsically safe [Ex ia] II C (B) • Output voltage 12.9 V DC (for 58 mA) • Non-load voltage 21.4 V DC	0/4...20 mA	0/4...20 mA	• Output voltage = (Input voltage - max. 0.8 V) • Error message - PDT relay		
Design Width	12.5 mm	12.5 mm	12.5 mm	12.5 mm	12.5 mm	12.5 mm	17.5 mm		
Screw Connection	MACX MCR-EX-SL-SD-21-25-LP Order No.: 2865492	MACX MCR-EX-SL-SD-21-40-LP Order No.: 2865764	MACX MCR-EX-SL-SD-24-48-LP Order No.: 2865609	MACX MCR-EX-SL-SD-21-60-LP Order No.: 2865515	MACX MCR-EX-SL-RTD-I Order No.: 2865939 (configured) MACX MCR-EX-SL-RTD-I-NC Order No.: 2865573 (non-configured)	MACX MCR-EX-SL-TC-I/... Order No.: 2865942 (configured) MACX MCR-EX-SL-TC-I-NC Order No.: 2865586 (non-configured)	MACX MCR-PTB Order No.: 2865625		
Spring-Cage Connection	MACX MCR-EX-SL-SD-21-25-LP-SP Order No.: 2924113	MACX MCR-EX-SL-SD-21-40-LP-SP Order No.: 2924139	MACX MCR-EX-SL-SD-24-48-LP-SP Order No.: 2924126	MACX MCR-EX-SL-SD-21-60-LP-SP Order No.: 2924100	MACX MCR-EX-SL-RTD-I-SP Order No.: 2924142 (configured) MACX MCR-EX-SL-RTD-I-SP-NC Order No.: 2924168 (non-configured)		MACX MCR-PTB-SP Order No.: 2924184		
		EX II (1) GD [Ex ia] IIC / IIB / IIA EX II 3 G Ex nA II T4 X SIL 3 acc. to IEC 61508	EX II (1) GD [Ex ia] IIC / IIB / IIA EX II 3 G Ex nA II T4 X SIL 3 acc. to IEC 61508	EX II (1) GD [Ex ia] IIC / IIB / IIA EX II 3 G Ex nA II T4 X SIL 3 acc. to IEC 61508	EX II (1) GD [Ex ia] IIC / IIB / IIA EX II 3 G Ex nA II T4 X SIL 3 acc. to IEC 61508	EX II (1) GD [Ex ia] IIC / IIB / IIA EX II 3 G Ex nAC II T4 X SIL 2 acc. to IEC 61508	EX II (1) GD [Ex ia] IIC / IIB / IIA EX II 3 G Ex nAC II T4 X SIL 2 acc. to IEC 61508	EX II 3 G Ex nA II T4 X	

Fiber Optic Technology for Profibus DP and Modbus

Conventional fieldbus installations with copper technology are restricted to the classic line structure which makes it difficult to set up redundant networks. Similarly, the attainable ranges are also limited depending on the data rate.

Any network structures and installation concepts optionally adapted to the existing system topology can also be realised using fiber optic technology. The fiber optic converters can be put together as a modular system using the PSI-MOS installation system. Devices with one or two fiber optic ports, with polymer, HCS/PCF and glass fiber technology are available and can form a modular optical hub by snapping them onto the DIN rail. The cross-wiring for the supply voltage and the data signals between devices takes place via a system bus (T-Bus) that is snapped onto the DIN rail. Our T-Bus system minimizes installation costs and prevents wiring errors. The system bus makes it possible to plug in and unplug PSI-MOS devices during operation.

The integrated optical diagnostics of the PSI-MOS devices constantly provides information about the signal quality of the optical path during the preliminary installation as well as during operation. With the help of a four-level bar graph, real time diagnostics can easily be seen. Complex calibration with special equipment is not required. If there is a drop in the optical signal quality, a warning is given via a switch contact. The module's ability to identify a drop in signal quality enables you to schedule preventive maintenance, and reduce costs in the event of a system failure.

Foundation Fieldbus and Profibus PA

The modular fieldbus segment protectors connect the process control system to the field devices safely and easily. The segment protectors can be expanded and replaced during operation depending on the requirement. Clear and economical fieldbuses for Foundation Fieldbus and Profibus PA can thus be implemented.

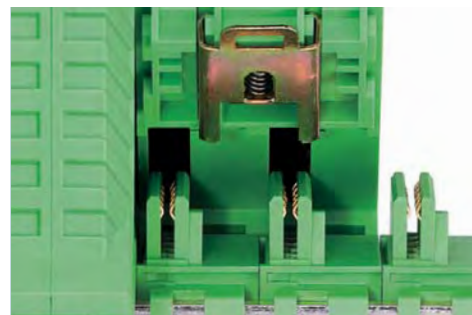
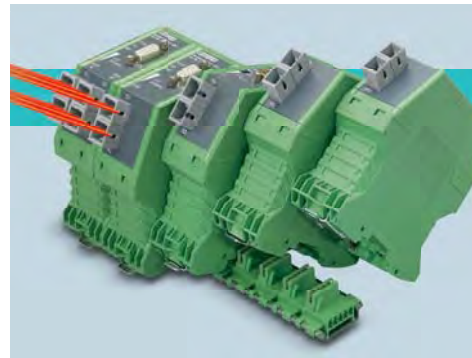

The cross-wiring for supply voltage and data signals is done via the modular system bus



The four-level bar graph visualised the signal quality of the fibre optic path





Redundant Power Supply

Order No.	Type	Description
2316132	FB-PS-PLUG...	Redundant power supply plg, 28 V at 0.5 A output
2316145	FB-PS-BASE...	Redundant power supply base



Simplex Power Supply

Order No.	Type	Description
2316035	FB-PS-25/0.3A	Power supply, conditioner for one fieldbus segment



Device Couplers

Order No.	Type	Description
2316044	FB-IS0	1-spur, isolated, for Zone 1 0/Div 1 connection
2316051	FB-2SP	2-spurs, for Zone 2/Div 2 connection
2316048	FB-ET	Trunk module with external terminator (included with field junction box)



Field Junction Box Assemblies

Order No.	Type	Description
2316187	FB-15-AL	Aluminium, 15 entry
2316190	FB-15-SS	Stainless, 15 entry
2316200	FB-8-AL	Aluminium, 8 entry
2316213	FB-9-SS	Stainless, 9 entry

Accessories

Order No.	Type	Description
2709561	ME 17.5 TBUS...	Bulk power bus for simplex PS (not included with the simplex PS)
2707437	ME 22.5 TBUS...	Spare for field device couplers (included with each device coupler)
2316226	D-FB-PS	Cover, redundant power supply, side base connections
1793260	ZEC 1.5/4...	Connector, redundant power supply, side base for power bussing, black
1915699	ZEC 1.0/6...	Connector, redundant power supply, side base for power bussing, green
2800755	PT 2X2-FF-ST	Protective plug for surge protector (not included with field junction box)
2839402	PT 4-BE	Surge base, with direct bridge between shield and rail ground
2839415	PT 4+F-BE	Surge base, with gas-filled surge arrestor between shield and rail ground (included with each field junction box)
2800034	S-PT-EX-24DC	Surge instrument, threaded pipe, M20 (other threads available)
2880671	S-PT-EX(I)-24DC	Surge instrument, threaded in-line pipe, M20 (other threads available)
2900197	FB-M-KV...	Cable gland, M20, NPB, silicone, 4.0-8.4 mm OD unarmoured, with nut, Ex e
2900209	FB-M-BS...	Blind stop plug, M20, NPB, silicone, with nut, Ex e
2901859	FB-M-BD...	Breather drain, M20, SST, silicone, with nut, Ex e
0819217	UC-TM 16	UniCard marker, for redundant power supply base
0819262	UC-TMF 16	UniCard marker, for redundant power supply base
0800377	WMS 9.5...	Heat-shrink markers on roll
3022218	CLIPFIX 35	End bracket for rail assemblies
2713780	E/ME TBUS...	End bracket for rail assemblies with T-bus protusion
3044076	UT 2.5	Terminal block (included with small field junction boxes)
3047028	D-UT 2.5/10	Terminal block cover
3200030	AI 1-8 RD	Ferrule for Type A fieldbus cable
143...	SAC-4P...	Fieldbus cordsets, various styles, angles, colours, and lengths
143...	SAC-2P...	Fieldbus Type A cable on reel, various colours
2866763	QUINT-PS...	Bulk power supply, 10 A
2320173	QUINT-ORING...	Auto current balancing redundancy module for bulk power
2320225	QUINT-UPS...	Smart DC UPS
2320319	QUINT-BAT...	Battery for DC UPS

Wireless Communication

RAD Line Wireless for Interzone Data Exchange

The Trusted Wireless technology used in RAD Line Wireless modules was especially developed for industrial applications. Thanks to the FHSS (Frequency Hopping Spread Spectrum) method, the technology attains proper ruggedness and is immune to interference. Communication is established on selected channels of the license-free 2.4 GHz (900 MHz) frequency band with pseudo random hopping and cyclic repetition.

Trusted Wireless advantages:

- Wide range of a few hundred meters up to typically 3 km (900 MHz: 20 miles)
- Rugged and reliable communication in a harsh industrial environment
- Can be operated in parallel with WLAN 802.11 and Bluetooth systems without interference RAD Line devices can be easily monitored and put into operation to serve the following applications:

RAD-Line IO for monitoring/monitoring and control of IO signals

- No programming required
- Outdoor variants for direct outdoor installation
- Point to Point and Multi-Point to Point variants

RAD Line Serial for monitoring and control of I/O signals and the RS232/422/485 interface.

GSM - Effective Connections Worldwide

PSI modems are specifically designed to meet industrial requirements for remote monitoring and alarm generation. Cables can be saved and thus several pipeline stations can be connected to a control room quickly and easily using modern GSM modems.

Process data is safely and permanently transmitted to the control room via GPRS connections. Malfunctions can be quickly and economically checked online, via the GSM mobile wireless global network. Dial-up line connections are typically used for remote monitoring.

An individual group of recipients is informed about the current occurrences through the warning or alarm inputs via text messages. Startup of all modems is simple with Plug & Play and a convenient configuration software. The modems have been tested with the most common process control systems from various manufacturers and industrial PCs in numerous applications for remote monitoring.

In addition to the Ex Zone 1 variant, all RAD Line devices are certified for traversing zone limits for Zone 2 by default as per the 94/9/EG (ATEX) guidelines and IEXEx and can also be used internationally in potentially explosive areas.



The Ex barrier for the antenna line enables installation of standard antennas in the optimum position

For worldwide safe and reliable

- System and machine maintenance
- Production data acquisition
- Remote diagnostics
- Automatic alarm



Reliable transmission of process data via GSM modems

WirelessHART Gateway with Integrated WLAN

Extend the Reach of WirelessHart

A WirelessHART gateway typically connects to an Asset Management System (AMS) or host via RS-485 or Ethernet. This is very simple to install, but the control room is often further than the reach of WirelessHART, requiring long runs of network cable.

The RAD-WHG/WLAN-XD is a WirelessHART gateway with integrated 802.11b/g WLAN transceiver. It can connect up to 250 WirelessHART field devices and convert the HART data to Modbus TCP or HART UDP for easy integration into almost any host system, including the HART server.

The WLAN transceiver can also be disabled, and the host connection can be made via the standard Ethernet port.

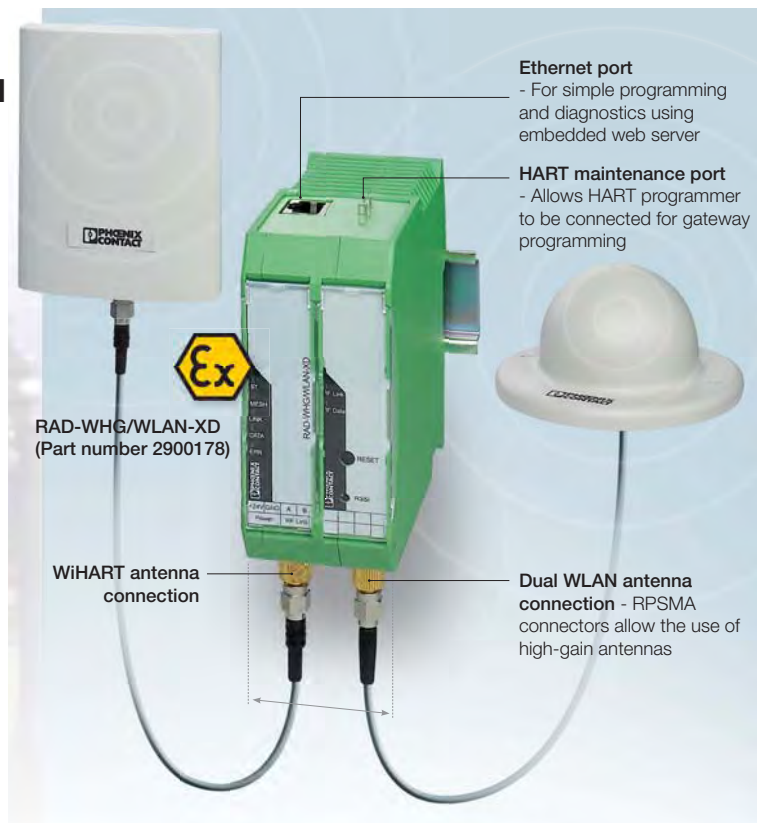

WirelessHART Adapter

Flexibility for Field Connections

The RAD-WHA-1/2NPT is a WirelessHART adapter designed to connect up to four HART devices for the wireless transmission of HART data.

The adapter can be connected in a series with a HART device (loop powered) or in parallel with up to four HART devices (24 V DC powered). When 24 V DC powered, the adapter is capable of supplying loop current to the HART devices.

The RAD-WHA-1/2NPT can also be connected to a single 4...20 mA device for the wireless transmission of the digitalised signal.

WirelessHART is a low cost, low risk alternative to installing multiplexers, as no re-work is necessary, and it provides rich diagnostics information about the status of the devices as well as the network.



Literature List:

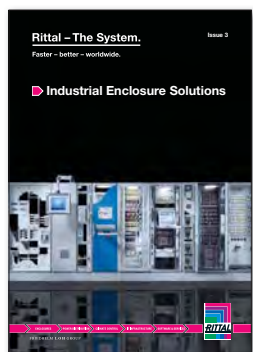

Industrial Enclosure Solutions:
A comprehensive overview of Rittal's complete range of industrial enclosure solutions.



Rittal Data Centre Solutions:
The simple route to the perfect data centre.



Highlights 2013:
Phoenix Contact core products and innovations of 2013.



Explosion Protection:
A comprehensive guide to understanding how and why explosions occur and how to protect against them.



HEAD OFFICE AUSTRALIA

130-140 Parraweena Road,
Miranda NSW 2228 Australia

T Rittal - 1800 350 665

Phoenix Contact - 1300 786 411

E customerservice@rittal.com.au

customerservice@phoenixcontact.com.au

W rittal.com.au

rittaldatacentre.com.au

phoenixcontact.com.au

HEAD OFFICE NEW ZEALAND

21 Bell Road South, Lowerhutt, Wellington NZ

T Rittal - 04 566 7630

Phoenix Contact - 0508 746 364

E sales@rittal.co.nz

sales@phoenixcontact.co.nz

W rittal.co.nz

rittaldatacentre.co.nz

phoenixcontact.co.nz

