

# **Rittal – The System.**

Faster – better – everywhere.



**Koppelfeld Dachbereich Horizontal-Anschluss (Kapitel A.6)**

**Coupling set, roof area – Horizontal connection (chapter A.6)**

**Zone de raccordement – jeu de barres sous le toit – raccordement horizontal (chaptre A.6)**

**Anhang VX25 Ri4Power – Montageanleitung**

**Appendix VX25 Ri4Power – Assembly instructions**

**Annexe VX25 Ri4Power – Notice de montage**

ENCLOSURES

POWER DISTRIBUTION

CLIMATE CONTROL

IT INFRASTRUCTURE

SOFTWARE & SERVICES

FRIEDHELM LOH GROUP



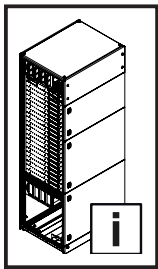

**Inhaltsverzeichnis**  
**Contents**  
**Sommaire**

DE

EN

FR

<b>1. Montage 4-poliges HSS</b>	<b>7</b>
1.1 Leistungsschalterfeld 600 mm tief / Hauptsammelschiene im Dachbereich	7
1.2 Vorbereitung Modulschrank	8
1.3 Vorbereitung Tragschiene Leistungsschalter	9
1.4 Vorbereitung Funktionsraum-Seitenwand	12
1.5 Montage linke Funktionsraum-Seitenwand	14
1.6 Montage rechte Funktionsraum-Seitenwand	16
1.7 Montage des PE-/PEN-Sammelschienen-systems	18
1.8 Montage des N-Sammelschienen-systems	19
1.9 Montage des oberen Hauptschienen-systems	21
1.10 Montage des unteren Hauptschienen-systems	24
1.11 Montage des offenen Leistungsschalters	28
1.12 Montage des offenen Leistungsschalters – oberer Verbindungssatz	33
1.13 Montage des offenen Leistungsschalters – unterer Verbindungssatz	41
1.14 Montage des offenen Leistungsschalters – Anziehen der Schrauben	48
1.15 Montage Funktionsraumteiler	50
1.16 Montage der Teilmontageplatte	55
<b>2. Montage Hochführungsfeld</b>	<b>59</b>
2.1 Hochführungsfeld 600 mm tief	59
2.2 Vorbereitung Modulschrank	60
2.3 Montage untere System-Chassis	61
2.4 Montage untere Sammelschienenhalter horizontal	65
2.5 Einbringung vertikale Verteilsammel-schienen	70
2.6 Montage obere System-Chassis und Sammelschienenhalter	71
2.7 Montage des oberen Hauptschienen-systems	75
2.8 Anbindung vertikales Verteilsammel-schienen-system	78
2.9 Montage des PE-/PEN-Sammelschienen-systems	80
2.10 Montage des N-Sammelschienen-systems	81
<b>3. Verbindung ACB- und Hochführungsfeld</b>	<b>83</b>
3.1 Verbindung des ACB- und des Hoch-führungsfelds	83
3.2 Vorbereitung Sammelschienen-system – Einführen der Längsverbinder	84
3.3 Zusammenfügen der Schaltanlagenfelder – Montage der Anreihverbinder	86
3.4 Verschrauben der Längsverbinder	89
<b>4. Modulare Frontgestaltung</b>	<b>92</b>
4.1 Montage Frontblenden, Teiltüren, Dach-bleche und Rückwände	92
<b>5. Montage 3-poliges HSS</b>	<b>93</b>
5.1 Besonderheiten ACB-Feld	93
5.2 Besonderheiten Hochführungsfeld	96
5.3 Übersicht 3-poliges HSS	97
<b>6. Stabilisierung verschiedener Laschenhöhen des offenen Leistungsschalters</b>	<b>98</b>
<b>7. Hauptsammelschienen-system 4 x 30 x 10</b>	<b>100</b>
7.1 Montage Hochführungsfeld – Anbindung vertikales Verteilsammelschienen-system	100

<b>1. Fitting the 4-pole MBS</b>	<b>7</b>
1.1 Air circuit-breaker section 600 mm deep / main busbar in the roof area	7
1.2 Preparing the modular enclosure	8
1.3 Preparing the support rail for the ACB	9
1.4 Preparing the compartment side panel	12
1.5 Fitting the left functional space side panel	14
1.6 Fitting the right functional space side panel	16
1.7 Fitting the PE/PEN busbar system	18
1.8 Fitting the N busbar system	19
1.9 Fitting the upper main busbar system	21
1.10 Fitting the lower main busbar system	24
1.11 Fitting the circuit-breaker	28
1.12 Fitting the circuit-breaker – Upper con- nector kit	33
1.13 Fitting the circuit-breaker – Lower con- nector kit	41
1.14 Fitting the circuit-breaker – Tightening the screws	48
1.15 Fitting the compartment divider	50
1.16 Fitting the partial mounting plate	55
<b>2. Fitting the riser section</b>	<b>59</b>
2.1 Riser section 600 mm deep	59
2.2 Preparing the modular enclosure	60
2.3 Fitting the lower punched sections with mounting flanges	61
2.4 Fitting the lower busbar supports, horizontal	65
2.5 Incorporating the vertical distribution busbars	70
2.6 Fitting the upper punched sections with mounting flanges and busbar supports	71
2.7 Fitting the upper main busbar system	75
2.8 Connecting the vertical multi-terminal busbar system	78
2.9 Fitting the PE/PEN busbar system	80
2.10 Fitting the N busbar system	81
<b>3. Connecting the air circuit-breaker (ACB) and riser section</b>	<b>83</b>
3.1 Connecting the ACB and riser section	83
3.2 Preparing the busbar system – Inserting the longitudinal connectors	84
3.3 Joining the switchgear sections together – Fitting the baying connectors	86
3.4 Screw-fastening the longitudinal connec- tors	89
<b>4. Modular front design</b>	<b>92</b>
4.1 Fitting the front panels, partial doors, roof panels and rear panels	92
<b>5. Fitting the 3-pole MBS</b>	<b>93</b>
5.1 Special features – ACB section	93
5.2 Special features – Riser section	96
5.3 Overview of 3-pole main busbar system	97
<b>6. Stabilising different circuit-breaker connector heights</b>	<b>98</b>
<b>7. Main busbar system 4 x 30 x 10</b>	<b>100</b>
7.1 Fitting the riser section – Connecting the vertical multi-terminal busbar system	100
7.2 Preparing the busbar system – Inserting the longitudinal connectors	102
7.3 Joining the switchgear sections together – Fitting the baying connectors	103

<b>1. Montage des JBP tétrapolaires</b>	<b>7</b>
1.1 Zone des disjoncteurs de puissance d'une profondeur de 600 mm / jeu de barres principal sous le toit	7
1.2 Préparation de l'armoire modulaire	8
1.3 Préparation du rail porteur pour disjonc- teur de puissance	9
1.4 Préparation du panneau latéral de com- partiment fonctionnel	12
1.5 Montage du panneau latéral de comparti- ment fonctionnel à gauche	14
1.6 Montage du panneau latéral de comparti- ment fonctionnel à droite	16
1.7 Montage des jeux de barres Terre / Terre- Neutre	18
1.8 Montage des jeux de barres Neutre	19
1.9 Montage des jeux de barres principaux supérieurs	21
1.10 Montage des jeux de barres principaux inférieurs	24
1.11 Montage du disjoncteur de puissance	28
1.12 Montage du disjoncteur de puissance – kit de jonction supérieur	33
1.13 Montage du disjoncteur de puissance – kit de jonction inférieur	41
1.14 Montage du disjoncteur de puissance – serrage des vis	48
1.15 Montage de la cloison fonctionnelle	50
1.16 Montage de la plaque de montage partielle	55
<b>2. Montage de zone d'installation verticale</b>	<b>59</b>
2.1 Zone d'installation verticale d'une profon- deur de 600 mm	59
2.2 Préparation de l'armoire modulaire	60
2.3 Montage sous rails de montage	61
2.4 Montage des supports de jeux de barres horizontaux inférieurs	65
2.5 Introduction des jeux de barres de distri- bution verticaux	70
2.6 Montage des rails de montage supérieurs et des supports de jeux de barres	71
2.7 Montage des jeux de barres principaux supérieurs	75
2.8 Connexion aux jeux de barres de distribu- tion verticaux	78
2.9 Montage des jeux de barres Terre / Terre- Neutre	80
2.10 Montage des jeux de barres Neutre	81
<b>3. Connexion du disjoncteur de puis- sance et de la zone d'installation verticale</b>	<b>83</b>
3.1 Connexion du disjoncteur de puissance et de la zone d'installation verticale	83
3.2 Préparation des jeux de barres – introduc- tion des éléments de jonction longitudinaux	84
3.3 Assemblage des différentes cellules de distribution électrique – montage des attaches de juxtaposition	86
3.4 Vissage des éléments de jonction longitu- dinaux	89
<b>4. Aménagement modulaire de la face avant</b>	<b>92</b>
4.1 Montage des bandeaux de finition avant, portes partielles, toits et panneaux arrière	92

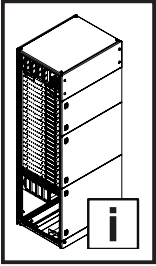

# Inhaltsverzeichnis

## Contents

## Sommaire

DE

7.2	Vorbereitung Sammelschienensystem – Einführen der Längsverbinder	102
7.3	Zusammenfügen der Schaltanlagenfelder – Montage der Anreihverbinder	103
7.4	Verschrauben der Längsverbinder	104
	<b>Artikelverzeichnis</b>	<b>105</b>

EN

7.4	Screw-fastening the longitudinal connectors	104
	<b>List of model numbers</b>	<b>105</b>

FR

<b>5.</b>	<b>Montage des JBP tripolaires</b>	<b>93</b>
5.1	Particularités – zone des disjoncteurs de puissance	93
5.2	Particularités – zone d'installation verticale	96
5.3	Vue d'ensemble des jeux de barres principaux tripolaires	97
<b>6.</b>	<b>Stabilisation de différents raccordements de disjoncteurs de puissance</b>	<b>98</b>
<b>7.</b>	<b>Jeux de barres principaux 4 x 30 x 10</b>	<b>100</b>
7.1	Montage de zone d'installation verticale – connexion aux jeux de barres de distribution verticaux	100
7.2	Préparation des jeux de barres – introduction des éléments de jonction longitudinaux	102
7.3	Assemblage des différentes cellules de distribution électrique – montage des attaches de juxtaposition	103
7.4	Vissage des éléments de jonction longitudinaux	104
	<b>Liste des références</b>	<b>105</b>

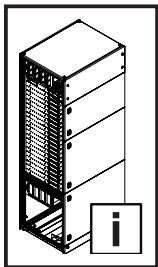

**Inhaltsverzeichnis**  
**Contents**  
**Sommaire**

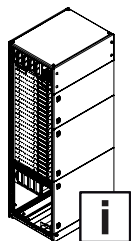

2-7  
98-99  
105-106

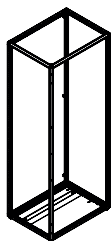

8

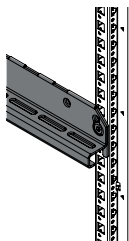

9-11

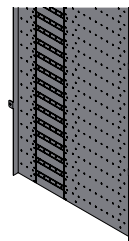

12-13

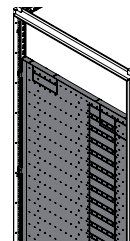

14-15

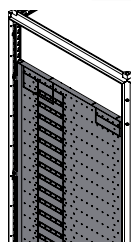

16-17

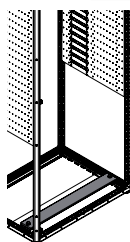

18

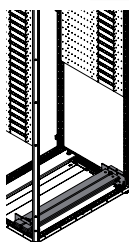

19-20

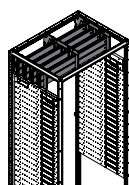

21-23

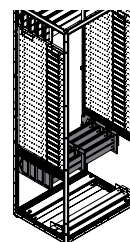

24-27

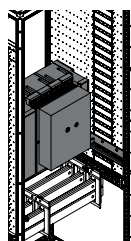

28-32

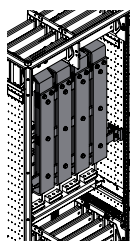

33-40

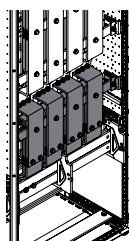

41-47

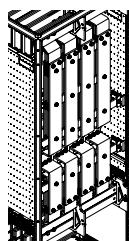

48-49

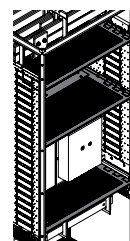

50-54

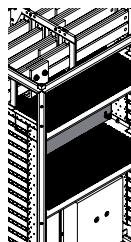

55-58

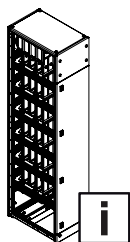

59

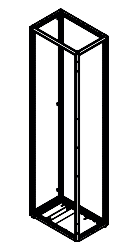

60

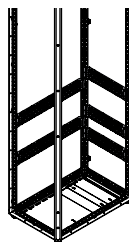

61-64

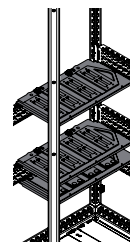

65-69

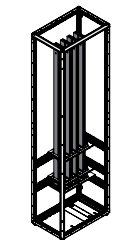

70

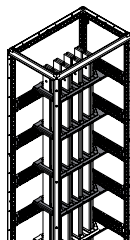

71-74

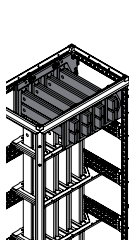

75-77

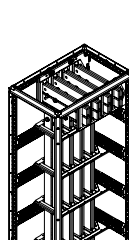

78-79

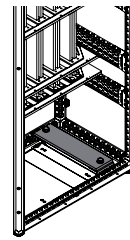

80

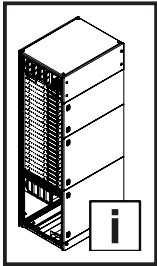

Inhaltsverzeichnis  
Contents  
Sommaire

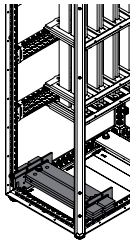

81-82

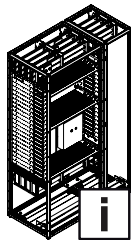

83

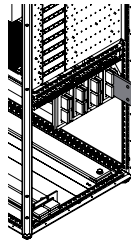

84-85

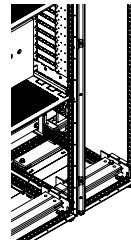

86-88

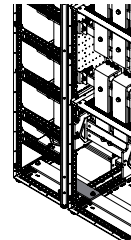

89-91

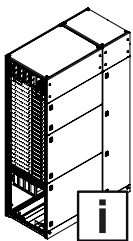

92

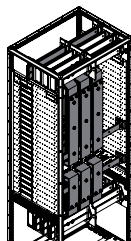

93-95

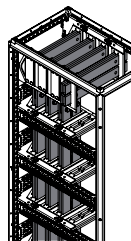

96

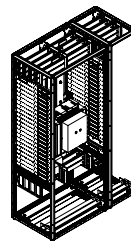

97

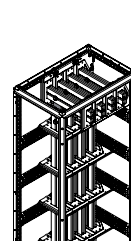

100-101

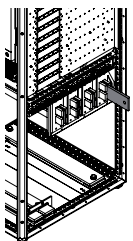

102

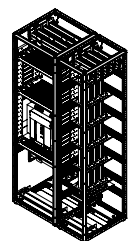

103

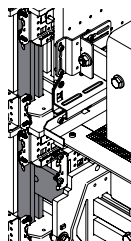

104

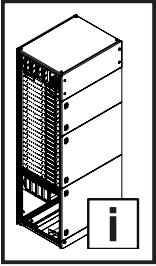

## Mitgeltende Unterlagen Other applicable documents Autres documents applicables

DE

Für die hier beschriebenen Sammelschienenkomponenten steht diese Montageanleitung als Download unter [www.rittal.de](http://www.rittal.de) zur Verfügung. Für Schäden, die durch Nichtbeachtung dieser Anleitung entstehen, übernehmen wir keine Haftung. Zusätzlich gelten auch die Anleitungen des verwendeten Zubehörs sowie die VX25 Ri4Power Montageanleitung.

Bitte beachten Sie die Sicherheits- und Warnhinweise in der Montageanleitung „VX25 Ri4Power – Schalt- und Energieverteilanlagen-System“.

### Montageanleitung VX25 Ri4Power – Schalt- und Energieverteilanlagen-System

### Assembly instructions VX25 Ri4Power – Switchgear and power distribution system

### Notice de montage VX25 Ri4Power – Distribution de courant

 **DE/EN/FR**

EN

These assembly instructions for the described busbar components can be downloaded from [www.rittal.com](http://www.rittal.com). We cannot accept any liability for damage associated with failure to observe these instructions. The instructions for any accessories used, together with the VX25 Ri4Power assembly instructions, also apply.

Please observe the safety and warning notes in the “VX25 Ri4Power – Switchgear and power distribution system” assembly instructions.

FR

La présente notice de montage pour les composants du jeu de barres mentionnés ici peut être téléchargée sur le site internet [www.rittal.fr](http://www.rittal.fr). Nous déclinons toute responsabilité en cas de dommages imputables à la non-observation des instructions contenues dans ce document. Veuillez également respecter les instructions relatives aux accessoires utilisés ainsi que la notice de montage VX25 Ri4Power.

Veuillez respecter les consignes de sécurité et les avertissements figurant dans les instructions de montage « VX25 Ri4Power – Distribution de courant ».

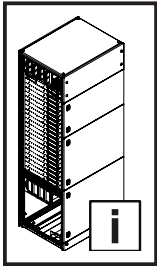

**1. Montage 4-poliges HSS**  
**1. Fitting the 4-pole MBS**  
**1. Montage des JBP tétrapolaires**

- 1.1 Leistungsschalterfeld 600 mm tief / Hauptsammelschiene im Dachbereich
- 1.1 Air circuit-breaker section 600 mm deep / main busbar in the roof area
- 1.1 Zone des disjoncteurs de puissance d'une profondeur de 600 mm / jeu de barres principal sous le toit

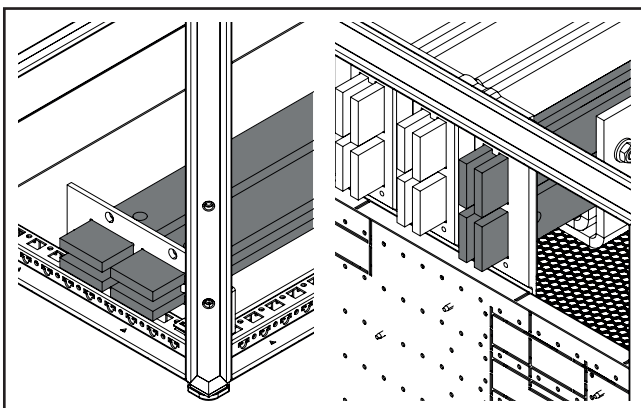
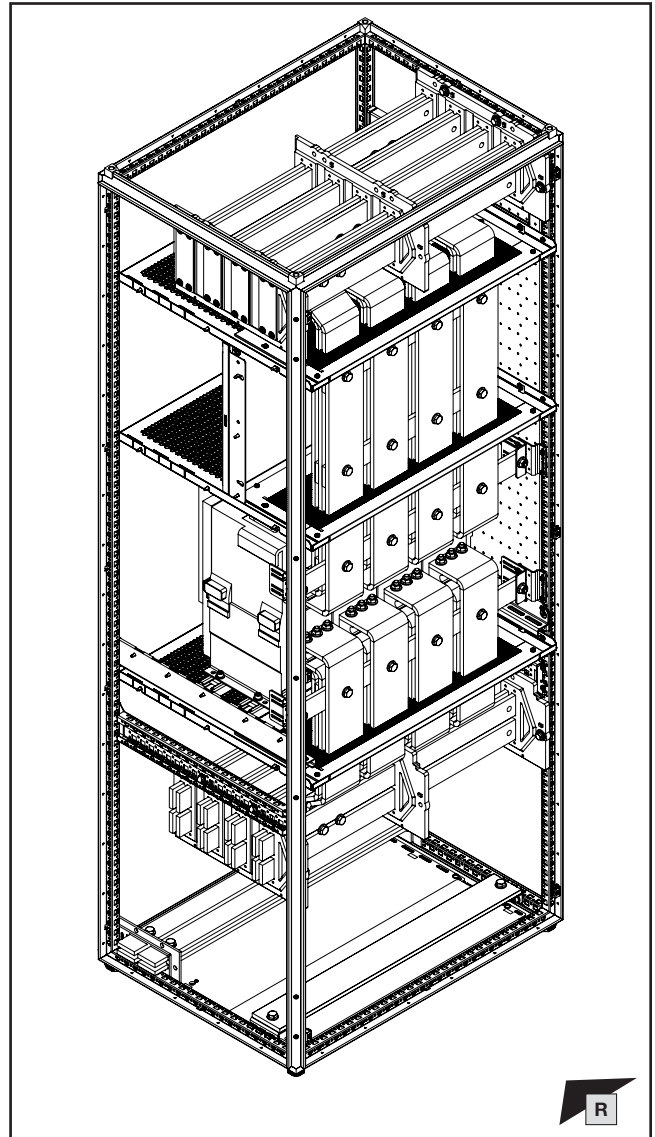
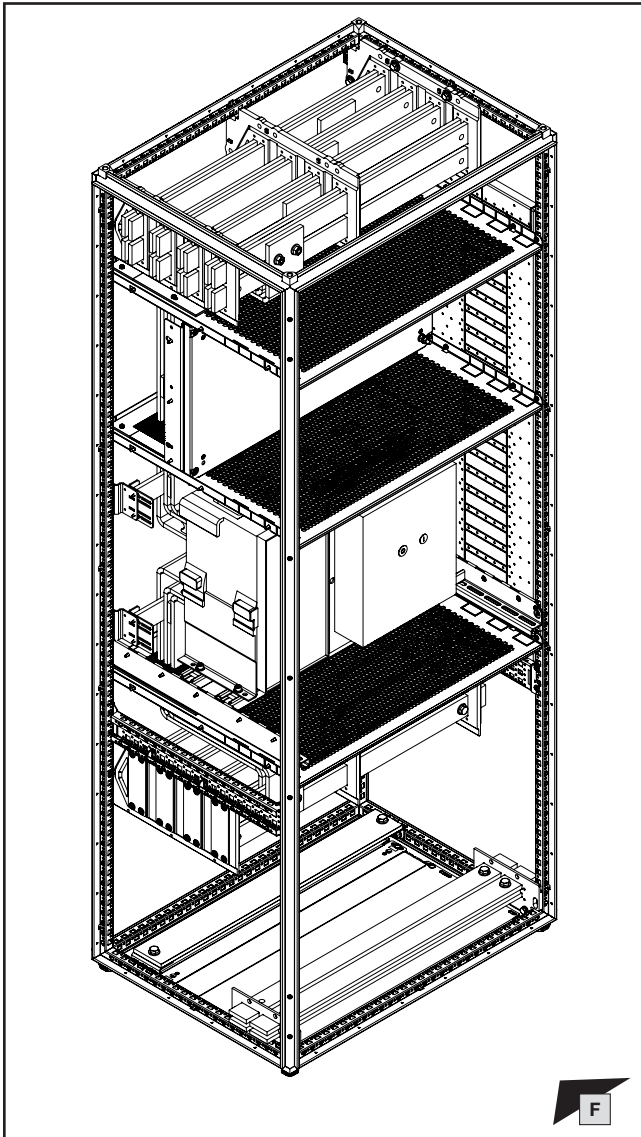

**Hinweis / Note / Remarque**

Neutralleiter N nach Wahl des Anlagenbetreibers im Bodenbereich oder im Dachbereich (siehe Kapitel 5). Montage beider Varianten wird im Kapitel 1 parallel gezeigt.

Neutral conductor N as chosen by the plant operator in the floor area or in the roof area (see chapter 5). The assembly of both variants is shown in parallel in chapter 1.

Neutre N dans la base ou sous le toit, selon le choix de l'exploitant de l'installation (voir chapitre 5). Le montage des deux variantes est décrit au chapitre 1.

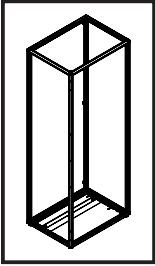

1. Montage 4-poliges HSS  
 1. Fitting the 4-pole MBS  
 1. Montage des JBP tétrapolaires

- 1.2 Vorbereitung Modulschrank
- 1.2 Preparing the modular enclosure
- 1.2 Préparation de l'armoire modulaire

Montageanleitung VX25 Ri4Power – Schalt- und Energieverteilanlagen-System  
 Assembly instructions VX25 Ri4Power – Switchgear and power distribution system  
 Notice de montage VX25 Ri4Power – Distribution de courant

DE/EN/FR

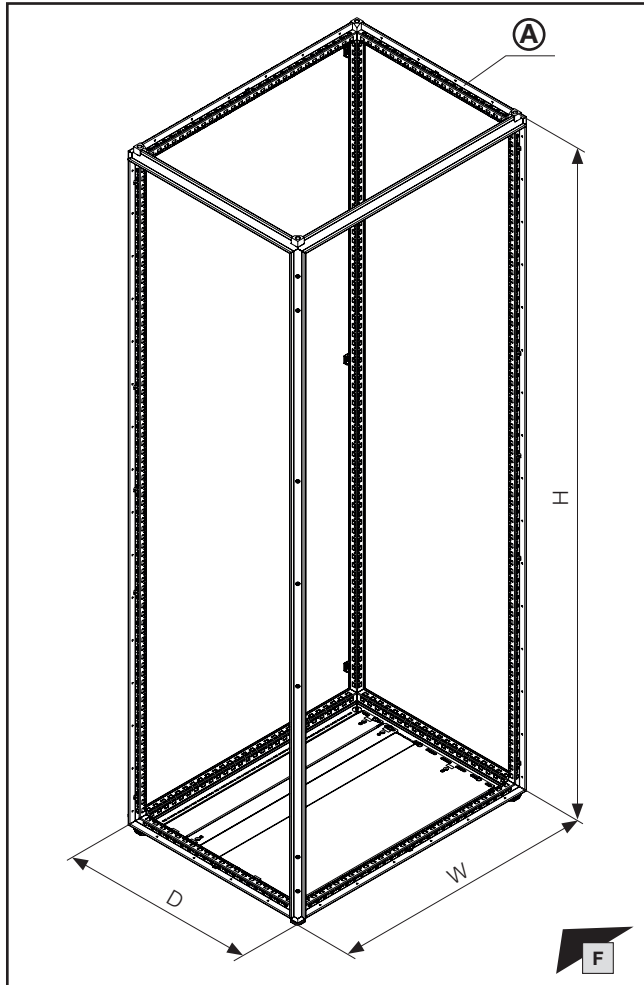

**Hinweis / Note / Remarque**  
 Die Angaben „W“ (Breite), „H“ (Höhe) und „D“ (Tiefe) der Schränke beziehen sich jeweils auf die nominalen Abmessungen der Schränke.  
 The information "W" (width), "H" (height) and "D" (depth) each refer to the nominal dimensions of the enclosures.  
 Les informations « W » (largeur), « H » (hauteur) et « D » (profondeur) se réfèrent chacune aux dimensions nominales des armoires.

**Hinweis / Note / Remarque**  
 Vorbereitende Arbeiten: siehe o. g. Anleitung, Kapitel „Demontage Flachteile“ und „Vorbereitung Montage Frontblenden“.  
 Preparatory work: see above mentioned assembly instructions, chapter "Dismantling panels" and "Preparation of mounting front trim panels".  
 Pour les travaux préliminaires, voir les chapitres « Démontage des pièces plates » et « Préparation du montage des faces avant » de la notice de montage ci-dessus.

**Hinweis / Note / Remarque**  
 Für Schutz Eigenschaft Störlichtbogenklasse A/B Montagereihenfolge in den entsprechenden Kapiteln der o. g. Anleitung beachten.  
 For arcing class A/B protection, please follow the assembly sequence as set out in the relevant chapters of the aforementioned assembly instructions.  
 Pour la protection contre les arcs électriques de catégorie A/B, suivez la séquence de montage indiquée dans les chapitres correspondantes des instructions ci-dessus.

W mm	H mm	D mm	A Best.-Nr. Model No. Référence
400	2000	600	9680.406
400	2000	800	9680.408
400	2200	600	9680.426
400	2200	800	9680.428
600	2000	600	9680.606
600	2000	800	9680.608
600	2200	600	9680.626
600	2200	800	9680.628
800	2000	600	9680.806
800	2000	800	9680.808
800	2200	600	9680.826
800	2200	800	9680.828
1000	2000	800	9680.008
1000	2200	800	9680.028
1200	2000	800	9680.208
1200	2200	800	9680.228

**Hinweis / Note / Remarque**  
 Alternativ: Basisschrank aus Produktauswahl „Anreih-Schranksystem VX25“.  
 Option: Basic enclosure from the "baying enclosure system VX25" product selection.  
 Option : armoire électrique juxtaposable VX25 classique.

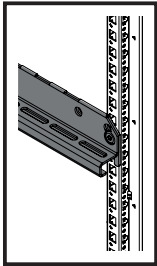

1. Montage 4-poliges HSS  
 1. Fitting the 4-pole MBS  
 1. Montage des JBP tétrapolaires

- 1.3 Vorbereitung Tragschiene Leistungsschalter
- 1.3 Preparing the support rail for the ACB
- 1.3 Préparation du rail porteur pour disjoncteur de puissance

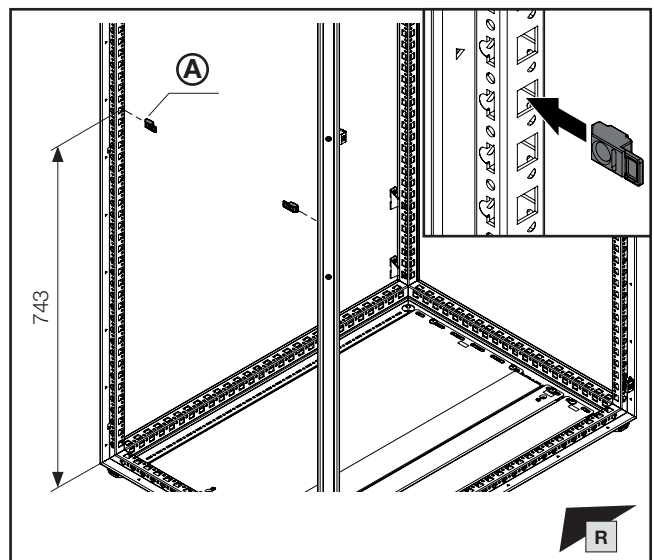
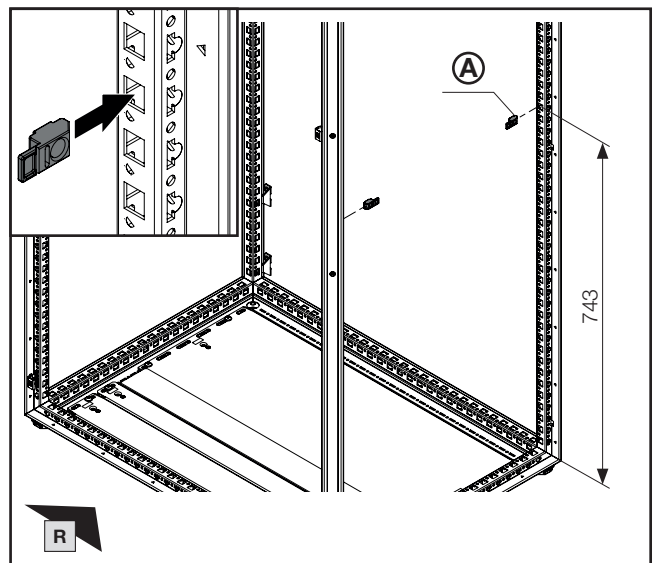
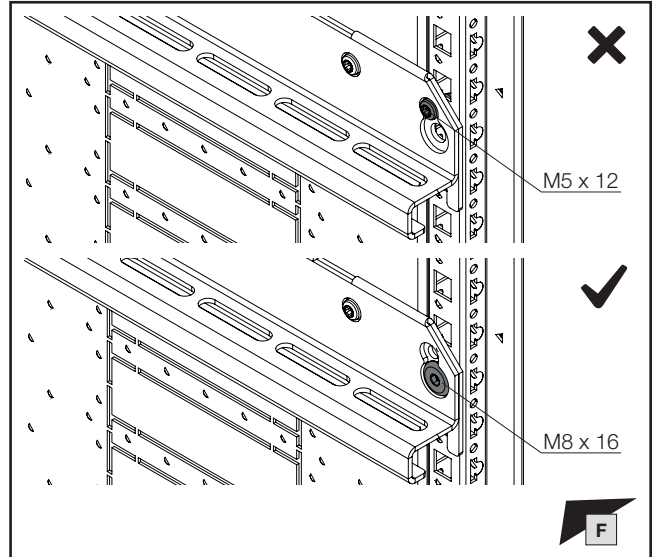
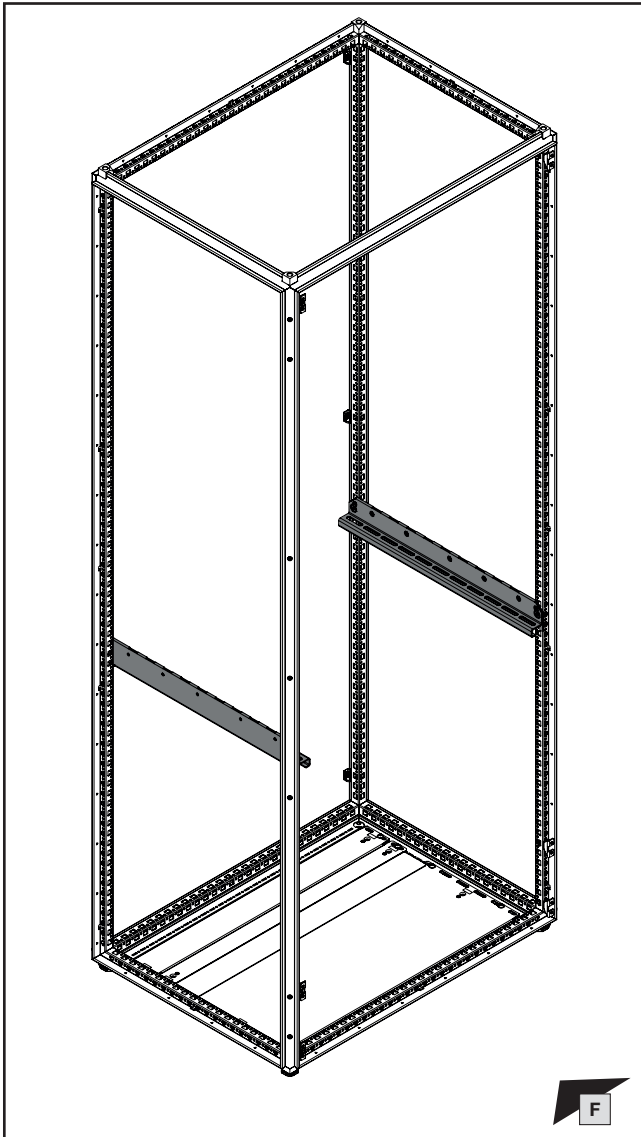

**Hinweis / Note / Remarque**  
 Arbeitsschritte notwendig für größte Belastung der Tragschienen. Einlegezettel beachten!  
 Steps required for maximum loading of the support rails. Observe the instruction sheet!  
 Étapes requises pour une charge maximale des rails porteurs. Respecter les fiches jointes !

D mm	(A) Best.-Nr. Model No. Référence
600	9683.326
800	9683.328

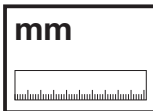
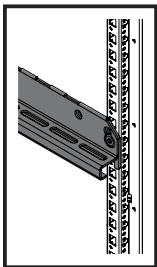

- 1. Montage 4-poliges HSS
- 1. Fitting the 4-pole MBS
- 1. Montage des JBP tétrapolaires

- 1.3 Vorbereitung Tragschiene Leistungsschalter
- 1.3 Preparing the support rail for the ACB
- 1.3 Préparation du rail porteur pour disjoncteur de puissance

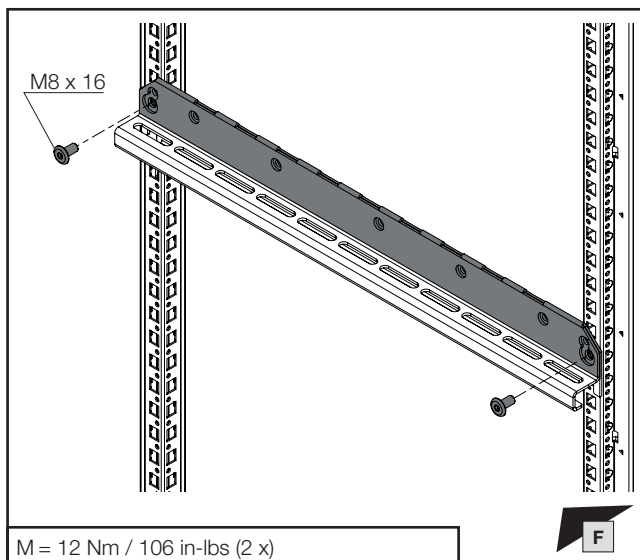
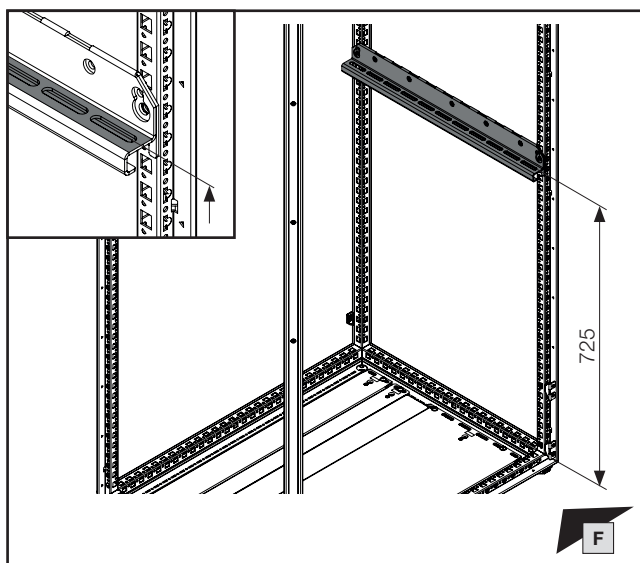
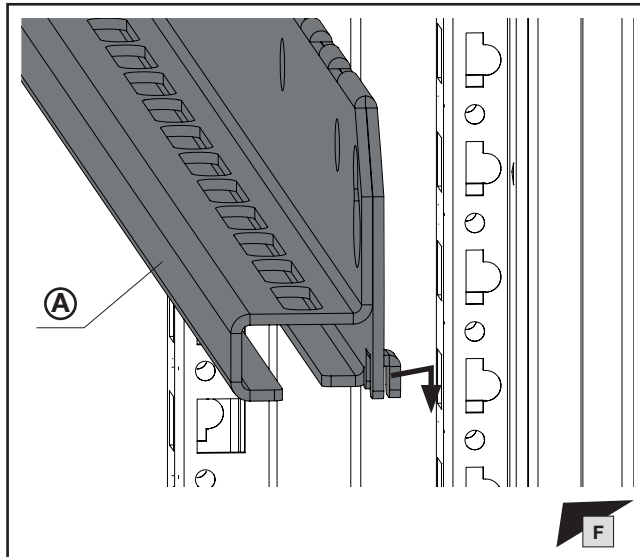
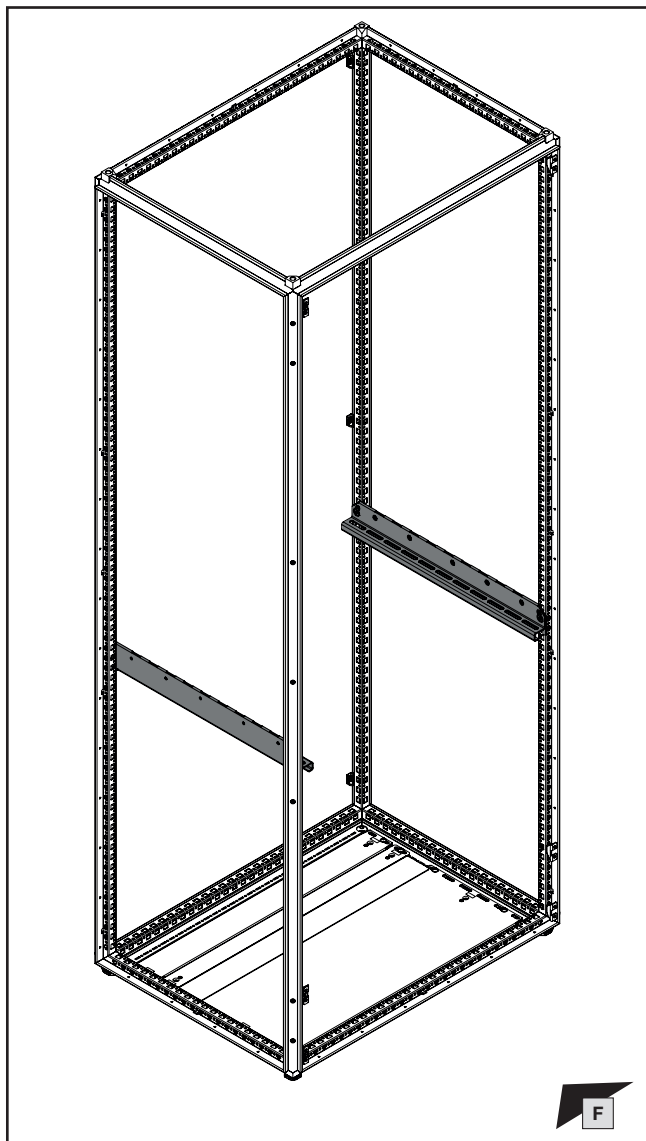

D mm	Ⓐ Best.-Nr. Model No. Référence
600	9683.326
800	9683.328

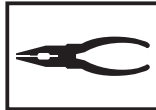
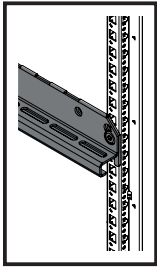

- 1. Montage 4-poliges HSS
- 1. Fitting the 4-pole MBS
- 1. Montage des JBP tétrapolaires

- 1.3 Vorbereitung Tragschiene Leistungsschalter
- 1.3 Preparing the support rail for the ACB
- 1.3 Préparation du rail porteur pour disjoncteur de puissance

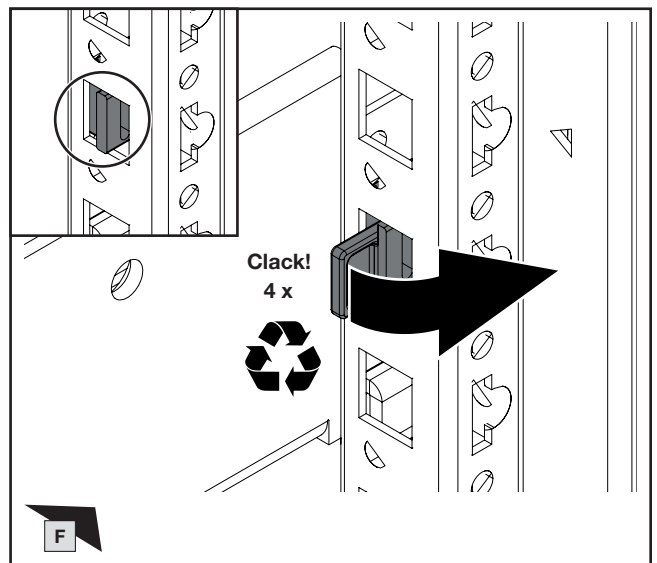
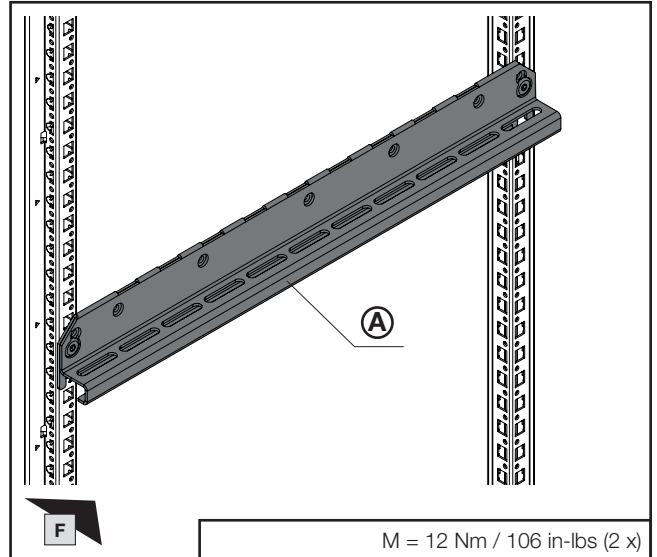
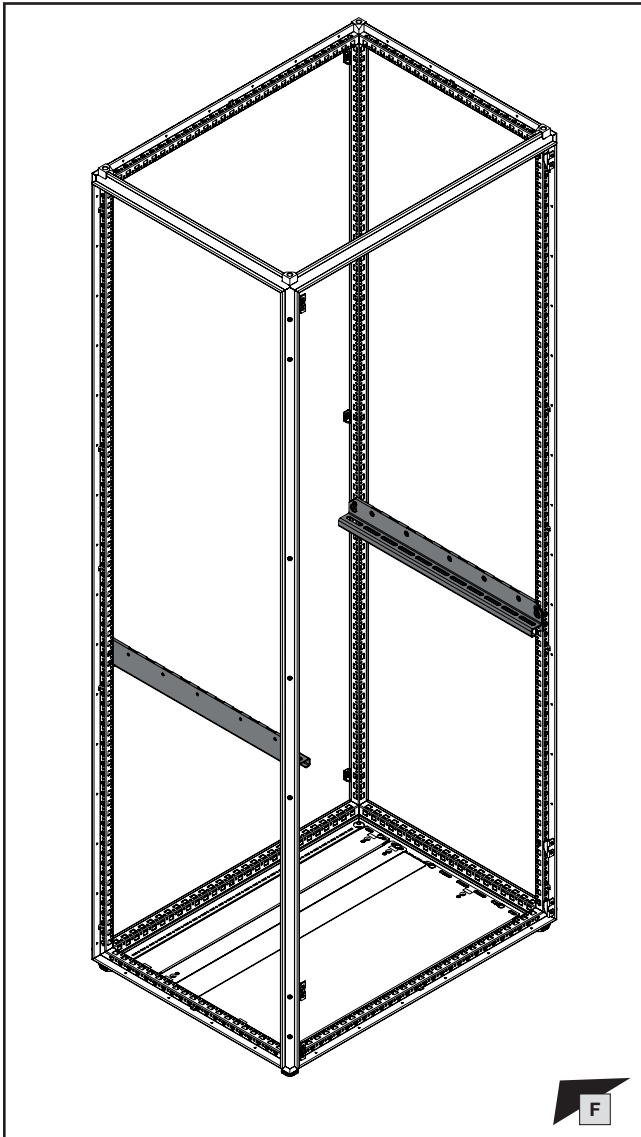

**Hinweis / Note / Remarque**

**Vollständige Montage des offenen Leistungsschalters:** siehe Kapitel 1.11.

**Full installation of the air circuit-breaker:** see chapter 1.11.

**Montage complet du disjoncteur de puissance :** voir chapitre 1.11.

D mm	Ⓐ Best.-Nr. Model No. Référence
600	9683.326
800	9683.328

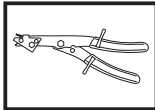
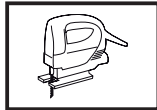
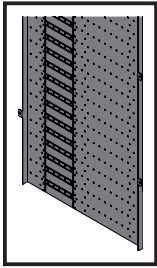

1. Montage 4-poliges HSS  
 1. Fitting the 4-pole MBS  
 1. Montage des JBP tétrapolaires

- 1.4 Vorbereitung Funktionsraum-Seitenwand
- 1.4 Preparing the compartment side panel
- 1.4 Préparation du panneau latéral de compartiment fonctionnel

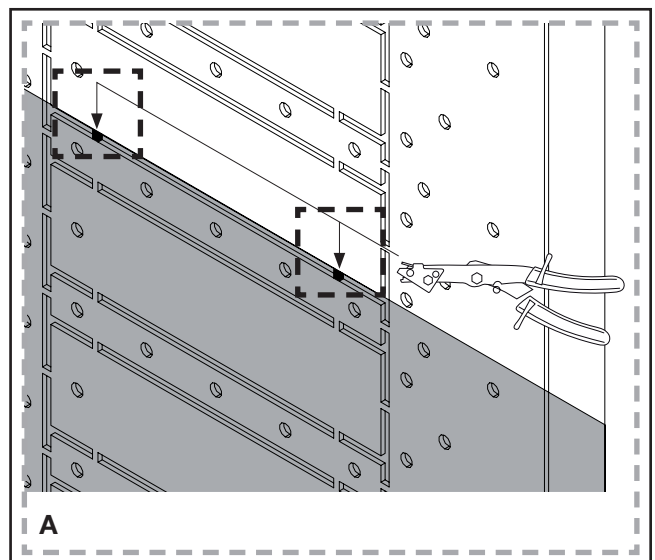
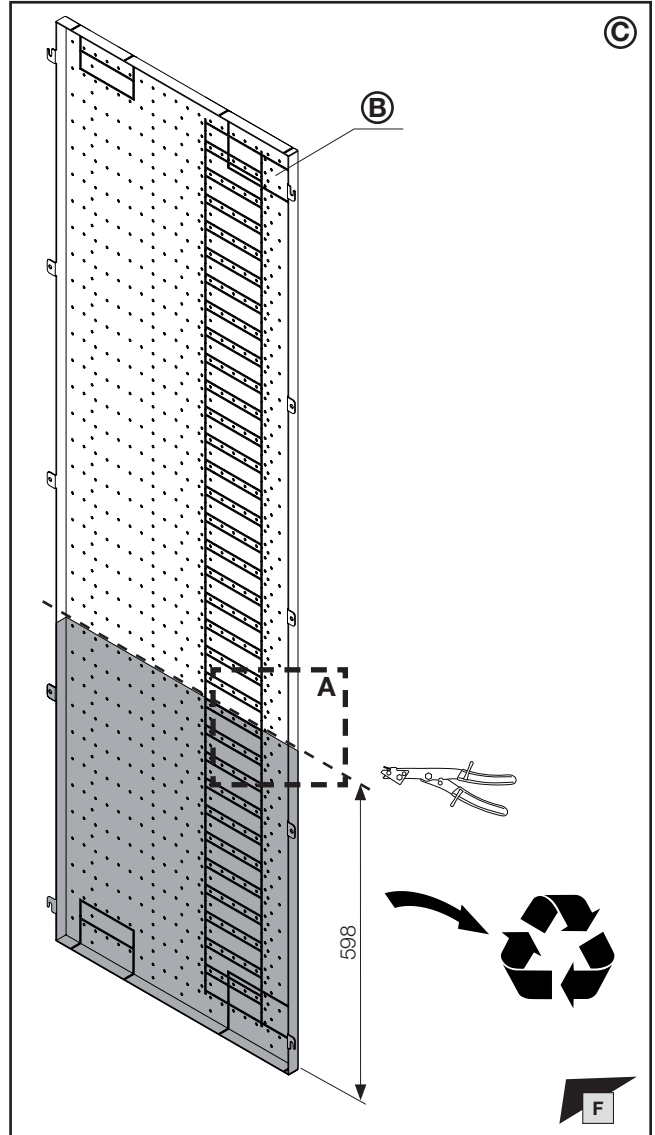
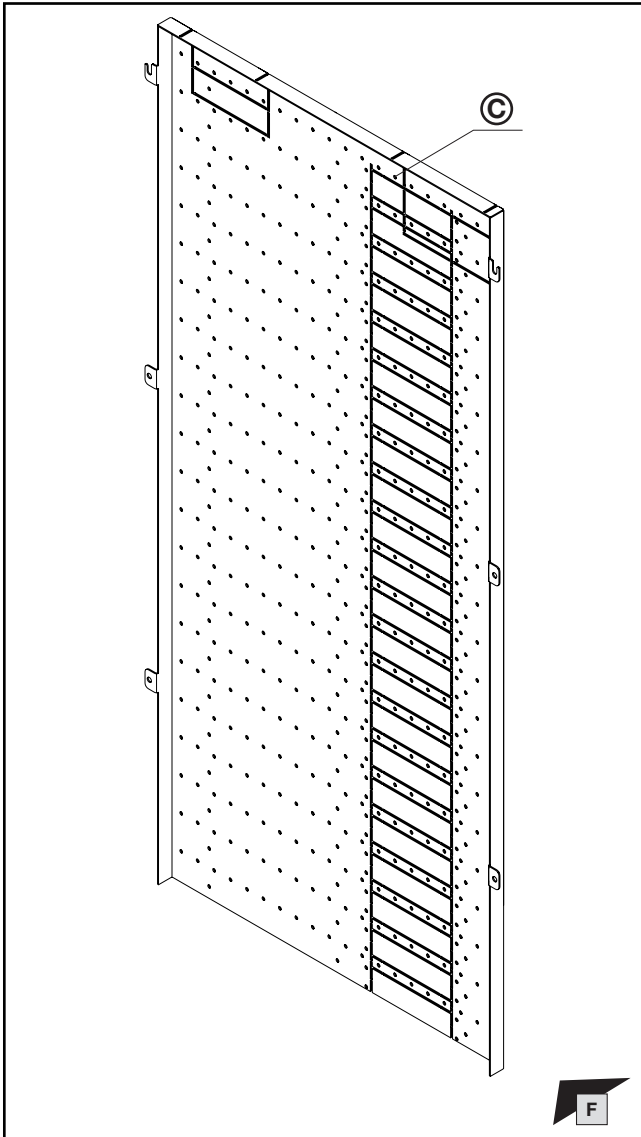

H x D mm	siehe Seite 14 see page 14 voir page 14	<b>(B)</b> Best.-Nr. Model No. Référence
2000 x 600		9683.016
2000 x 800		9683.018
2200 x 600		9683.036
2200 x 800		9683.038

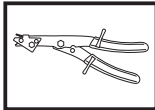
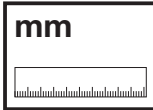
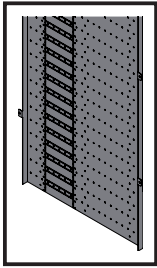

1. Montage 4-poliges HSS  
 1. Fitting the 4-pole MBS  
 1. Montage des JBP tétrapolaires

- 1.4 Vorbereitung Funktionsraum-Seitenwand
- 1.4 Preparing the compartment side panel
- 1.4 Préparation du panneau latéral de compartiment fonctionnel

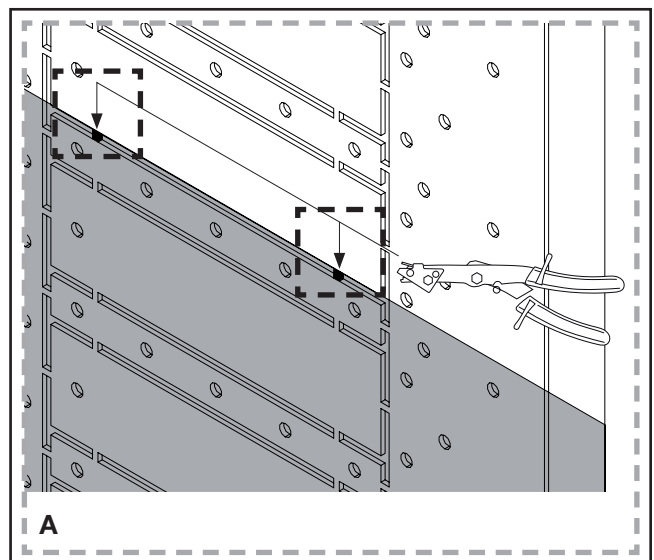
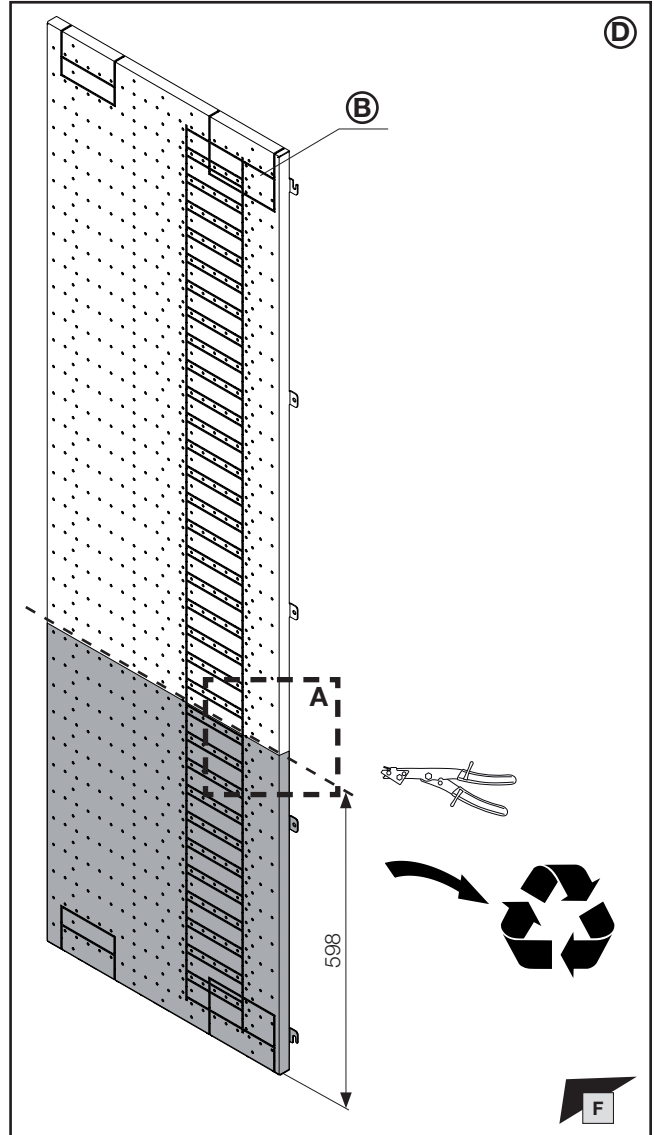
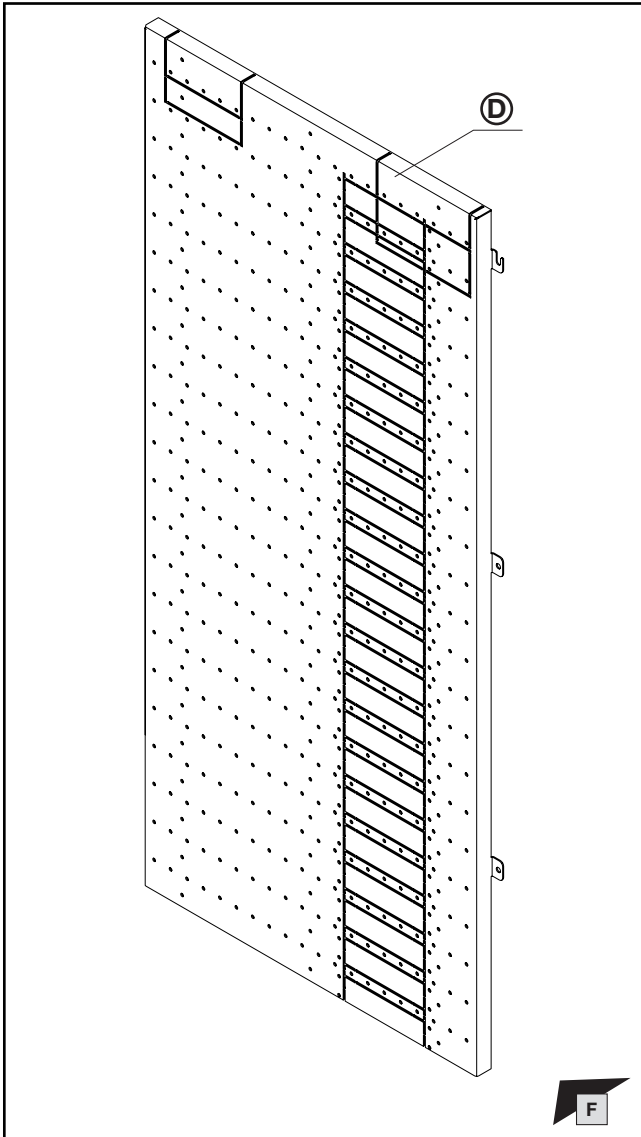

H x D mm	siehe Seite 16 see page 16 voir page 16	(B) Best.-Nr. Model No. Référence
2000 x 600		9683.016
2000 x 800		9683.018
2200 x 600		9683.036
2200 x 800		9683.038

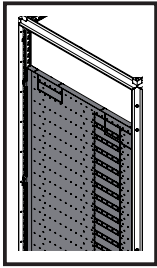

DE EN FR



1. Montage 4-poliges HSS  
 1. Fitting the 4-pole MBS  
 1. Montage des JBP tétrapolaires

- 1.5 Montage linke Funktionsraum-Seitenwand  
 1.5 Fitting the left functional space side panel  
 1.5 Montage du panneau latéral de compartiment fonctionnel à gauche

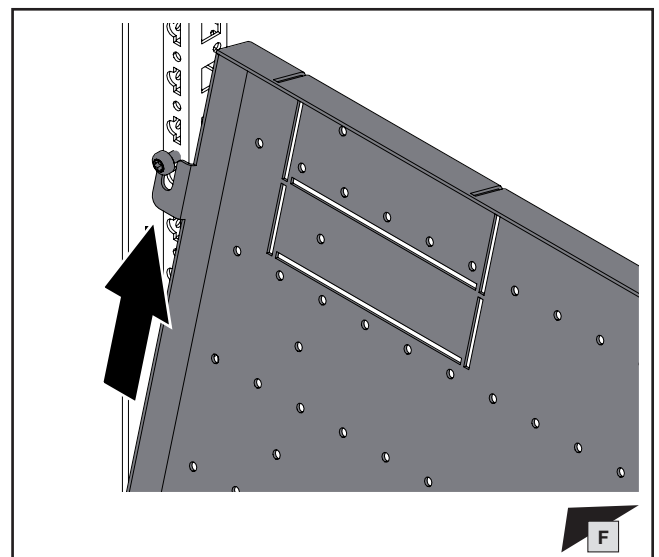
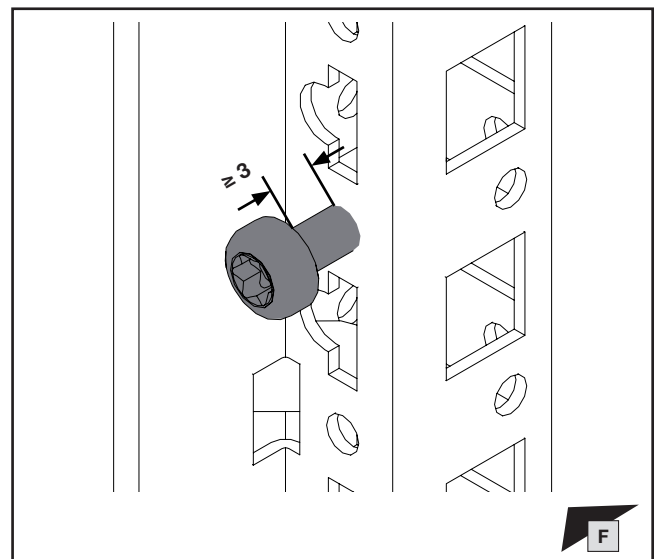
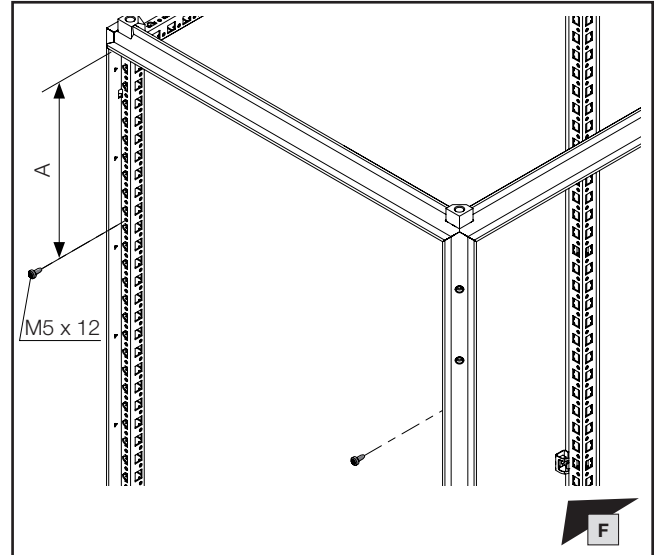
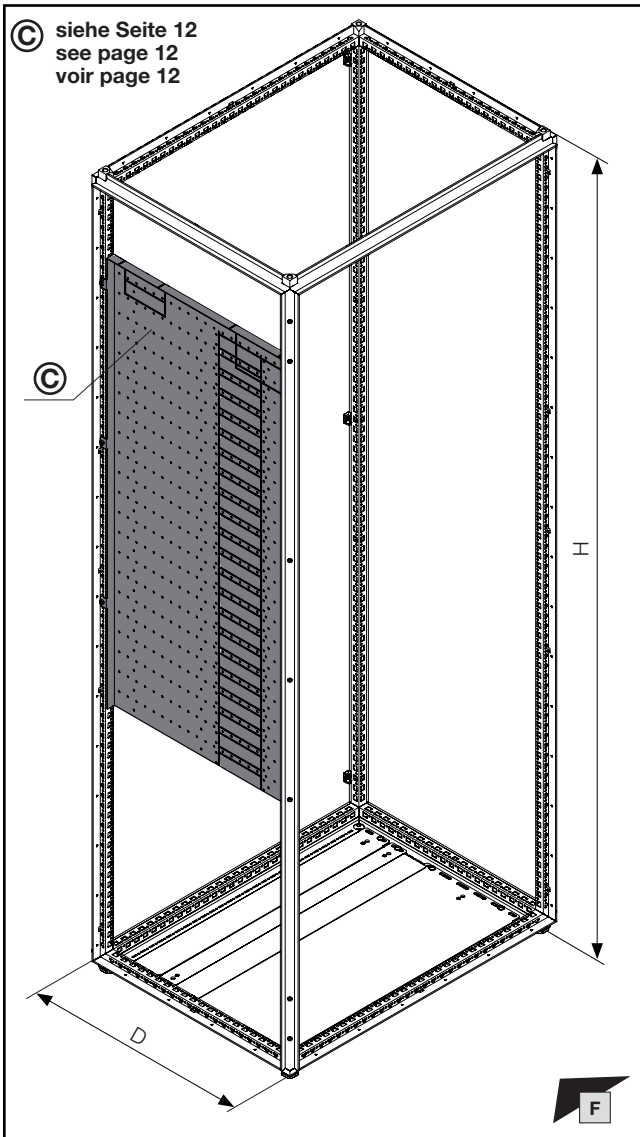

H x D mm	A mm	Best.-Nr. Model No. Référence
2000 x 600	231	9683.016
2000 x 800	231	9683.018
2200 x 600	281	9683.036
2200 x 800	281	9683.038

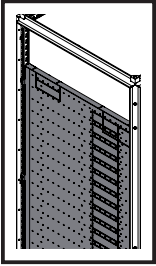

TX30



DE EN FR



1. Montage 4-poliges HSS
1. Fitting the 4-pole MBS
1. Montage des JBP tétrapolaires

- 1.5 Montage linke Funktionsraum-Seitenwand
- 1.5 Fitting the left functional space side panel
- 1.5 Montage du panneau latéral de compartiment fonctionnel à gauche

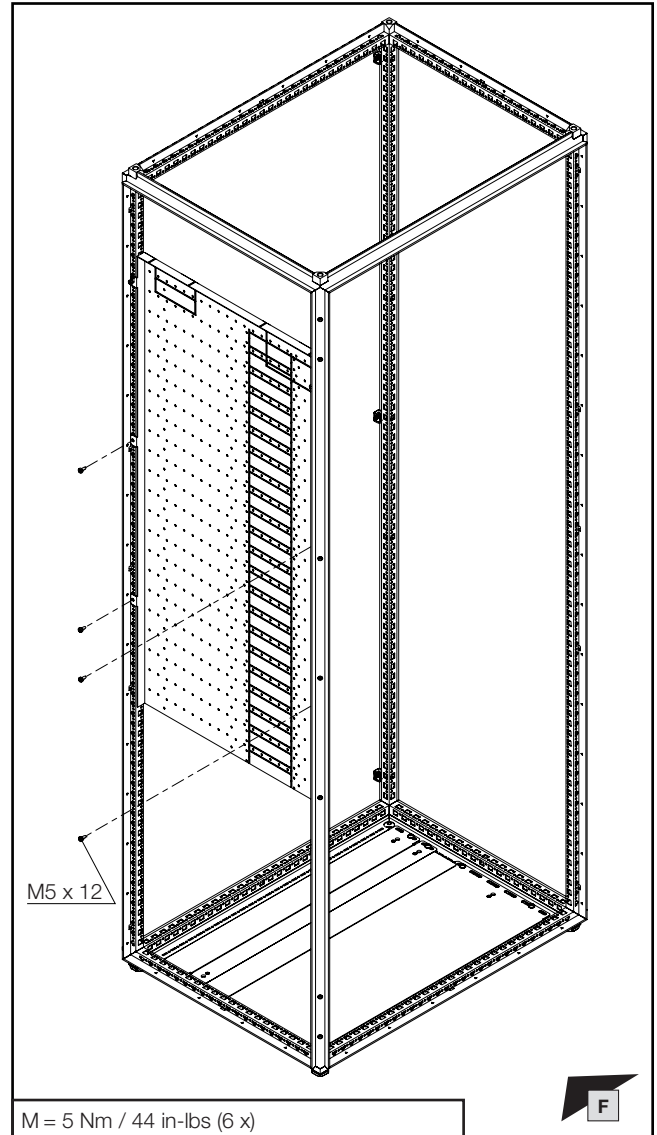
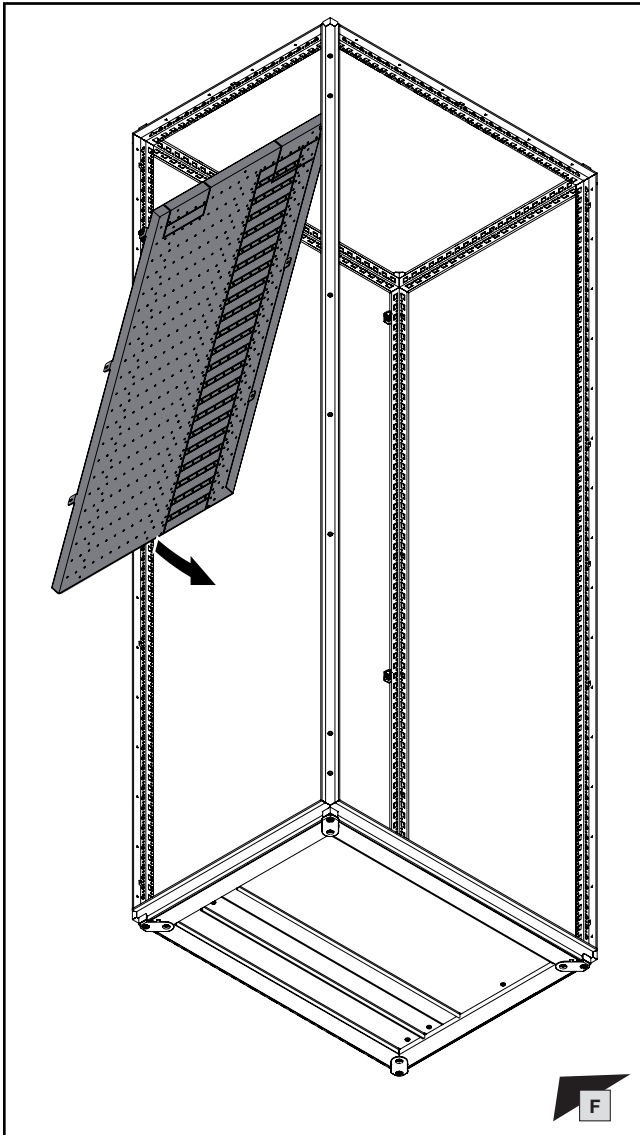

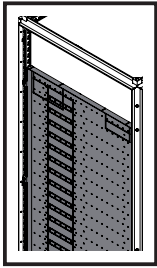

DE EN FR



1. Montage 4-poliges HSS  
 1. Fitting the 4-pole MBS  
 1. Montage des JBP tétrapolaires

- 1.6 Montage rechte Funktionsraum-Seitenwand  
 1.6 Fitting the right functional space side panel  
 1.6 Montage du panneau latéral de compartiment fonctionnel à droite

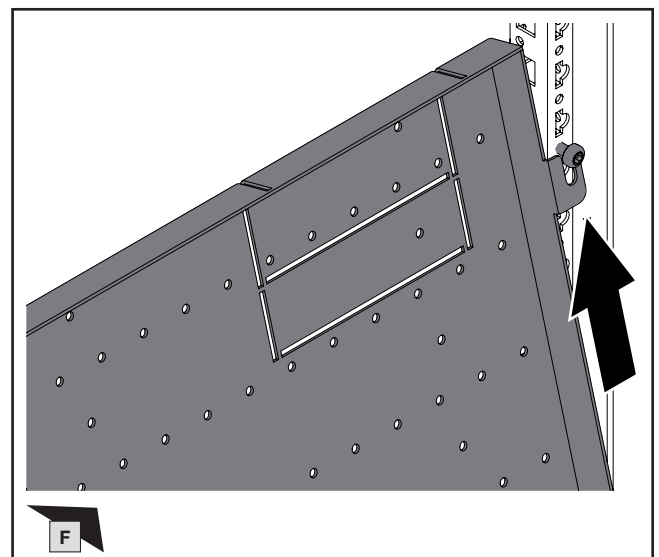
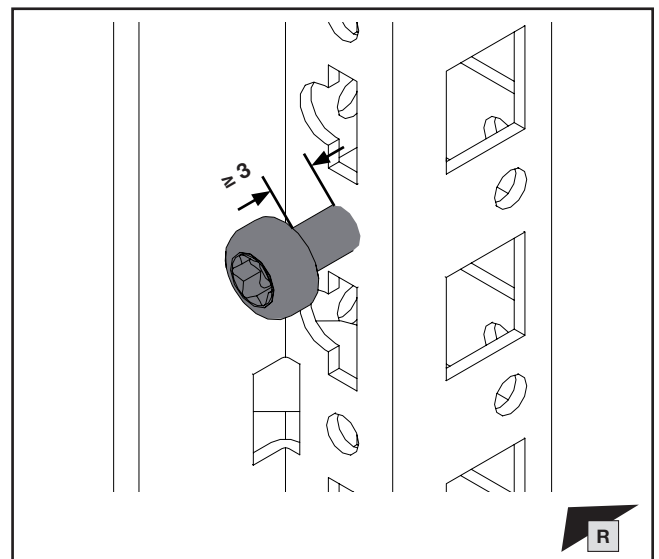
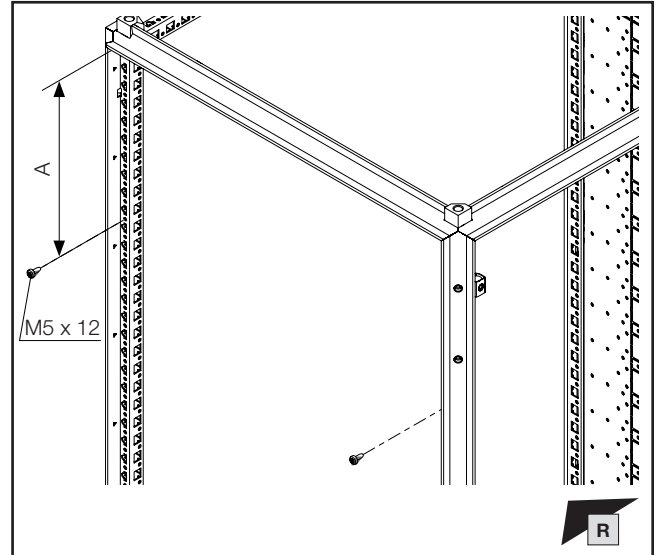
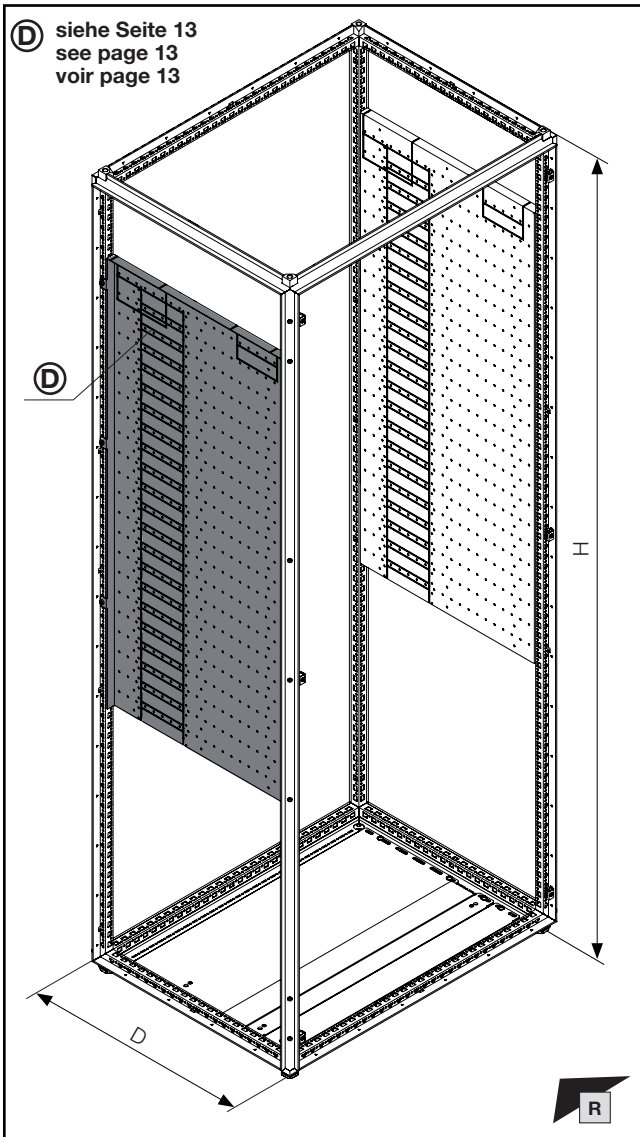

H x D mm	A mm	Best.-Nr. Model No. Référence
2000 x 600	231	9683.016
2000 x 800	231	9683.018
2200 x 600	281	9683.036
2200 x 800	281	9683.038

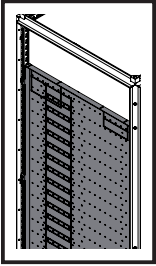

TX30



DE EN FR



1. Montage 4-poliges HSS
1. Fitting the 4-pole MBS
1. Montage des JBP tétrapolaires

- 1.6 Montage rechte Funktionsraum-Seitenwand
- 1.6 Fitting the right functional space side panel
- 1.6 Montage du panneau latéral de compartiment fonctionnel à droite

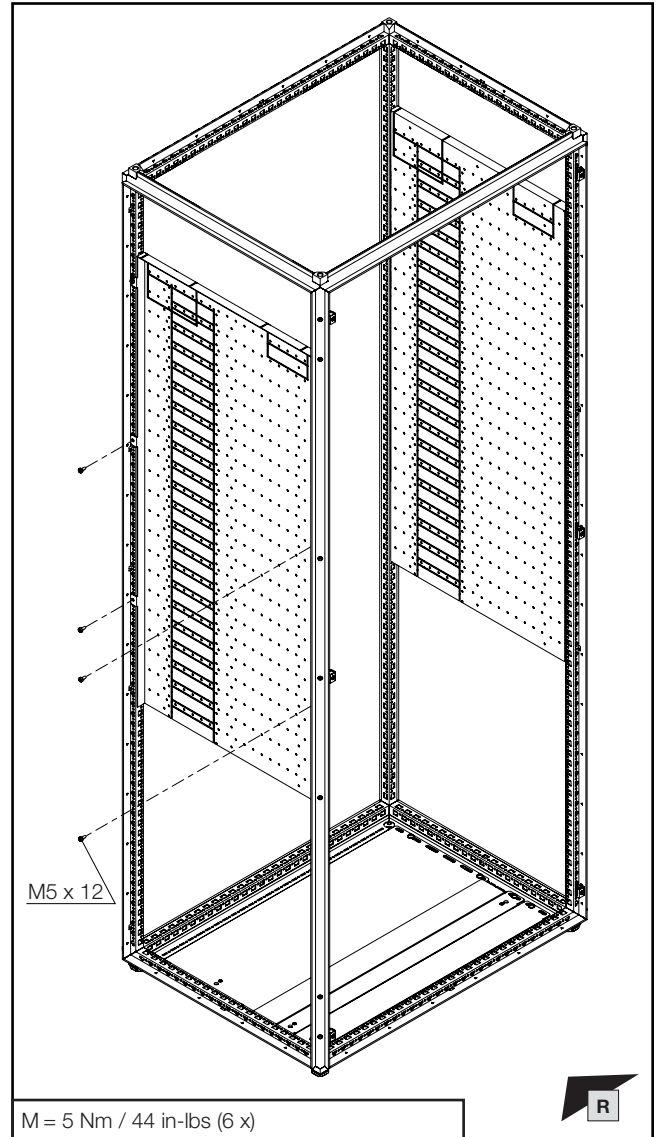
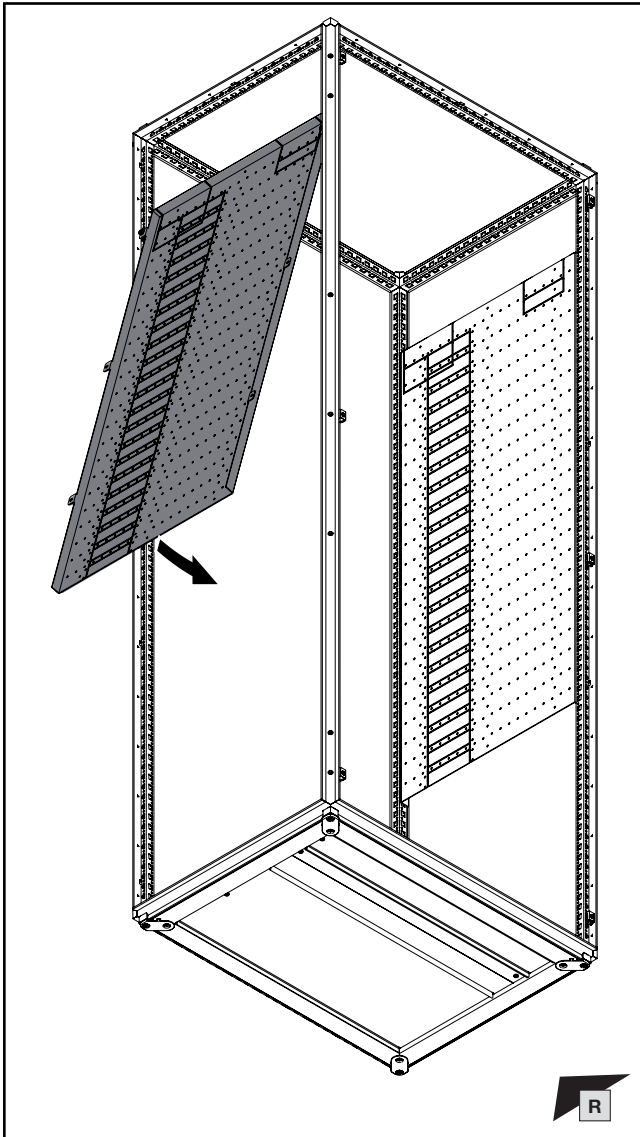

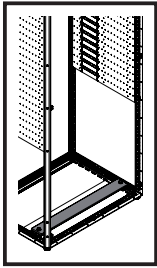

1. Montage 4-poliges HSS
1. Fitting the 4-pole MBS
1. Montage des JBP tétrapolaires

- 1.7 Montage des PE-/PEN-Sammelschienensystems
- 1.7 Fitting the PE/PEN busbar system
- 1.7 Montage des jeux de barres Terre / Terre-Neutre

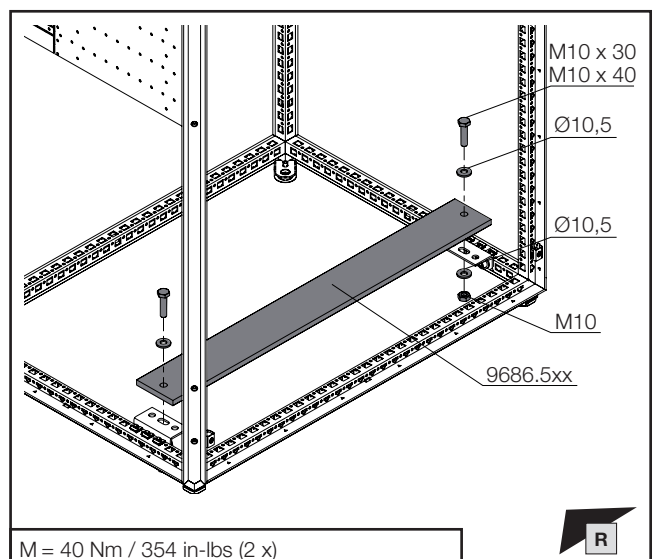
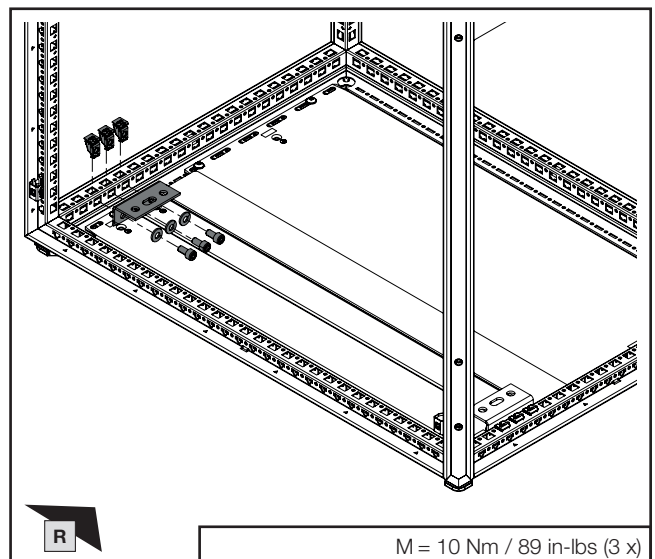
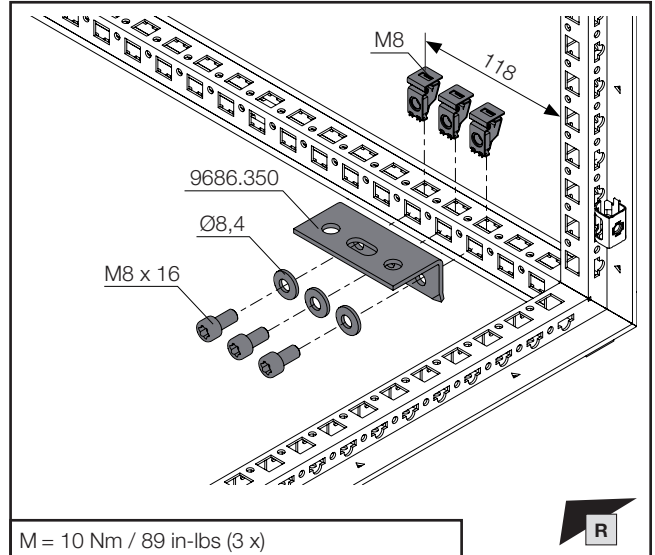
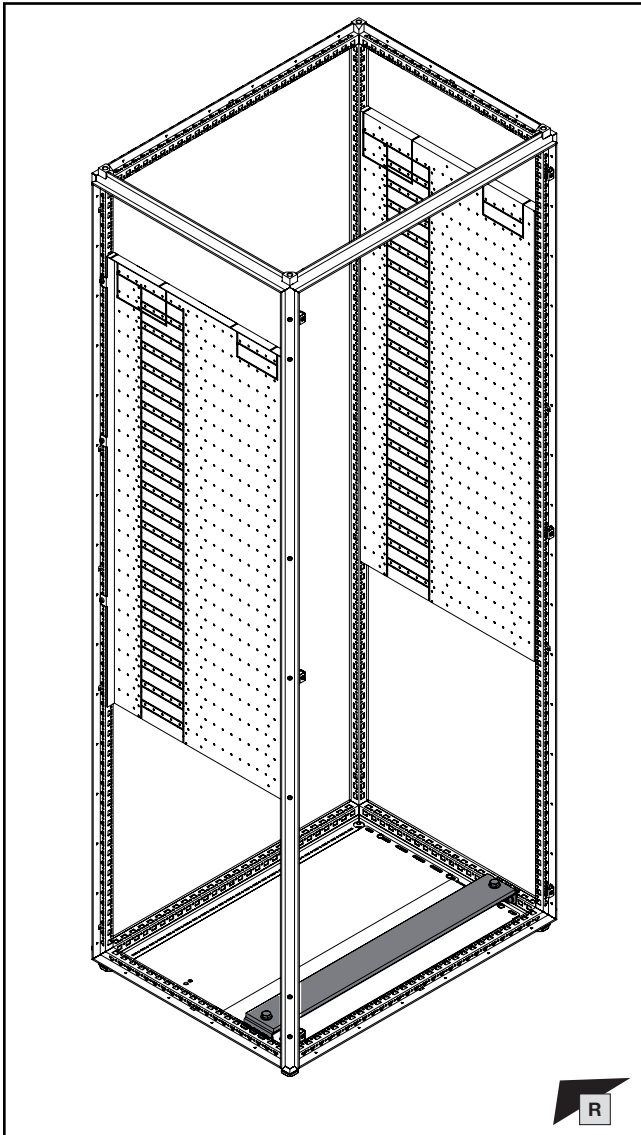

Montageanleitung VX25 Ri4Power – Schalt- und Energieverteilanlagen-System  
 Assembly instructions VX25 Ri4Power – Switchgear and power distribution system  
 Notice de montage VX25 Ri4Power – Distribution de courant  
 DE/EN/FR

Schranksystem VX25 – Technische Dokumentation – Schutzleiteranschluss, Strombelastbarkeit  
 VX25 Enclosure System – Technical documentation – PE conductor connection, current carrying capacity  
 Armoires électriques VX25 – Manuel technique – Raccordement de mise à la terre et intensités maximales admissibles  
 DE EN FR

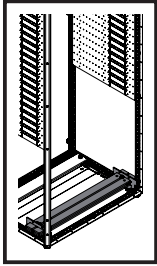

- 1. Montage 4-poliges HSS
- 1. Fitting the 4-pole MBS
- 1. Montage des JBP tétrapolaires

- 1.8 Montage des N-Sammelschienensystems
- 1.8 Fitting the N busbar system
- 1.8 Montage des jeux de barres Neutre

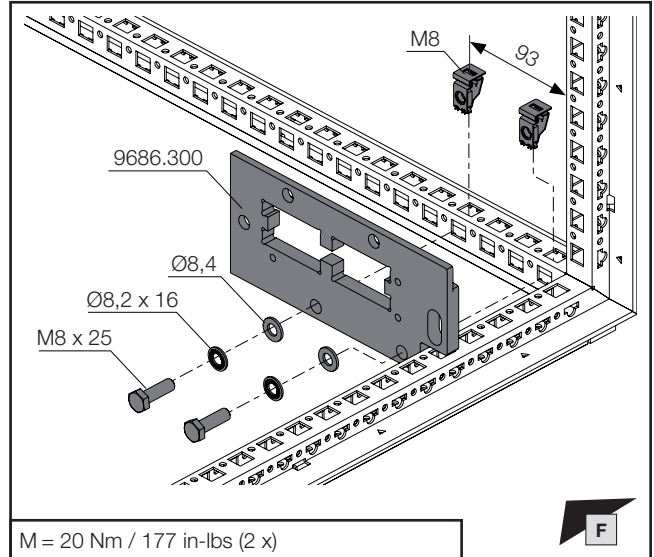
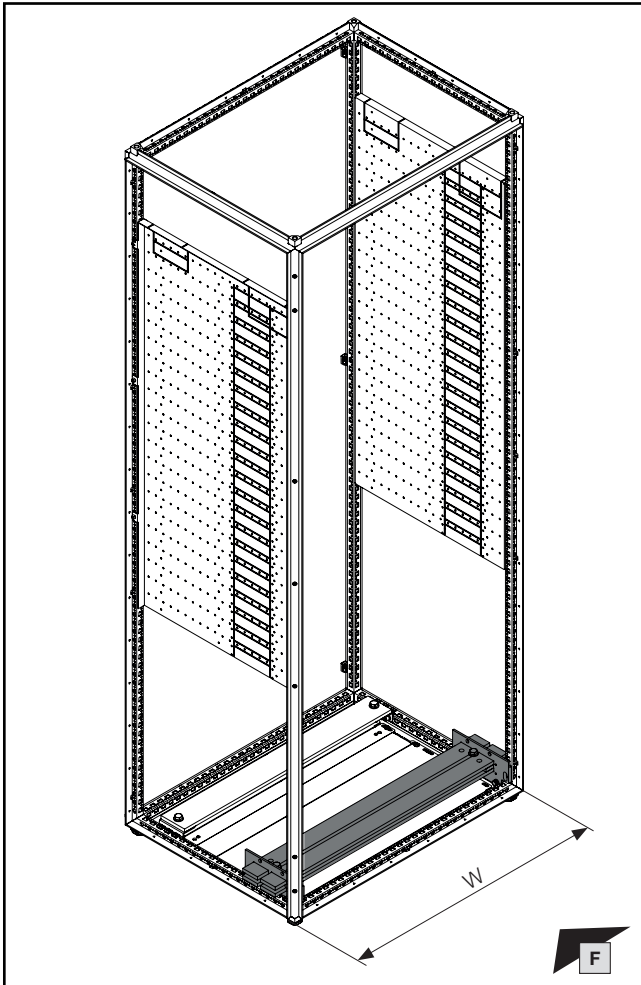

M = 20 Nm / 177 in-lbs (2 x)

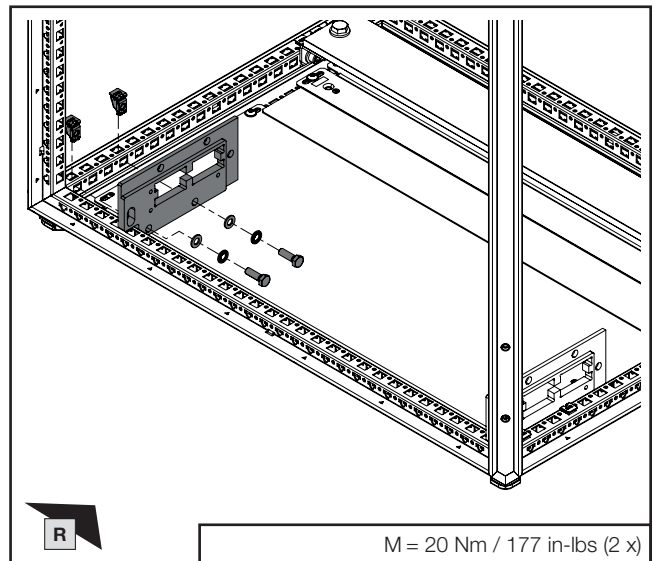

M = 20 Nm / 177 in-lbs (2 x)

Montageanleitung VX25 Ri4Power – Schalt- und Energie-  
 verteilanlagen-System  
 Assembly instructions VX25 Ri4Power – Switchgear and power  
 distribution system  
 Notice de montage VX25 Ri4Power – Distribution de courant

DE/EN/FR

W mm	(A) Best.-Nr. Model No. Référence
400	9684.004
600	9684.006
800	9684.008
100	9684.010
1200	9684.012

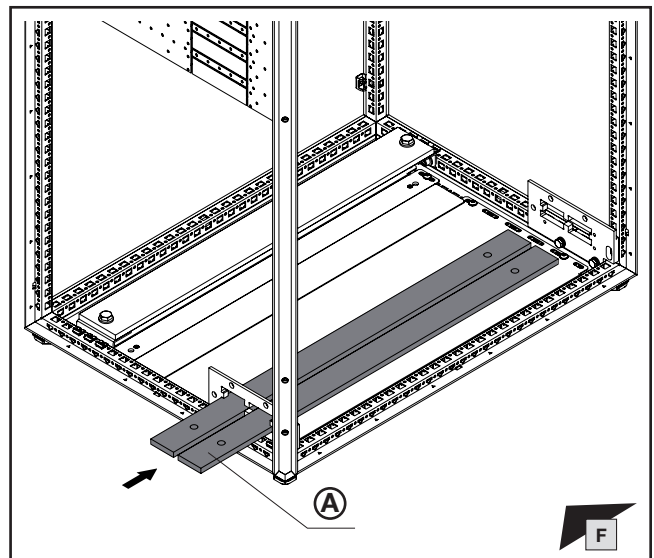

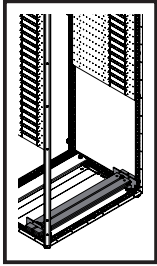

- 1. Montage 4-poliges HSS
- 1. Fitting the 4-pole MBS
- 1. Montage des JBP tétrapolaires

- 1.8 Montage des N-Sammelschienensystems
- 1.8 Fitting the N busbar system
- 1.8 Montage des jeux de barres Neutre

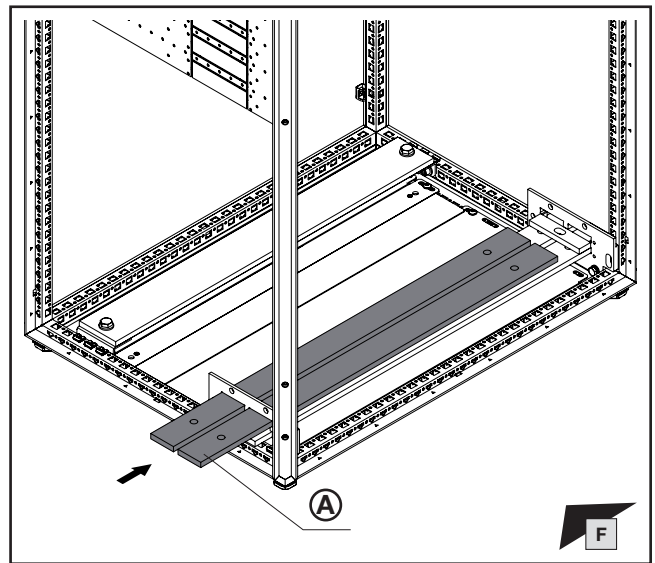
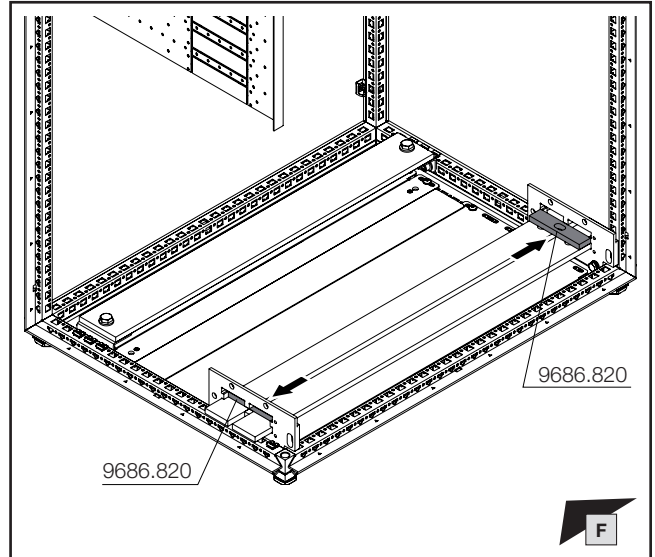
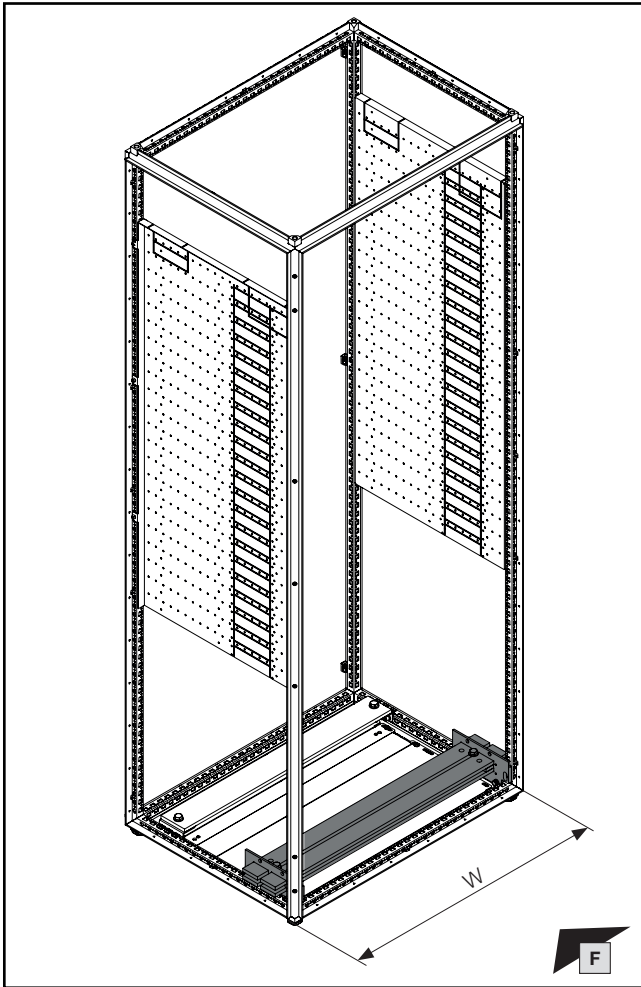

W mm	(A) Best.-Nr. Model No. Référence
400	9684.004
600	9684.006
800	9684.008
100	9684.010
1200	9684.012

Anzahl N-Sammelschienen Quantity N busbars Nombre des jeux de barres Neutre	(B) Best.-Nr. Model No. Référence
2	9686.830
4	9686.845

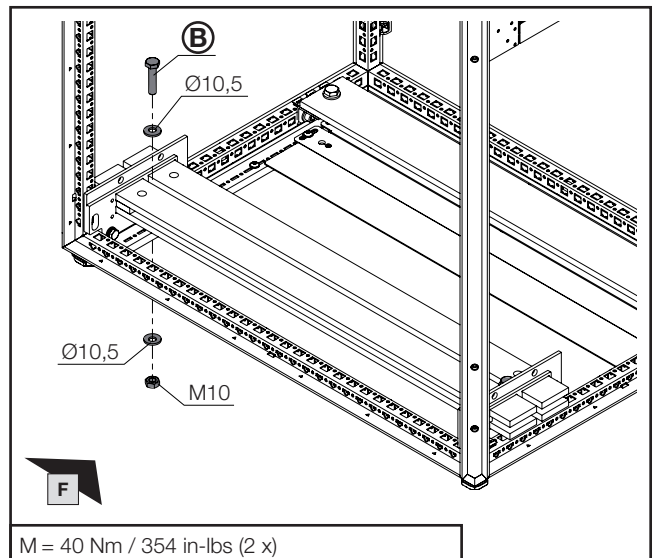

M = 40 Nm / 354 in-lbs (2 x)

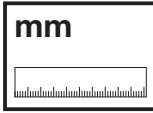
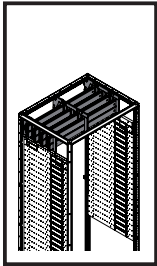

1. Montage 4-poliges HSS  
 1. Fitting the 4-pole MBS  
 1. Montage des JBP tétrapolaires

- 1.9 Montage des oberen Hauptschienensystems
- 1.9 Fitting the upper main busbar system
- 1.9 Montage des jeux de barres principaux supérieurs

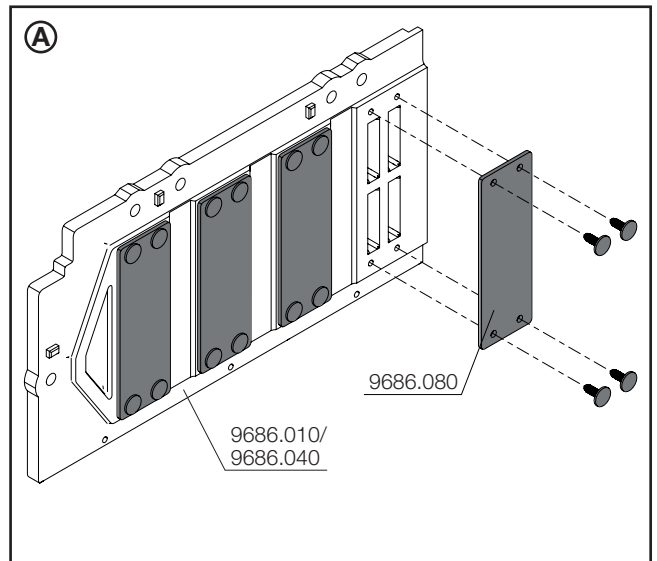
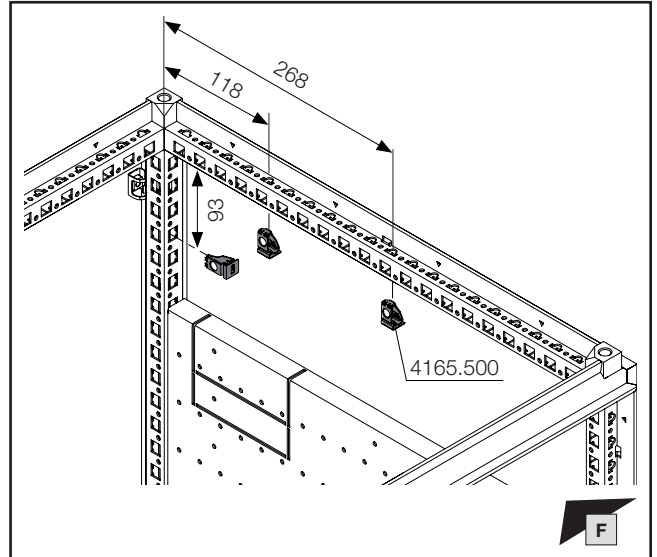
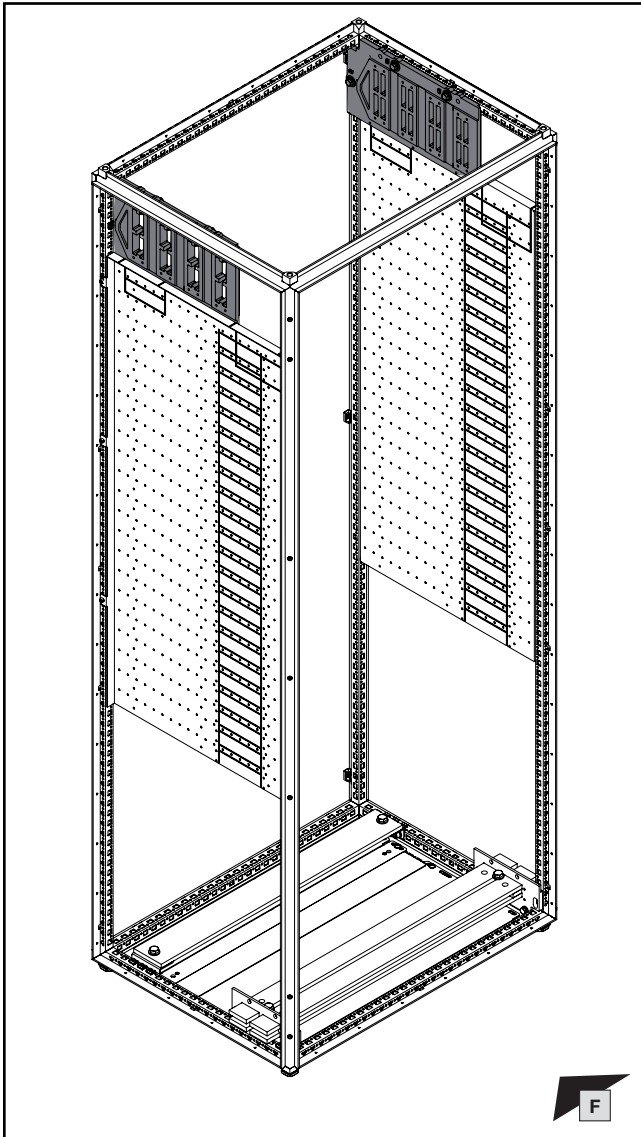

Montageanleitung VX25 Ri4Power – Schalt- und Energieverteilanlagen-System  
 Assembly instructions VX25 Ri4Power – Switchgear and power distribution system  
 Notice de montage VX25 Ri4Power – Distribution de courant

 DE/EN/FR



Hinweis / Note / Remarque

Für Schutz Eigenschaft Störlichtbogenklasse B Montagerihenfolge in den entsprechenden Abschnitten der o. g. Anleitung beachten.

For arcing class B protection, please follow the assembly sequence as set out in the relevant chapters of the aforementioned assembly instructions.

Pour la protection contre les arcs électriques de catégorie B, suivez la séquence de montage indiquée dans les sections correspondantes des instructions ci-dessus.

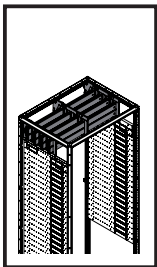

- 1. Montage 4-poliges HSS
- 1. Fitting the 4-pole MBS
- 1. Montage des JBP tétrapolaires

- 1.9 Montage des oberen Hauptschienensystems
- 1.9 Fitting the upper main busbar system
- 1.9 Montage des jeux de barres principaux supérieurs

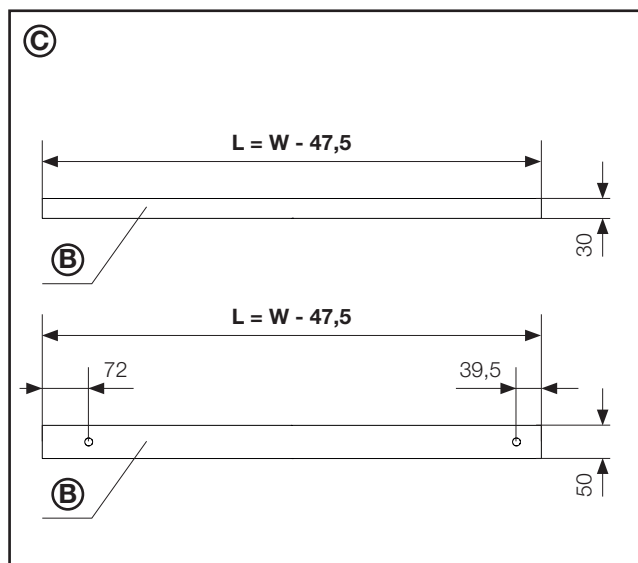
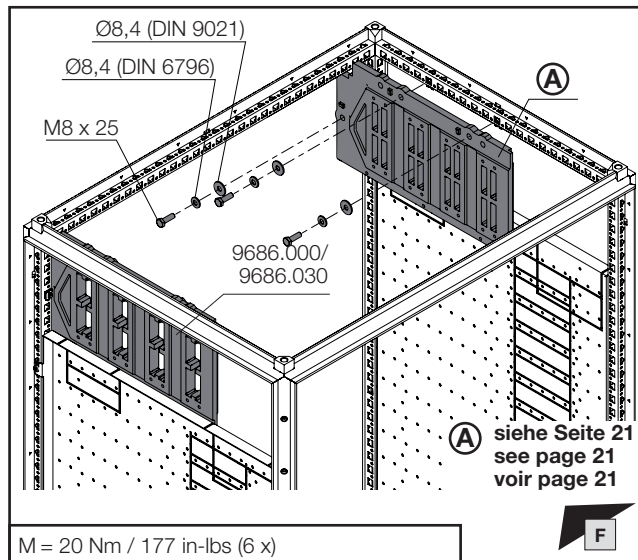
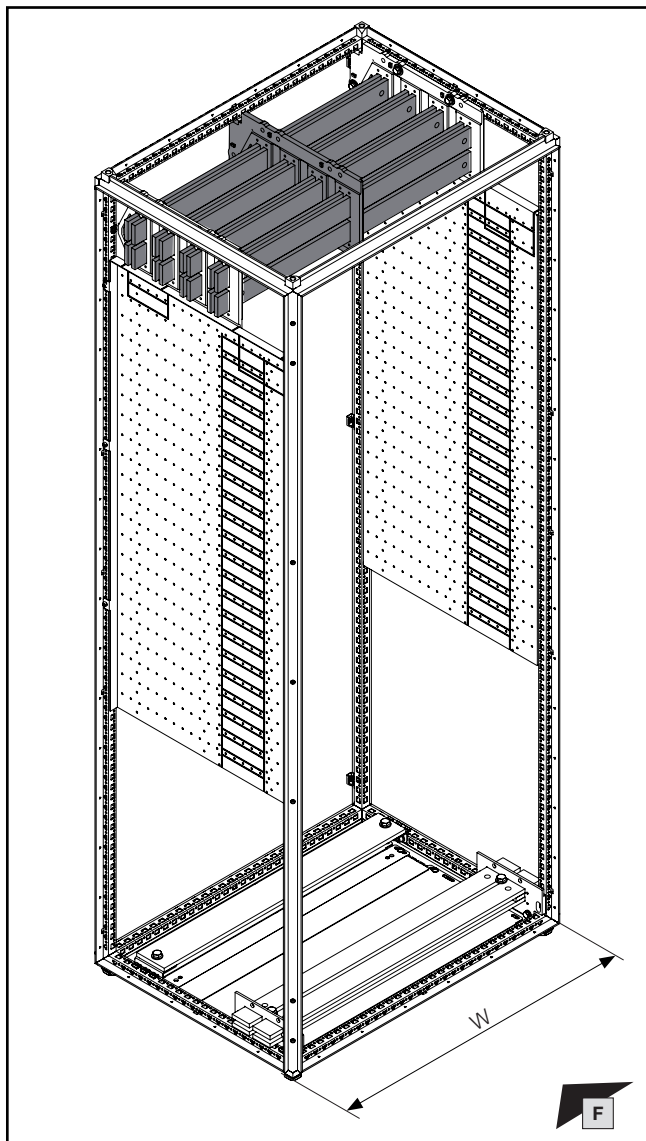

W mm	Sammelschiene Abmessung mm Busbar dimensions mm Dimensions de la barre mm	Best.-Nr. Model No. Référence
400	50 x 10	9684.004
600	50 x 10	9684.006
800	50 x 10	9684.008
100	50 x 10	9684.010
1200	50 x 10	9684.012
-	30 x 10	3586.005

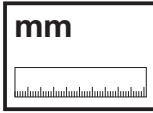
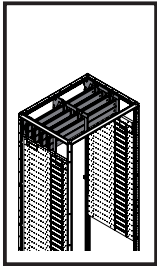

1. Montage 4-poliges HSS  
 1. Fitting the 4-pole MBS  
 1. Montage des JBP tétrapolaires

- 1.9 Montage des oberen Hauptschienensystems
- 1.9 Fitting the upper main busbar system
- 1.9 Montage des jeux de barres principaux supérieurs

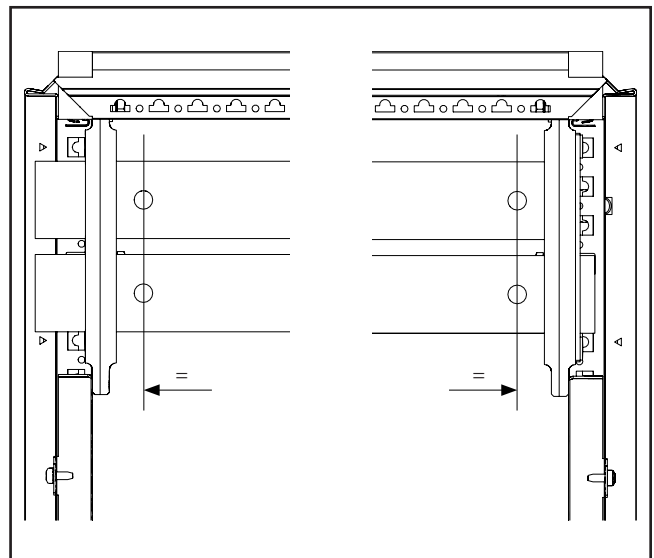
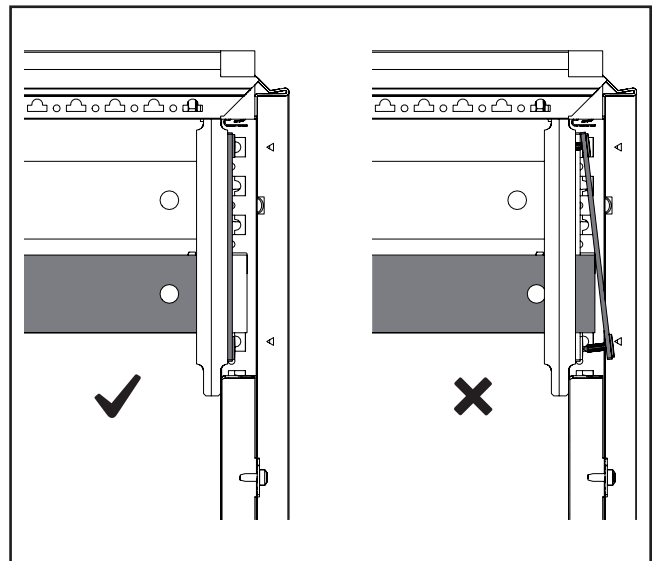
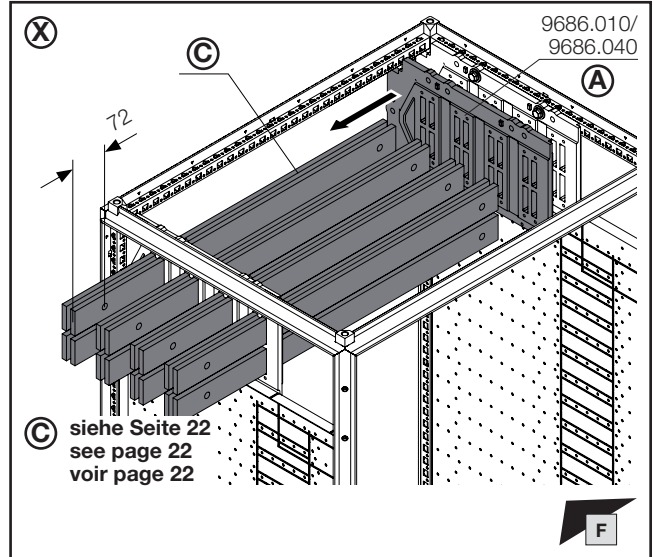
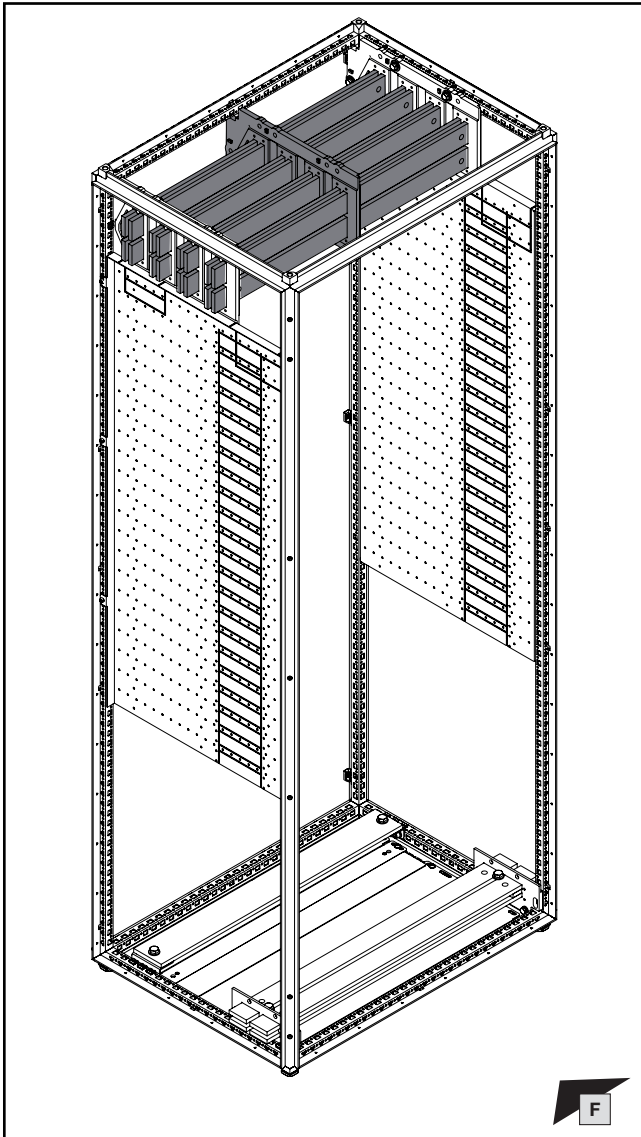

**Hinweis / Note / Remarque (X)**  
 Der „schwimmende“ Sammelschienenhalter (A) wird abhängig von der Stromkurzschlussfestigkeit benötigt. Die Berechnung findet in der Online-Berechnungssoftware „RiPower“ im Niederspannungsschaltanlagen Konfigurator statt.  
 The "floating" busbar support (A) may be required depending on the short-circuit resistance, which is calculated by the online calculation software "RiPower" in the low-voltage switchgear configurator.  
 Le support de jeux de barres « flottant » (A) est requis en fonction de la résistance aux courants de courts-circuits. Le calcul est réalisé via le logiciel de calcul en ligne « VX25 Rittal Power Engineering ».

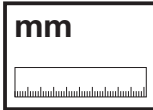
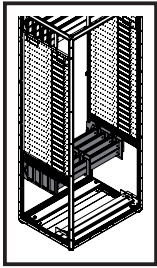

DE EN FR



1. Montage 4-poliges HSS
1. Fitting the 4-pole MBS
1. Montage des JBP tétrapolaires

- 1.10 Montage des unteren Hauptschienensystems
- 1.10 Fitting the lower main busbar system
- 1.10 Montage des jeux de barres principaux inférieurs

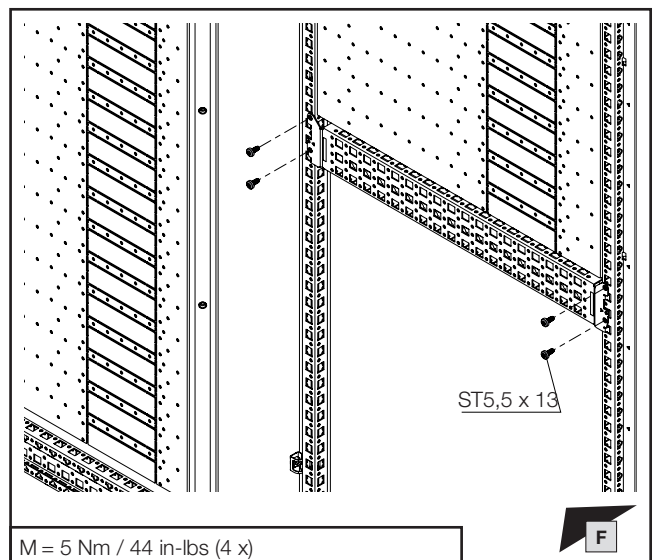
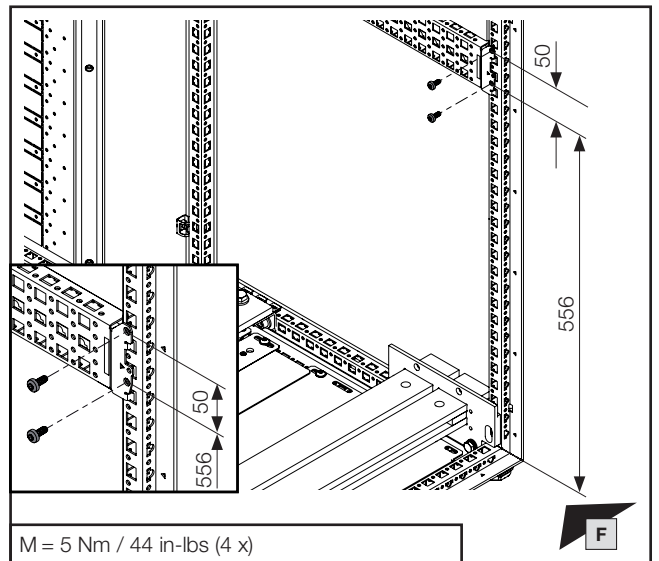
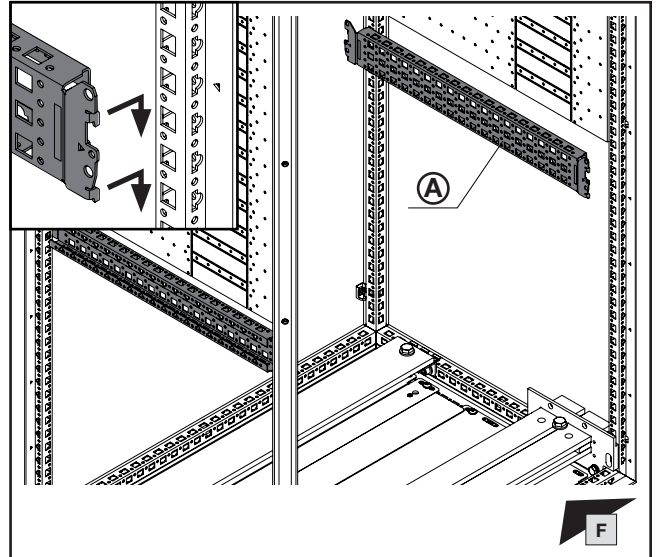
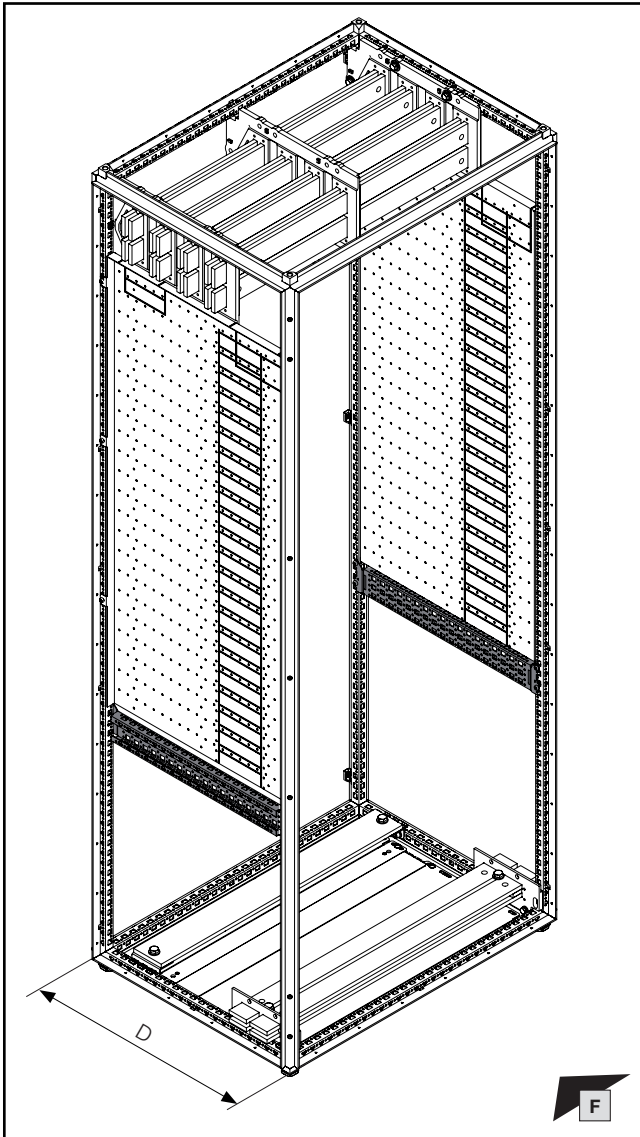

D mm	(A) Best.-Nr. Model No. Référence
600	8617.130
800	8617.140

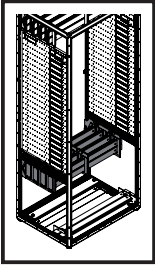

- 1. Montage 4-poliges HSS
- 1. Fitting the 4-pole MBS
- 1. Montage des JBP tétrapolaires

- 1.10 Montage des unteren Hauptschienensystems
- 1.10 Fitting the lower main busbar system
- 1.10 Montage des jeux de barres principaux inférieurs

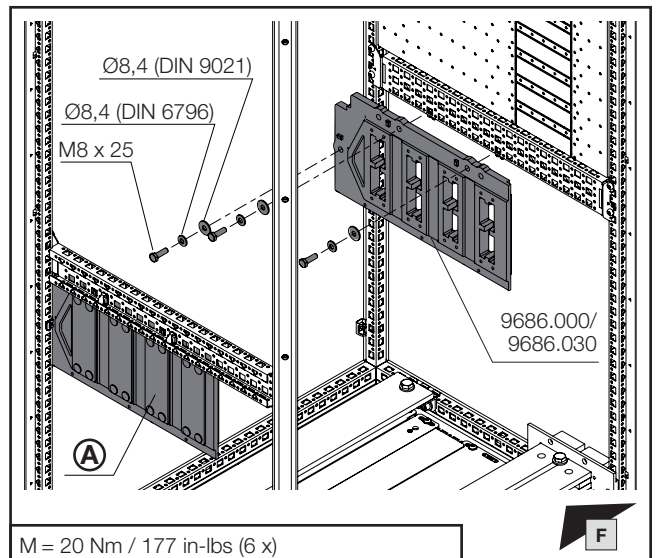
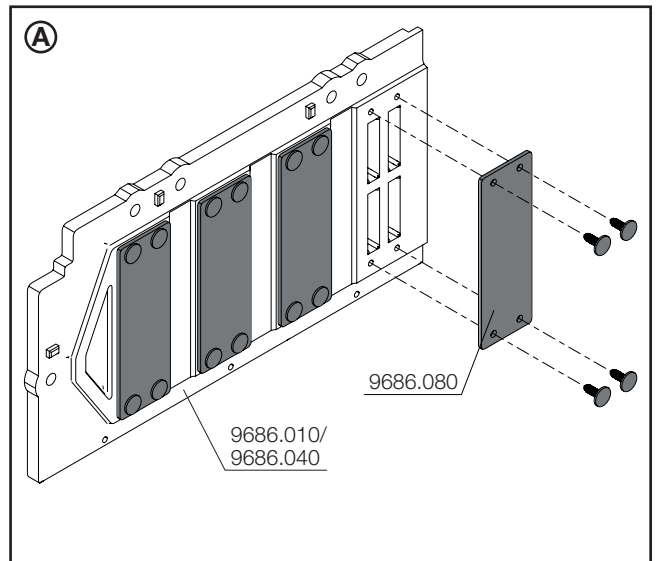
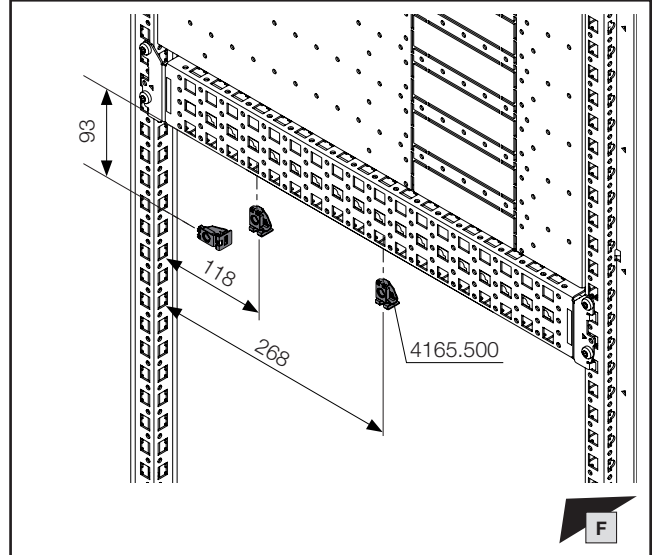
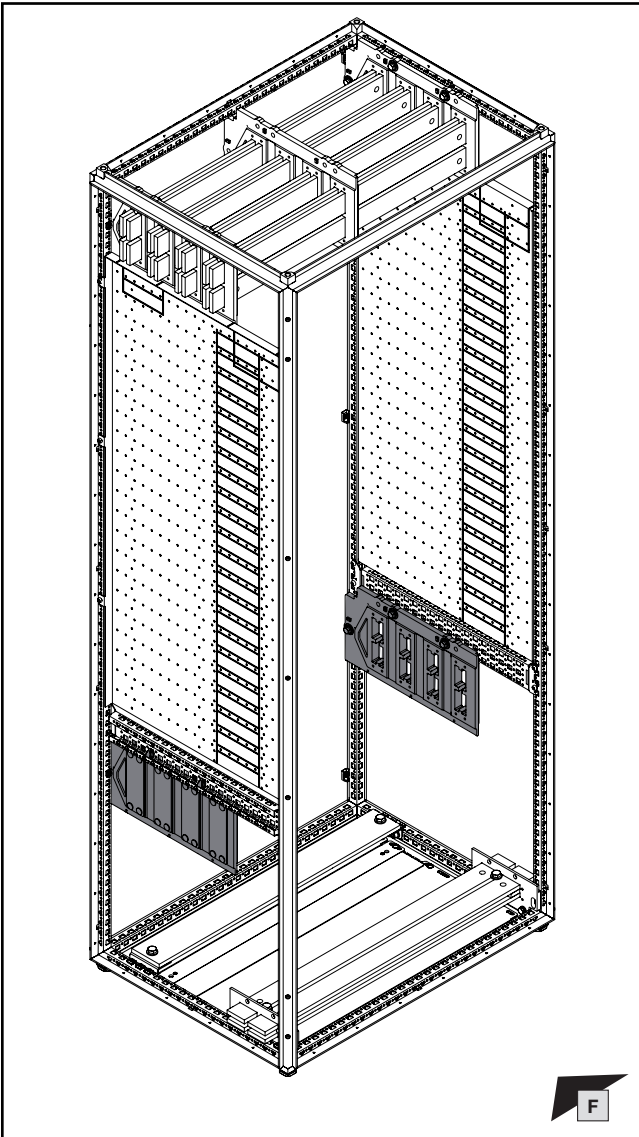

M = 20 Nm / 177 in-lbs (6 x)

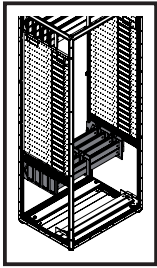

1. Montage 4-poliges HSS
1. Fitting the 4-pole MBS
1. Montage des JBP tétrapolaires

- 1.10 Montage des unteren Hauptschienensystems
- 1.10 Fitting the lower main busbar system
- 1.10 Montage des jeux de barres principaux inférieurs

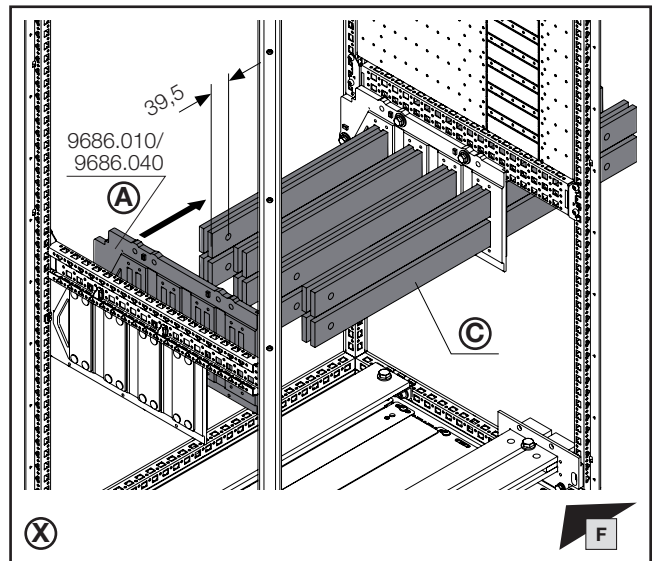
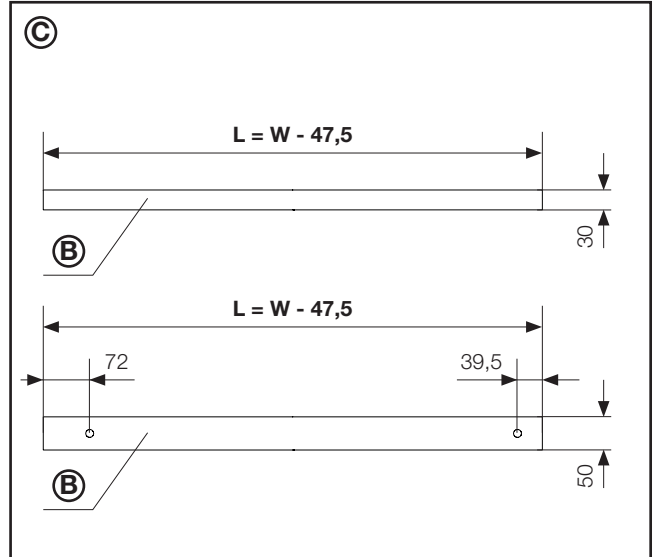
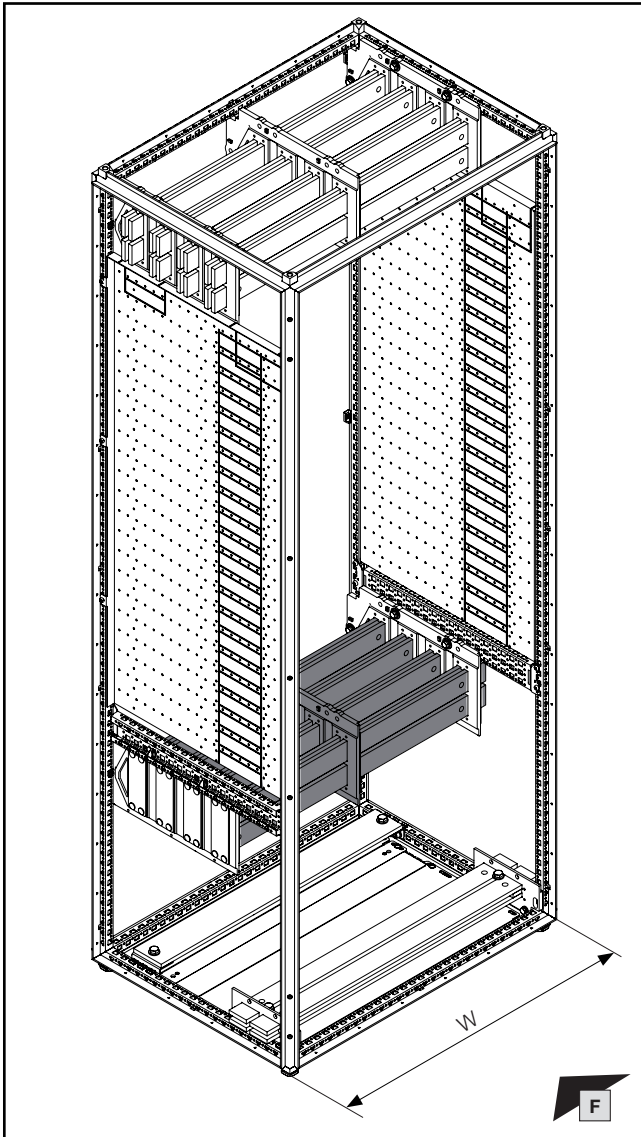

W mm	Sammelschiene Abmessung mm Busbar dimensions mm Dimensions de la barre mm	(B) Best.-Nr. Model No. Référence
400	50 x 10	9684.004
600	50 x 10	9684.006
800	50 x 10	9684.008
100	50 x 10	9684.010
1200	50 x 10	9684.012
-	30 x 10	3586.005



Hinweis / Note / Remarque (X)



Der „schwimmende“ Sammelschienehalter (A) wird abhängig von der Stromkurzschlussfestigkeit benötigt. Die Berechnung findet in der Online-Berechnungssoftware „RiPower“ im Niederspannungsschaltanlagen Konfigurator statt.

The "floating" busbar support (A) may be required depending on the short-circuit resistance, which is calculated by the online calculation software "RiPower" in the low-voltage switchgear configurator.

Le support de jeux de barres « flottant » (A) est requis en fonction de la résistance aux courants de courts-circuits. Le calcul est réalisé via le logiciel de calcul en ligne « VX25 Rittal Power Engineering ».



RiPower

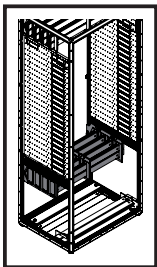

- 1. Montage 4-poliges HSS
- 1. Fitting the 4-pole MBS
- 1. Montage des JBP tétrapolaires

- 1.10 Montage des unteren Hauptschienensystems
- 1.10 Fitting the lower main busbar system
- 1.10 Montage des jeux de barres principaux inférieurs

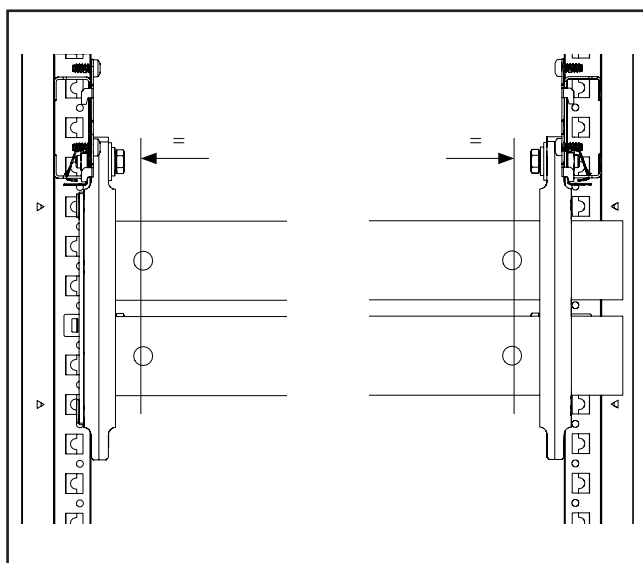
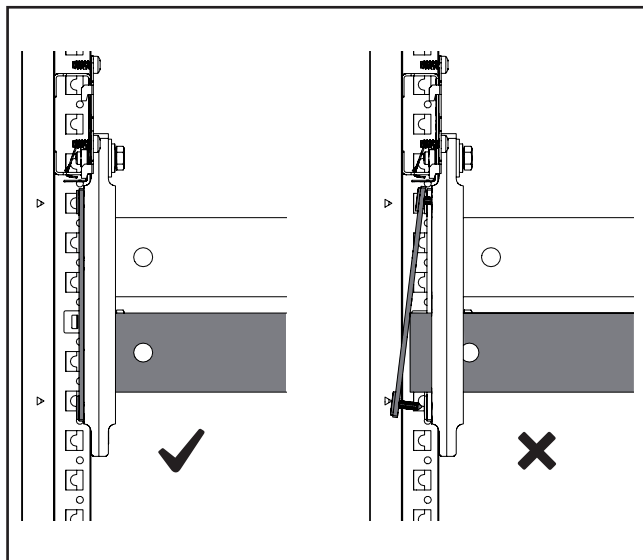
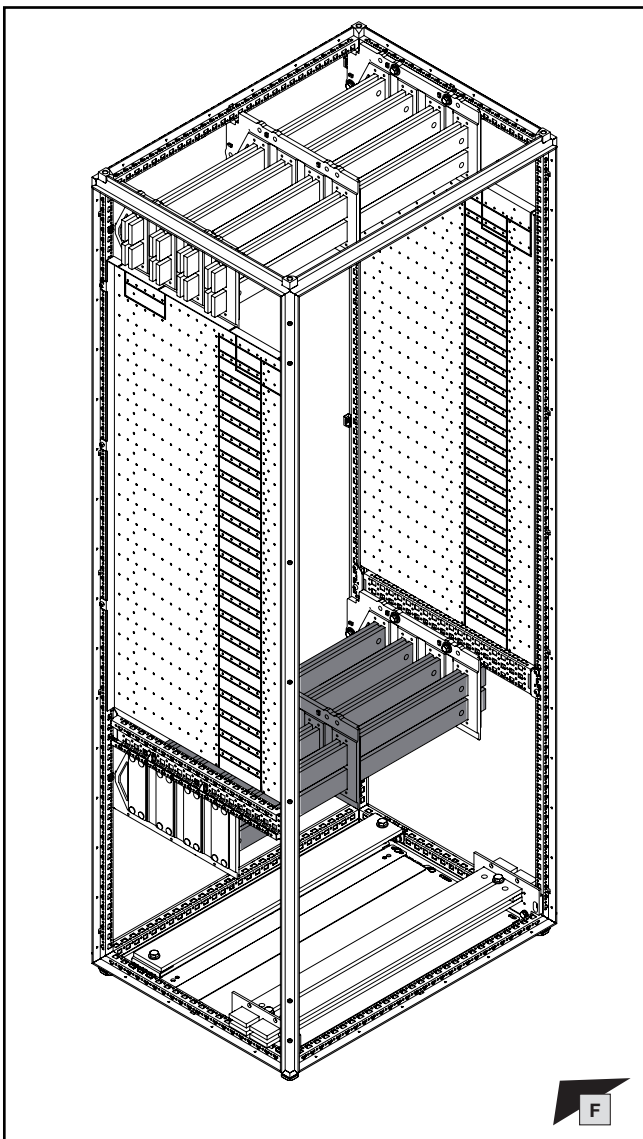

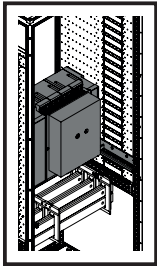

1. Montage 4-poliges HSS
1. Fitting the 4-pole MBS
1. Montage des JBP tétrapolaires

- 1.11 Montage des offenen Leistungsschalters
- 1.11 Fitting the circuit-breaker
- 1.11 Montage du disjoncteur de puissance

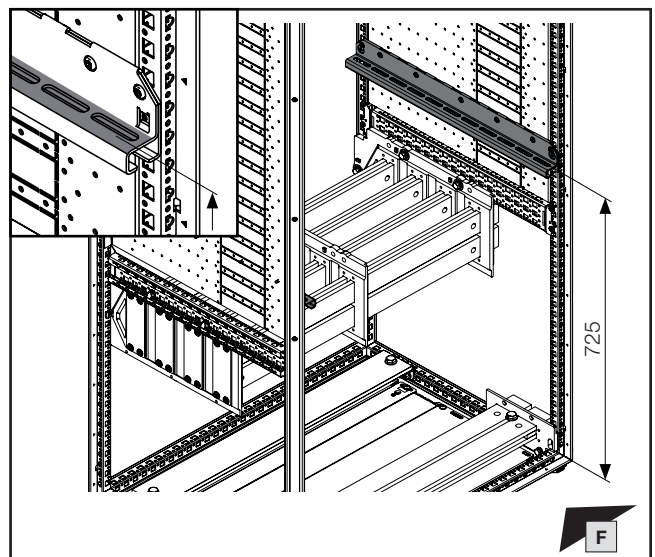
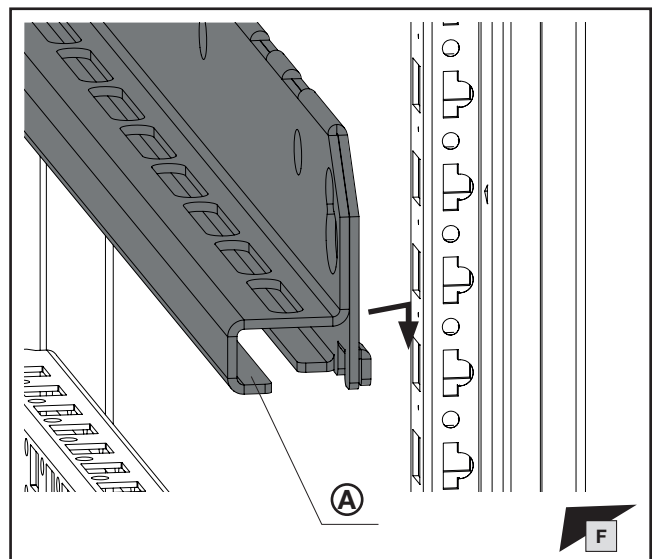
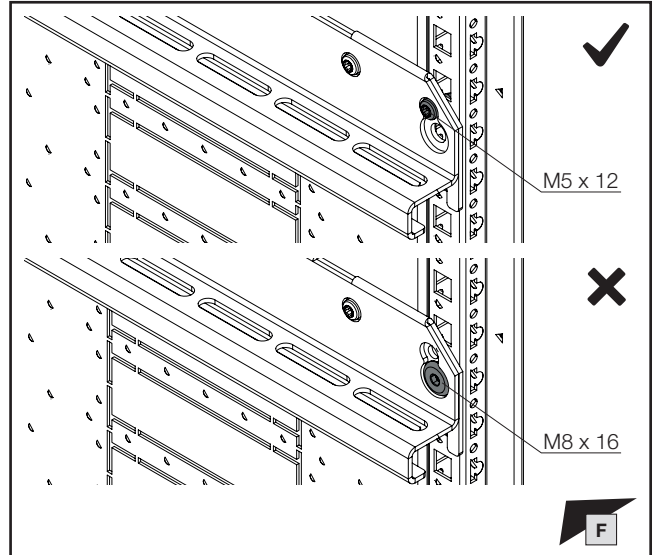
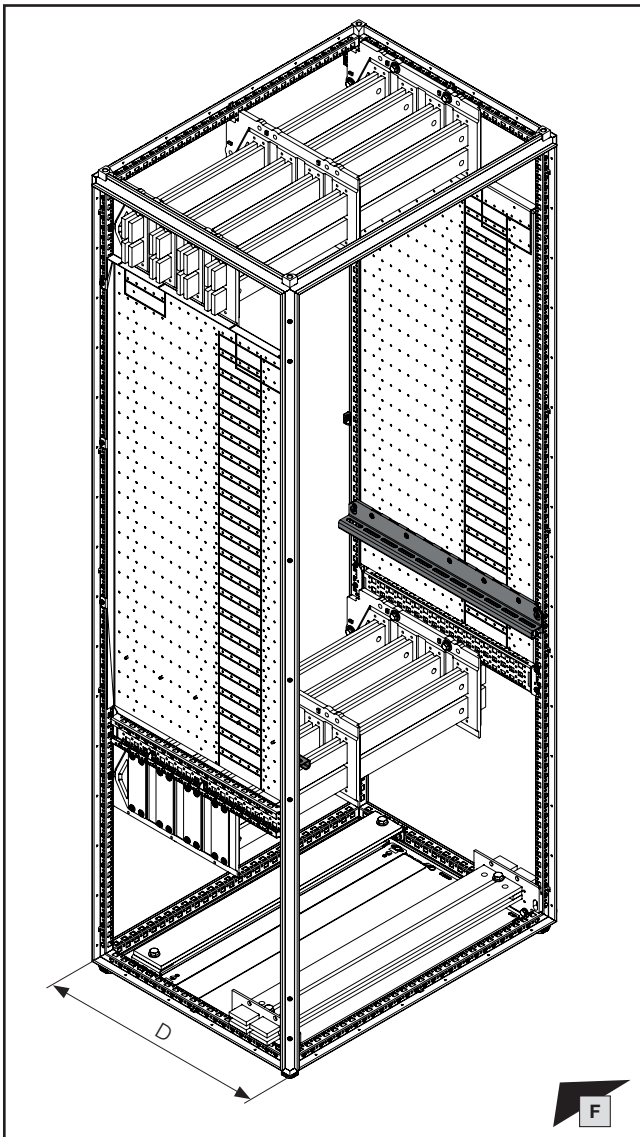

**Hinweis / Note / Remarque**  
**Vorbereitende Arbeiten für Leistungsschalter > 3000 N: siehe Kapitel 1.3.**  
**Preparatory tasks for air circuit-breakers > 3,000 N: see chapter 1.3.**  
**Travaux préparatoires pour disjoncteurs de puissance > 3000 N : voir chapitre 1.3.**

D mm	Best.-Nr. Model No. Référence
600	9683.326
800	9683.328

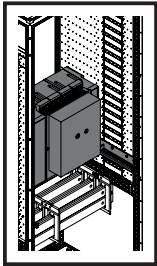

1. Montage 4-poliges HSS
1. Fitting the 4-pole MBS
1. Montage des JBP tétrapolaires

- 1.11 Montage des offenen Leistungsschalters
- 1.11 Fitting the circuit-breaker
- 1.11 Montage du disjoncteur de puissance

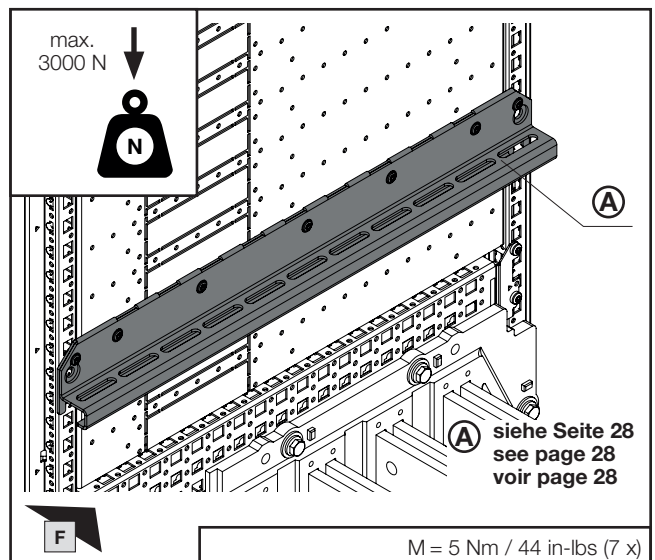
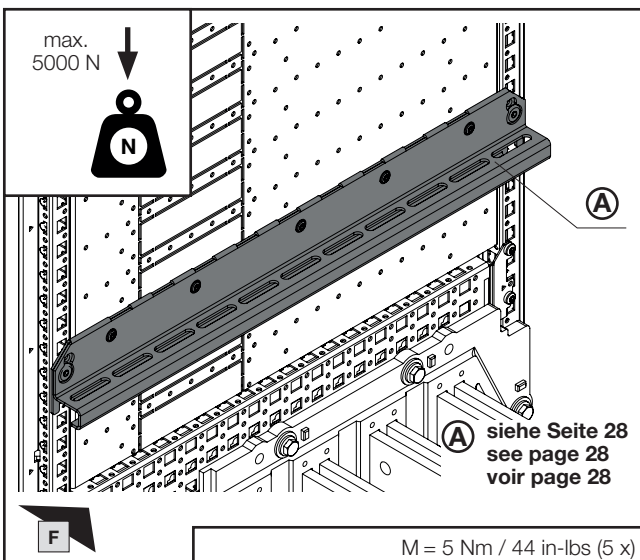
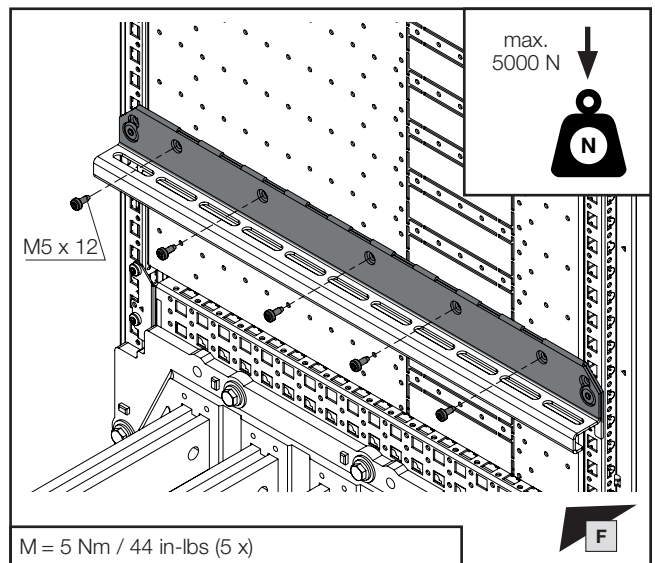
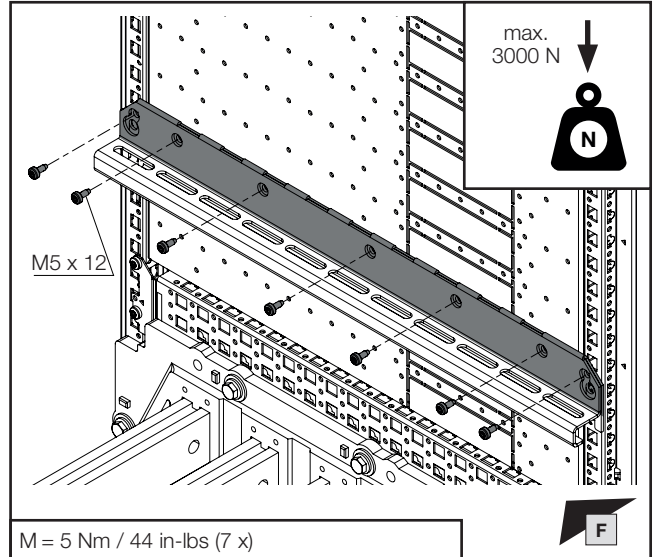
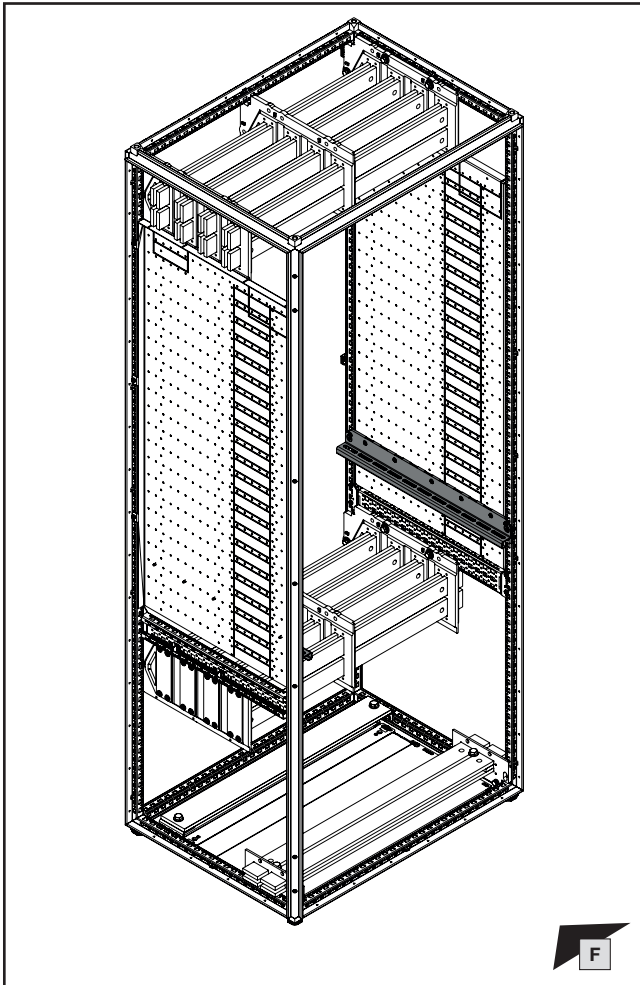

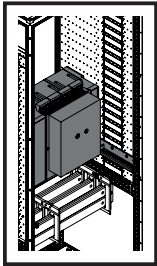

**TX30**



**1. Montage 4-poliges HSS**  
**1. Fitting the 4-pole MBS**  
**1. Montage des JBP tétrapolaires**

- 1.11 Montage des offenen Leistungsschalters
- 1.11 Fitting the circuit-breaker
- 1.11 Montage du disjoncteur de puissance

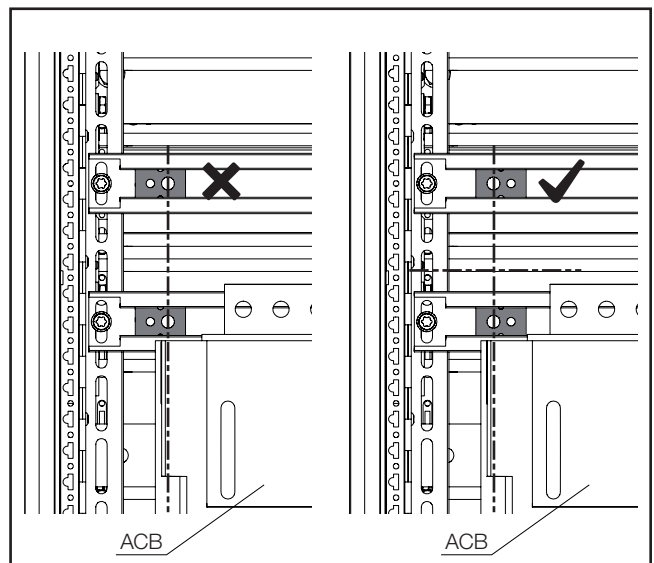
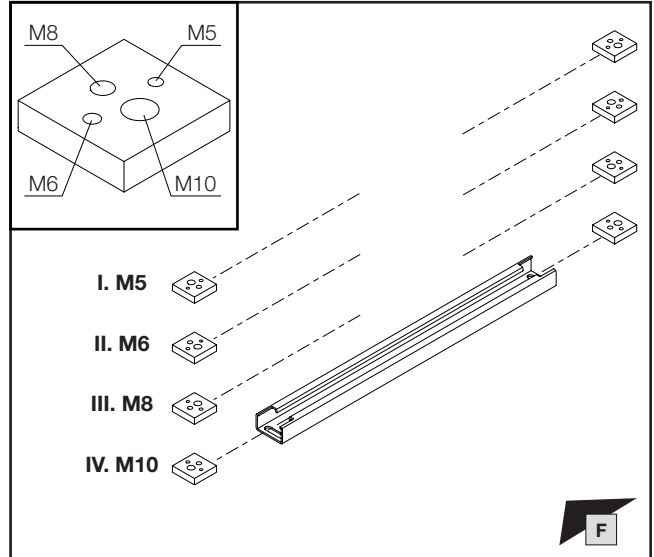
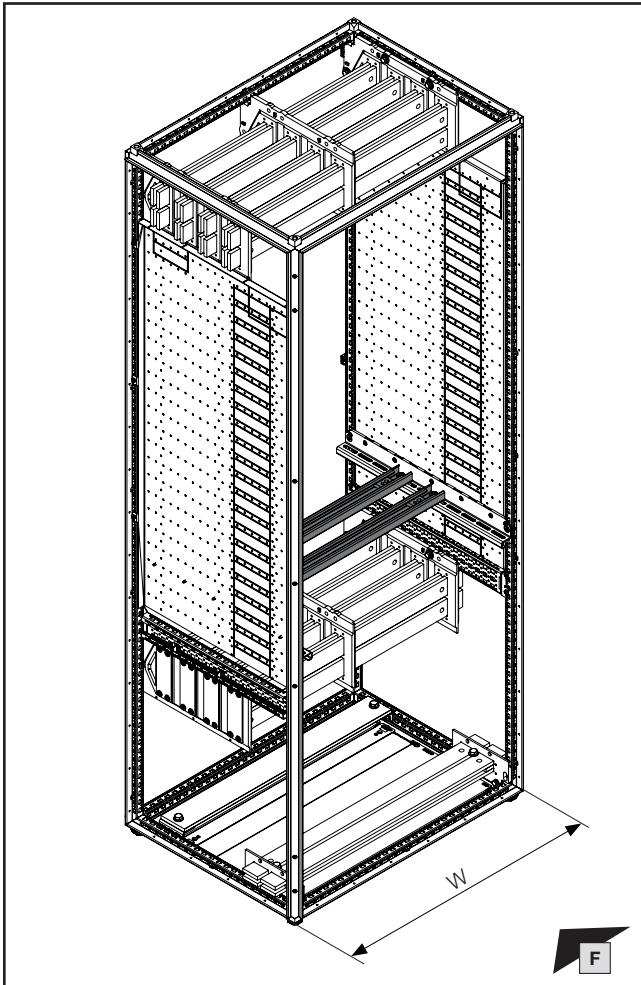

W mm	Best.-Nr. Model No. Référence
400	9683.304
600	9683.306
800	9683.308
1000	9683.310
1200	9683.312



**Hinweis / Note / Remarque I./II.**  
**Auswahl Befestigungsschrauben gemäß Hersteller des ACB!**  
**Selection of fastening screws in accordance with the manufacturer of the ACB!**  
**Choix des vis de fixation en fonction de la marque du disjoncteur de puissance !**

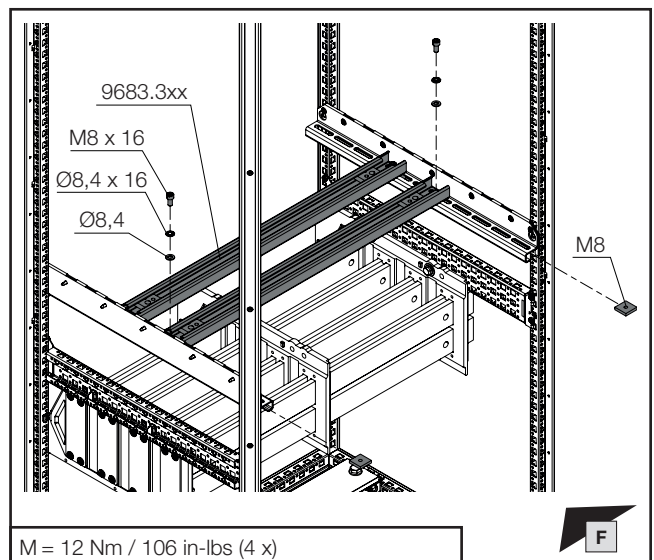

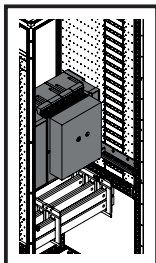

- 1. Montage 4-poliges HSS
- 1. Fitting the 4-pole MBS
- 1. Montage des JBP tétrapolaires

- 1.11 Montage des offenen Leistungsschalters
- 1.11 Fitting the circuit-breaker
- 1.11 Montage du disjoncteur de puissance

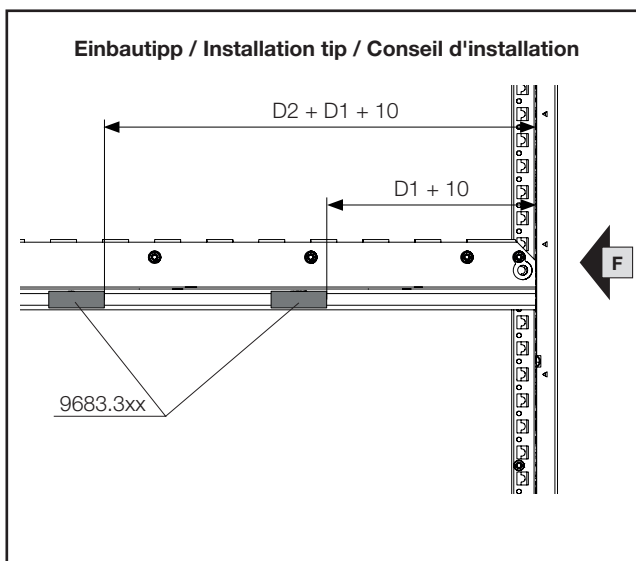
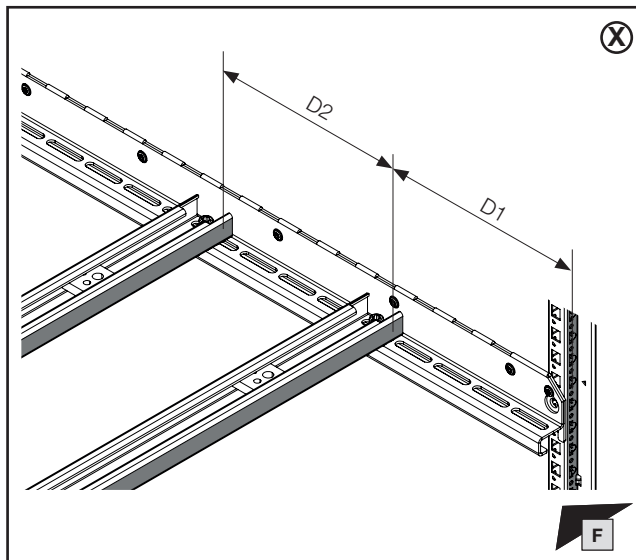
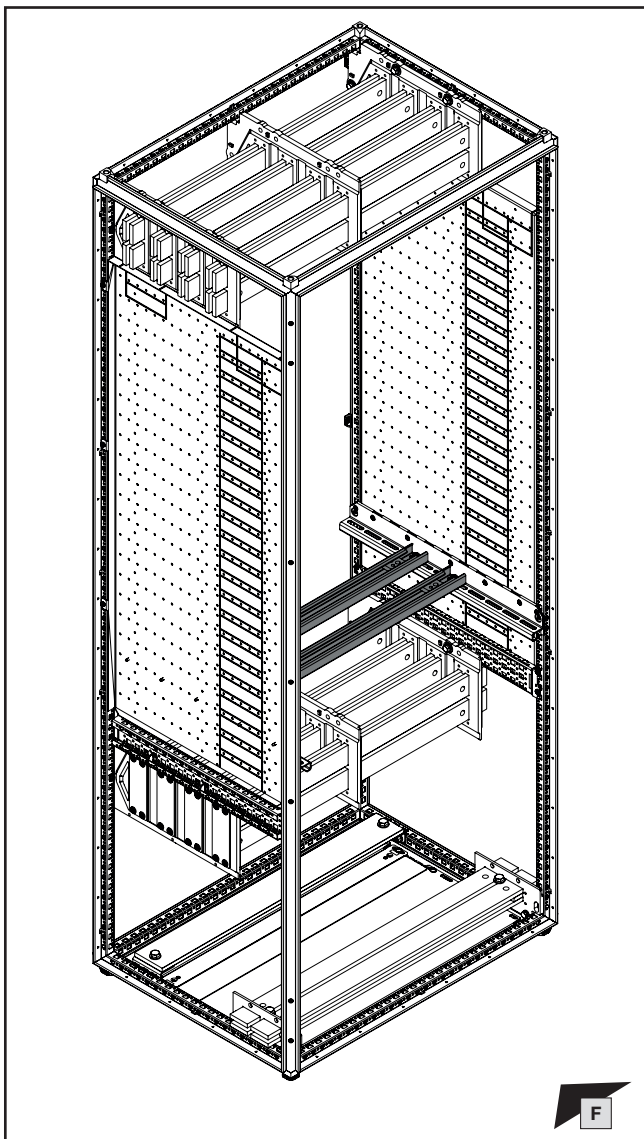

Hinweis / Note / Remarque (X)

Die Maße „D1“ und „D2“ werden mit Hilfe der Online-Berechnungssoftware „RiPower“ im Niederspannungsschaltanlagen Konfigurator ermittelt.

The dimensions "D1" and "D2" are calculated using the online calculation software "RiPower" in the low-voltage switchgear configurator.

Les dimensions « D1 » et « D2 » sont déterminées à l'aide du logiciel de calcul en ligne « RiPower » du configurateur de TGBT.



RiPower

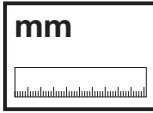
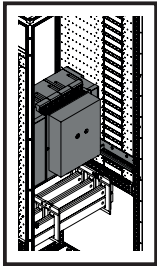

DE EN FR



1. Montage 4-poliges HSS
1. Fitting the 4-pole MBS
1. Montage des JBP tétrapolaires

- 1.11 Montage des offenen Leistungsschalters
- 1.11 Fitting the circuit-breaker
- 1.11 Montage du disjoncteur de puissance

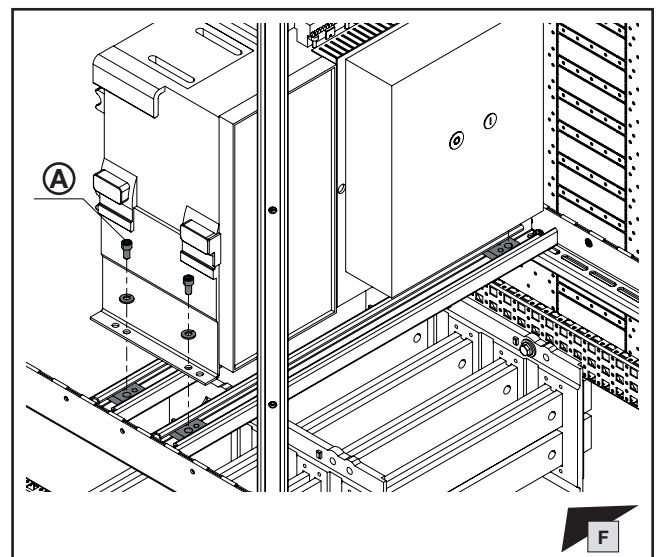
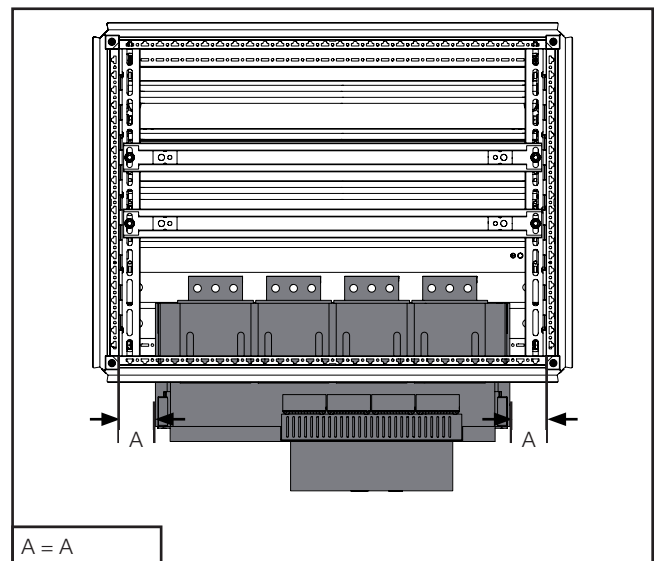
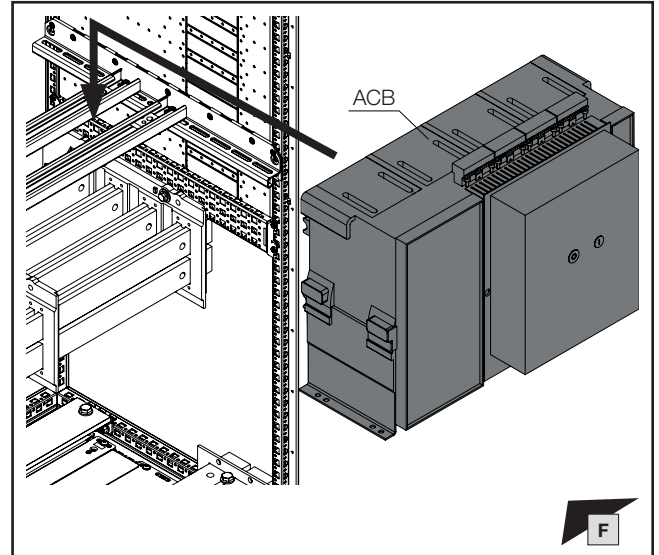
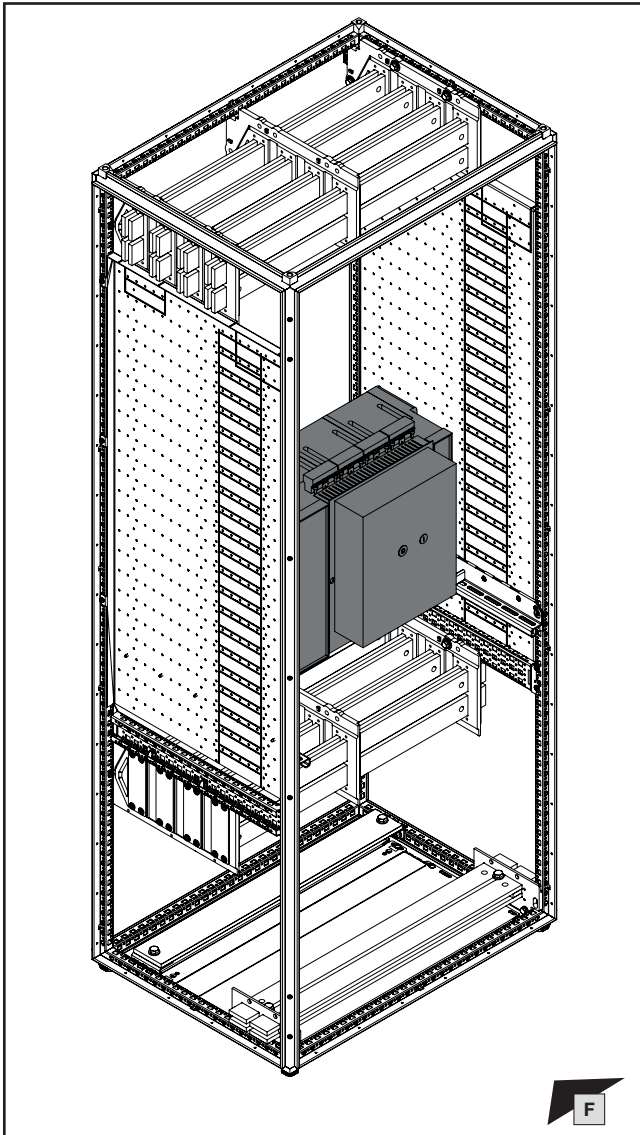

**Hinweis / Note / Remarque (A)**  
**Auswahl Befestigungsschrauben und Drehmomente gemäß Hersteller des ACB!**  
**Selection of fastening screws and torques in accordance with the manufacturer of the ACB!**  
**Choix des vis de fixation et des couples de serrage en fonction de la marque du disjoncteur de puissance !**

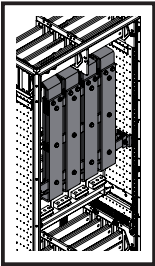

**1. Montage 4-poliges HSS**  
**1. Fitting the 4-pole MBS**  
**1. Montage des JBP tétrapolaires**

- 1.12 Montage des offenen Leistungsschalters – oberer Verbindungssatz
- 1.12 Fitting the circuit-breaker – Upper connector kit
- 1.12 Montage du disjoncteur de puissance – kit de jonction supérieur

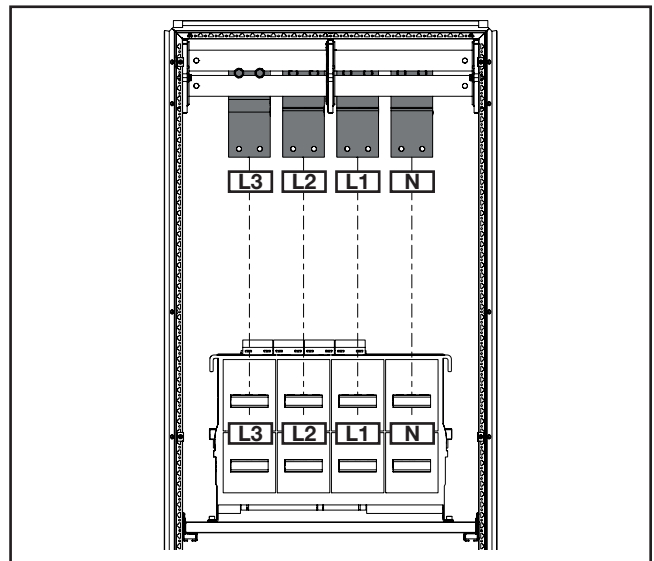
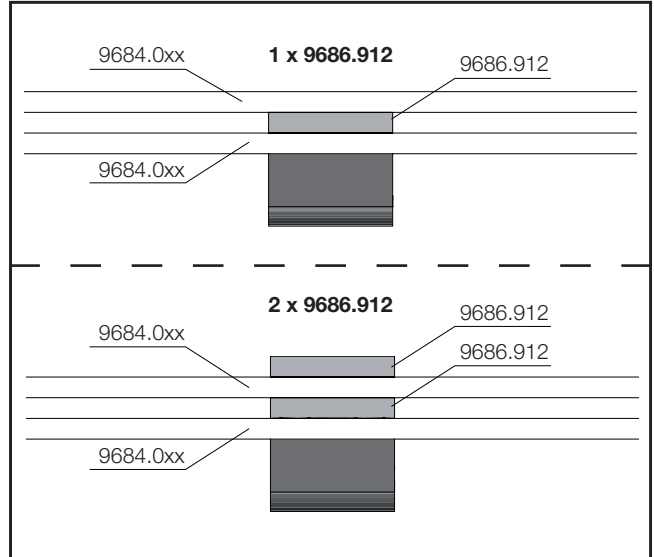
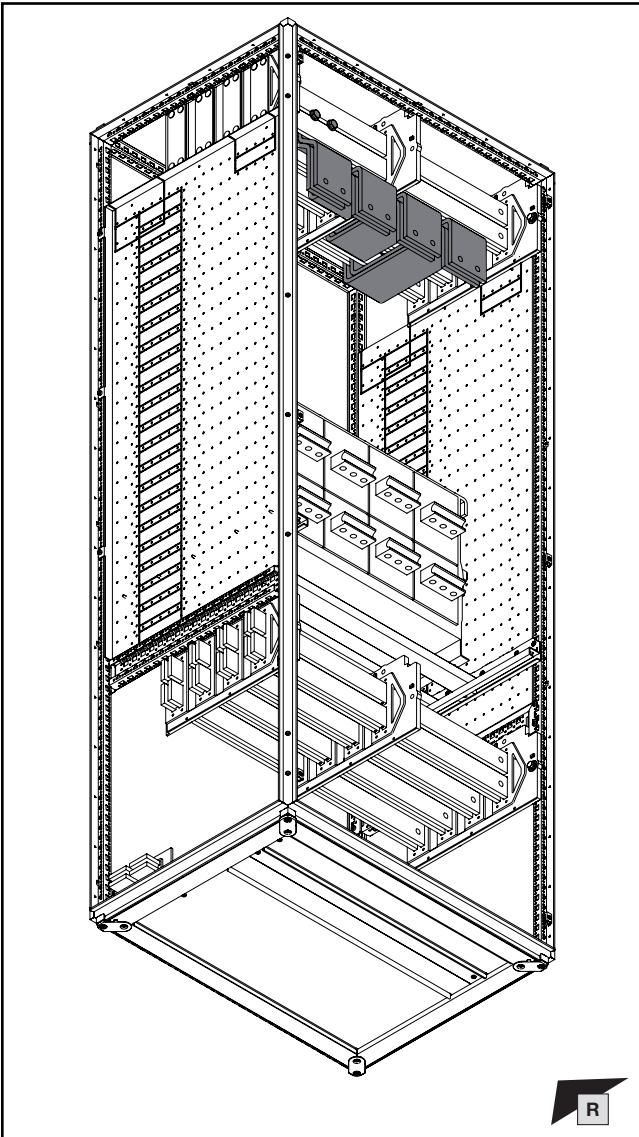

**Hinweis / Note / Remarque**  
**Montage 3-poliges Hauptsammelschienensystem N ungeschaltet: siehe Kapitel 5**  
**Fitting the 3-pole main busbar system N unswitched: see chapter 5**  
**Montage des jeux de barres principaux tripolaires Neutre non commandé : voir chapitre 5**



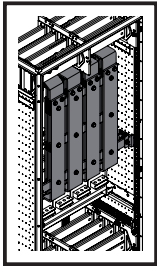

DE EN FR



1. Montage 4-poliges HSS
1. Fitting the 4-pole MBS
1. Montage des JBP tétrapolaires

1.12 Montage des offenen Leistungsschalters – oberer Verbindungssatz

1.12 Fitting the circuit-breaker – Upper connector kit

1.12 Montage du disjoncteur de puissance – kit de jonction supérieur

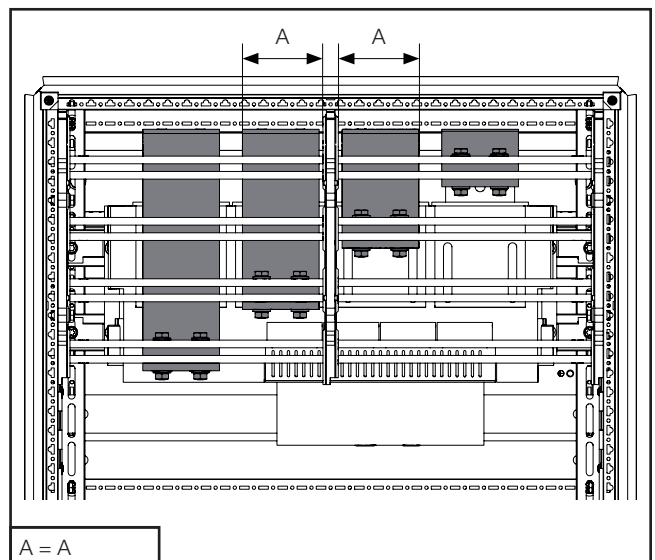
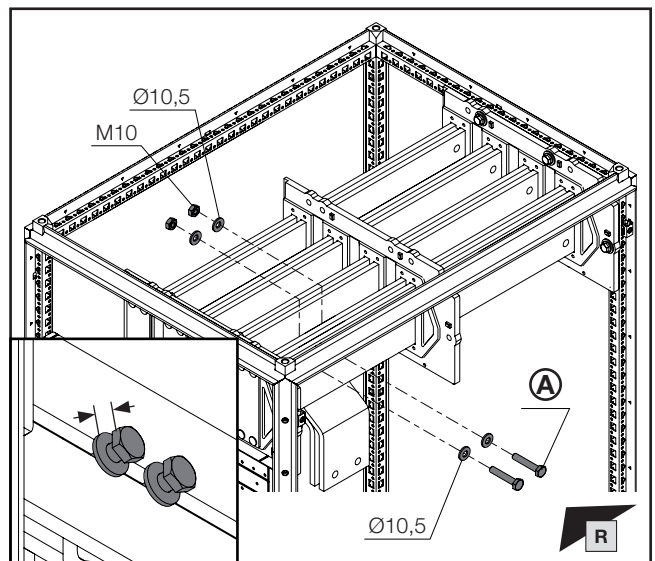
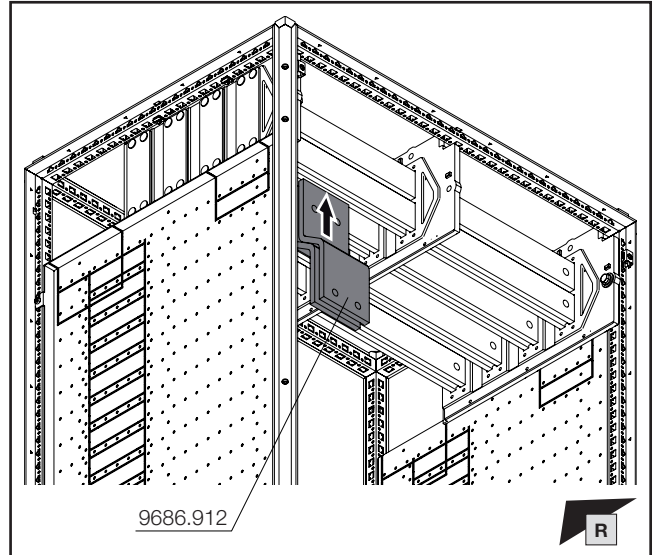
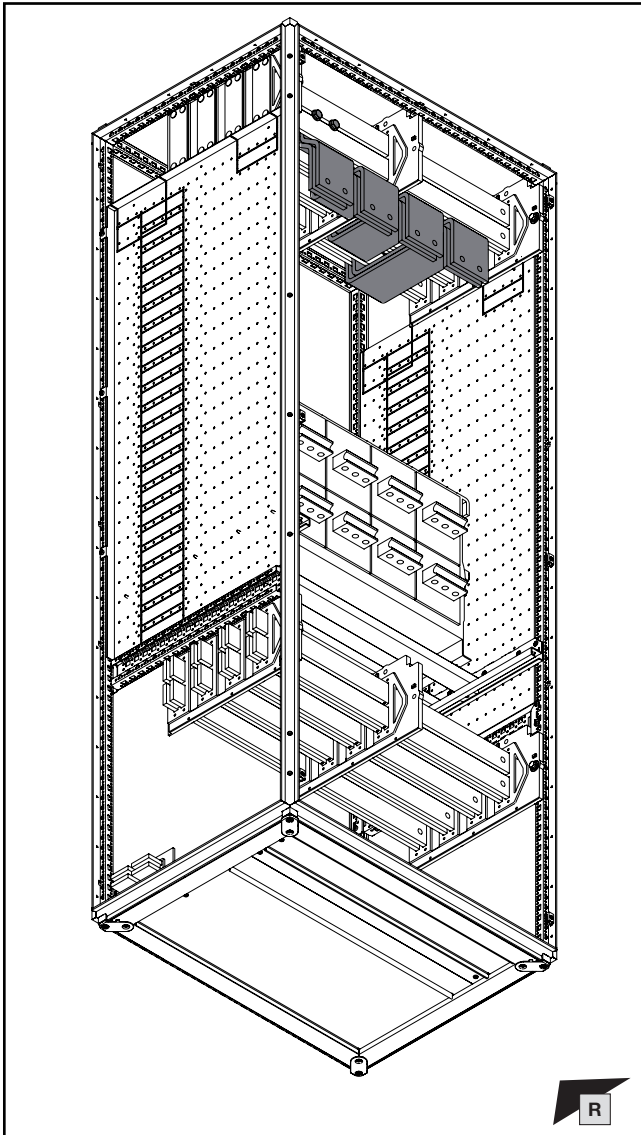

Hinweis / Note / Remarque

Gleichmäßige Ausrichtung sicherstellen!

Ensure uniform alignment!

S'assurer d'un alignement uniforme !

	Anzahl Number of Nombre de 9686.912	<sup>(A)</sup> Best.-Nr. Model No. Référence
M10 x 45	1	9686.845
M10 x 55	2	9686.865

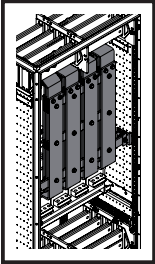

**1. Montage 4-poliges HSS**  
**1. Fitting the 4-pole MBS**  
**1. Montage des JBP tétrapolaires**

- 1.12 Montage des offenen Leistungsschalters – oberer Verbindungssatz
- 1.12 Fitting the circuit-breaker – Upper connector kit
- 1.12 Montage du disjoncteur de puissance – kit de jonction supérieur

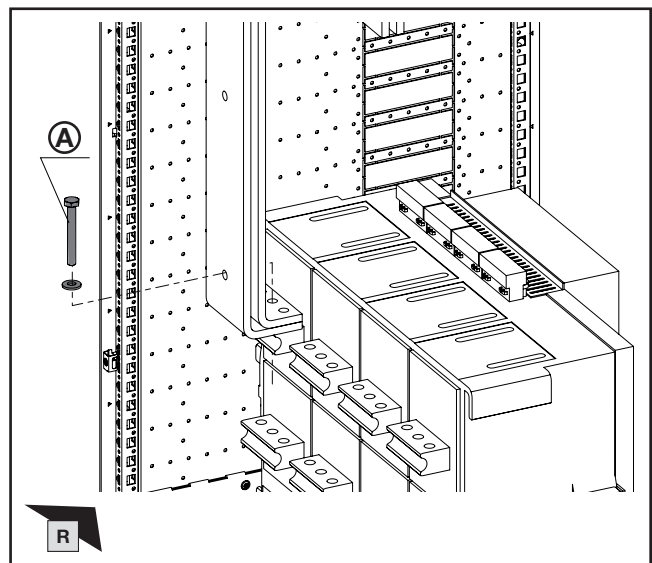
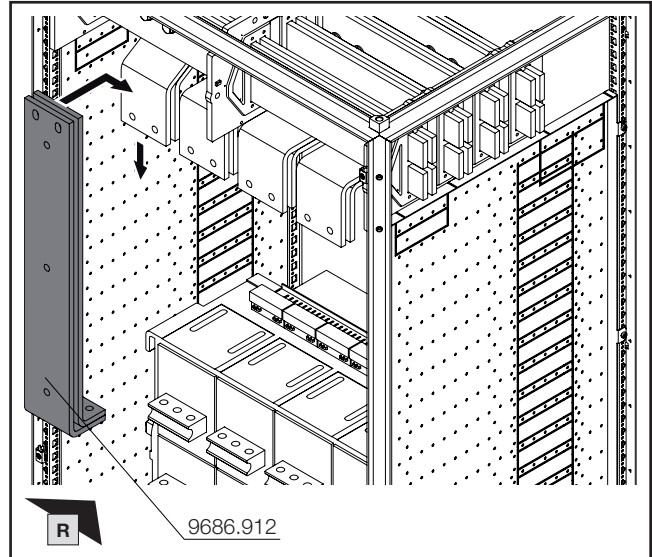
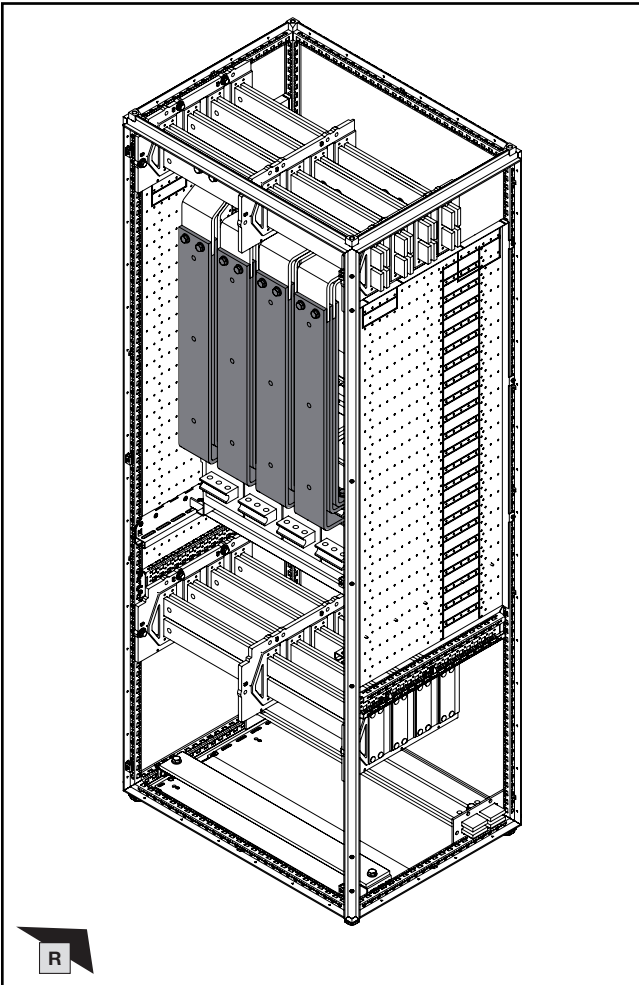

**Hinweis / Note / Remarque (A)**  
**Auswahl Befestigungsschrauben gemäß Hersteller des ACB!**  
**Selection of fastening screws in accordance with the manufacturer of the ACB!**  
**Choix des vis de fixation en fonction de la marque du disjoncteur de puissance !**

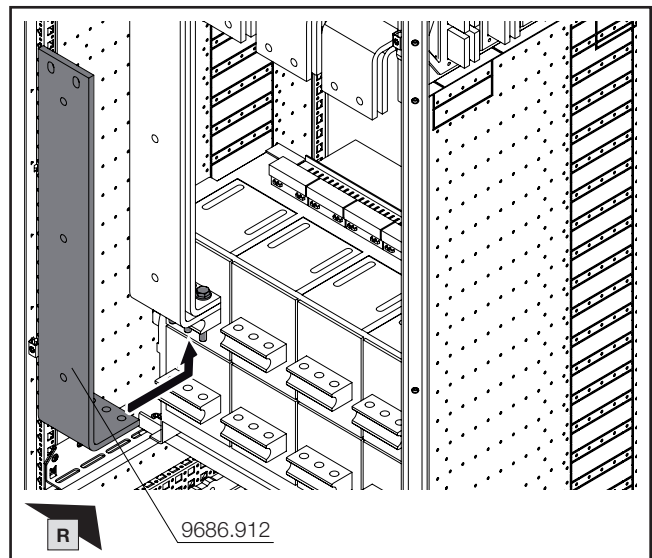
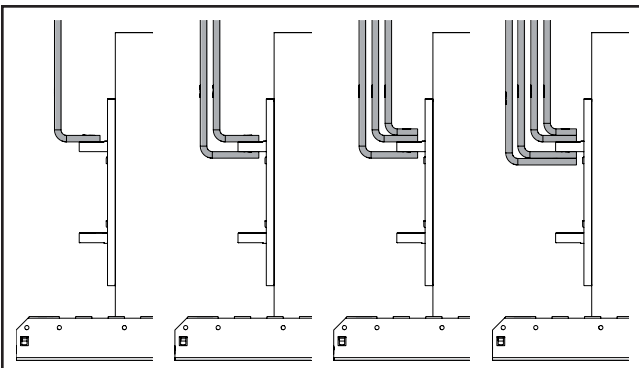

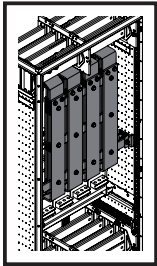

- 1. Montage 4-poliges HSS
- 1. Fitting the 4-pole MBS
- 1. Montage des JBP tétrapolaires

- 1.12 Montage des offenen Leistungsschalters – oberer Verbindungssatz
- 1.12 Fitting the circuit-breaker – Upper connector kit
- 1.12 Montage du disjoncteur de puissance – kit de jonction supérieur

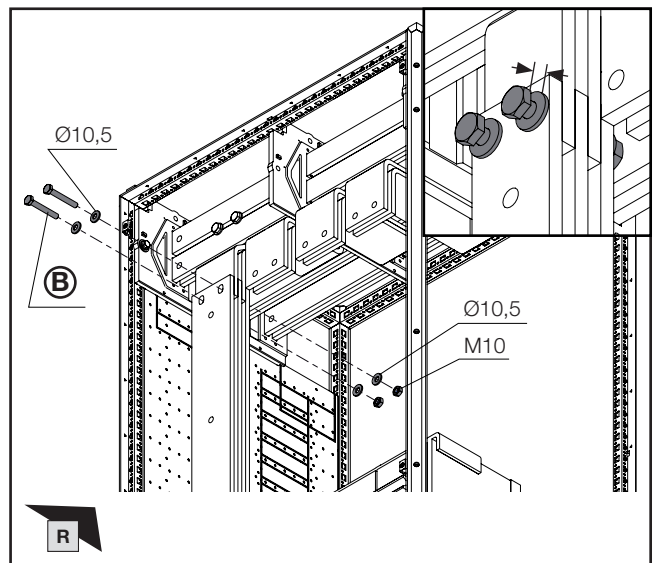
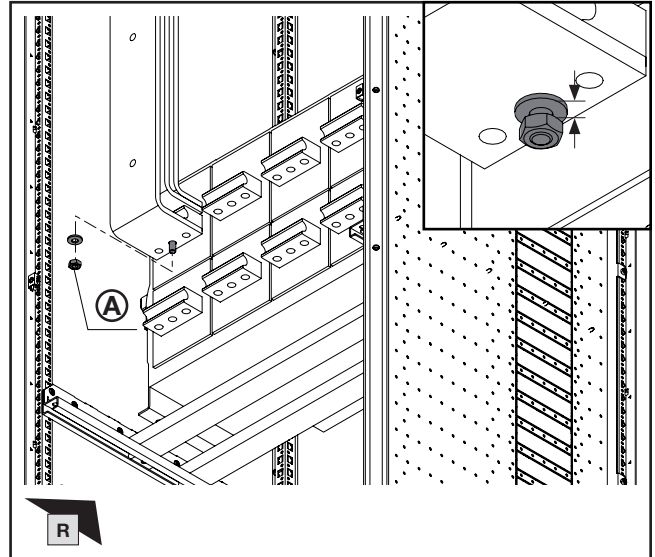
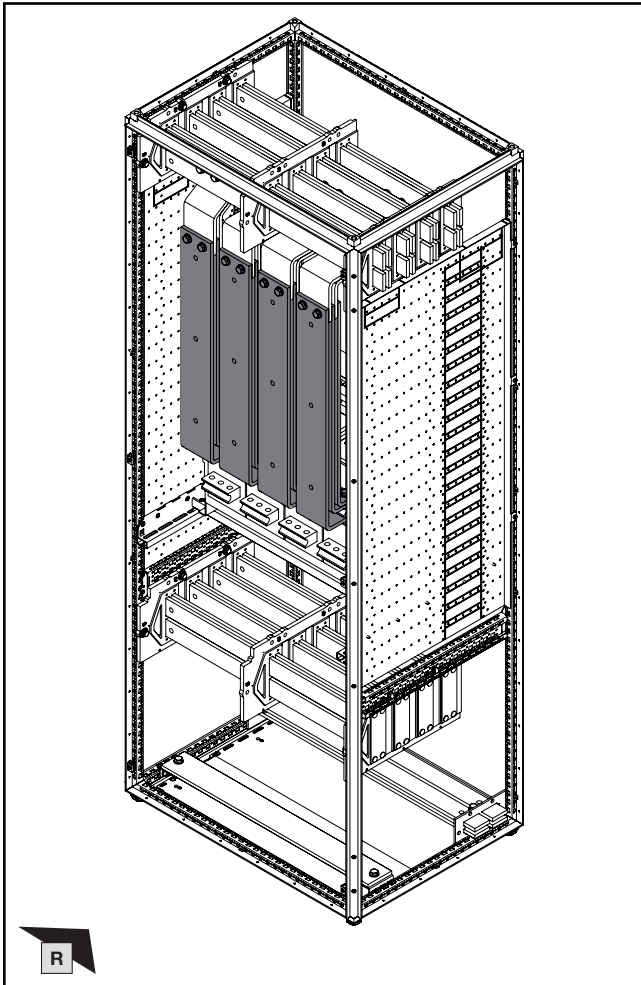

**Hinweis / Note / Remarque (A)**  
**Auswahl Befestigungsschrauben gemäß Hersteller des ACB!**  
**Selection of fastening screws in accordance with the manufacturer of the ACB!**  
**Choix des vis de fixation en fonction de la marque du disjoncteur de puissance !**

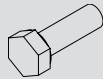
D mm	 L mm	(B) Best.-Nr. Model No. Référence
20	35	9686.830
40	55	9686.865
50	65	9686.855
70	85	9686.885

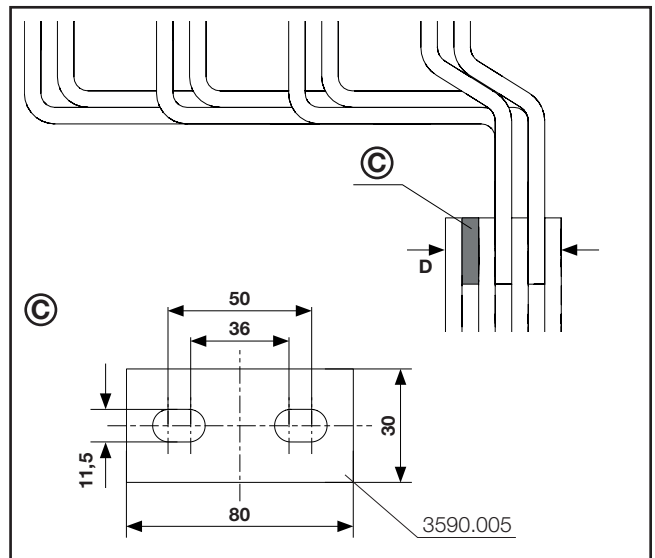

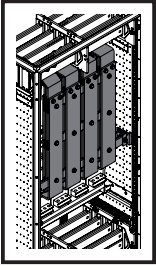

- 1. Montage 4-poliges HSS
- 1. Fitting the 4-pole MBS
- 1. Montage des JBP tétrapolaires

- 1.12 Montage des offenen Leistungsschalters – oberer Verbindungssatz
- 1.12 Fitting the circuit-breaker – Upper connector kit
- 1.12 Montage du disjoncteur de puissance – kit de jonction supérieur

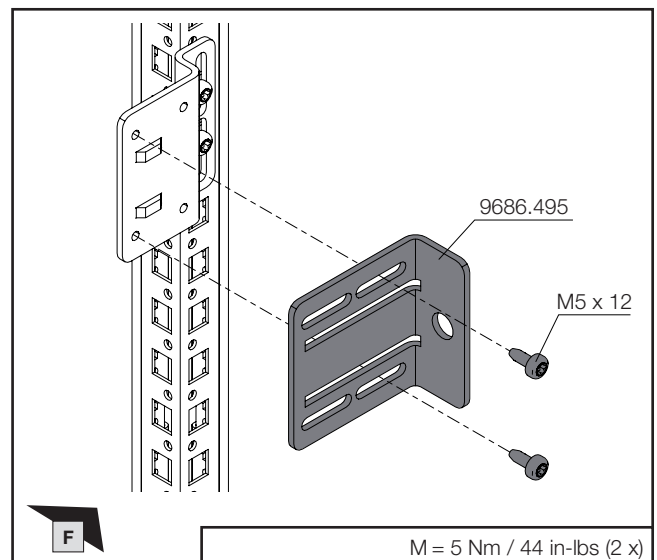
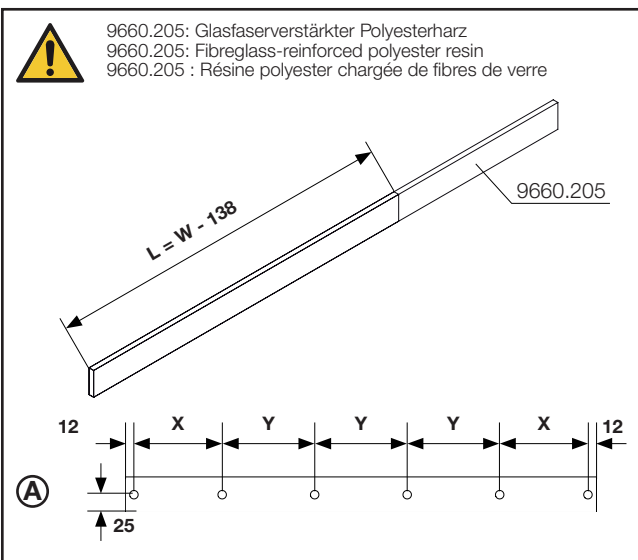
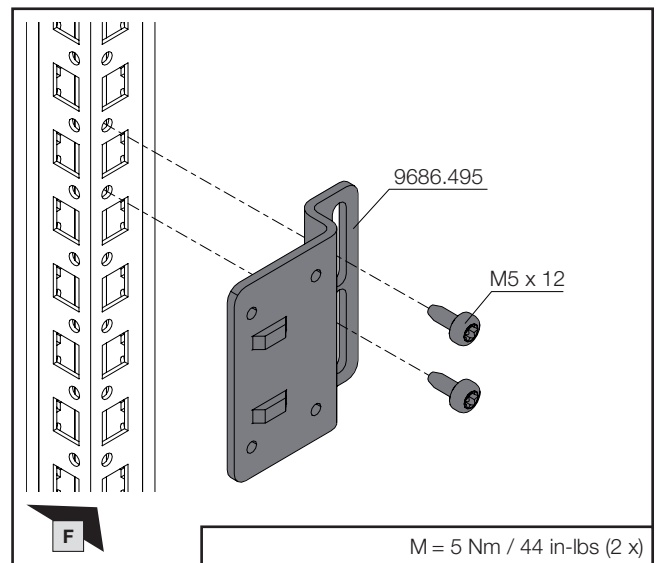
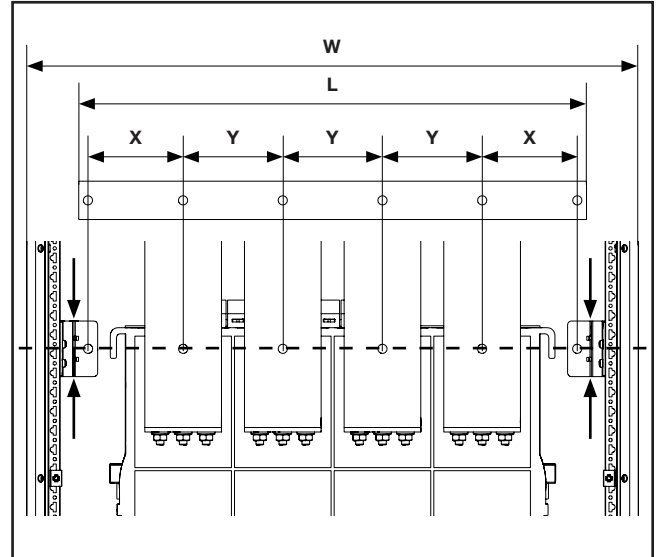
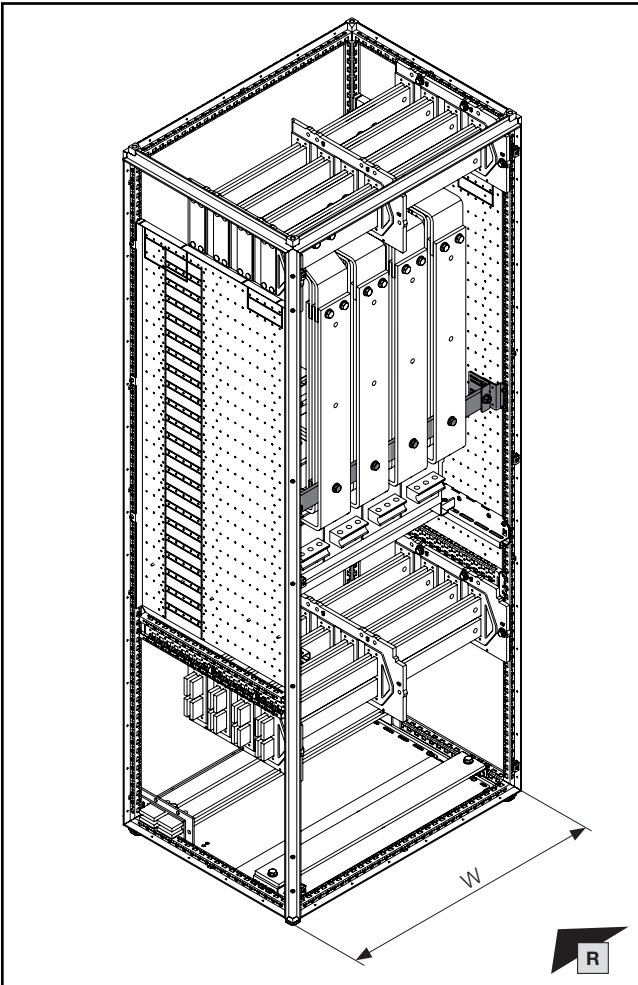

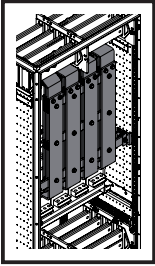

- 1. Montage 4-poliges HSS
- 1. Fitting the 4-pole MBS
- 1. Montage des JBP tétrapolaires

- 1.12 Montage des offenen Leistungsschalters – oberer Verbindungssatz
- 1.12 Fitting the circuit-breaker – Upper connector kit
- 1.12 Montage du disjoncteur de puissance – kit de jonction supérieur

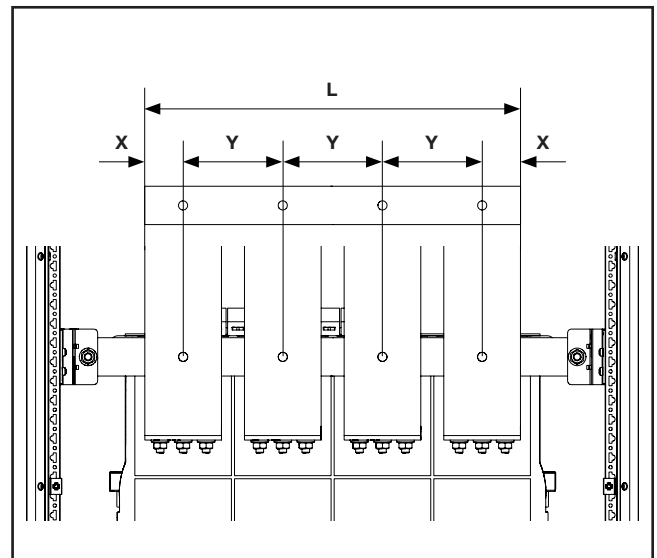
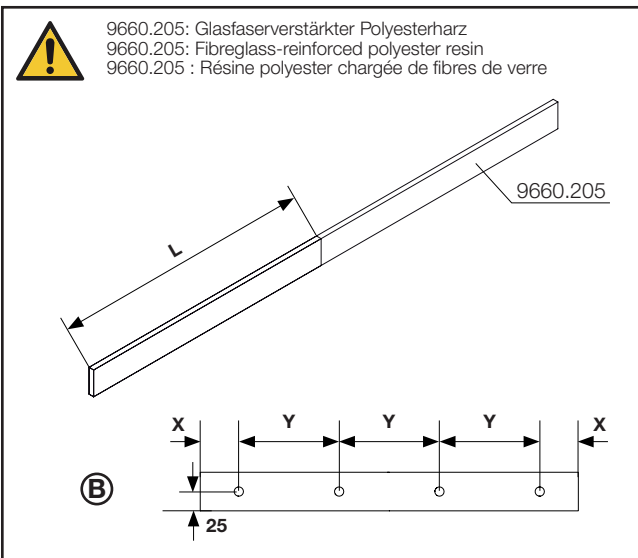
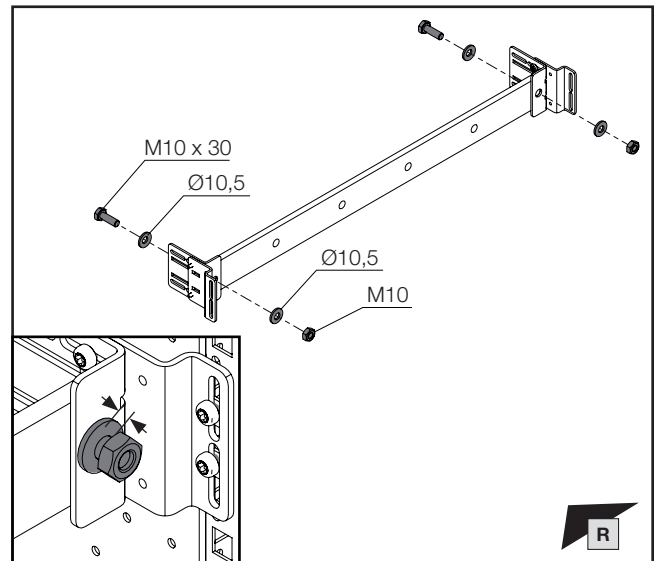
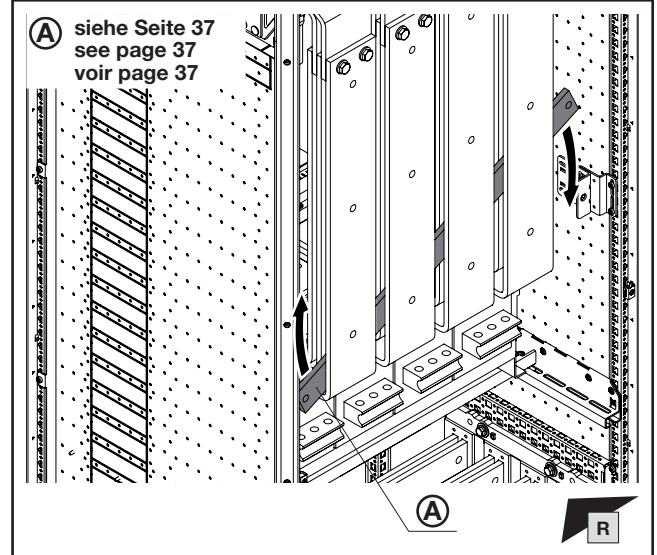
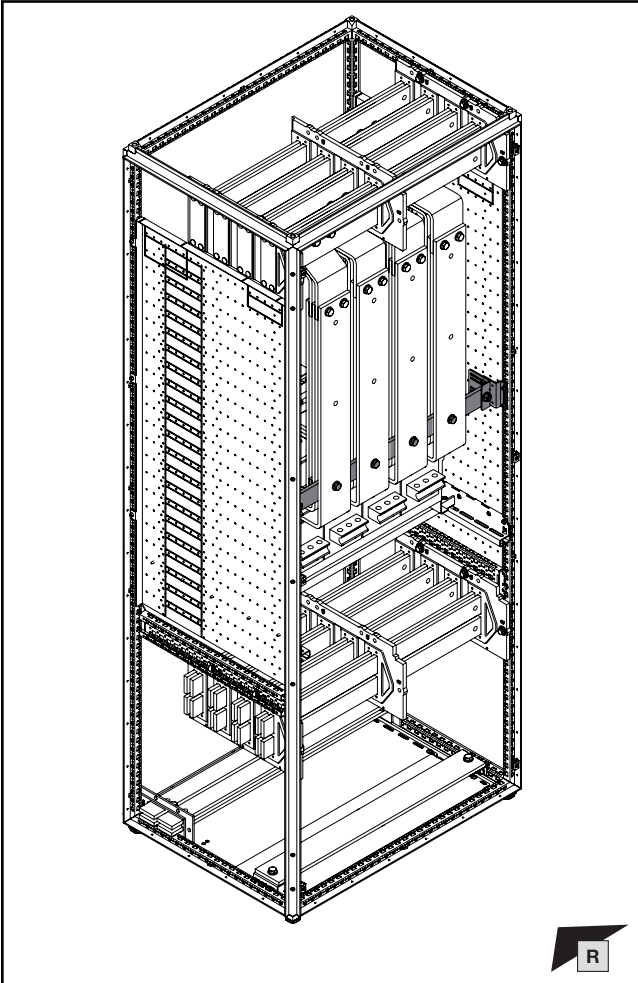

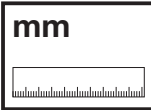
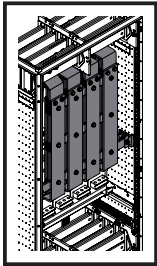

- 1. Montage 4-poliges HSS
- 1. Fitting the 4-pole MBS
- 1. Montage des JBP tétrapolaires

- 1.12 Montage des offenen Leistungsschalters – oberer Verbindungssatz
- 1.12 Fitting the circuit-breaker – Upper connector kit
- 1.12 Montage du disjoncteur de puissance – kit de jonction supérieur

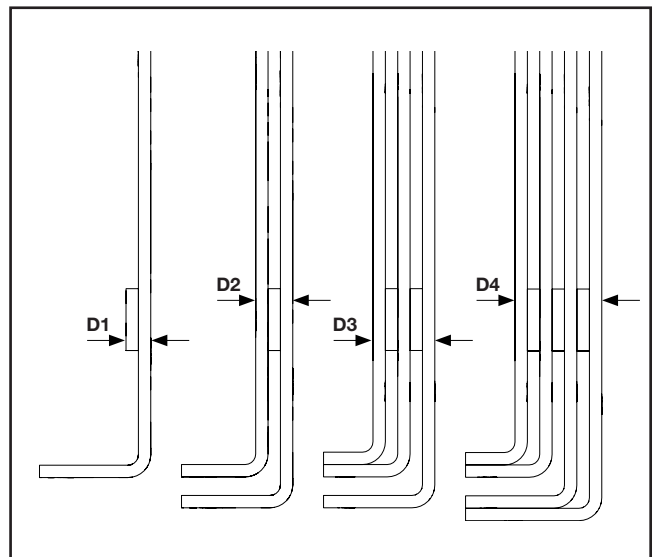
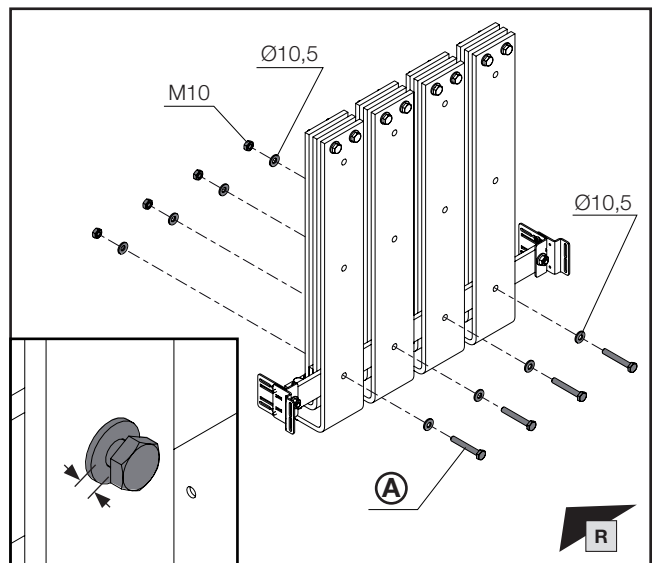
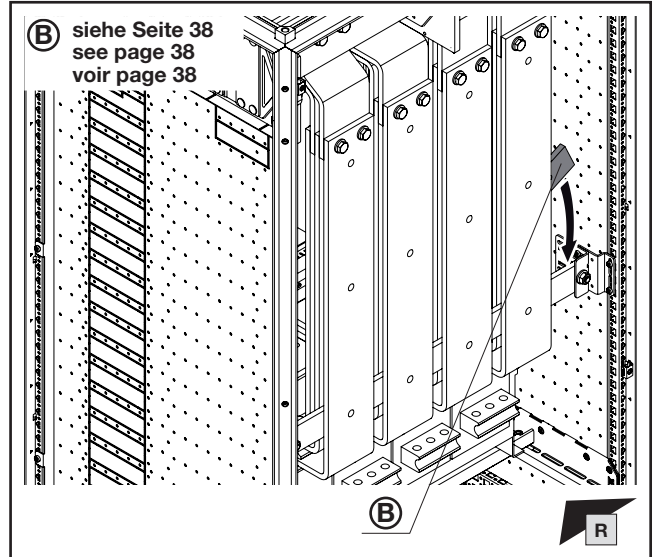
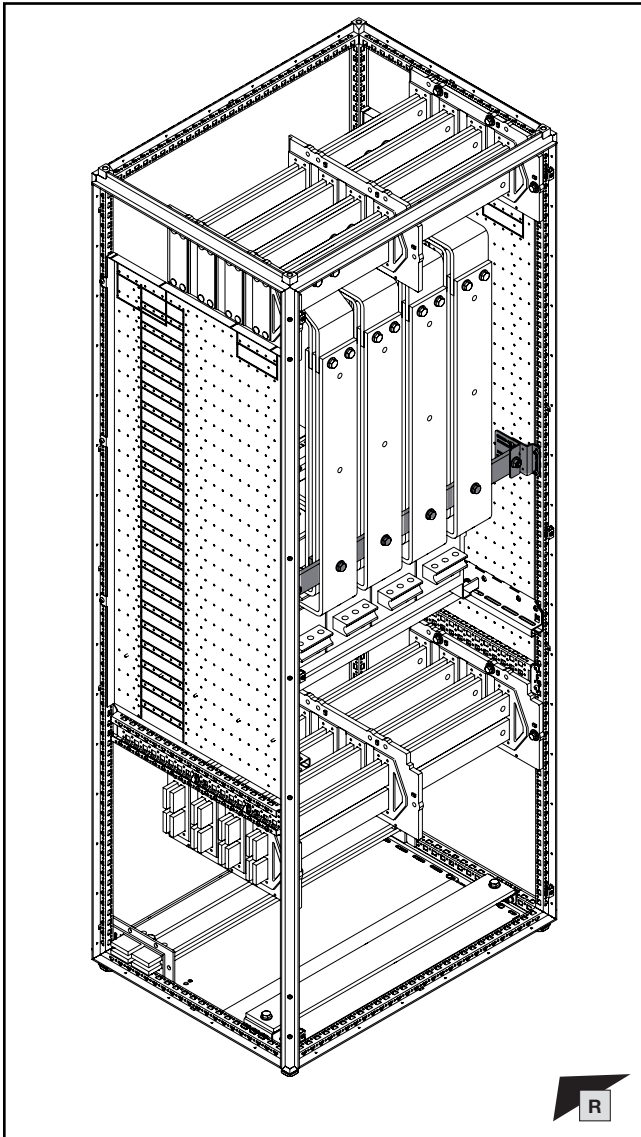

D mm			L mm	(A) Best.-Nr. Model No. Référence
D1	20		35	9686.830
D2	30	45	9686.845	
D3	50	65	9686.855	
D4	70	85	9686.885	

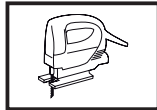
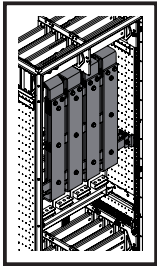

- 1. Montage 4-poliges HSS
- 1. Fitting the 4-pole MBS
- 1. Montage des JBP tétrapolaires

- 1.12 Montage des offenen Leistungsschalters – oberer Verbindungssatz
- 1.12 Fitting the circuit-breaker – Upper connector kit
- 1.12 Montage du disjoncteur de puissance – kit de jonction supérieur

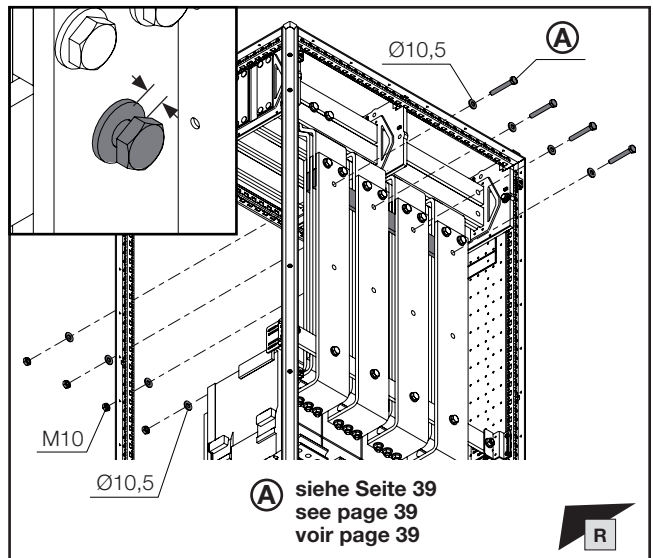
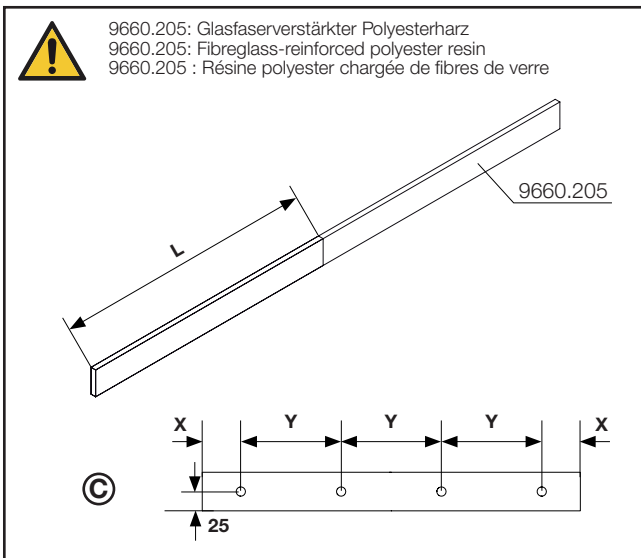
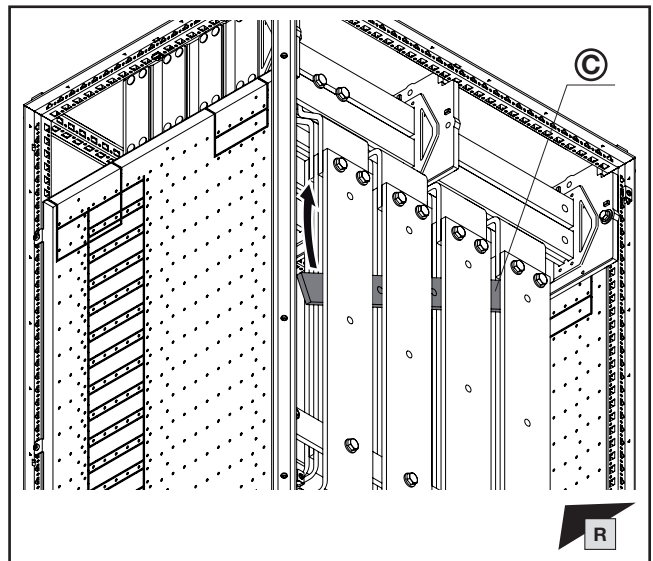
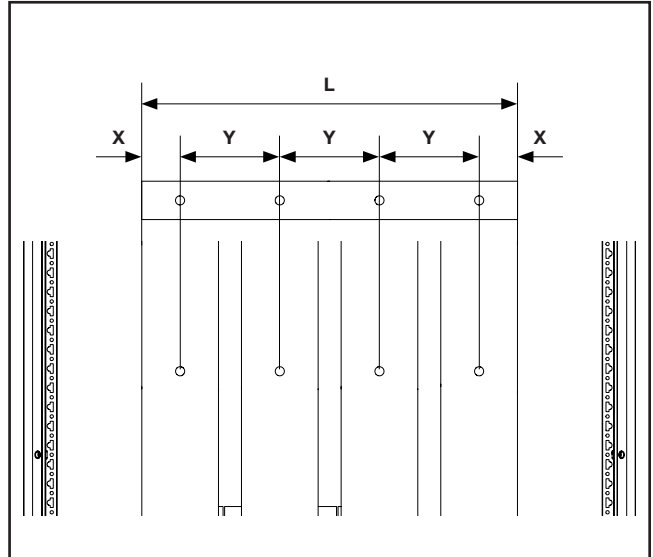
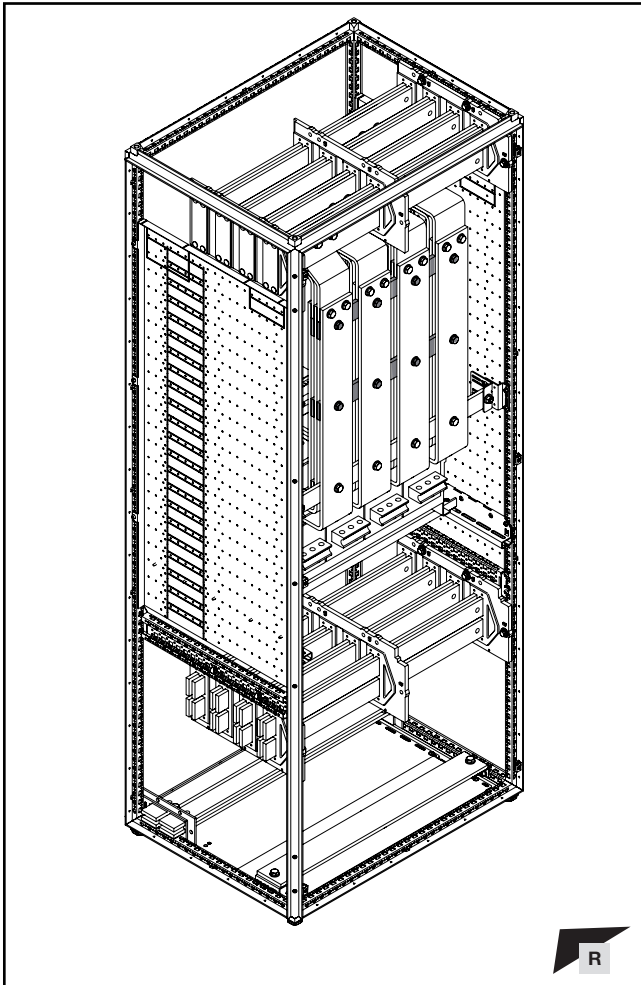

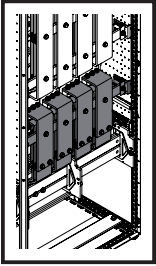

**1. Montage 4-poliges HSS**  
**1. Fitting the 4-pole MBS**  
**1. Montage des JBP tétrapolaires**

- 1.13 Montage des offenen Leistungsschalters – unterer Verbindungssatz
- 1.13 Fitting the circuit-breaker – Lower connector kit
- 1.13 Montage du disjoncteur de puissance – kit de jonction inférieur

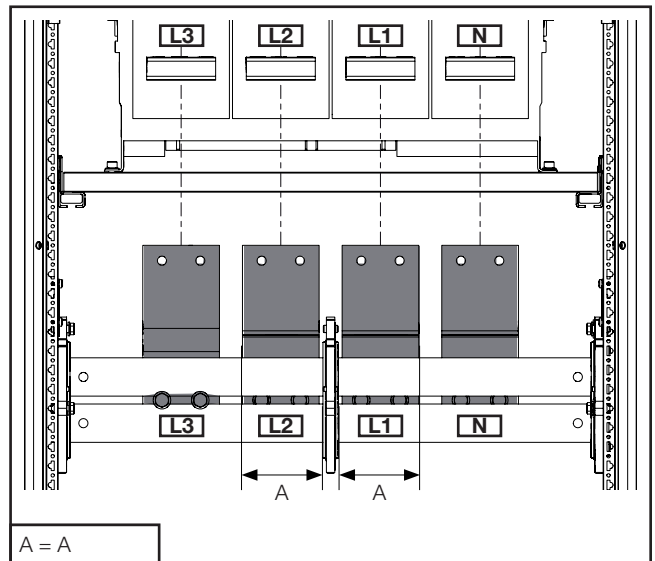
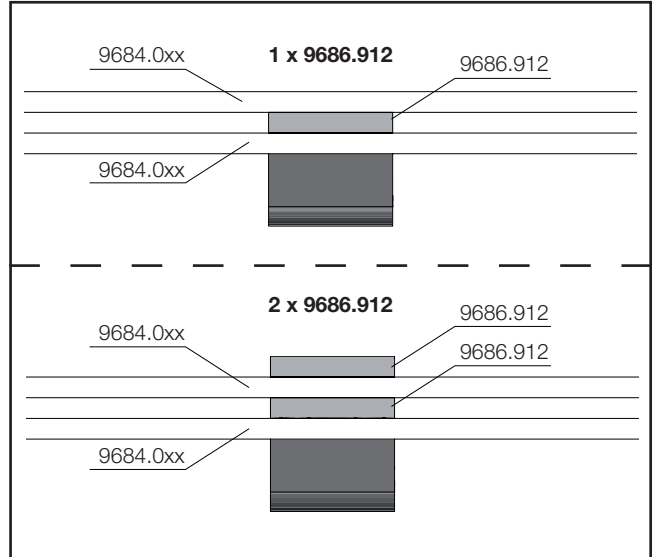
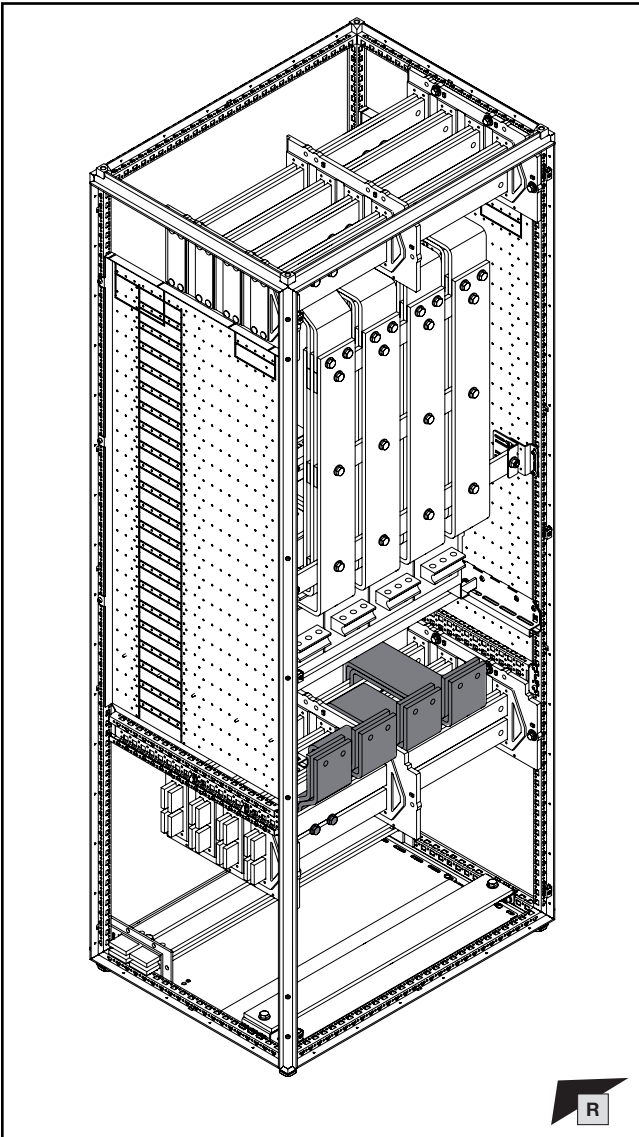

**Hinweis / Note / Remarque**  
**Montage des offenen Leistungsschalters 3-poliges Hauptsammelschienensystem: siehe Kapitel 5**  
**Fitting the circuit-breaker 3-pole main busbar system: see chapter 5**  
**Montage du disjoncteur de puissance pour jeux de barres principaux tripolaires : voir chapitre 5**



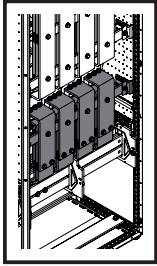

- 1. Montage 4-poliges HSS
- 1. Fitting the 4-pole MBS
- 1. Montage des JBP tétrapolaires

- 1.13 Montage des offenen Leistungsschalters – unterer Verbindungssatz
- 1.13 Fitting the circuit-breaker – Lower connector kit
- 1.13 Montage du disjoncteur de puissance – kit de jonction inférieur

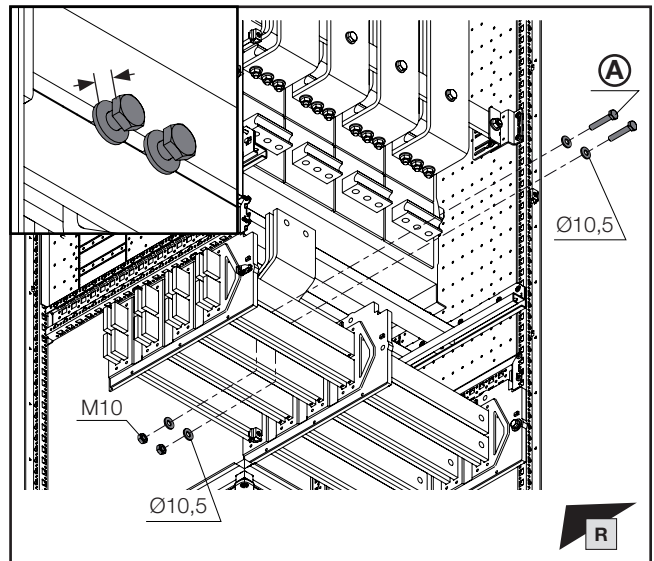
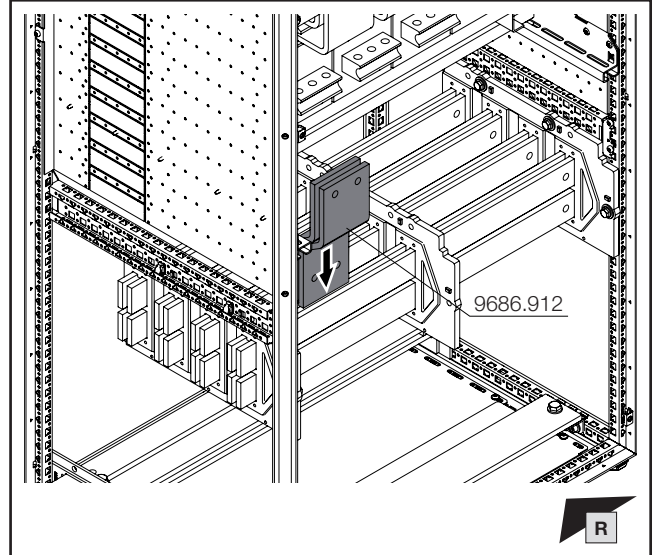
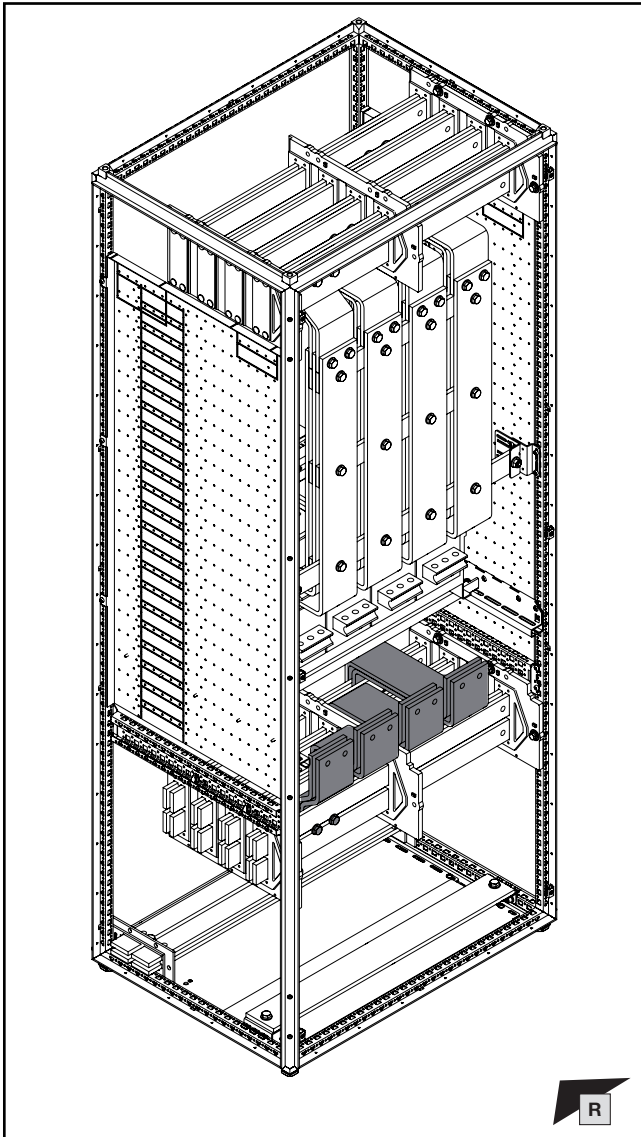

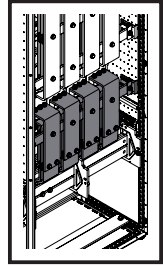

	Anzahl Number of Nombre de 9686.912	<sup>(A)</sup> Best.-Nr. Model No. Référence
M10 x 45	1	9686.845
M10 x 55	2	9686.865

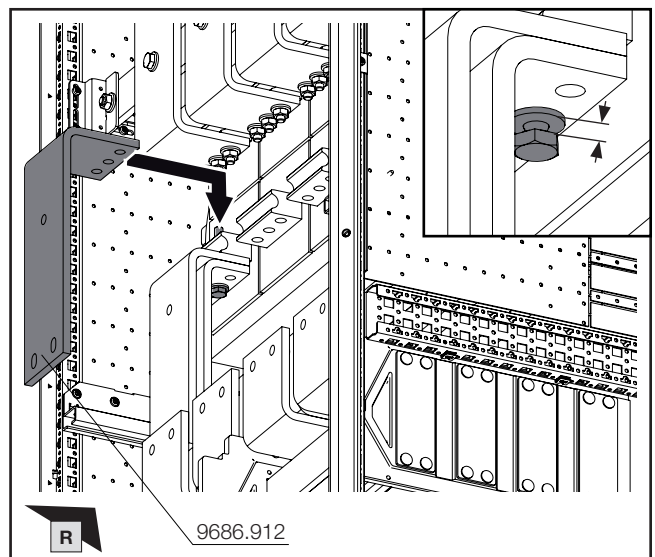
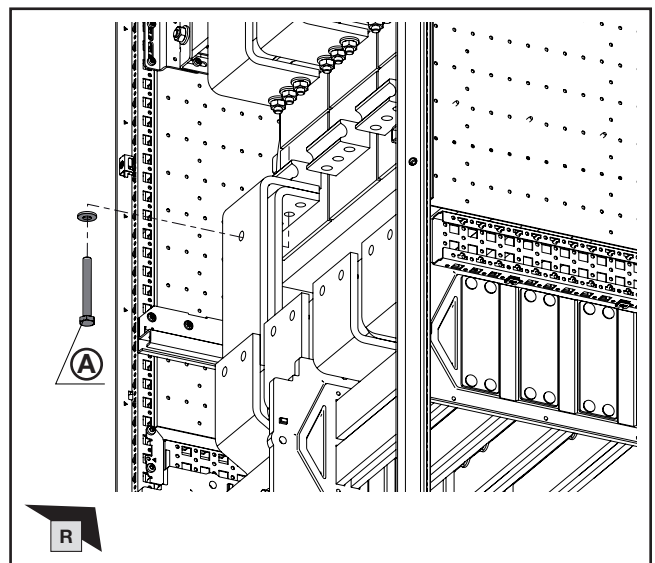
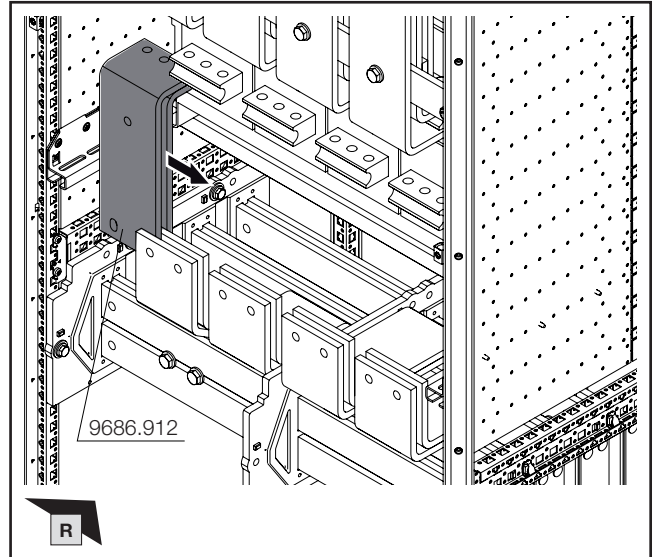
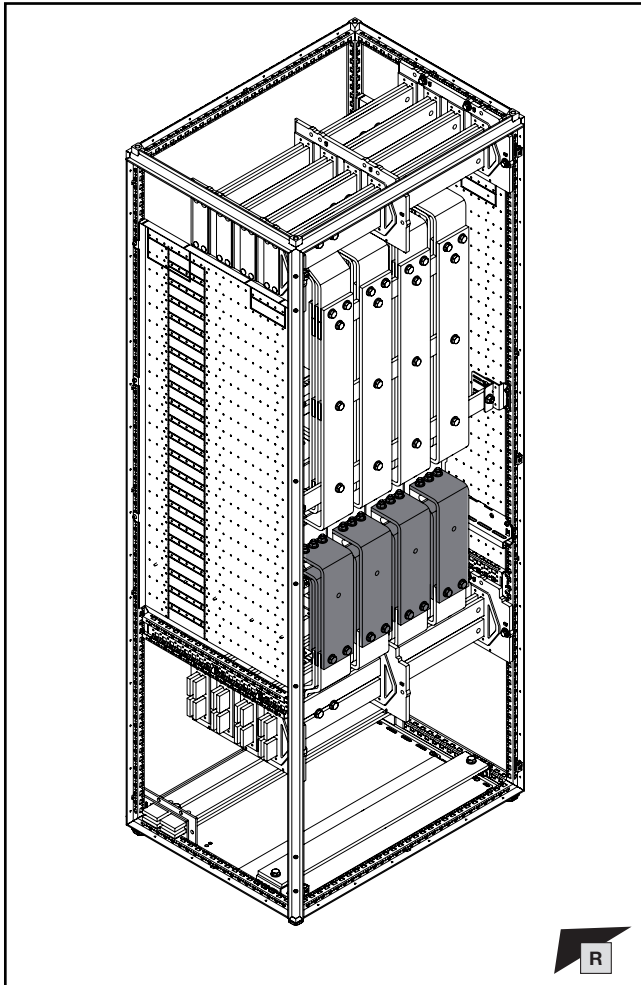

1. Montage 4-poliges HSS  
 1. Fitting the 4-pole MBS  
 1. Montage des JBP tétrapolaires

- 1.13 Montage des offenen Leistungsschalters – unterer Verbindungssatz
- 1.13 Fitting the circuit-breaker – Lower connector kit
- 1.13 Montage du disjoncteur de puissance – kit de jonction inférieur



 **Hinweis / Note / Remarque (A)**  
**Auswahl Befestigungsschrauben gemäß Hersteller des ACB!**  
**Selection of fastening screws in accordance with the manufacturer of the ACB!**  
**Choix des vis de fixation en fonction de la marque du disjoncteur de puissance !**

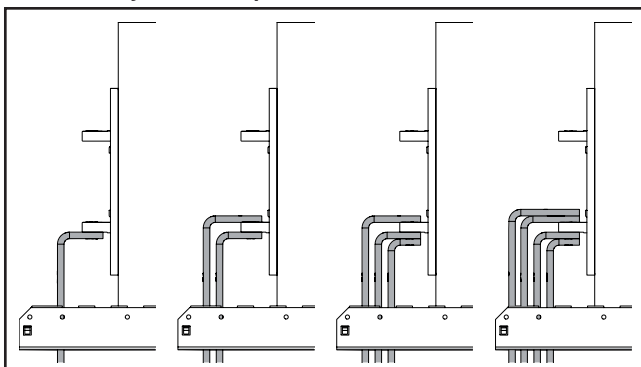

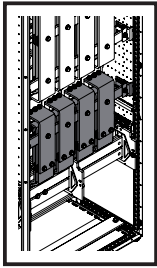

- 1. Montage 4-poliges HSS
- 1. Fitting the 4-pole MBS
- 1. Montage des JBP tétrapolaires

- 1.13 Montage des offenen Leistungsschalters – unterer Verbindungssatz
- 1.13 Fitting the circuit-breaker – Lower connector kit
- 1.13 Montage du disjoncteur de puissance – kit de jonction inférieur

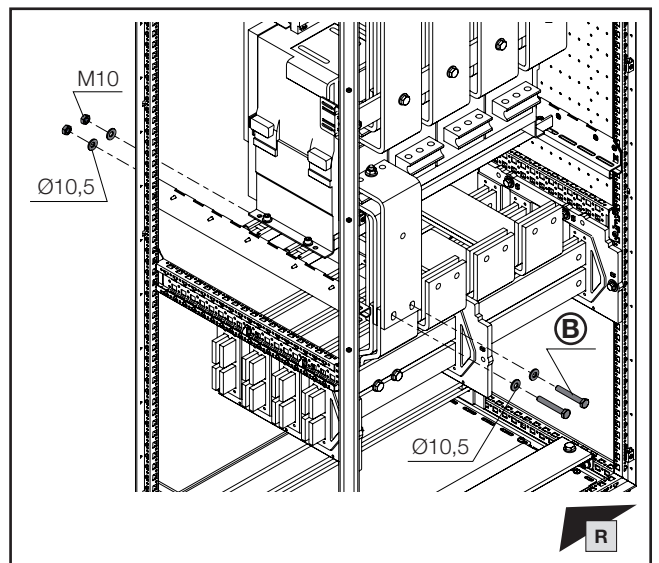
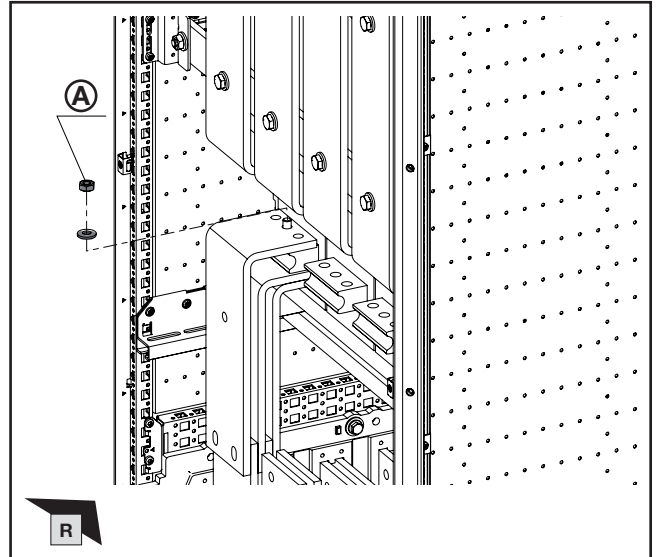
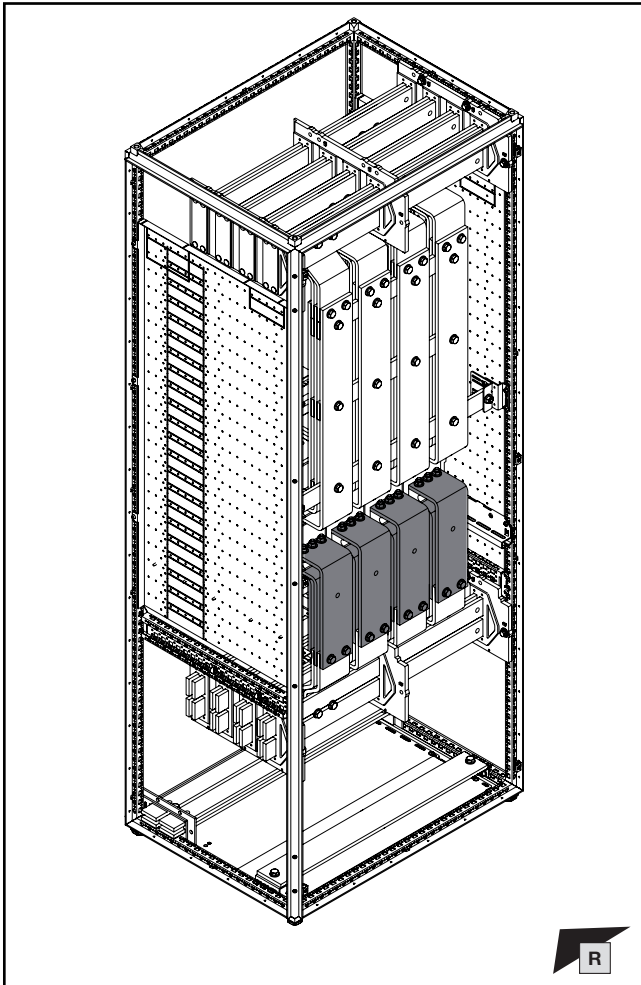

**Hinweis / Note / Remarque (A)**  
**Auswahl Befestigungsschrauben gemäß Hersteller des ACB!**  
**Selection of fastening screws in accordance with the manufacturer of the ACB!**  
**Choix des vis de fixation en fonction de la marque du disjoncteur de puissance !**

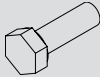
D mm	 L mm	(B) Best.-Nr. Model No. Référence
20	35	9686.830
40	55	9686.865
50	65	9686.855
70	85	9686.885

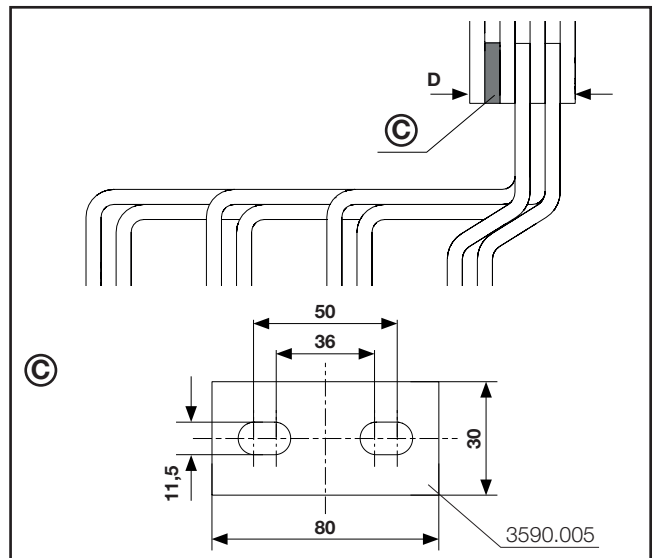

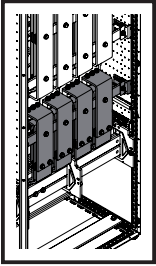

- 1. Montage 4-poliges HSS
- 1. Fitting the 4-pole MBS
- 1. Montage des JBP tétrapolaires

- 1.13 Montage des offenen Leistungsschalters – unterer Verbindungssatz
- 1.13 Fitting the circuit-breaker – Lower connector kit
- 1.13 Montage du disjoncteur de puissance – kit de jonction inférieur

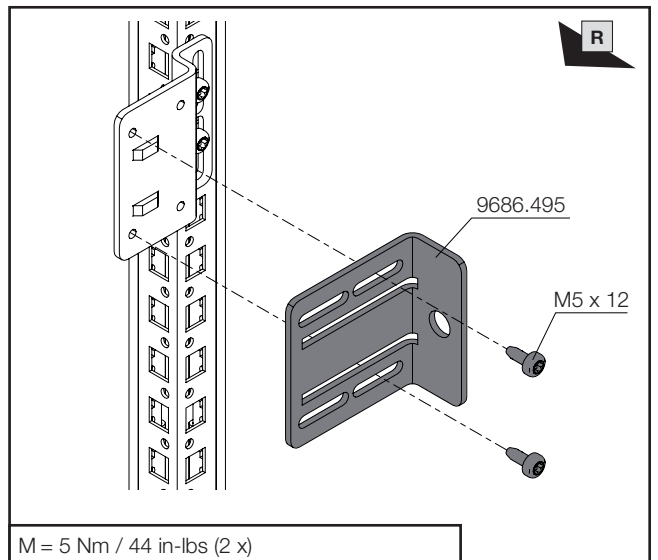
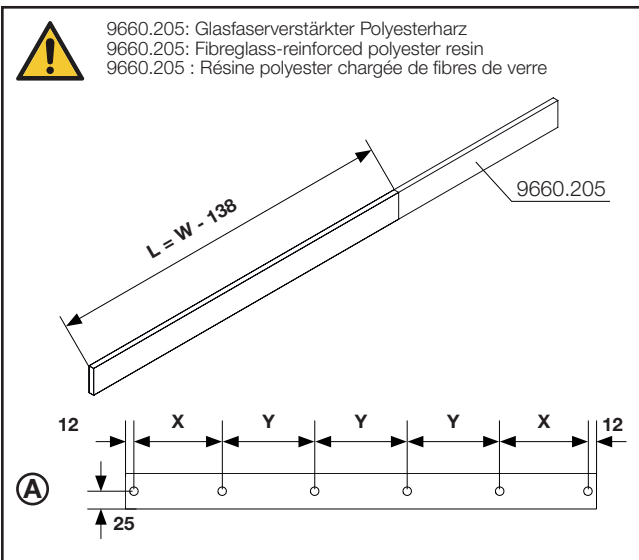
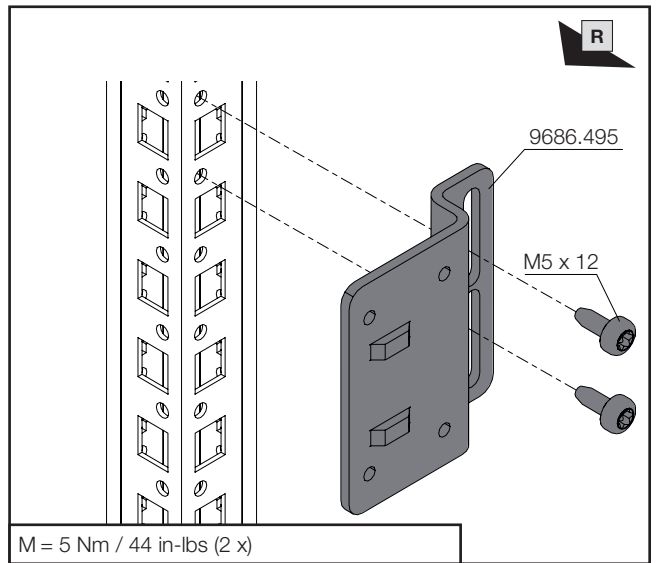
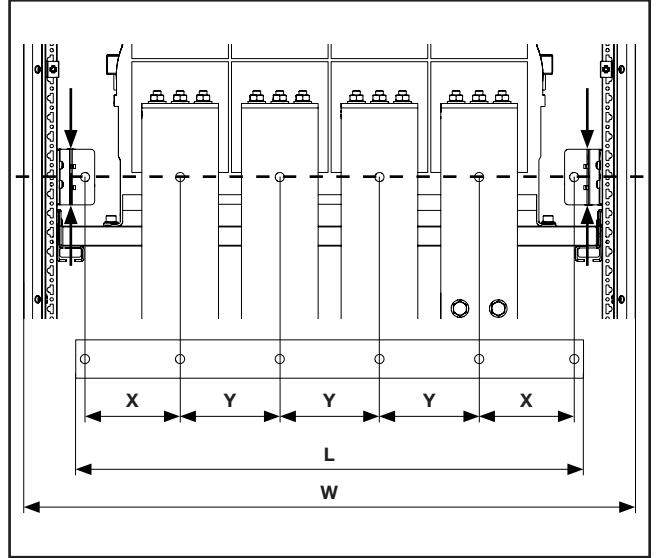
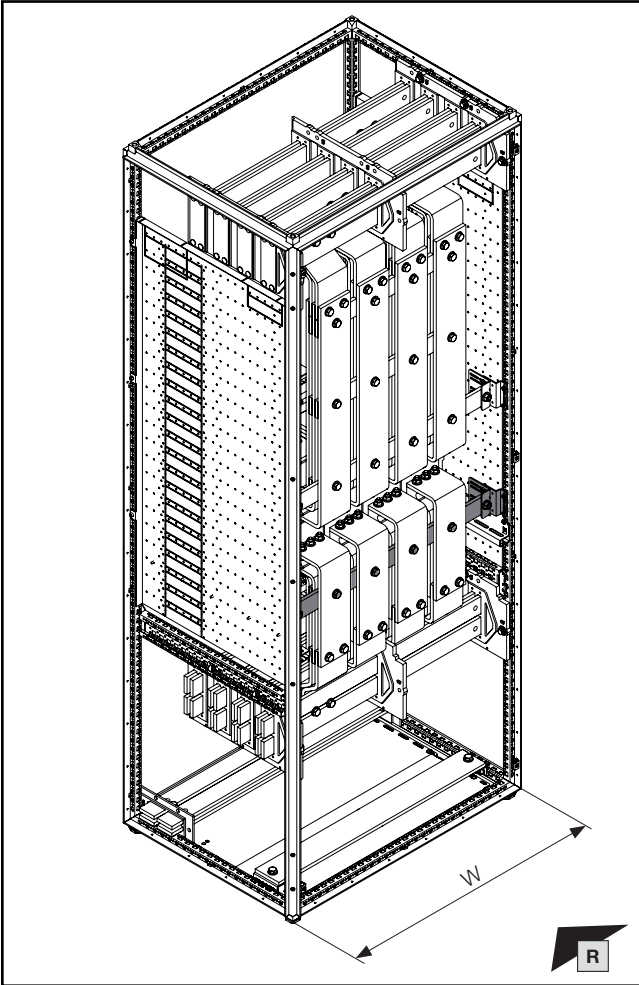

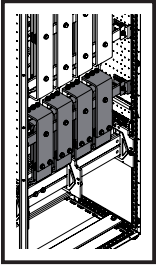

- 1. Montage 4-poliges HSS
- 1. Fitting the 4-pole MBS
- 1. Montage des JBP tétrapolaires

- 1.13 Montage des offenen Leistungsschalters – unterer Verbindungssatz
- 1.13 Fitting the circuit-breaker – Lower connector kit
- 1.13 Montage du disjoncteur de puissance – kit de jonction inférieur

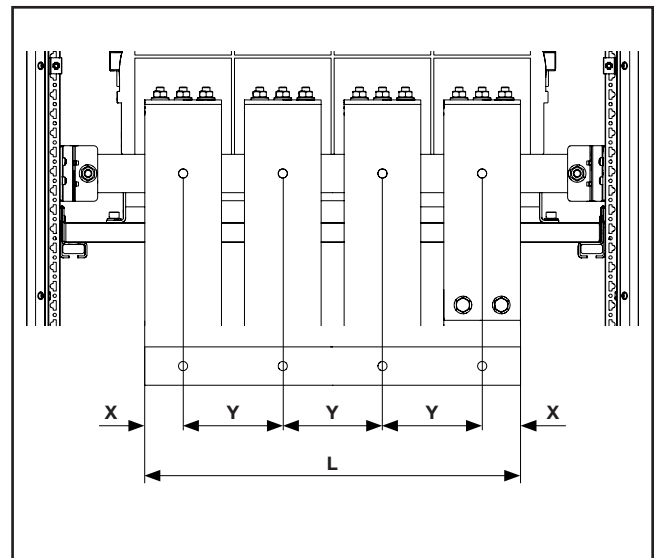
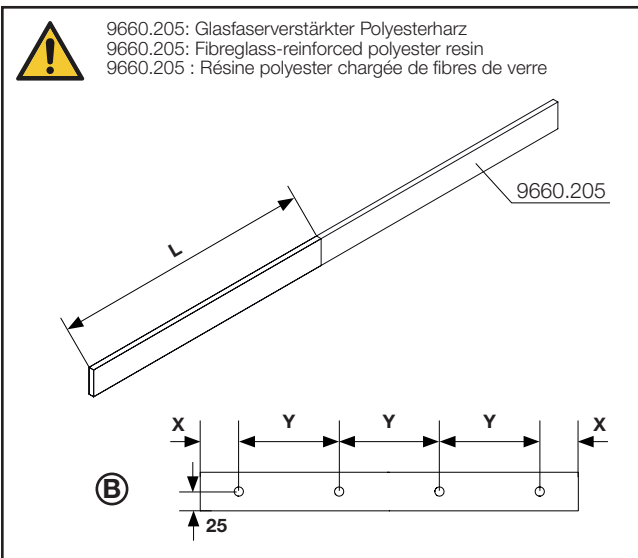
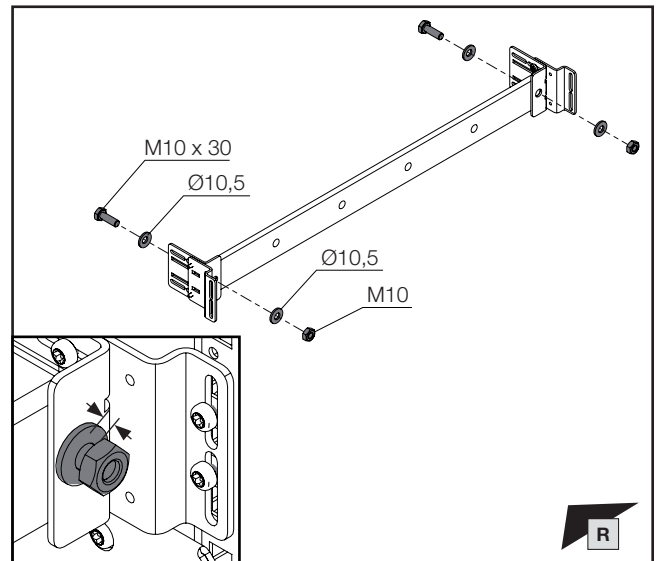
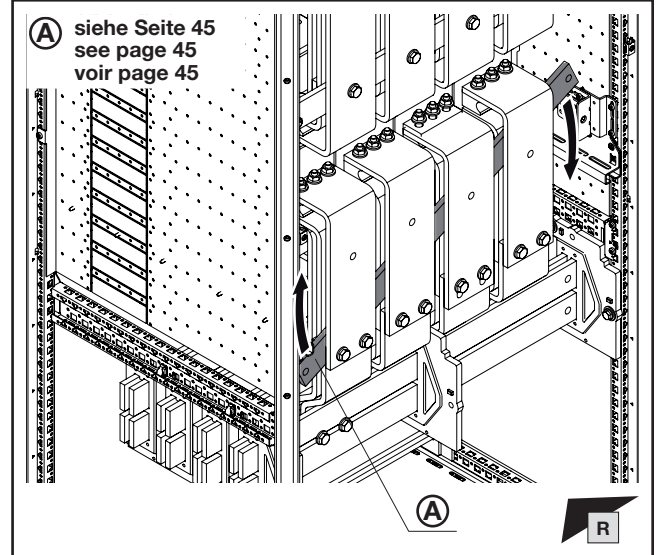
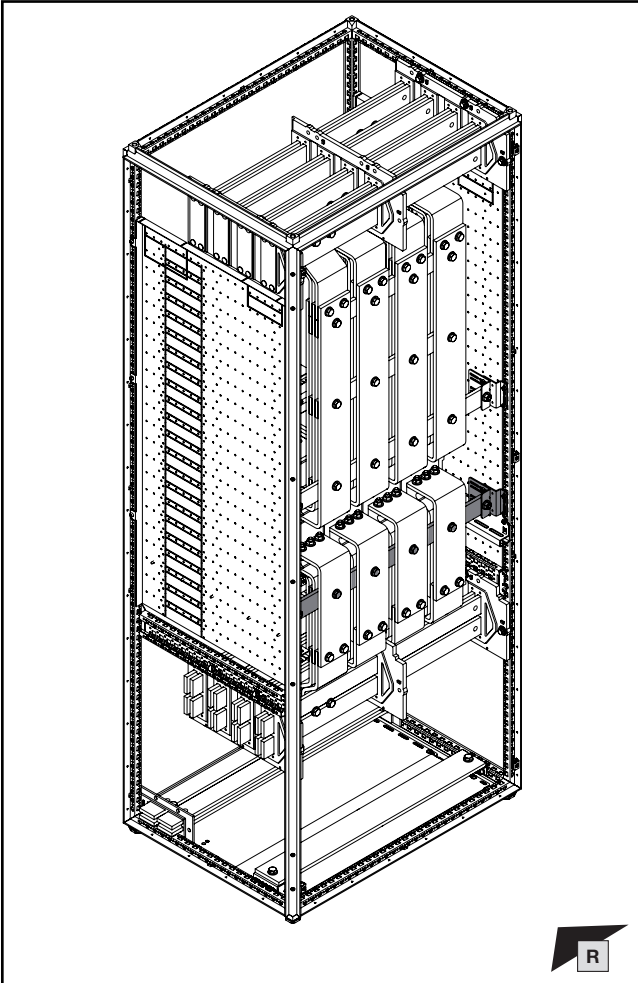

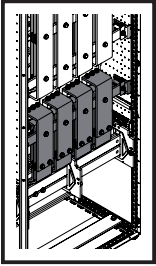

- 1. Montage 4-poliges HSS
- 1. Fitting the 4-pole MBS
- 1. Montage des JBP tétrapolaires

- 1.13 Montage des offenen Leistungsschalters – unterer Verbindungssatz
- 1.13 Fitting the circuit-breaker – Lower connector kit
- 1.13 Montage du disjoncteur de puissance – kit de jonction inférieur

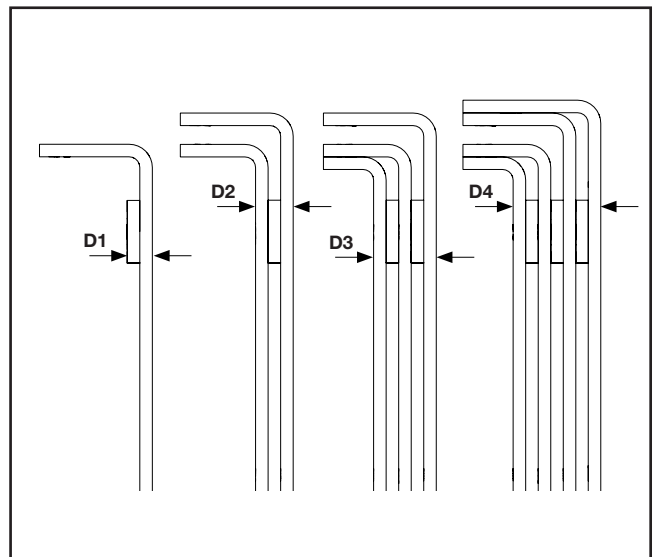
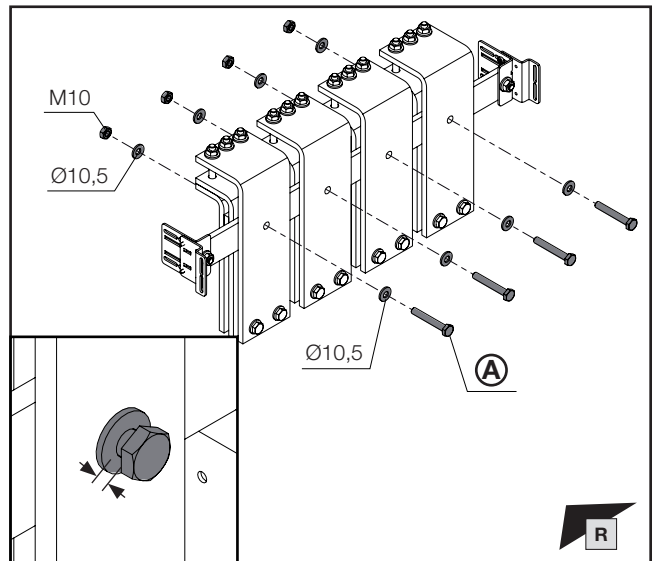
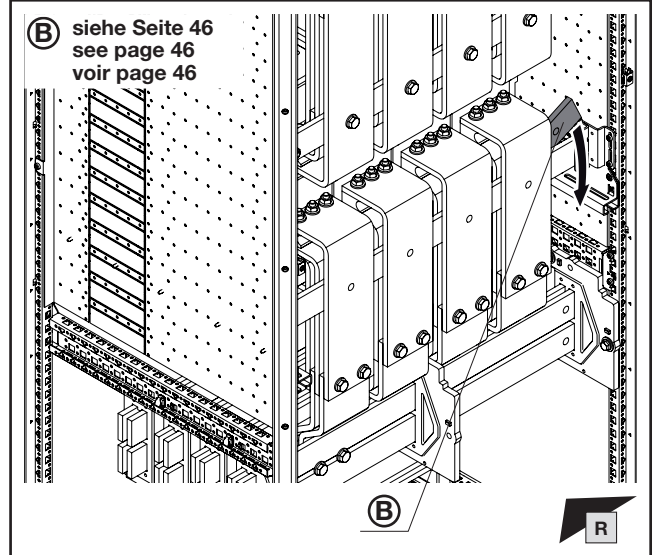
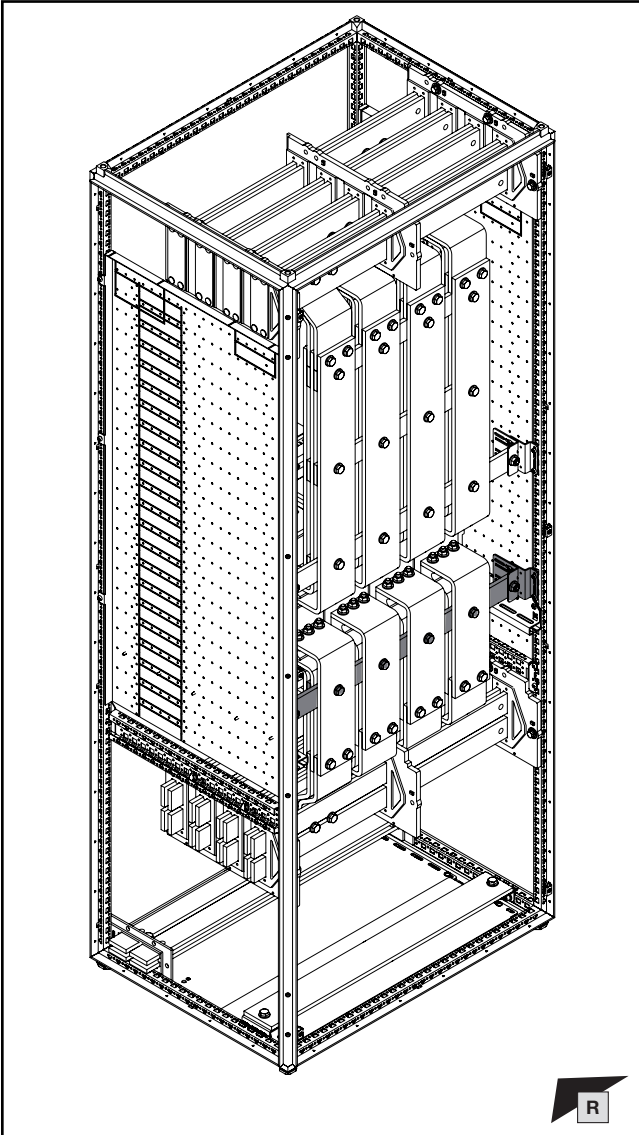

D mm	L mm	(A) Best.-Nr. Model No. Référence	
D1	20	35	9686.830
D2	30	45	9686.845
D3	50	65	9686.855
D4	70	85	9686.885

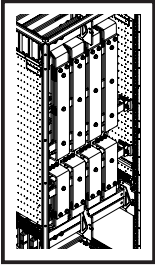



SW16/  
SW17

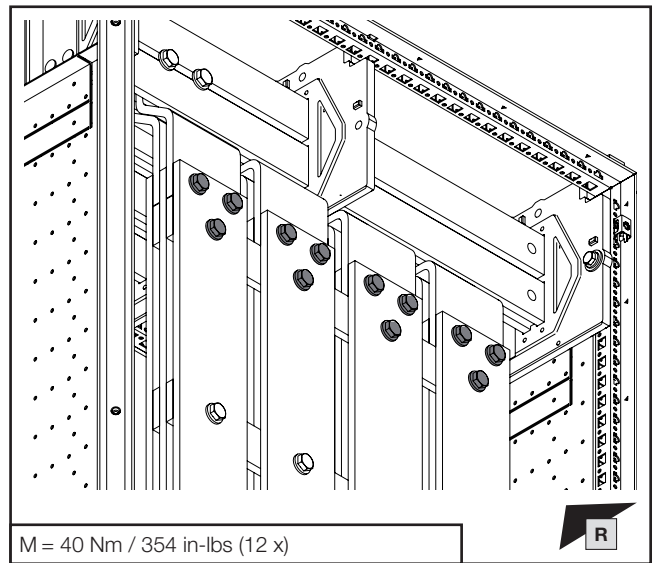
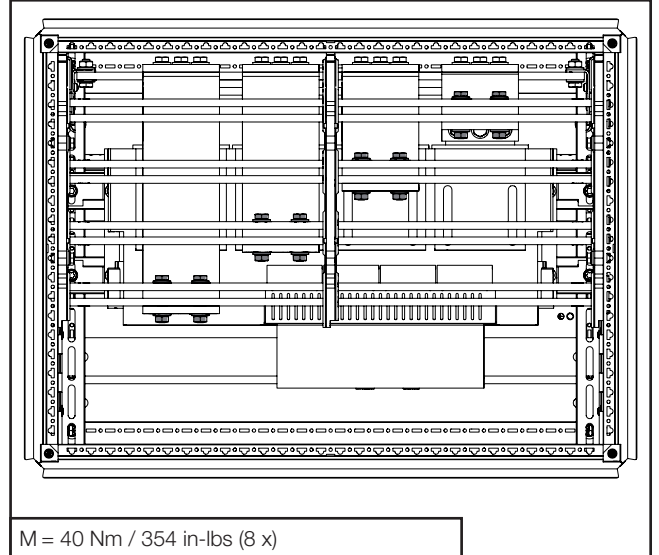
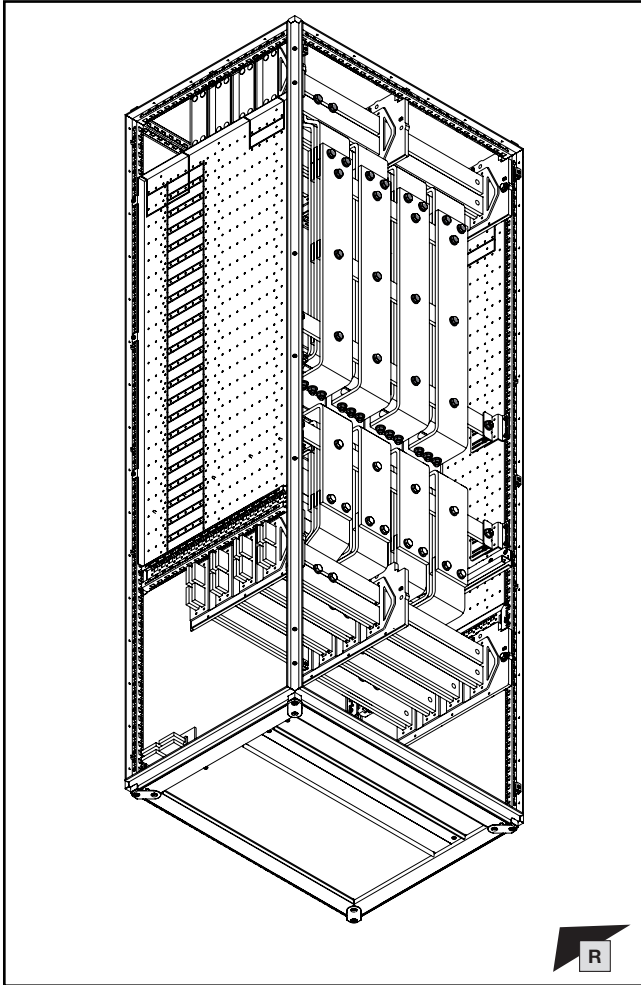

1. Montage 4-poliges HSS
1. Fitting the 4-pole MBS
1. Montage des JBP tétrapolaires

- 1.14 Montage des offenen Leistungsschalters – Anziehen der Schrauben
- 1.14 Fitting the circuit-breaker – Tightening the screws
- 1.14 Montage du disjoncteur de puissance – serrage des vis



 **Hinweis / Note / Remarque (A)**  
**Drehmoment Befestigungsschrauben gemäß Hersteller des ACB!**  
**Selection of fastening screws in accordance with the manufacturer of the ACB!**  
**Choix des vis de fixation en fonction de la marque du disjoncteur de puissance !**

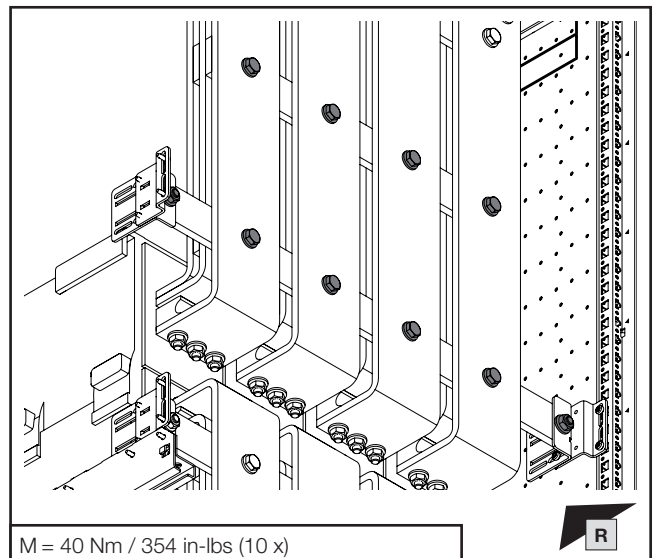
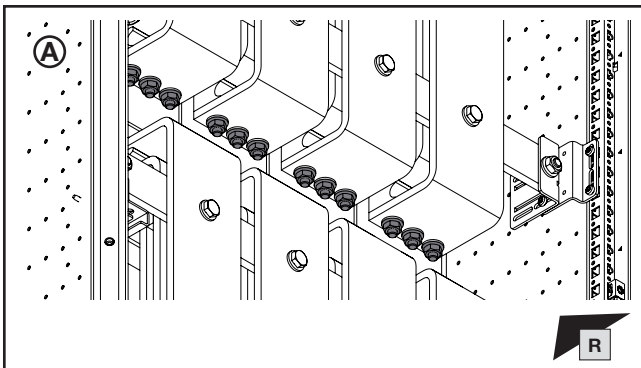

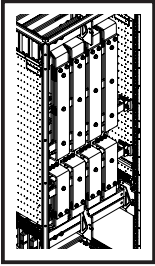

SW16/  
SW17



1. Montage 4-poliges HSS
1. Fitting the 4-pole MBS
1. Montage des JBP tétrapolaires

- 1.14 Montage des offenen Leistungsschalters – Anziehen der Schrauben
- 1.14 Fitting the circuit-breaker – Tightening the screws
- 1.14 Montage du disjoncteur de puissance – serrage des vis

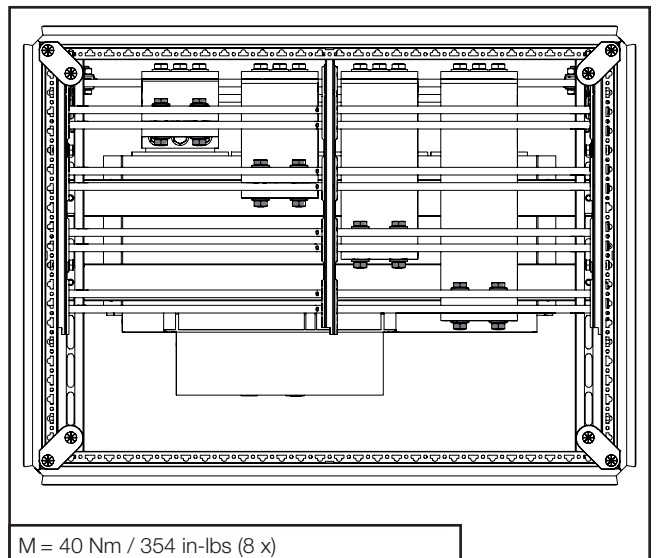
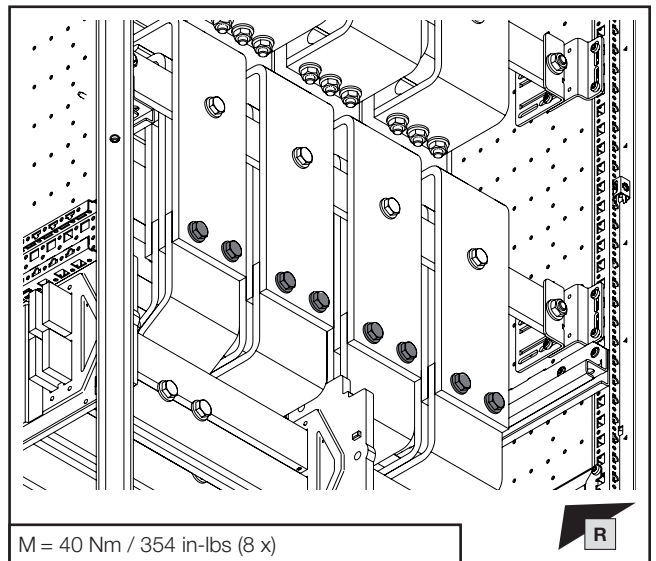
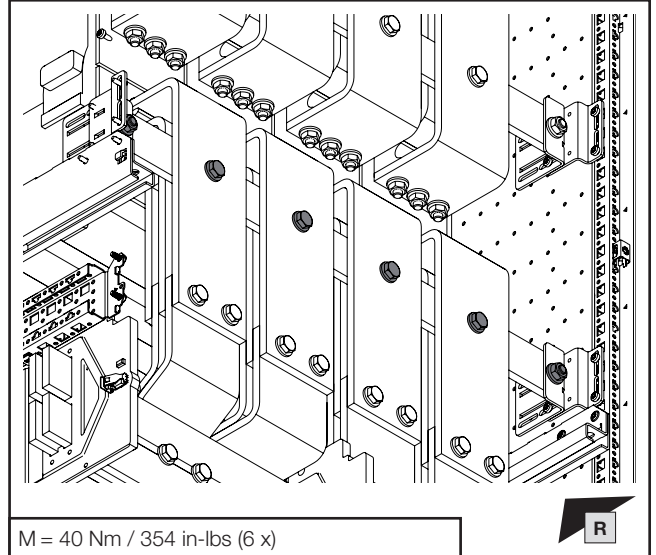
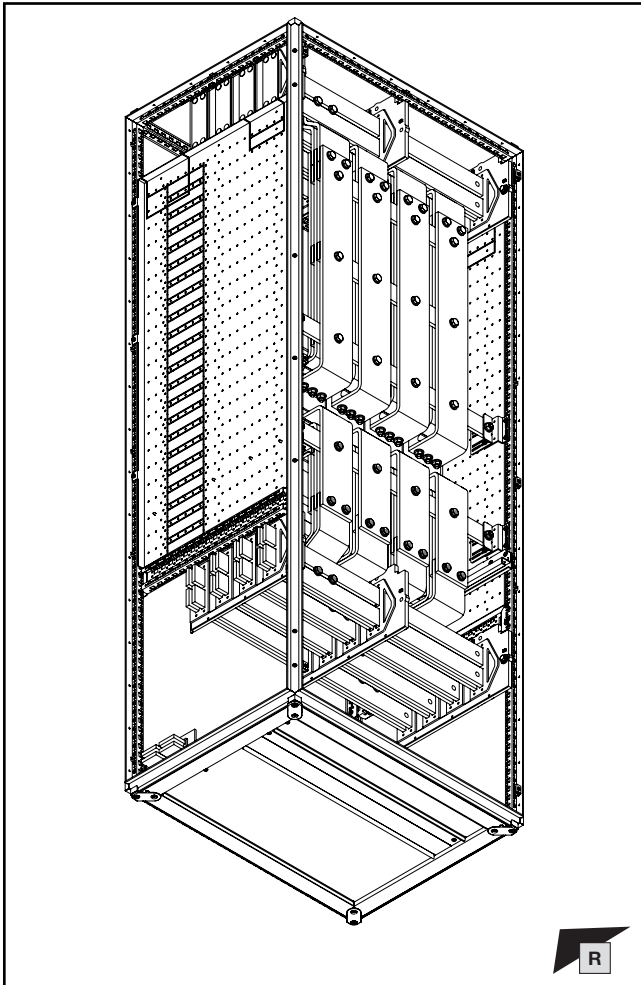

Hinweis / Note / Remarque (A)

Drehmoment Befestigungsschrauben gemäß Hersteller des ACB!

Selection of fastening screws in accordance with the manufacturer of the ACB!

Choix des vis de fixation en fonction de la marque du disjoncteur de puissance !

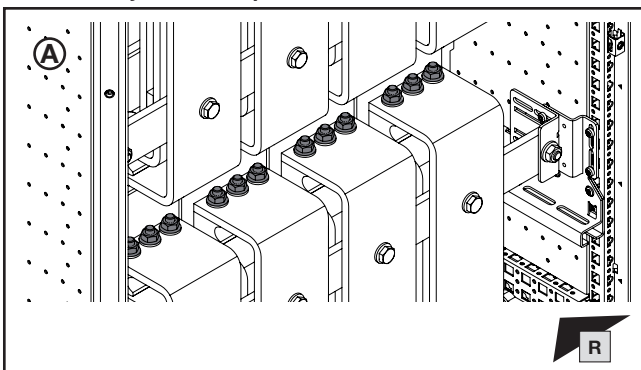

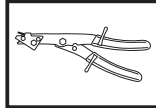
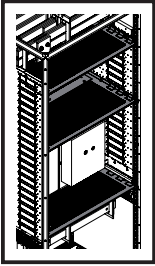

- 1. Montage 4-poliges HSS
- 1. Fitting the 4-pole MBS
- 1. Montage des JBP tétrapolaires

- 1.15 Montage Funktionsraumteiler
- 1.15 Fitting the compartment divider
- 1.15 Montage de la cloison fonctionnelle

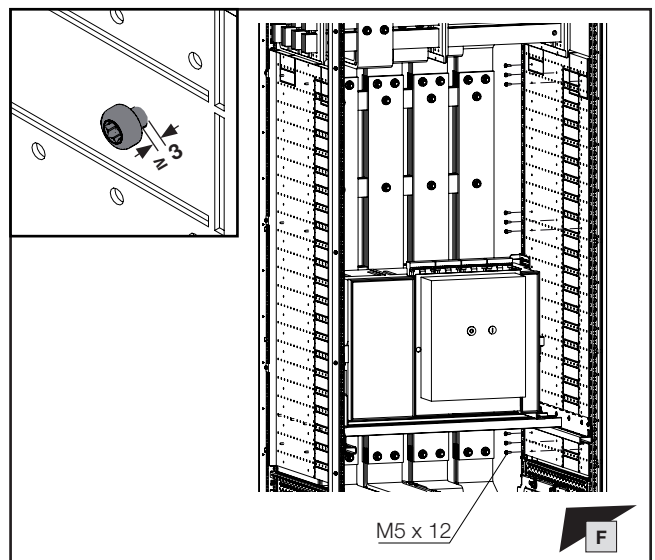
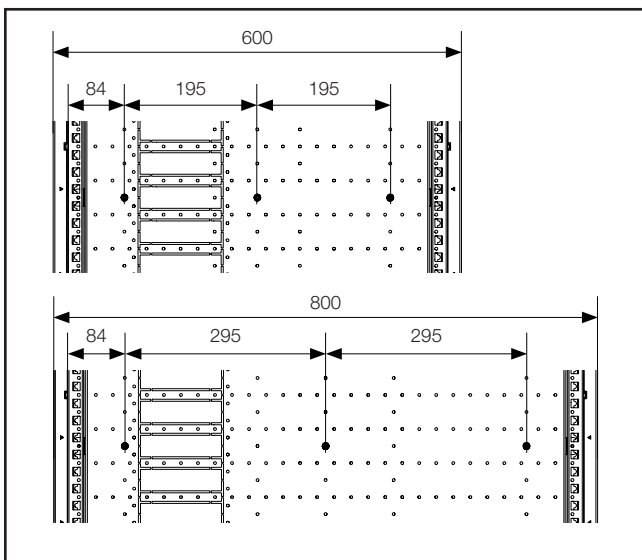
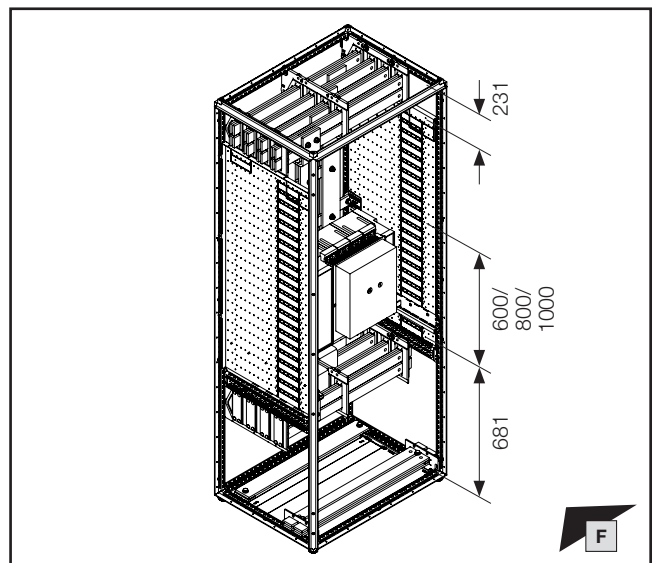
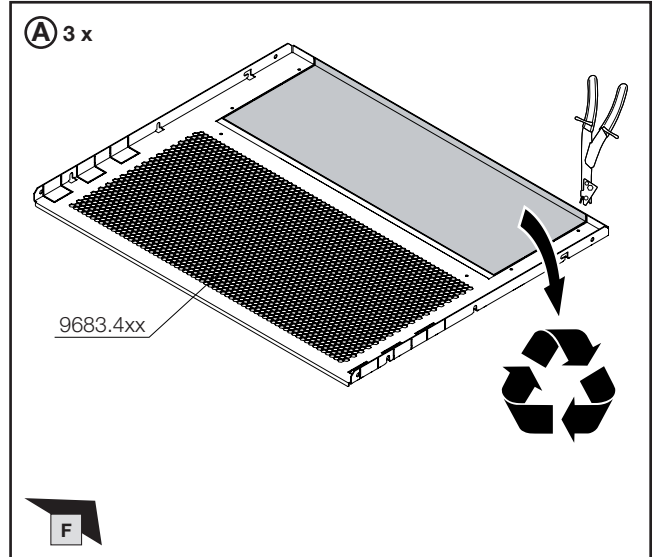
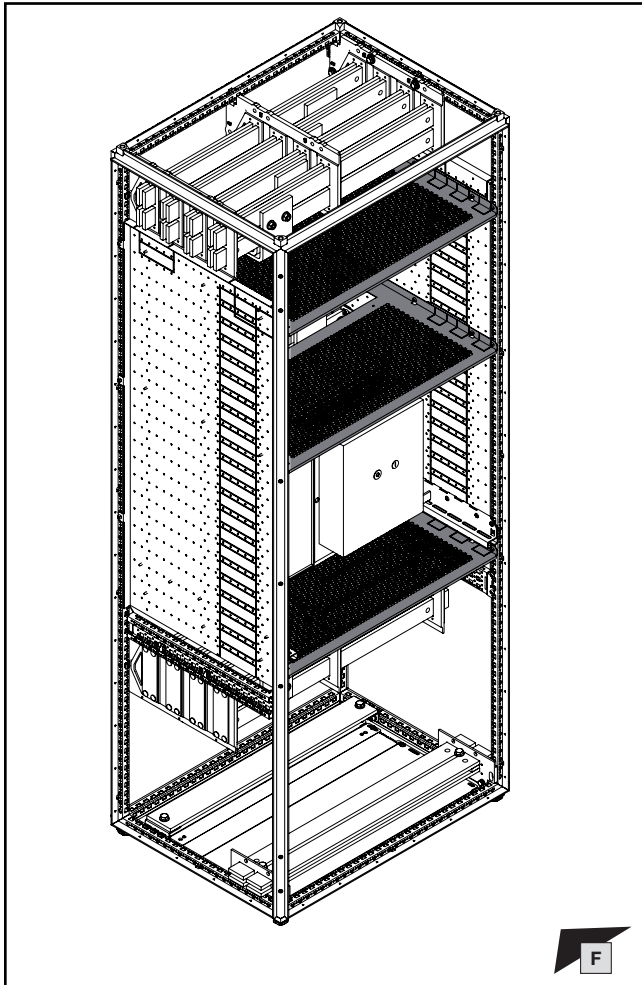

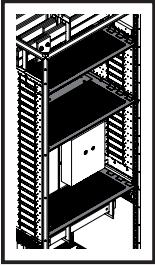

TX30



DE EN FR



- 1. Montage 4-poliges HSS
- 1. Fitting the 4-pole MBS
- 1. Montage des JBP tétrapolaires

- 1.15 Montage Funktionsraumteiler
- 1.15 Fitting the compartment divider
- 1.15 Montage de la cloison fonctionnelle

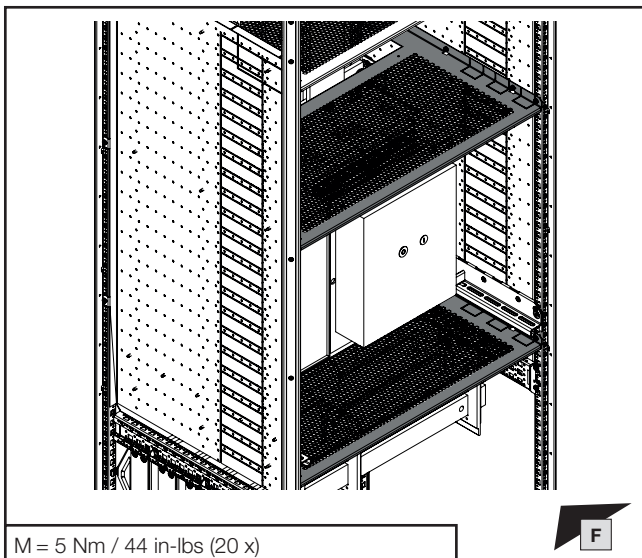
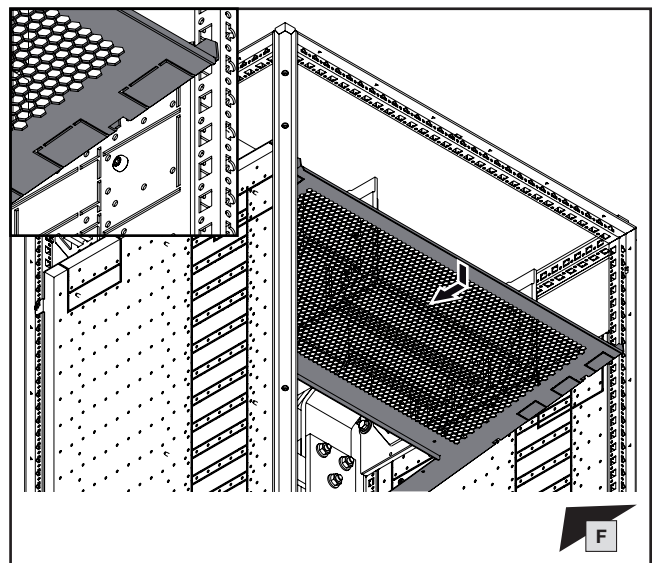
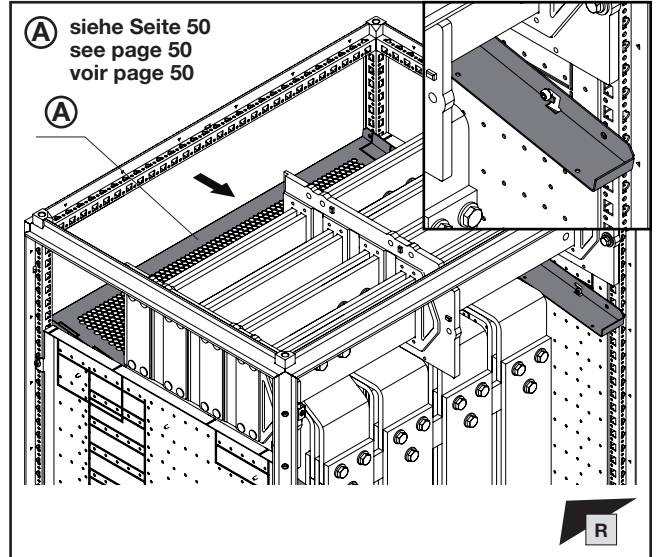
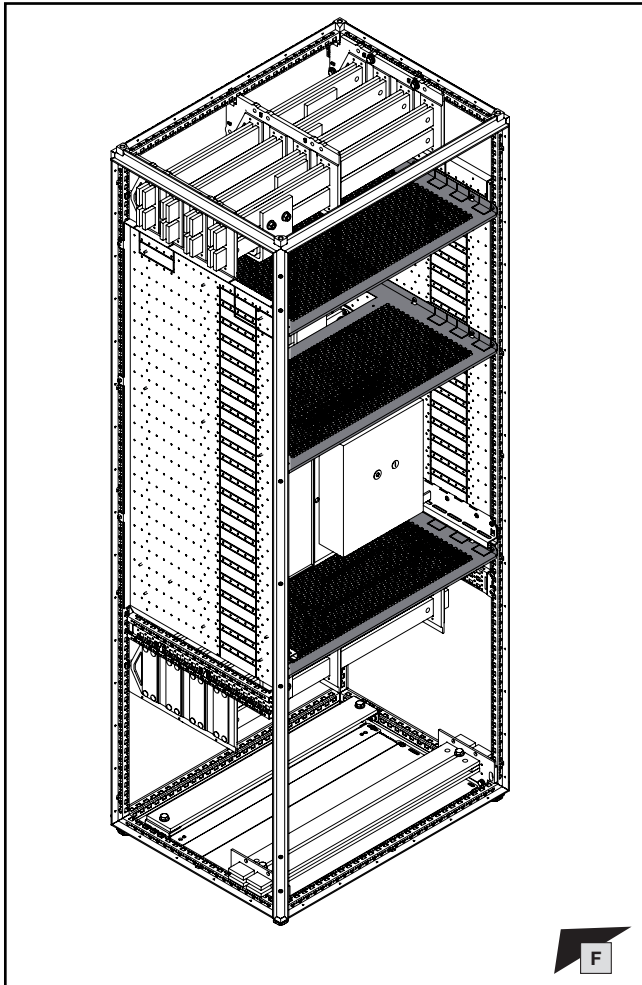

M = 5 Nm / 44 in-lbs (20 x)

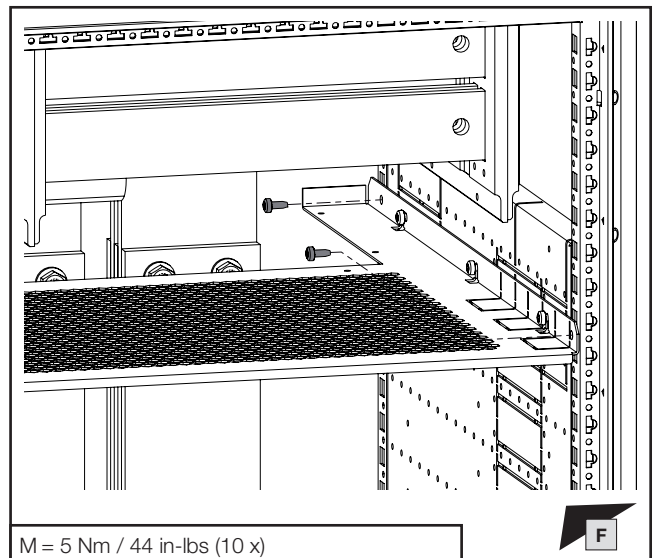

M = 5 Nm / 44 in-lbs (10 x)



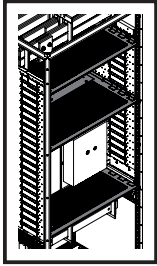

1. Montage 4-poliges HSS  
 1. Fitting the 4-pole MBS  
 1. Montage des JBP tétrapolaires

1.15 Montage Funktionsraumteiler  
 1.15 Fitting the compartment divider  
 1.15 Montage de la cloison fonctionnelle

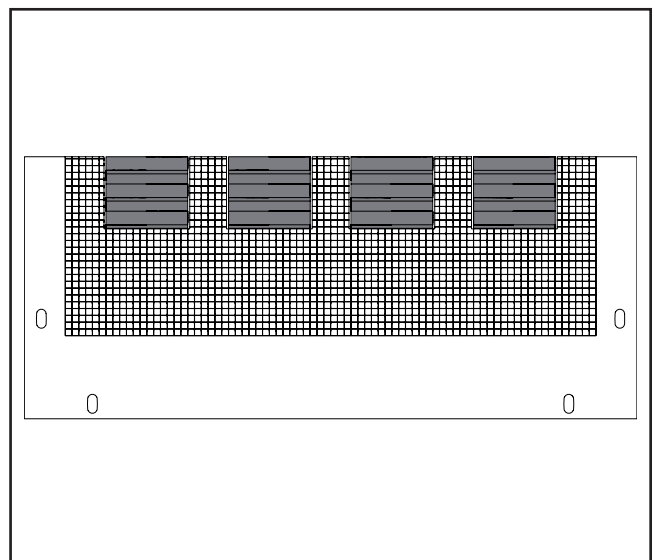
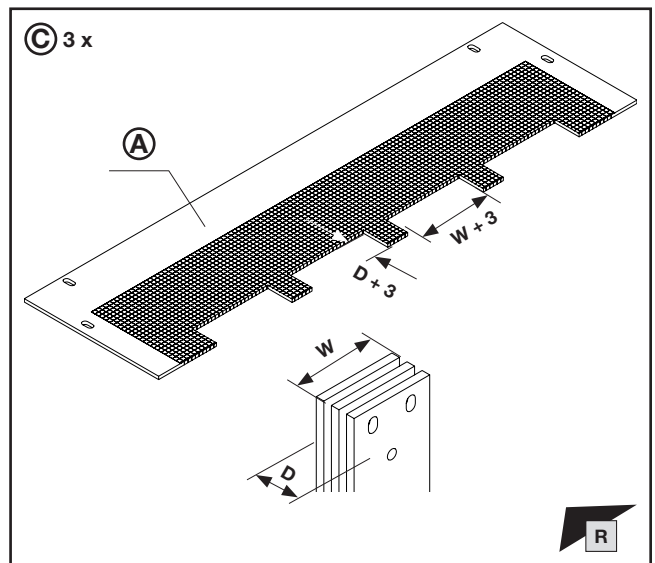
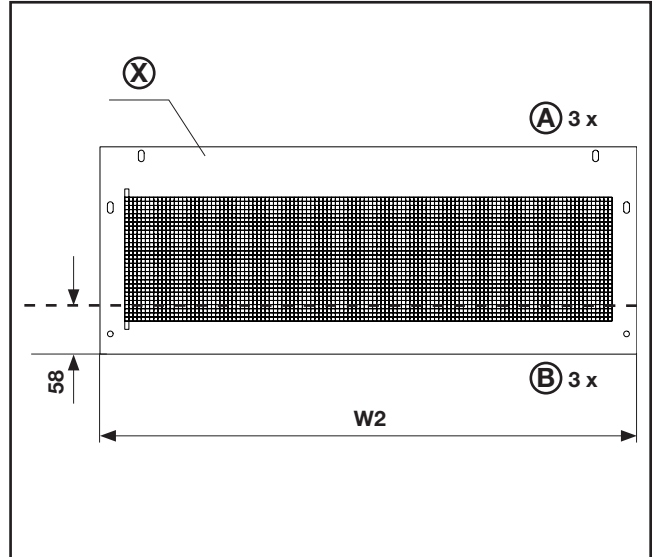
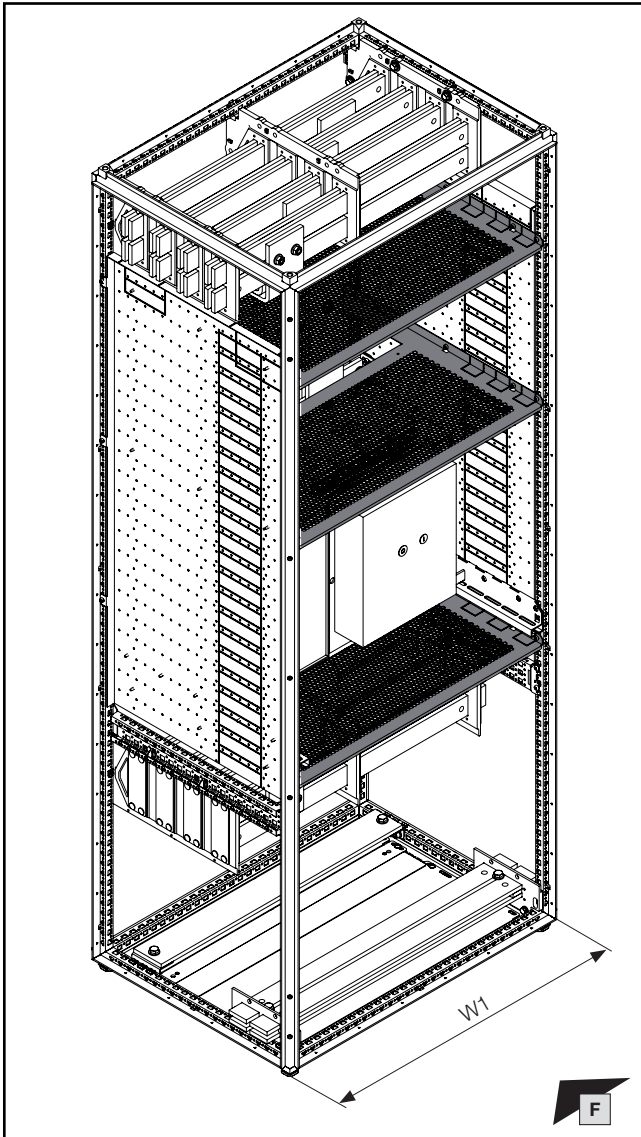

Schrankbreite W1 mm Enclosure width W1 mm Largeur d'armoire W1 mm	Breite W2 mm Width W2 mm Largeur W2 mm	(X) Best.-Nr. Model No. Référence
400	250	9683.504
600	450	9683.506
800	650	9683.508
1000	850	9683.500

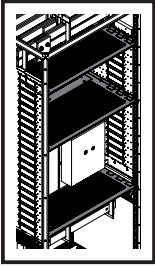

**TX30**



DE EN FR



- 1. Montage 4-poliges HSS
- 1. Fitting the 4-pole MBS
- 1. Montage des JBP tétrapolaires

- 1.15 Montage Funktionsraumteiler
- 1.15 Fitting the compartment divider
- 1.15 Montage de la cloison fonctionnelle

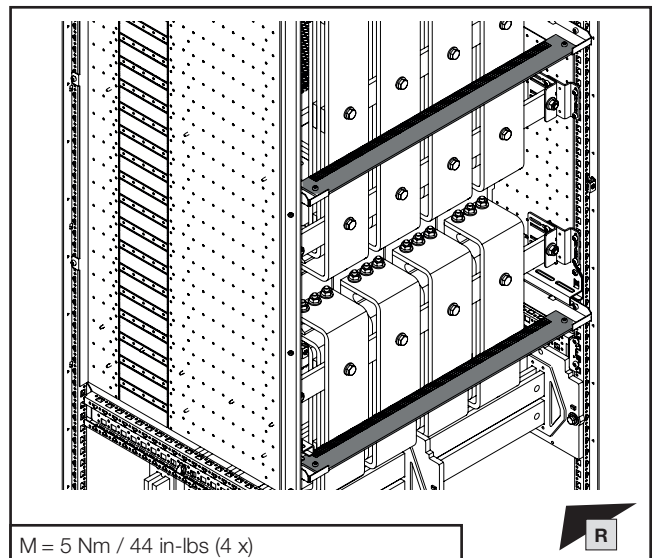
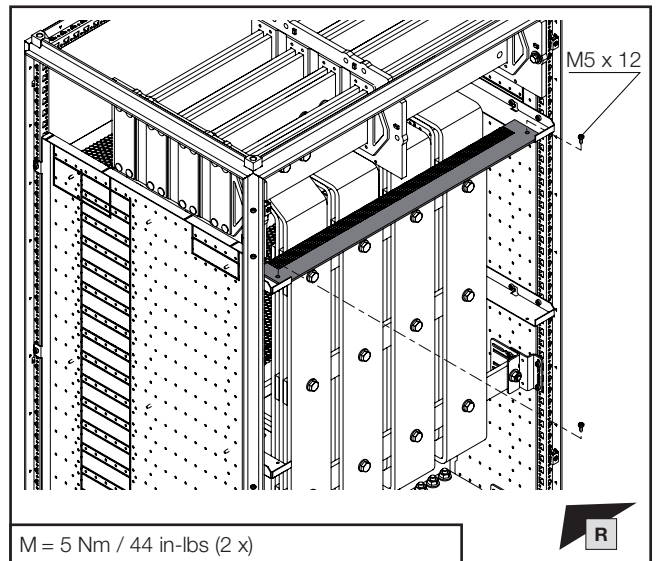
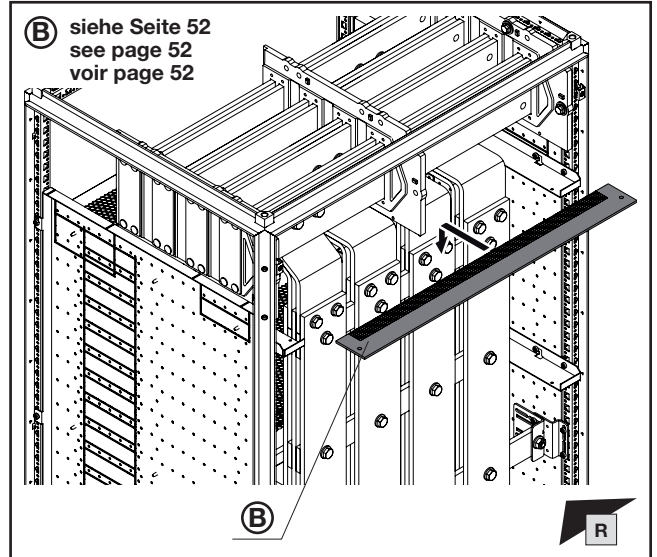
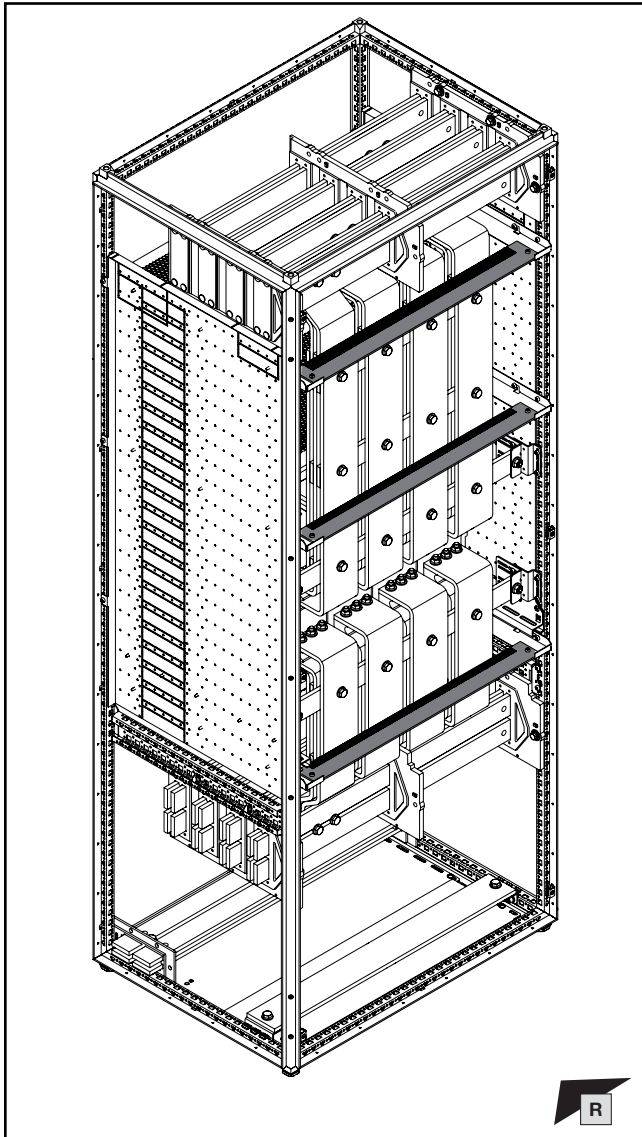

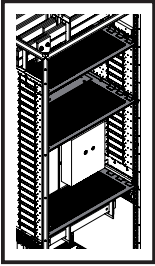

TX30



DE EN FR



1. Montage 4-poliges HSS
1. Fitting the 4-pole MBS
1. Montage des JBP tétrapolaires

- 1.15 Montage Funktionsraumteiler
- 1.15 Fitting the compartment divider
- 1.15 Montage de la cloison fonctionnelle

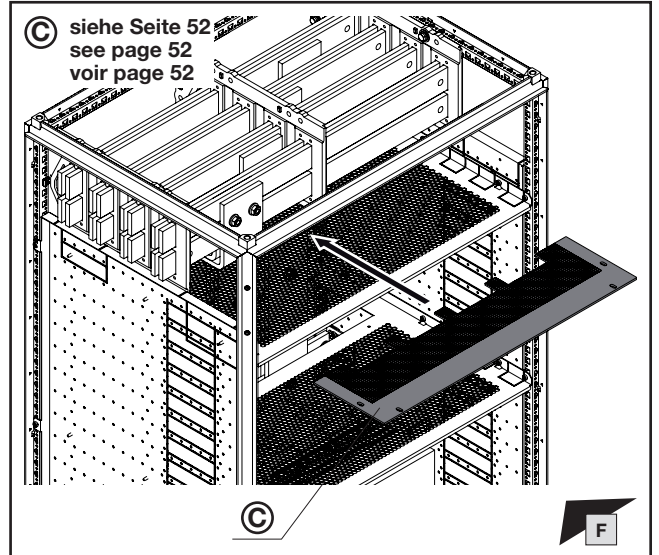
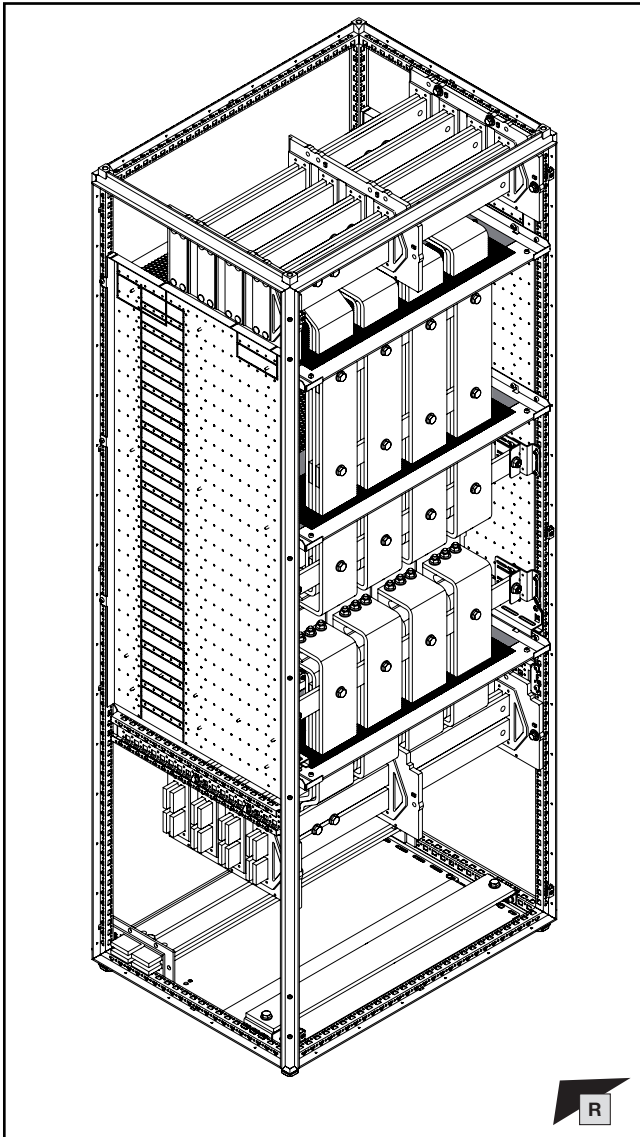

© siehe Seite 52  
see page 52  
voir page 52

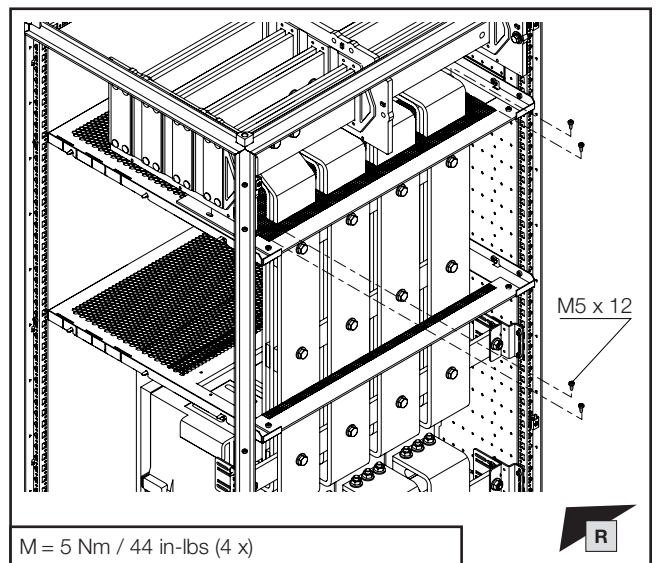

M = 5 Nm / 44 in-lbs (4 x)

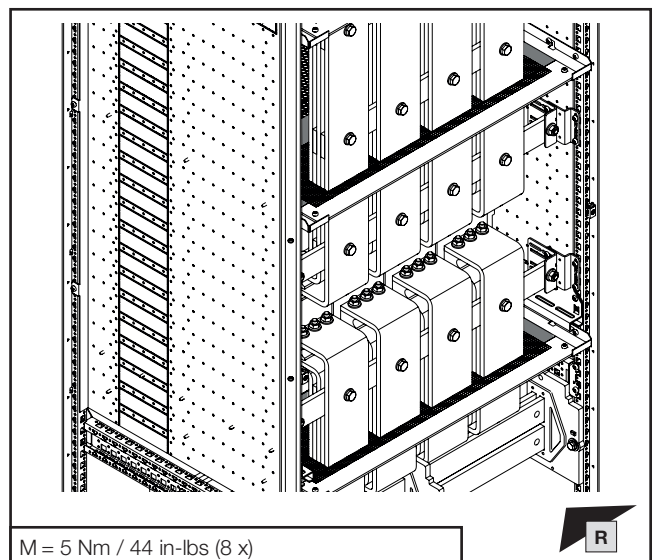

M = 5 Nm / 44 in-lbs (8 x)

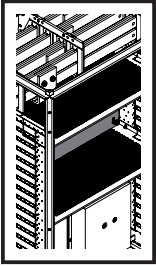

SW13



DE EN FR



- 1. Montage 4-poliges HSS
- 1. Fitting the 4-pole MBS
- 1. Montage des JBP tétrapolaires

- 1.16 Montage der Teilmontageplatte
- 1.16 Fitting the partial mounting plate
- 1.16 Montage de la plaque de montage partielle

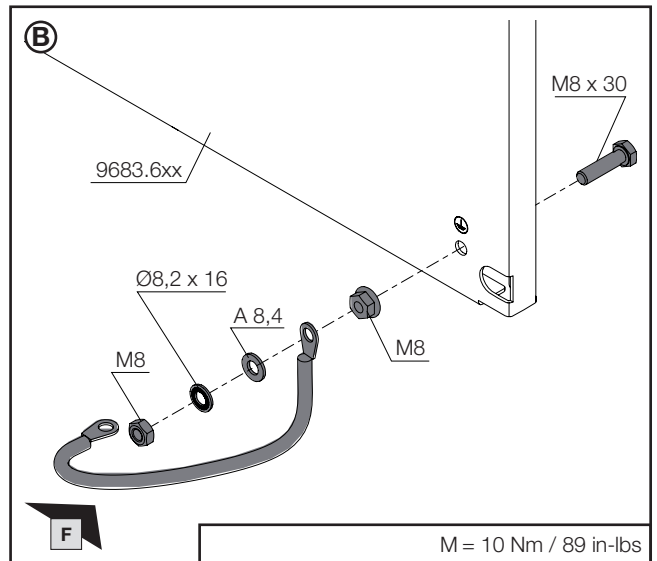
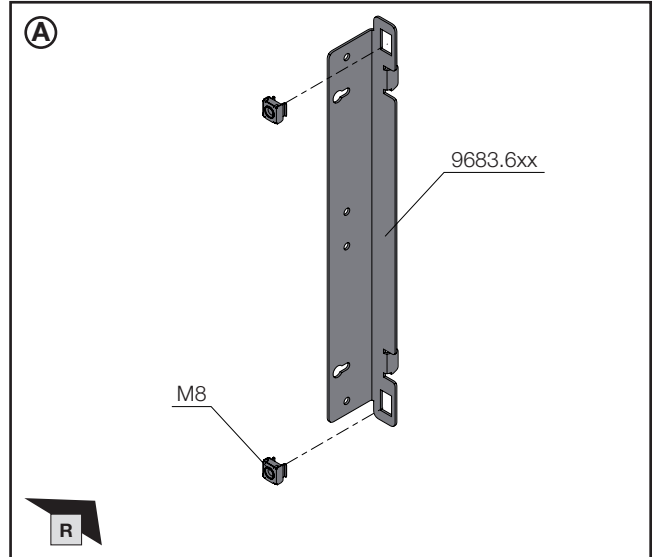
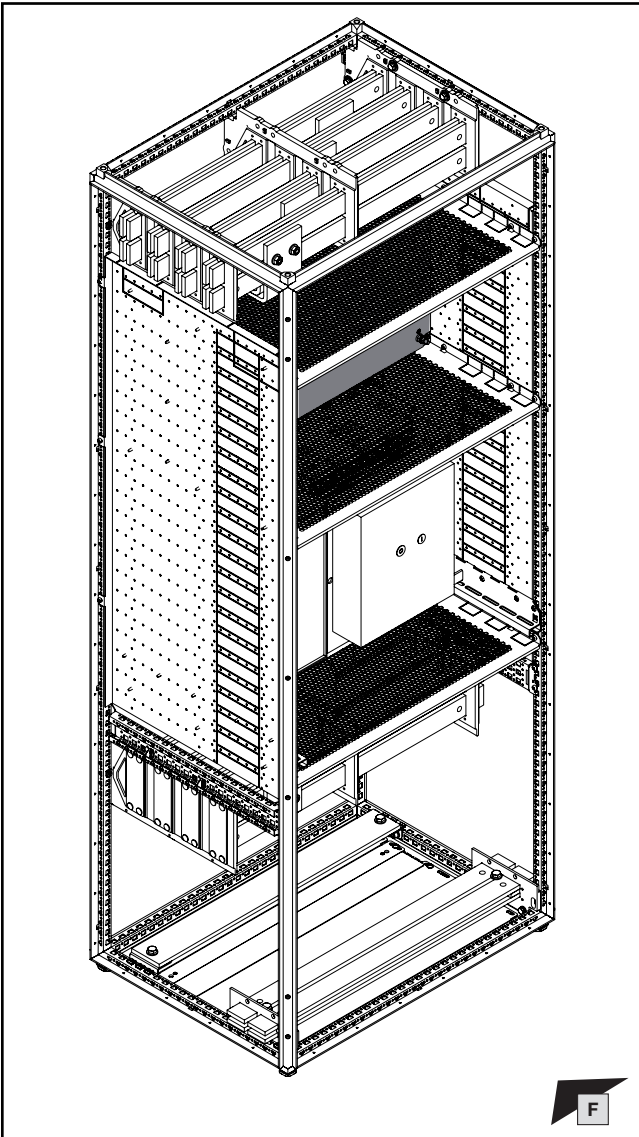

Schranksystem VX25 – Technische Dokumentation – Schutzleiteranschluss, Strombelastbarkeit

VX25 Enclosure System – Technical documentation – PE conductor connection, current carrying capacity

Armoires électriques VX25 – Manuel technique – Raccordement de mise à la terre et intensités maximales admissibles

DE EN FR

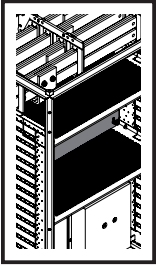

1. Montage 4-poliges HSS
1. Fitting the 4-pole MBS
1. Montage des JBP tétrapolaires

- 1.16 Montage der Teilmontageplatte
- 1.16 Fitting the partial mounting plate
- 1.16 Montage de la plaque de montage partielle

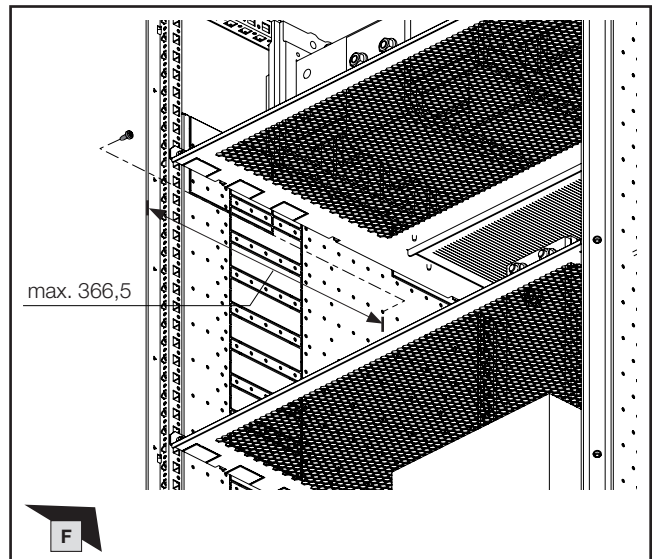
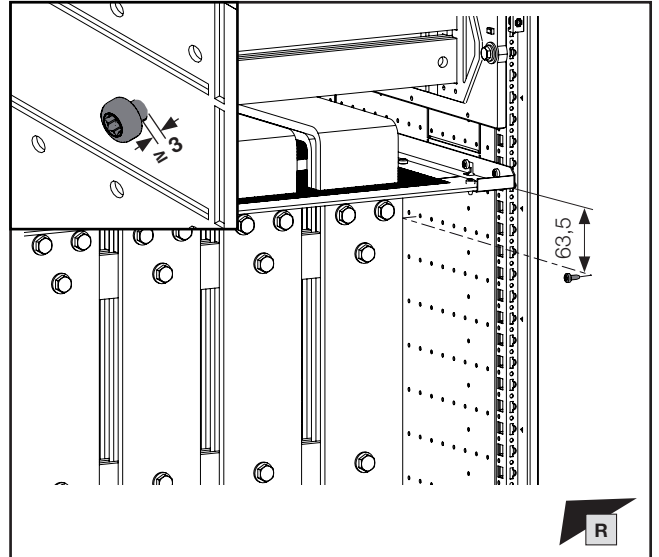
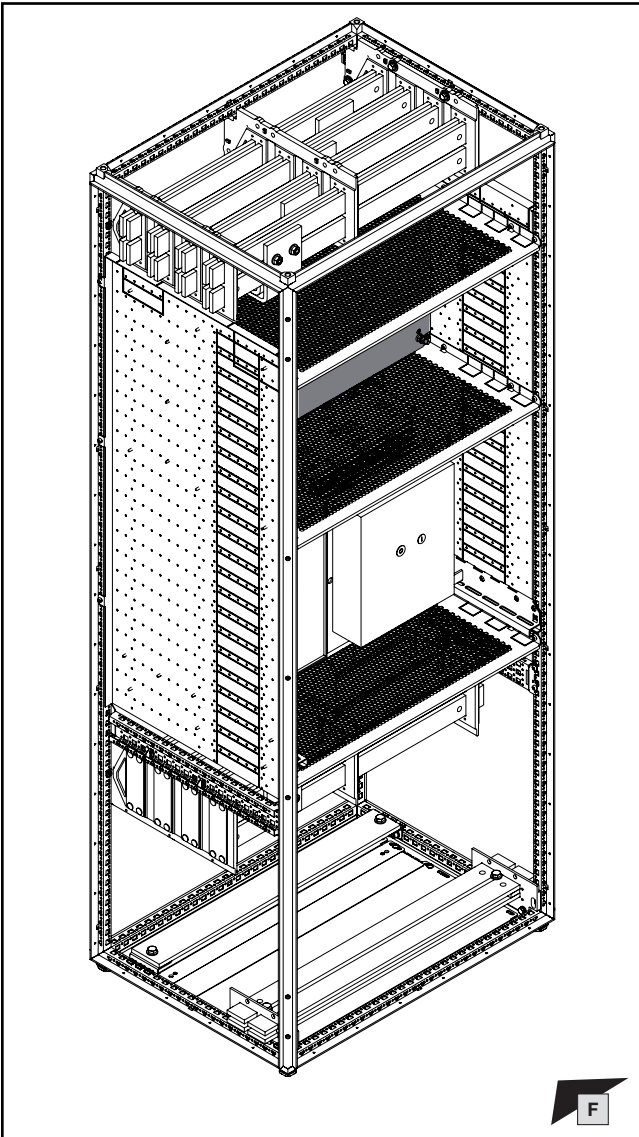

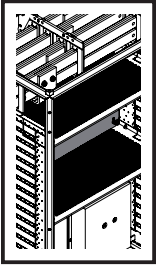

**TX30**



DE EN FR



- 1. Montage 4-poliges HSS
- 1. Fitting the 4-pole MBS
- 1. Montage des JBP tétrapolaires

- 1.16 Montage der Teilmontageplatte
- 1.16 Fitting the partial mounting plate
- 1.16 Montage de la plaque de montage partielle

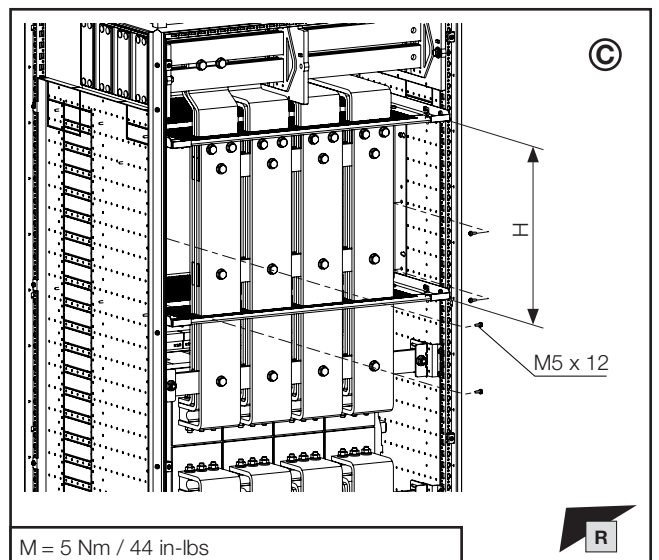
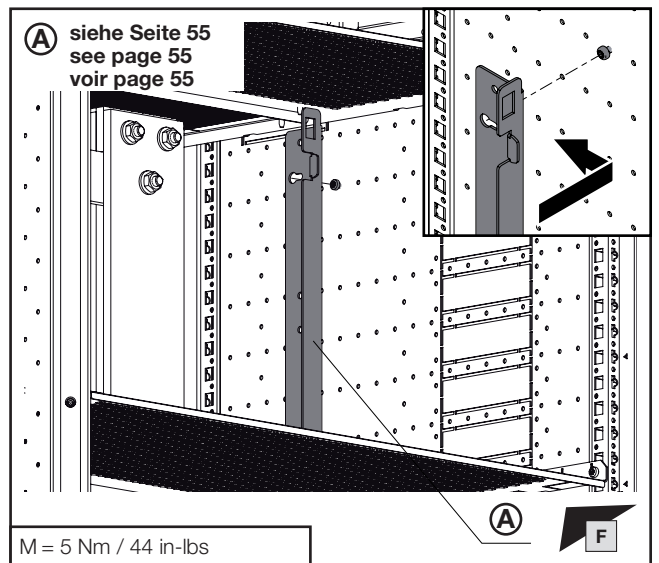
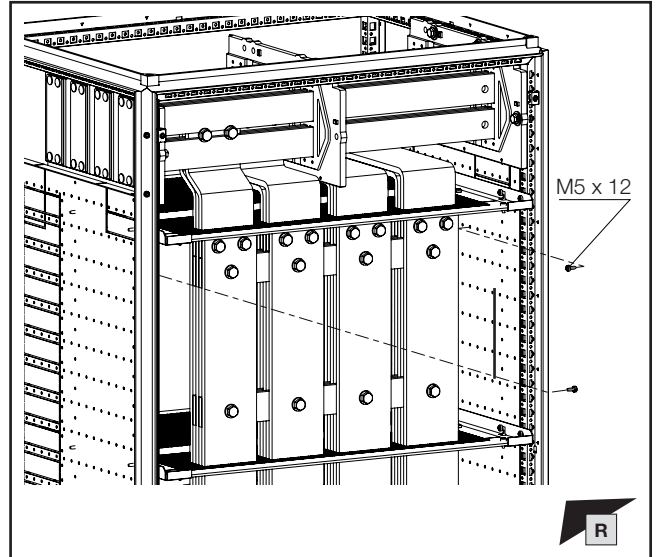
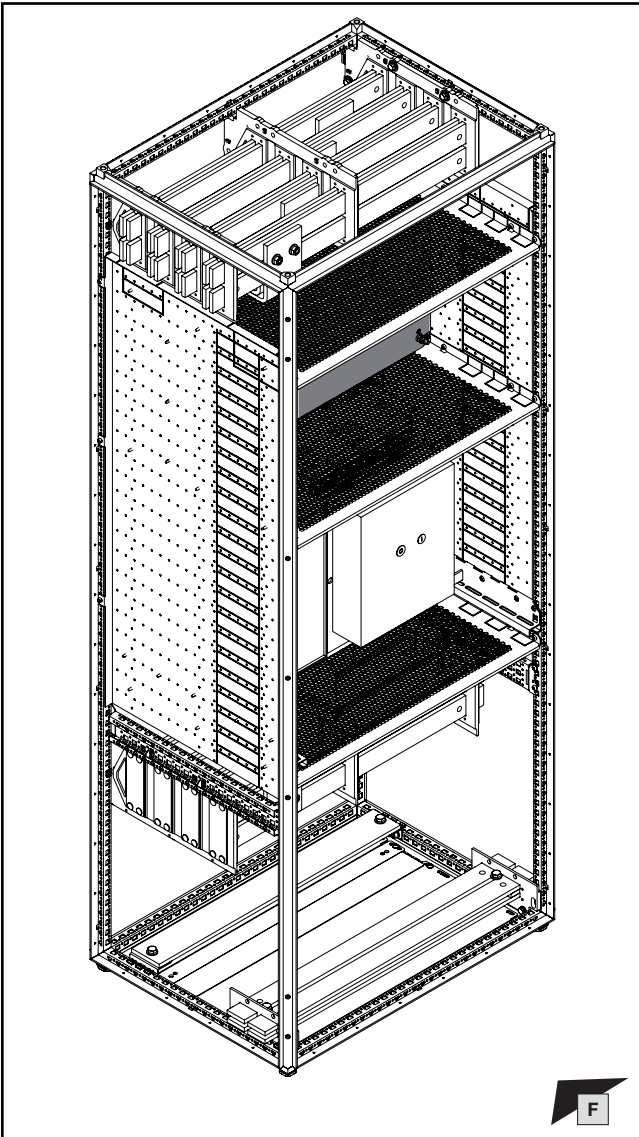

H mm	© Anzahl Schrauben M5 x 12 Number of screws M5 x 12 Nombre de vis M5 x 12
200	2 x 3
300	2 x 3
400	2 x 3
600	2 x 3

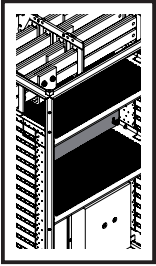

TX30



DE EN FR



- 1. Montage 4-poliges HSS
- 1. Fitting the 4-pole MBS
- 1. Montage des JBP tétrapolaires

- 1.16 Montage der Teilmontageplatte
- 1.16 Fitting the partial mounting plate
- 1.16 Montage de la plaque de montage partielle

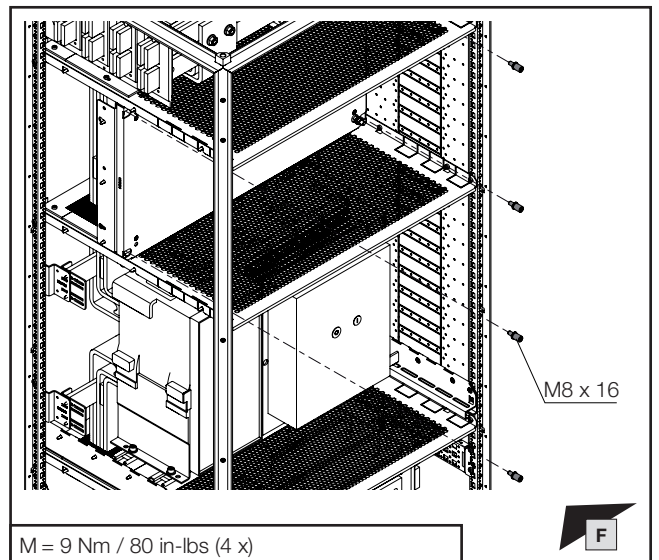
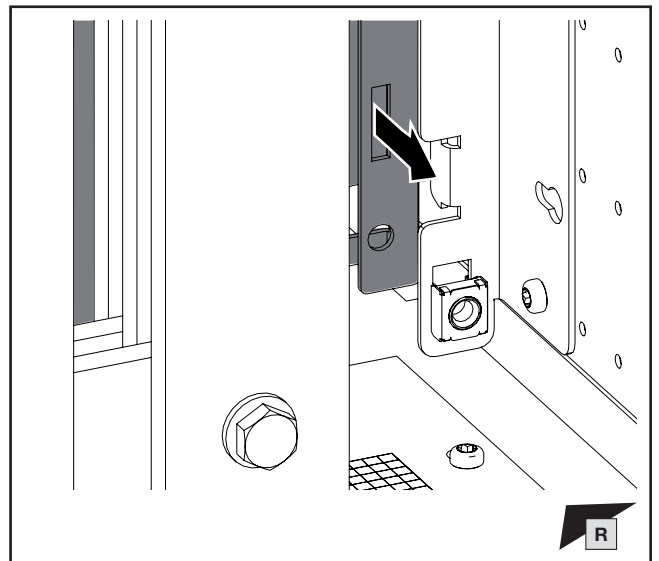
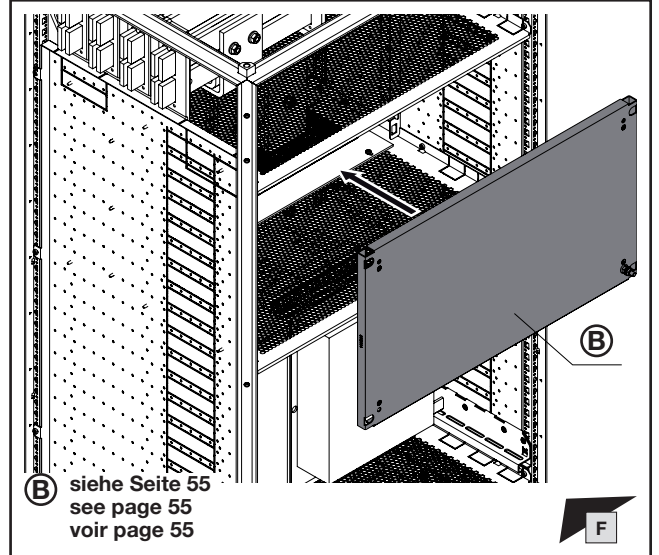
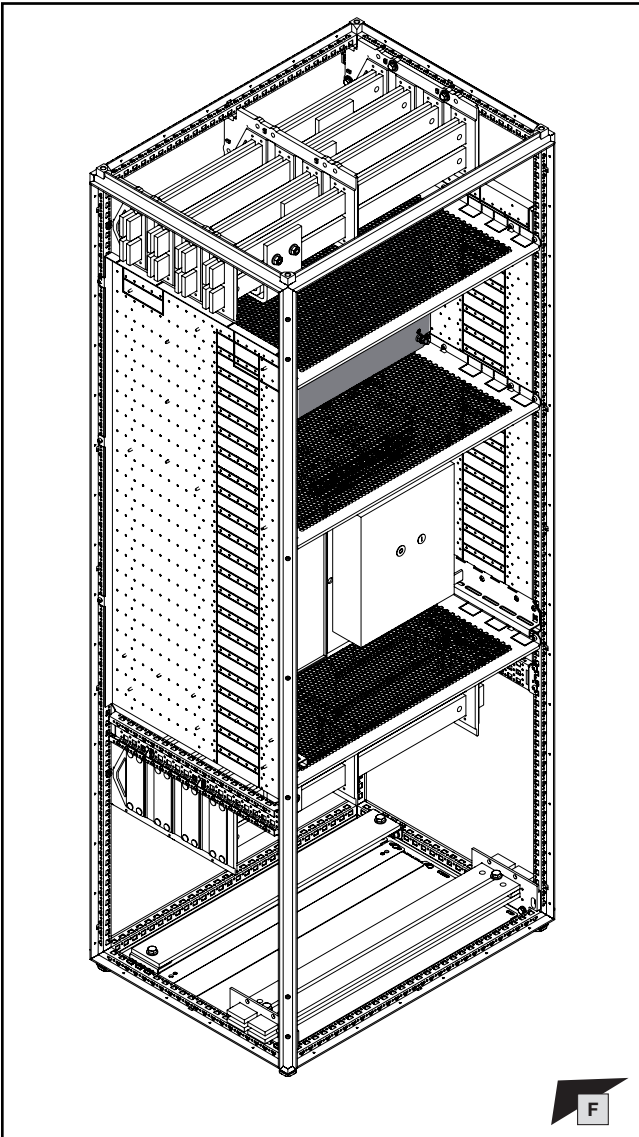

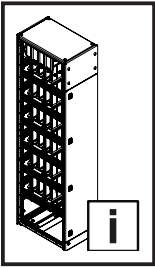

2. Montage Hochführungsfeld  
 2. Fitting the riser section  
 2. Montage de zone d'installation verticale

- 2.1 Hochführungsfeld 600 mm tief
- 2.1 Riser section 600 mm deep
- 2.1 Zone d'installation verticale d'une profondeur de 600 mm

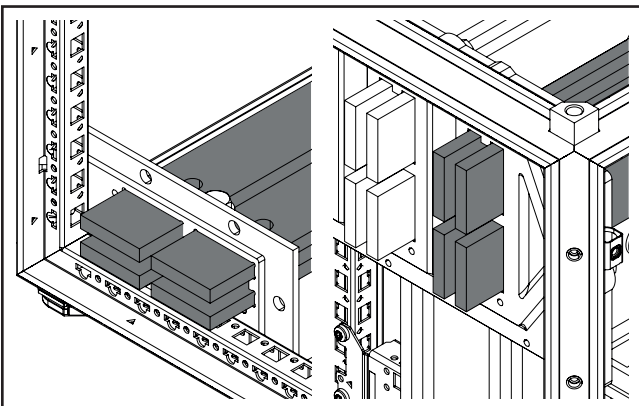
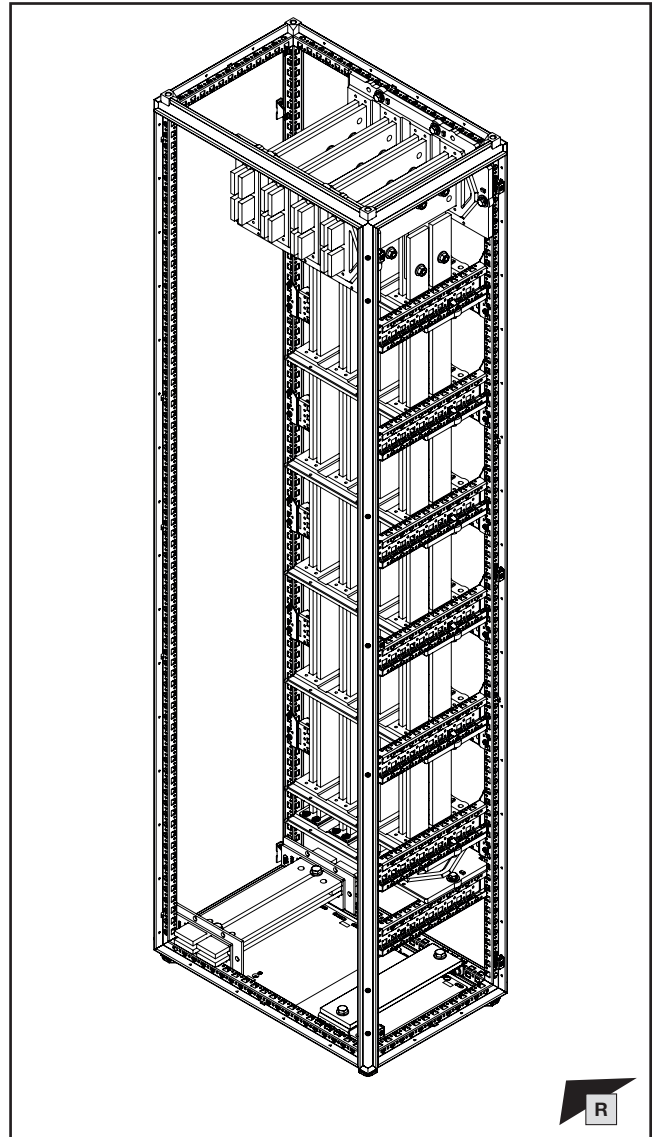
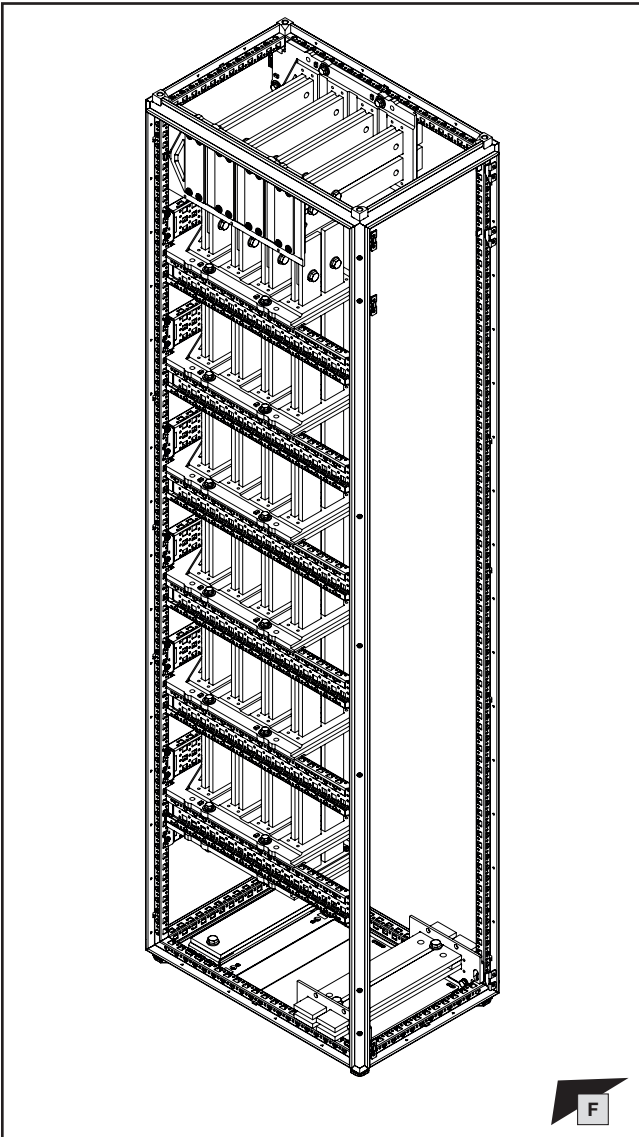

Hinweis / Note / Remarque

Neutralleiter N für 3-polige HSS nach Wahl des Anlagenbetreibers im Bodenbereich oder im Dachbereich (siehe Kapitel 5). Montage beider Varianten wird im Kapitel 2 parallel gezeigt.

Neutral conductor N for 3-pole main busbar systems as chosen by the plant operator in the floor area or in the roof area (see chapter 5). The assembly of both variants is shown in parallel in chapter 2.

Neutre N pour jeux de barres principaux tripolaires dans la base ou sous le toit, selon le choix de l'exploitant de l'installation (voir chapitre 5). Le montage des deux variantes est décrit au chapitre 2.

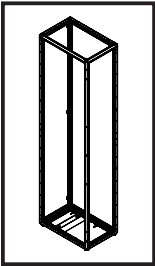

**2. Montage Hochführungsfeld**  
**2. Fitting the riser section**  
**2. Montage de zone d'installation verticale**

- 2.2 Vorbereitung Modulschrank
- 2.2 Preparing the modular enclosure
- 2.2 Préparation de l'armoire modulaire

Montageanleitung VX25 Ri4Power – Schalt- und Energieverteilanlagen-System  
 Assembly instructions VX25 Ri4Power – Switchgear and power distribution system  
 Notice de montage VX25 Ri4Power – Distribution de courant

**DE/EN/FR**



**Hinweis / Note / Remarque**  
 Vorbereitende Arbeiten: siehe o. g. Anleitung, Kapitel „Demontage Flachteile“ und „Vorbereitung Montage Frontblenden“.  
 Preparatory work: see above mentioned assembly instructions, chapter "Dismantling panels" and "Preparation of mounting front trim panels".  
 Pour les travaux préliminaires, voir les chapitres « Démontage des pièces plates » et « Préparation du montage des faces avant » de la notice de montage ci-dessus.



**Hinweis / Note / Remarque**  
 Für Schutz Eigenschaft Störlichtbogenklasse A/B Montagereihenfolge in den entsprechenden Kapiteln der o. g. Anleitung beachten.  
 For arcing class A/B protection, please follow the assembly sequence as set out in the relevant chapters of the aforementioned assembly instructions.  
 Pour la protection contre les arcs électriques de catégorie A/B, suivez la séquence de montage indiquée dans les chapitres correspondantes des instructions ci-dessus.

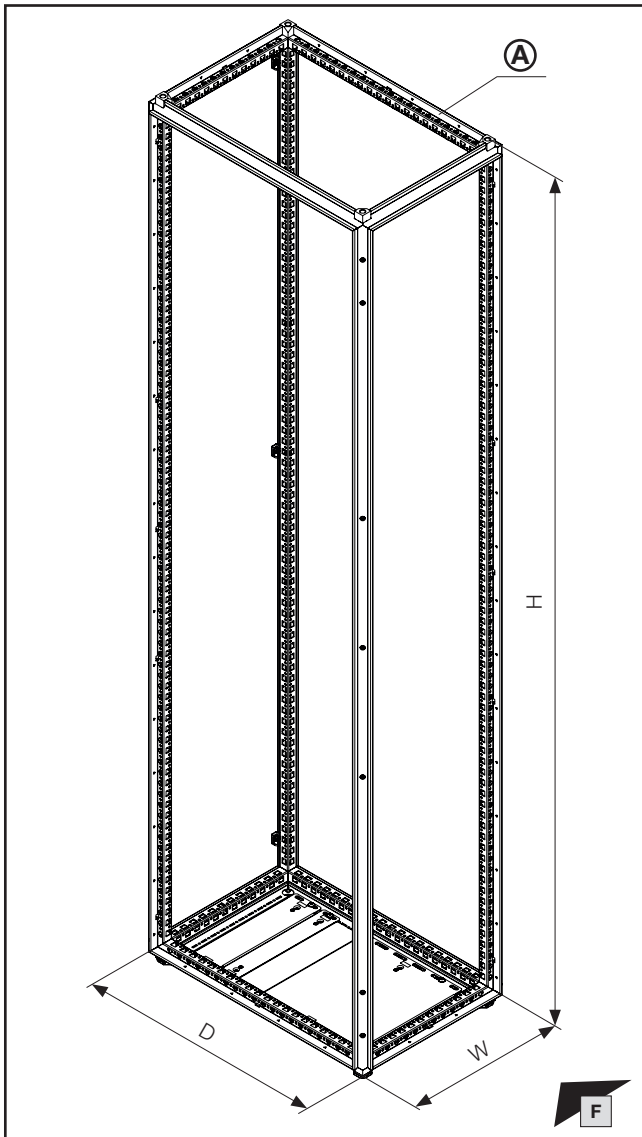

W mm	H mm	D mm	<b>A</b> Best.-Nr. Model No. Référence
400	2000	600	9680.406
400	2000	800	9680.408
400	2200	600	9680.426
400	2200	800	9680.428



**Hinweis / Note / Remarque**  
 Alternativ: Basisschrank aus Produktauswahl „Anreih-Schranksystem VX25“.  
 Option: Basic enclosure from the "baying enclosure system VX25" product selection.  
 Option : armoire électrique juxtaposable VX25 classique.



**Hinweis / Note / Remarque**  
 Die Angaben „W“ (Breite), „H“ (Höhe) und „D“ (Tiefe) der Schränke beziehen sich jeweils auf die nominalen Abmessungen der Schränke.  
 The information "W" (width), "H" (height) and "D" (depth) each refer to the nominal dimensions of the enclosures.  
 Les informations « W » (largeur), « H » (hauteur) et « D » (profondeur) se réfèrent chacune aux dimensions nominales des armoires.

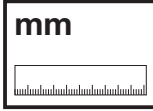
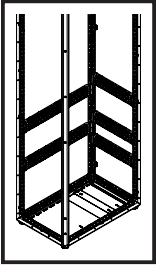

- 2. Montage Hochführungsfeld
- 2. Fitting the riser section
- 2. Montage de zone d'installation verticale

- 2.3 Montage untere System-Chassis
- 2.3 Fitting the lower punched sections with mounting flanges
- 2.3 Montage sous rails de montage

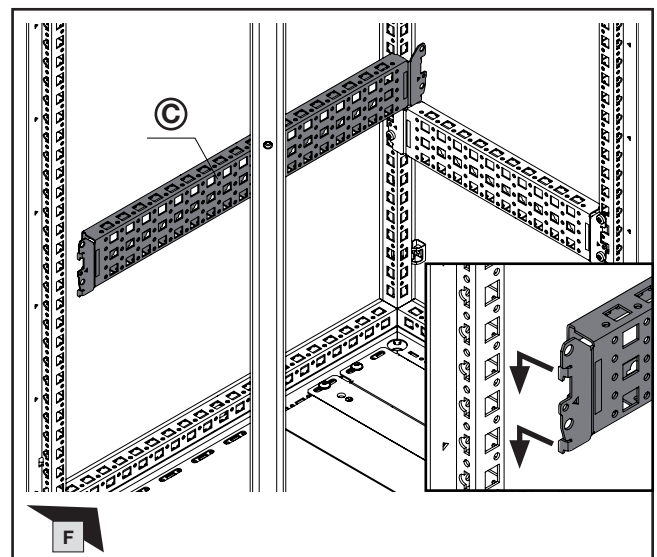
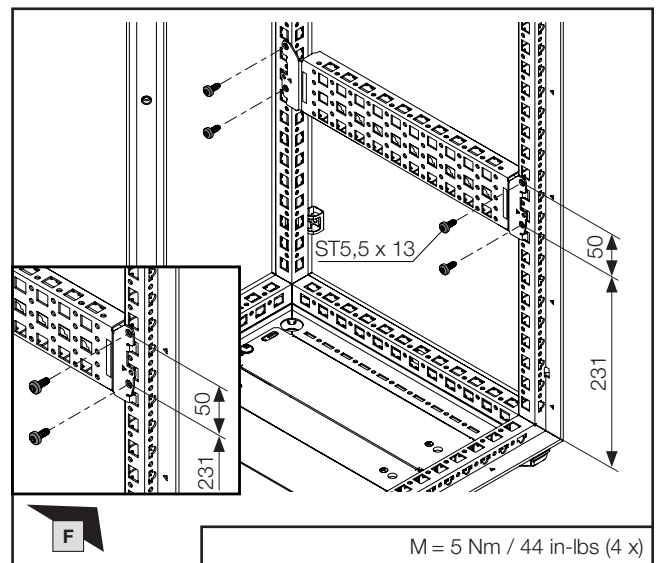
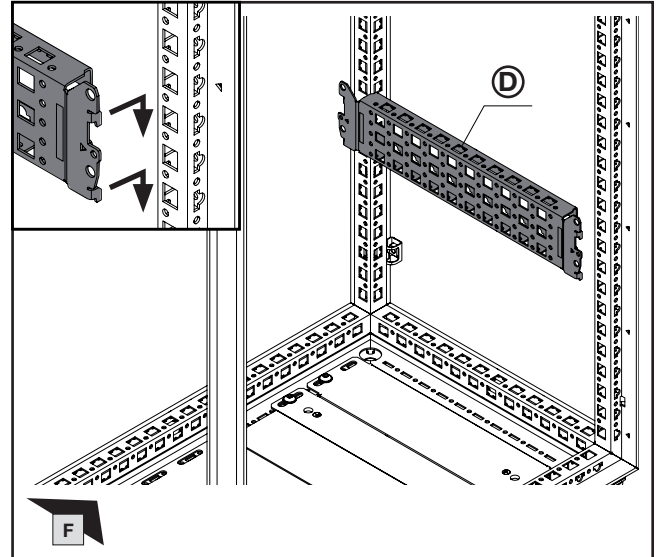
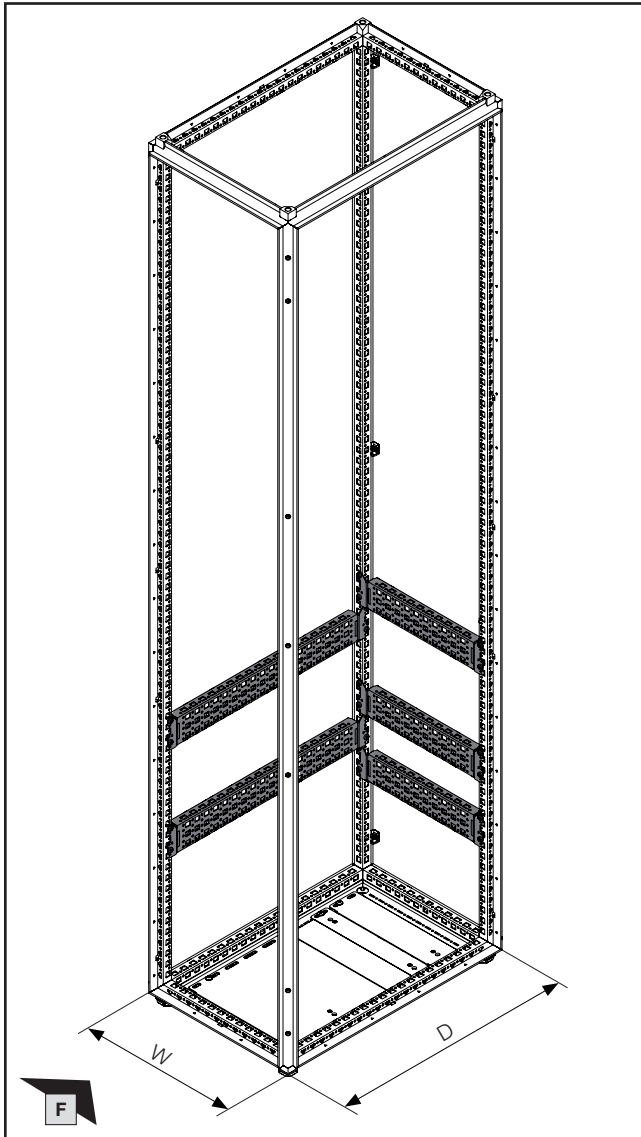

D mm	W mm	© / D Best.-Nr. Model No. Référence
x	400	8617.110
600	x	8617.130
800	x	8617.140

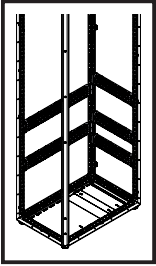

- 2. Montage Hochführungsfeld
- 2. Fitting the riser section
- 2. Montage de zone d'installation verticale

- 2.3 Montage untere System-Chassis
- 2.3 Fitting the lower punched sections with mounting flanges
- 2.3 Montage sous rails de montage

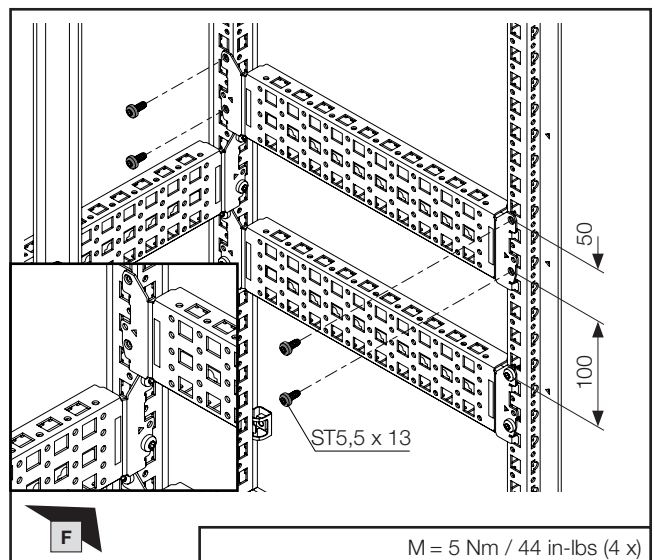
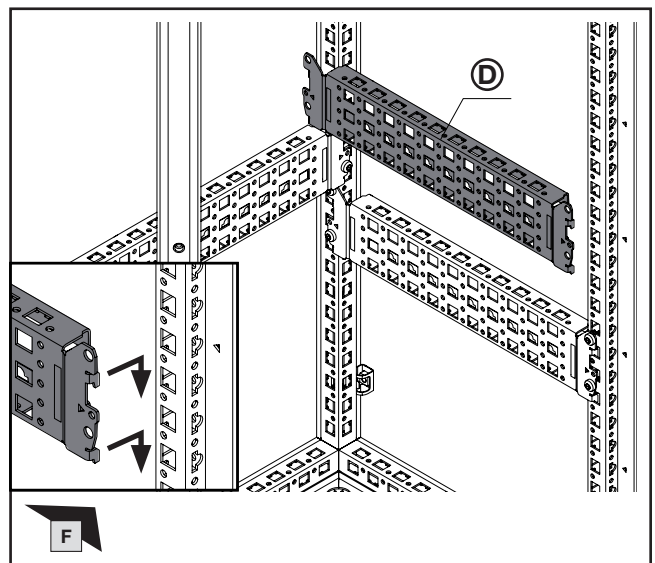
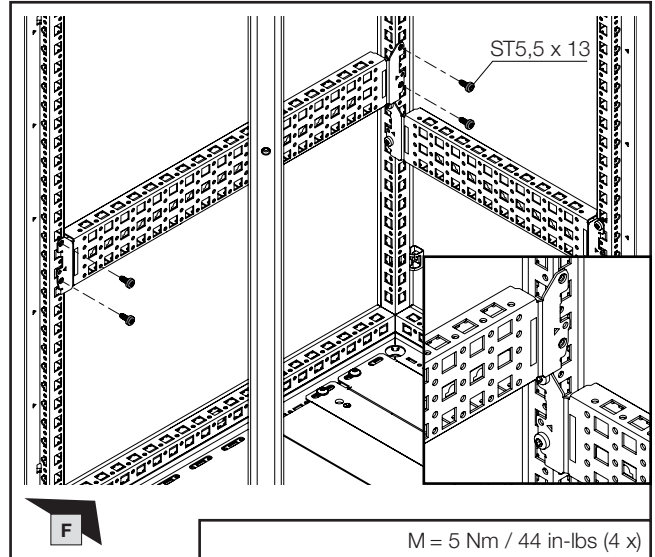
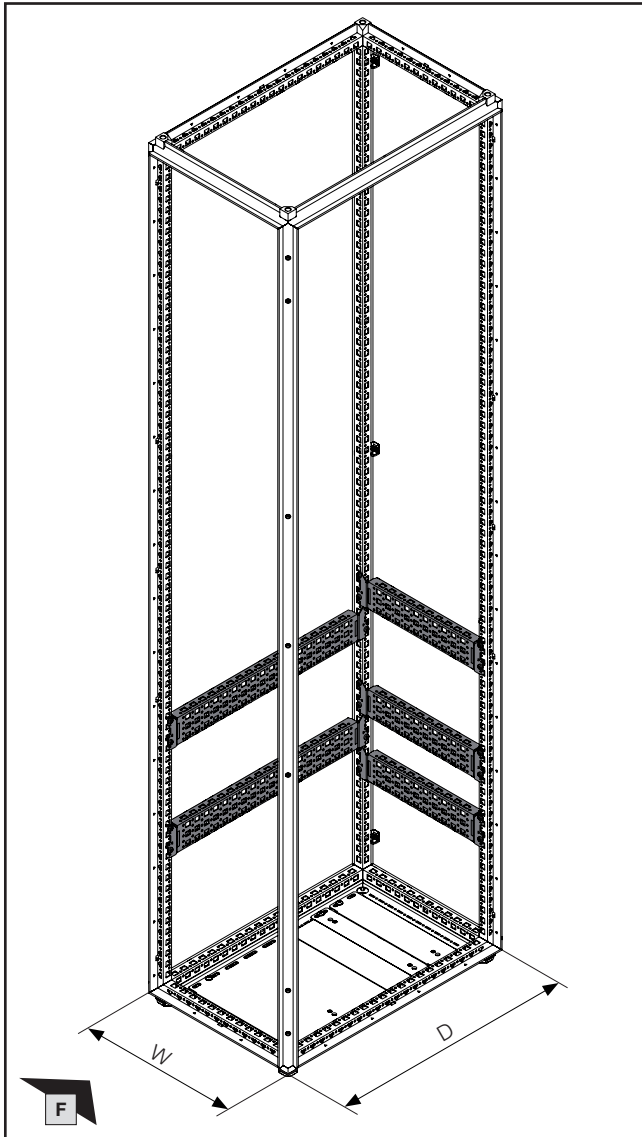

D mm	W mm	© / D Best.-Nr. Model No. Référence
x	400	8617.110
600	x	8617.130
800	x	8617.140

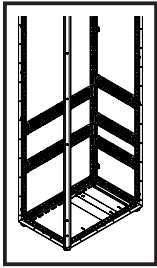

- 2. Montage Hochführungsfeld
- 2. Fitting the riser section
- 2. Montage de zone d'installation verticale

- 2.3 Montage untere System-Chassis
- 2.3 Fitting the lower punched sections with mounting flanges
- 2.3 Montage sous rails de montage

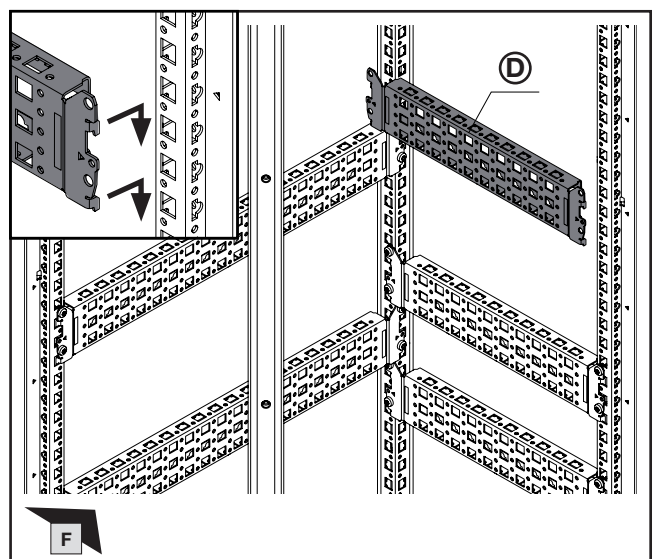
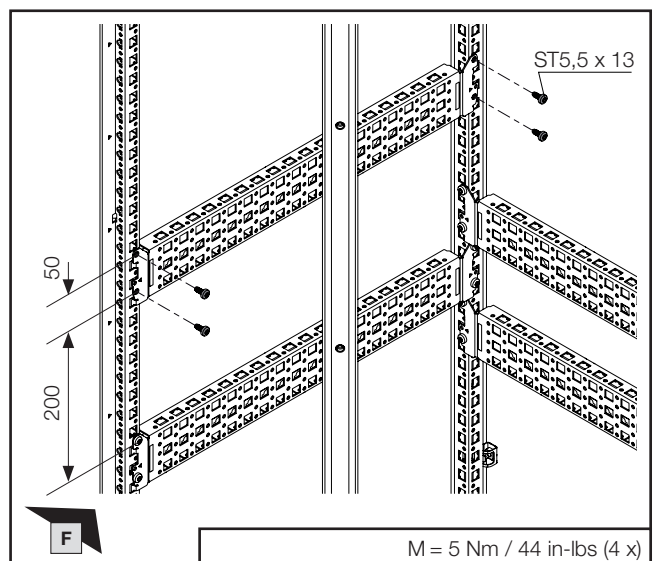
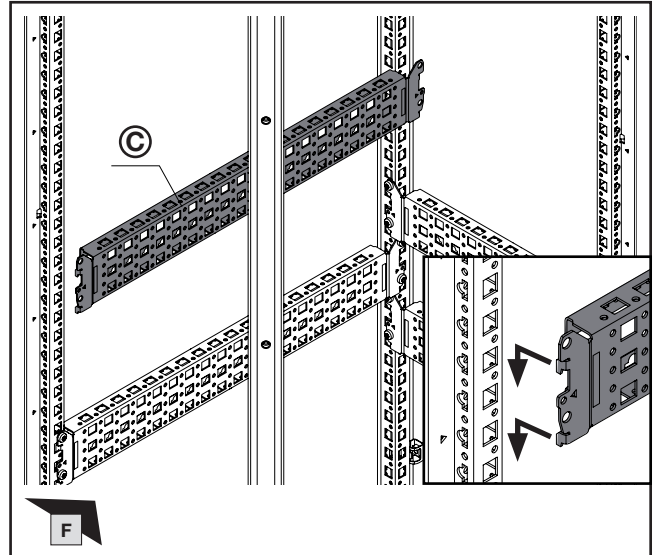
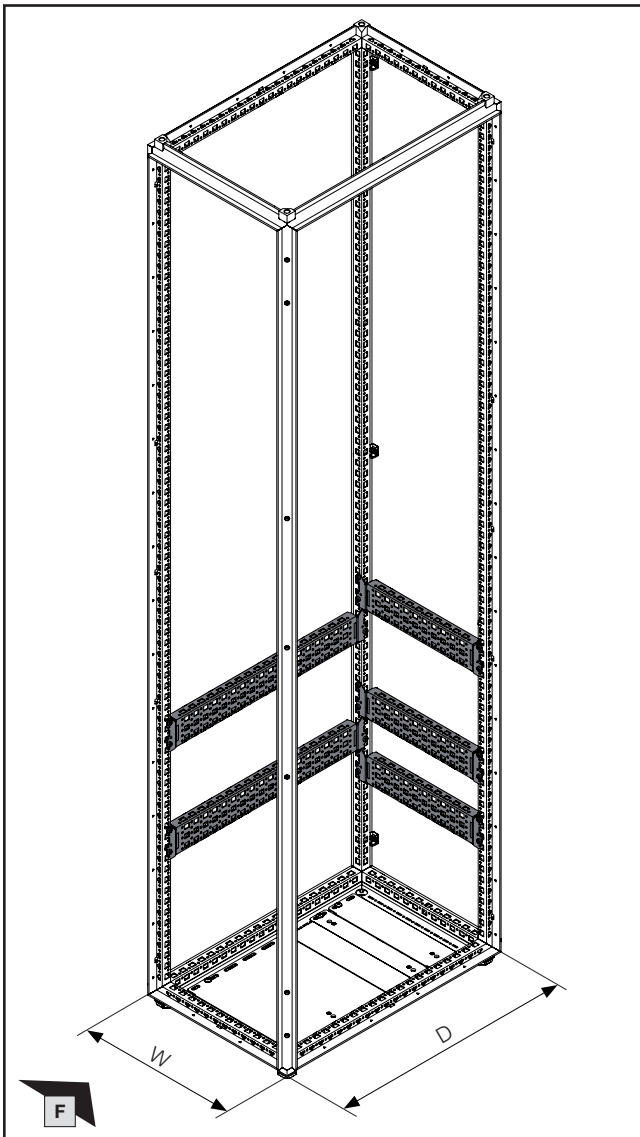

D mm	W mm	© / © Best.-Nr. Model No. Référence
x	400	8617.110
600	x	8617.130
800	x	8617.140

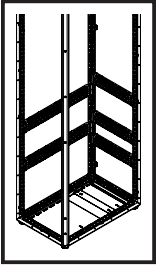

- 2. Montage Hochführungsfeld
- 2. Fitting the riser section
- 2. Montage de zone d'installation verticale

- 2.3 Montage untere System-Chassis
- 2.3 Fitting the lower punched sections with mounting flanges
- 2.3 Montage sous rails de montage

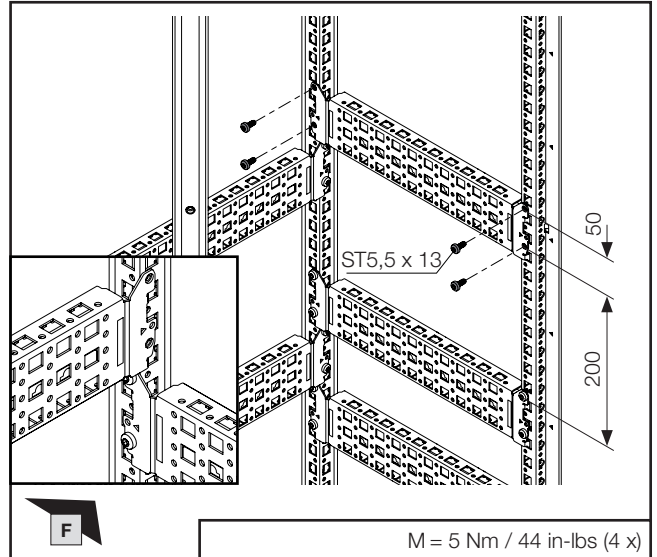
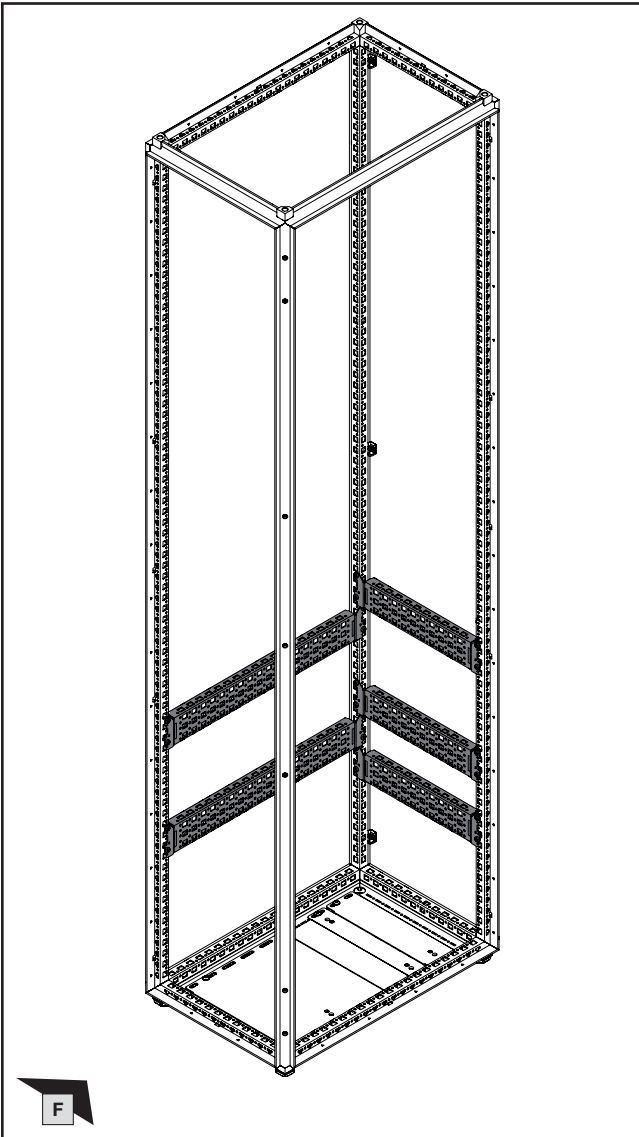

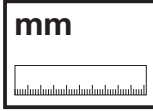
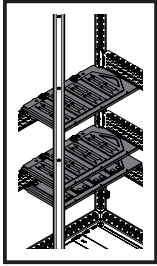

**2. Montage Hochführungsfeld**  
**2. Fitting the riser section**  
**2. Montage de zone d'installation verticale**

- 2.4 Montage untere Sammelschienenhalter horizontal
- 2.4 Fitting the lower busbar supports, horizontal
- 2.4 Montage des supports de jeux de barres horizontaux inférieurs

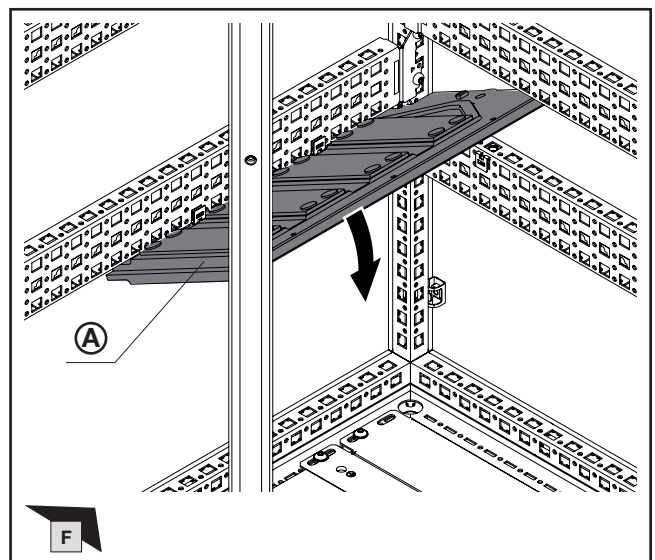
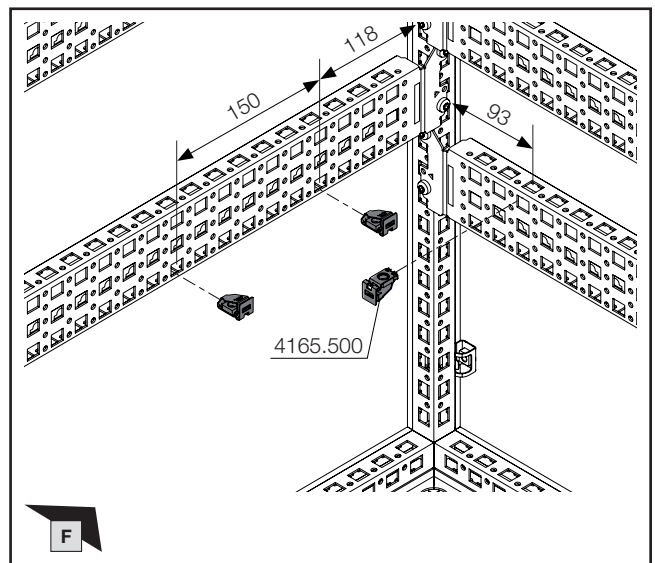
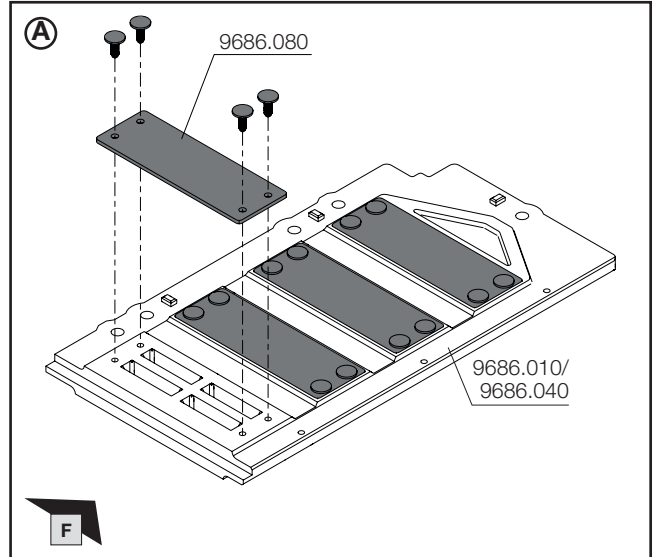
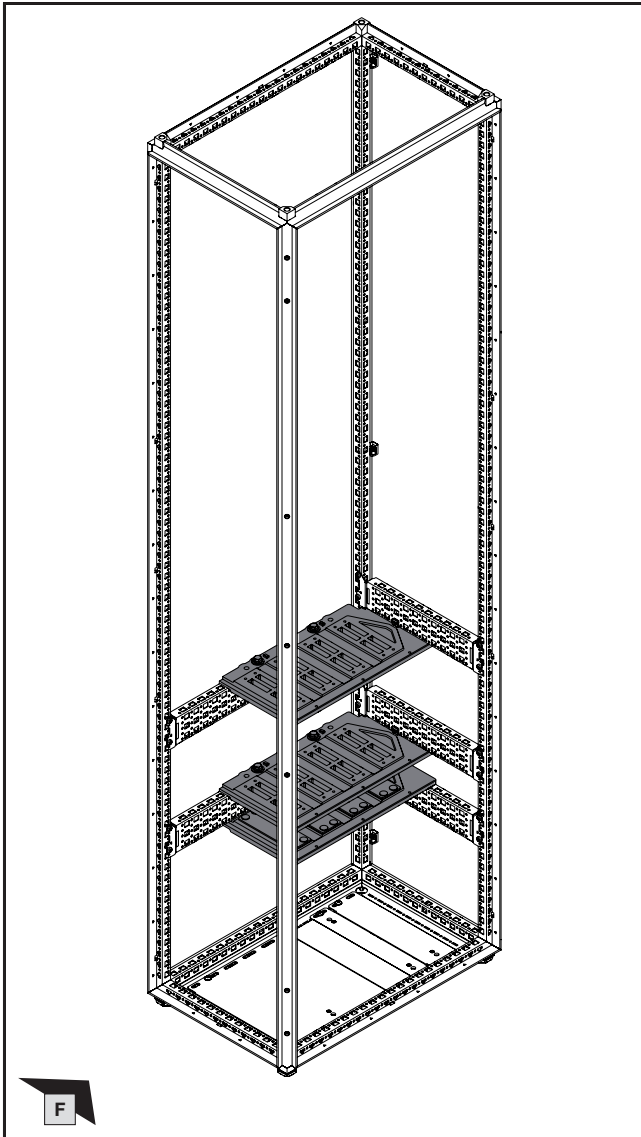

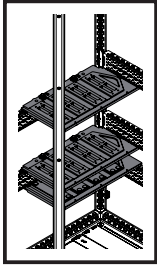

2. Montage Hochführungsfeld  
 2. Fitting the riser section  
 2. Montage de zone d'installation verticale

- 2.4 Montage untere Sammelschienenhalter horizontal
- 2.4 Fitting the lower busbar supports, horizontal
- 2.4 Montage des supports de jeux de barres horizontaux inférieurs

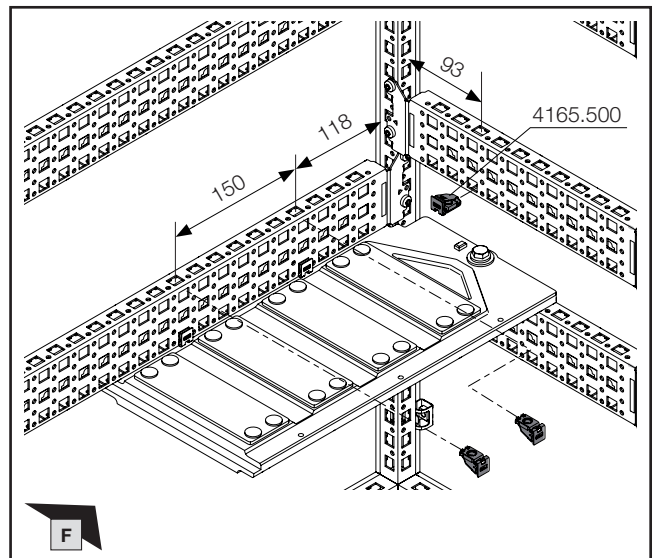
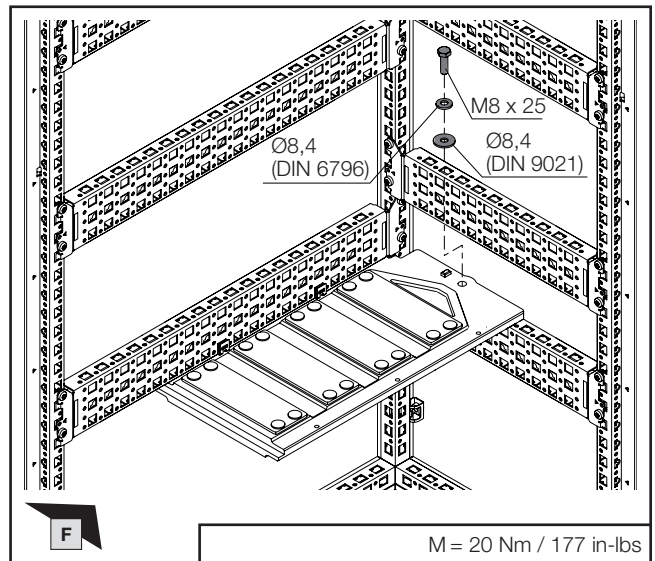
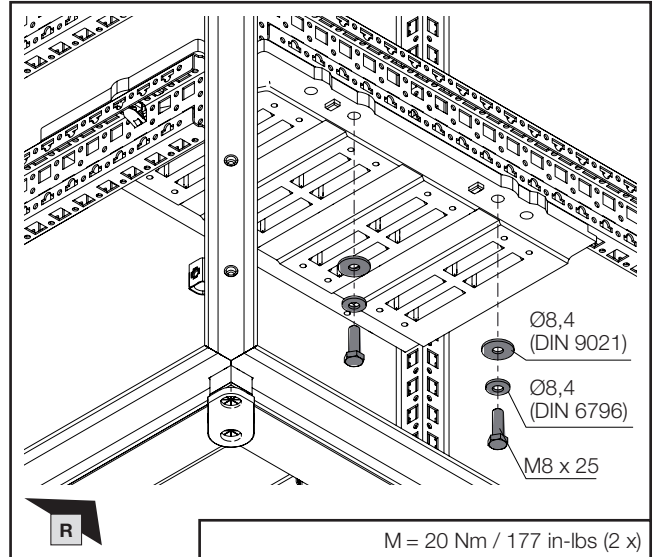
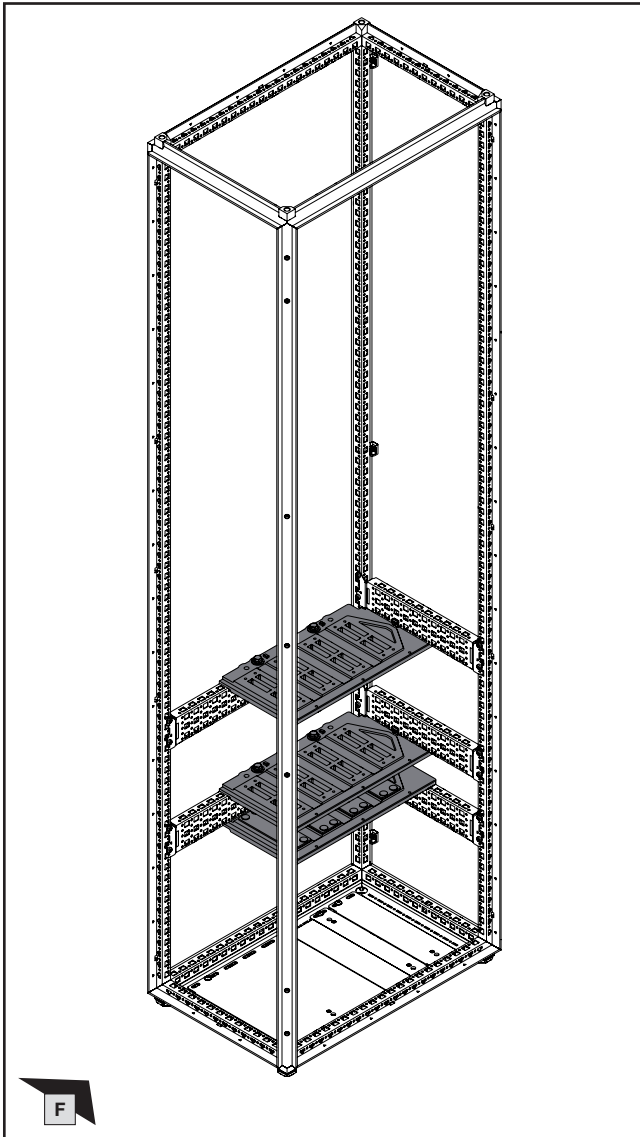

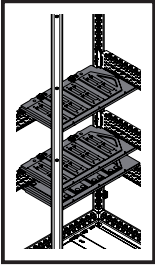

SW13



DE EN FR



## 2. Montage Hochführungsfeld

## 2. Fitting the riser section

## 2. Montage de zone d'installation verticale

- 2.4 Montage untere Sammelschienenhalter horizontal
- 2.4 Fitting the lower busbar supports, horizontal
- 2.4 Montage des supports de jeux de barres horizontaux inférieurs

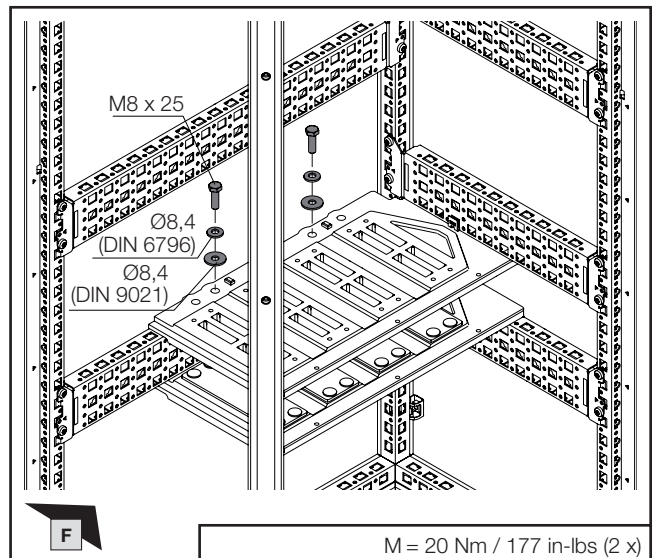
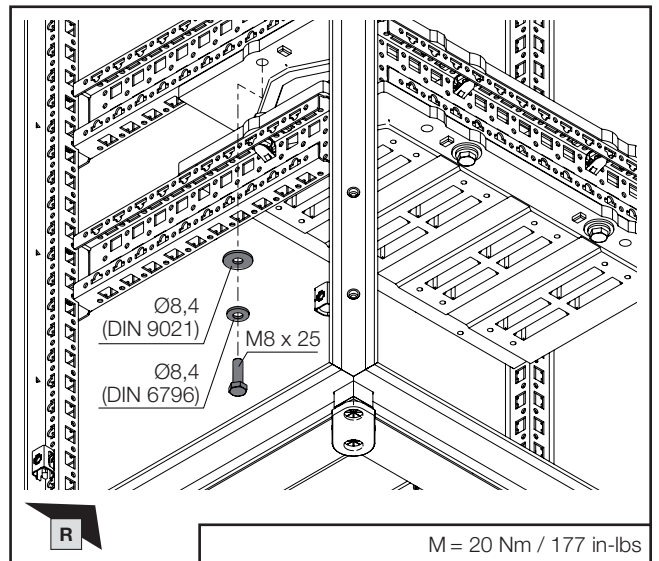
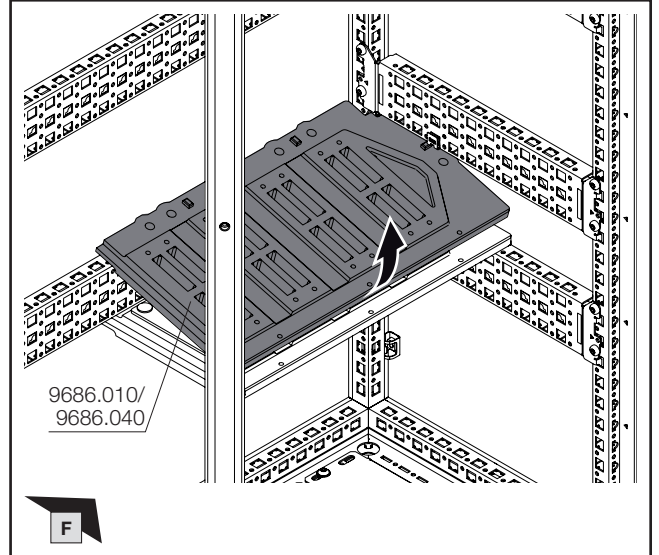
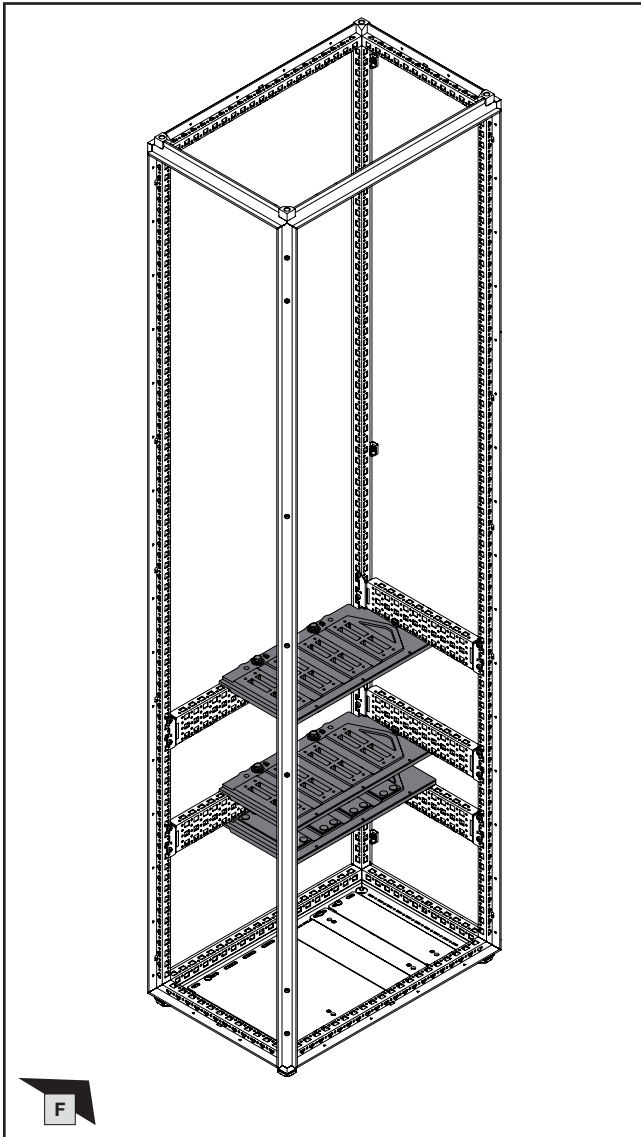

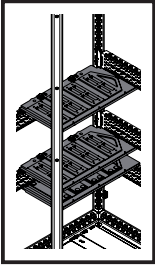

**2. Montage Hochführungsfeld**  
**2. Fitting the riser section**  
**2. Montage de zone d'installation verticale**

- 2.4 Montage untere Sammelschienenhalter horizontal
- 2.4 Fitting the lower busbar supports, horizontal
- 2.4 Montage des supports de jeux de barres horizontaux inférieurs

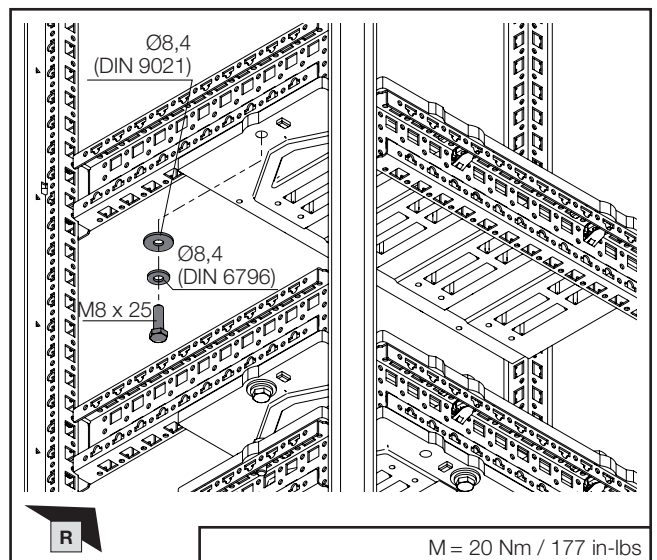
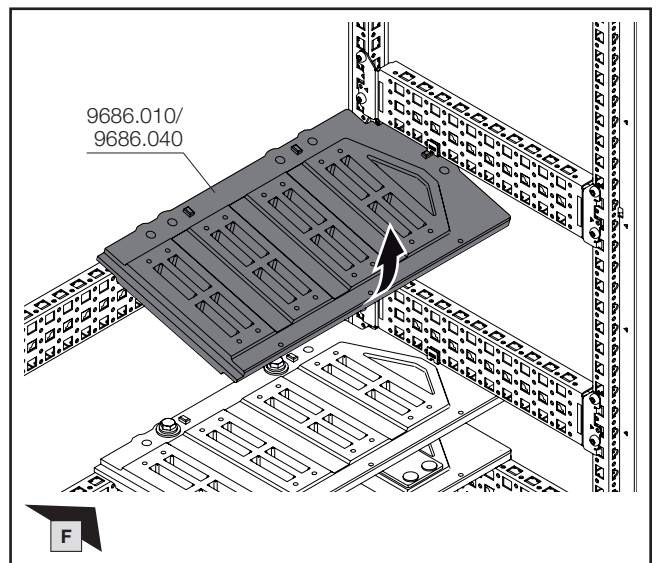
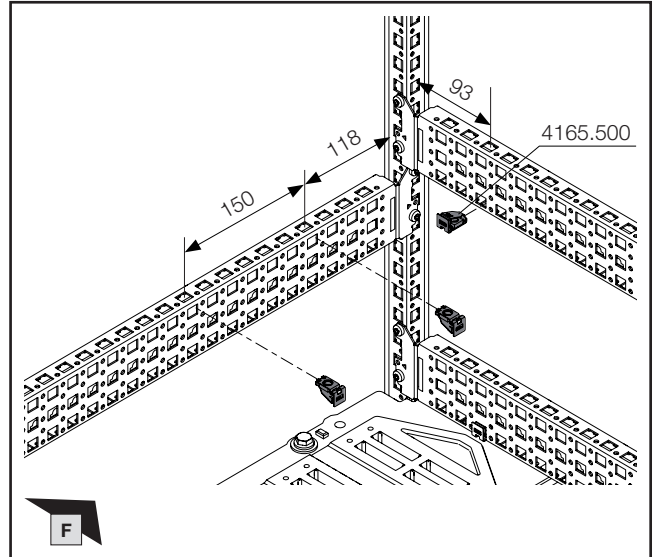
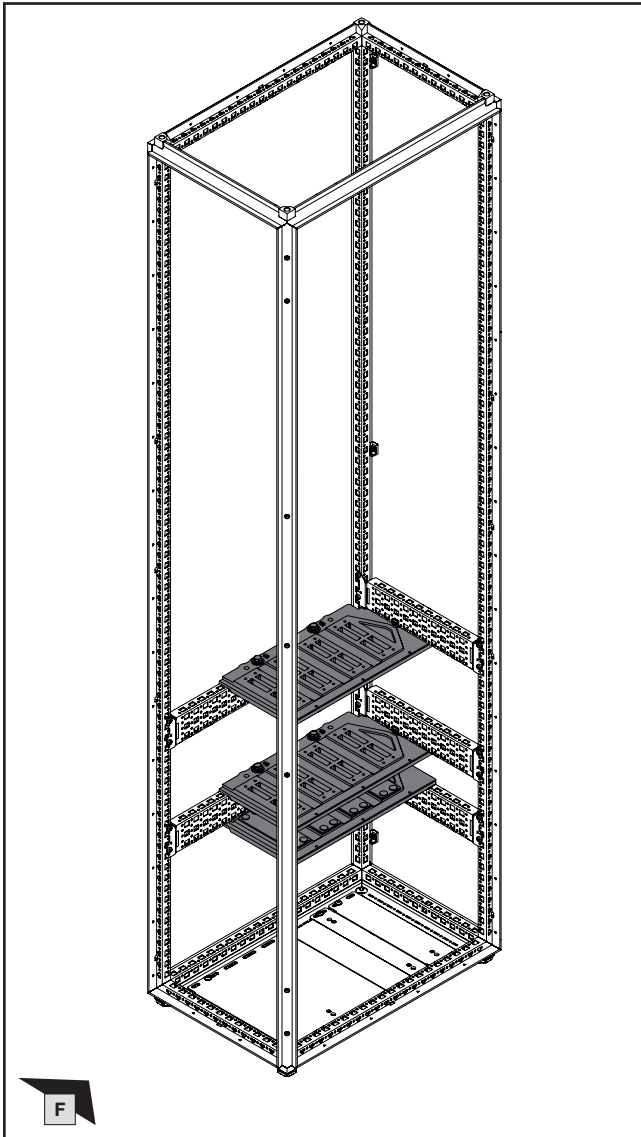

M = 20 Nm / 177 in-lbs

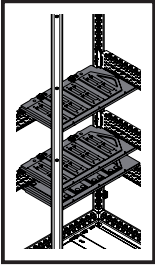

SW13



DE EN FR



2. Montage Hochführungsfeld
2. Fitting the riser section
2. Montage de zone d'installation verticale

- 2.4 Montage untere Sammelschienenhalter horizontal
- 2.4 Fitting the lower busbar supports, horizontal
- 2.4 Montage des supports de jeux de barres horizontaux inférieurs

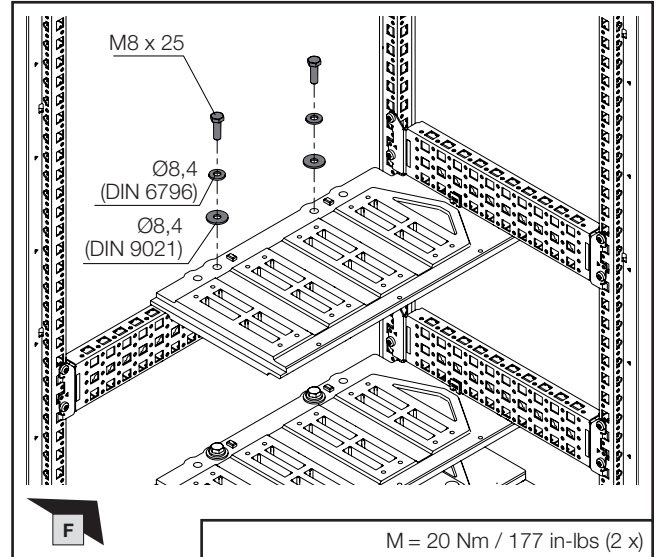
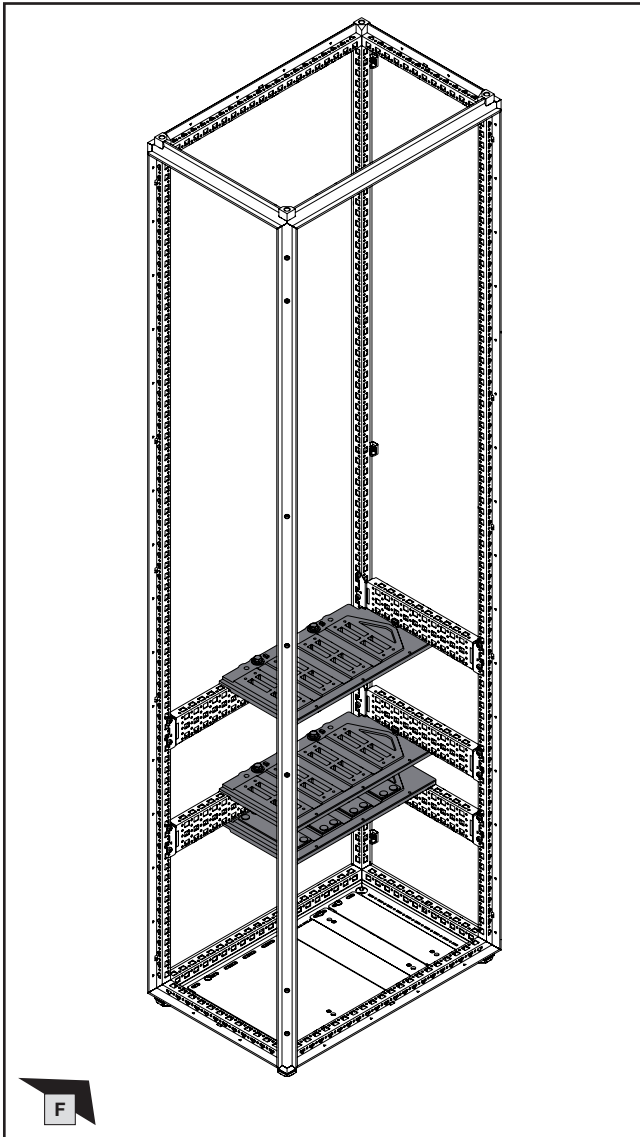

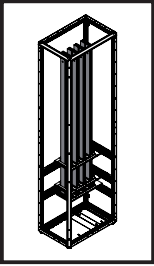

2. Montage Hochführungsfeld  
 2. Fitting the riser section  
 2. Montage de zone d'installation verticale

- 2.5 Einbringung vertikale Verteilsammelschienen
- 2.5 Incorporating the vertical distribution busbars
- 2.5 Introduction des jeux de barres de distribution verticaux

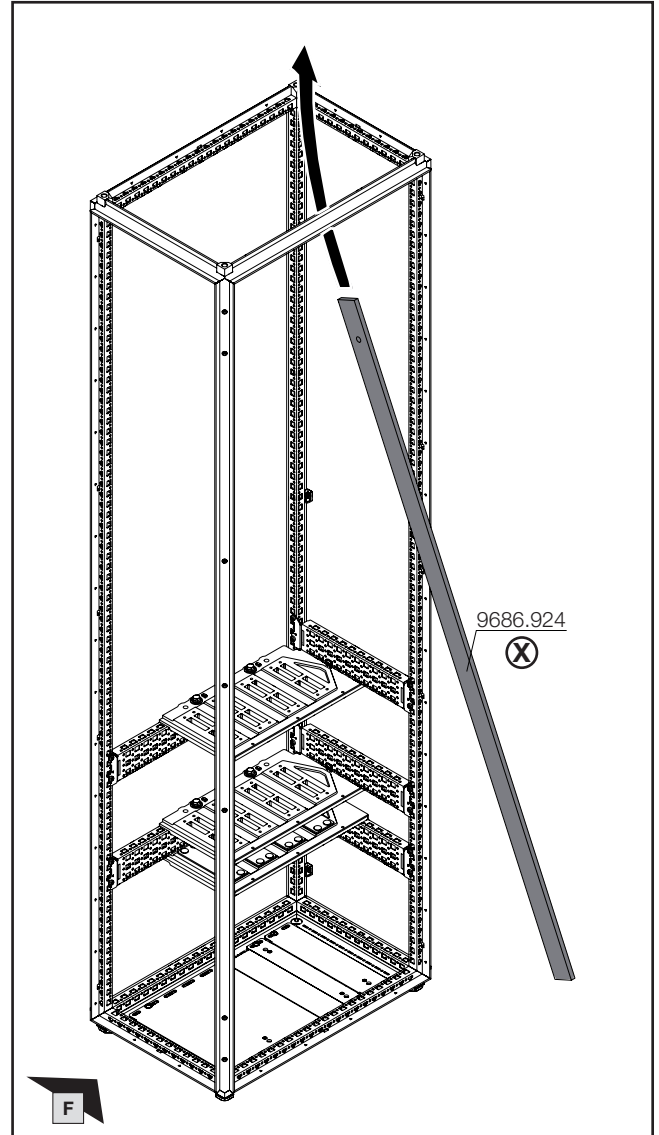
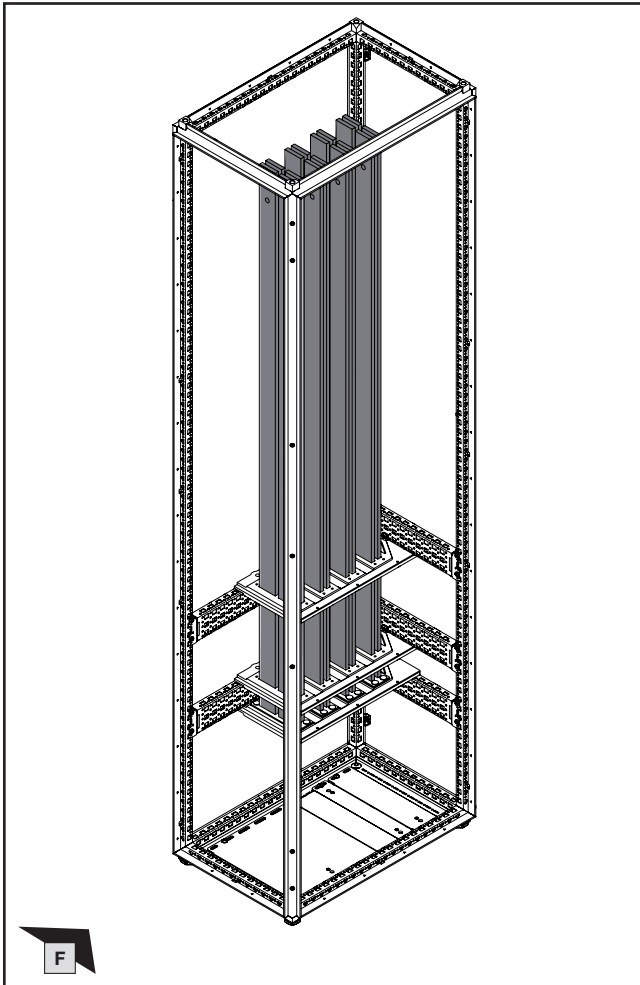

Hinweis / Note / Remarque **(X)**  
 Die Länge der Sammelschienen wird mit Hilfe der Online-Berechnungssoftware „RiPower“ im Niederspannungsschaltanlagen Konfigurator ermittelt.  
 The length of the busbars is determined using the online calculation software "RiPower" in the low-voltage switchgear configurator.  
 La longueur des jeux de barres est déterminée à l'aide du logiciel de calcul en ligne « RiPower » du configurateur de TGBT.



RiPower

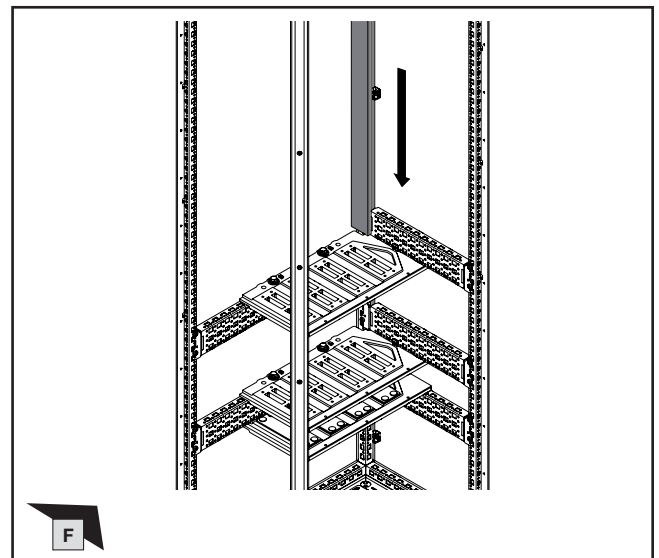

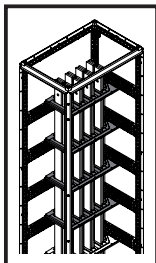

**2. Montage Hochführungsfeld**  
**2. Fitting the riser section**  
**2. Montage de zone d'installation verticale**

- 2.6 Montage obere System-Chassis und Sammelschienenhalter
- 2.6 Fitting the upper punched sections with mounting flanges and busbar supports
- 2.6 Montage des rails de montage supérieurs et des supports de jeux de barres

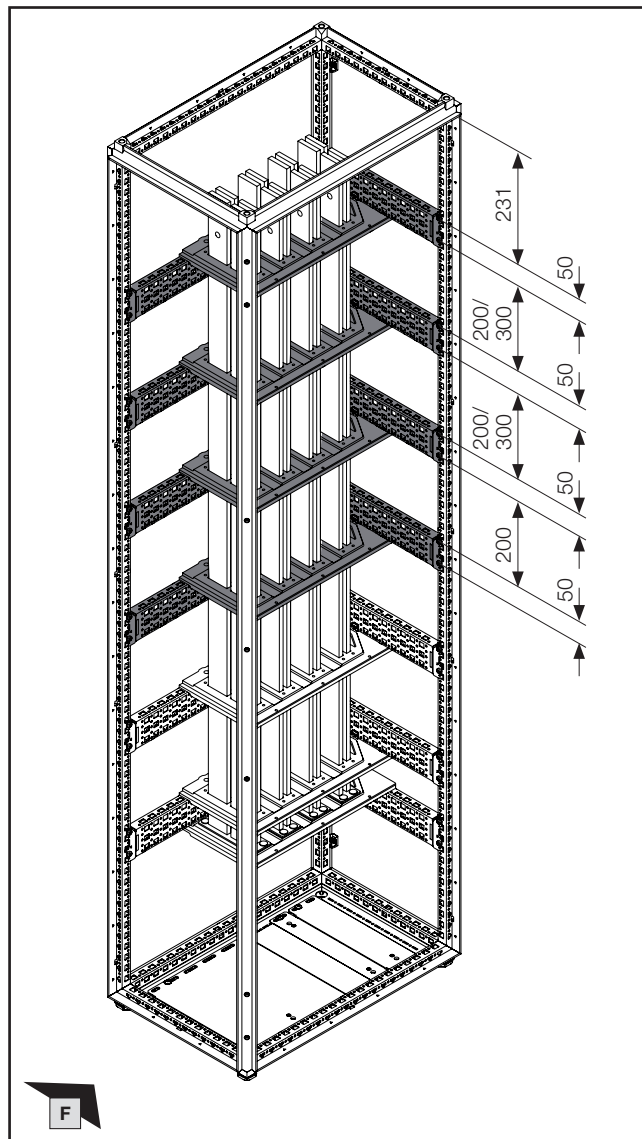
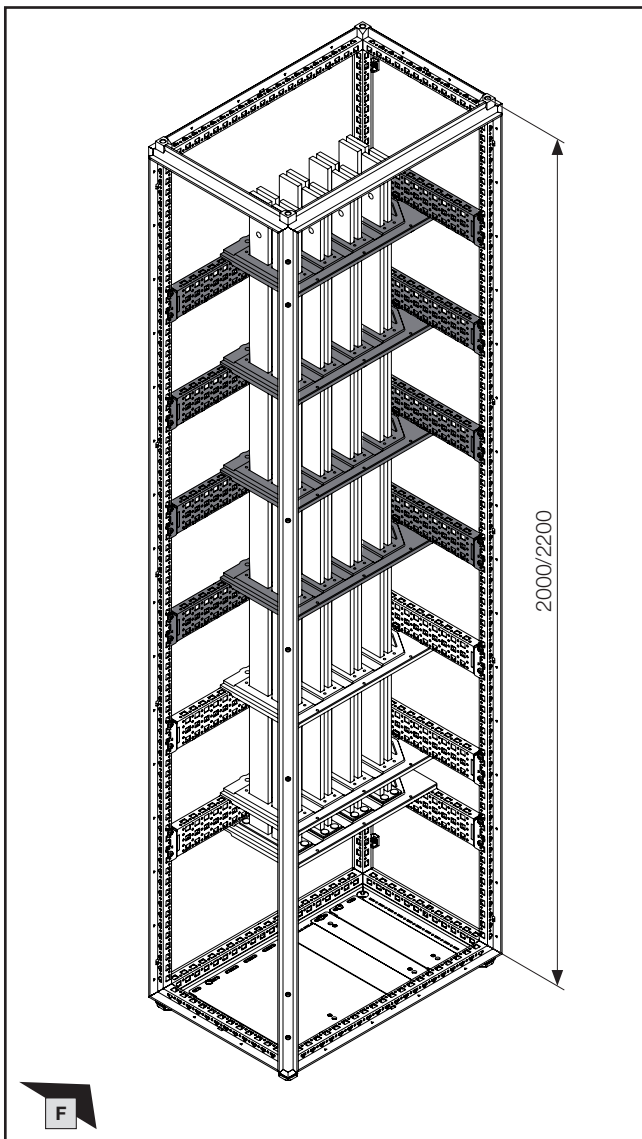

**Hinweis / Note / Remarque**

Bei erschwerter Montage Befestigungsschrauben der Sammelschienenhalter lösen und zum Abschluss des Montageschritts anziehen.

If fitting is difficult, loosen the assembly screws of the busbar supports and tighten them at the end of this step.

En cas de difficulté de montage, desserrer les vis de fixation des supports de jeux de barres et les resserrer en fin de montage.



**Hinweis / Note / Remarque**

Die Reihenfolge der Montage auf den nächsten drei Seiten ist schrittweise zu befolgen.

The assembly sequence on the next three pages must be followed step by step.

L'ordre de montage sur les trois prochaines pages doit être respecté étape par étape.

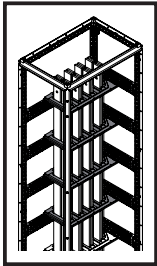

2. Montage Hochführungsfeld  
 2. Fitting the riser section  
 2. Montage de zone d'installation verticale

- 2.6 Montage obere System-Chassis und Sammelschienehalter
- 2.6 Fitting the upper punched sections with mounting flanges and busbar supports
- 2.6 Montage des rails de montage supérieurs et des supports de jeux de barres

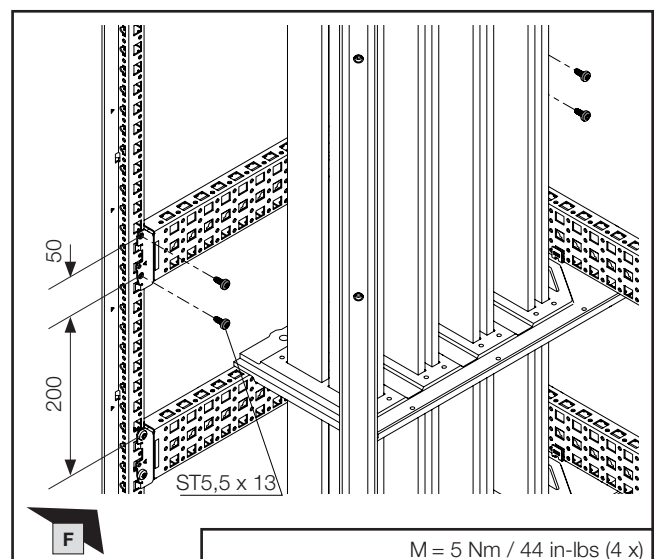
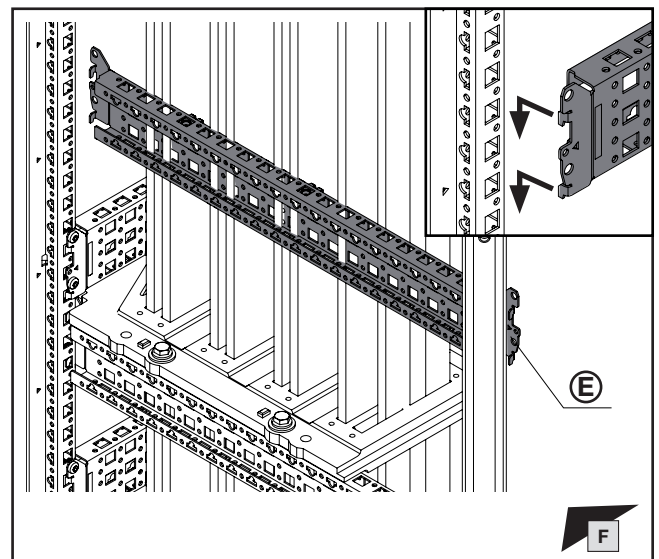
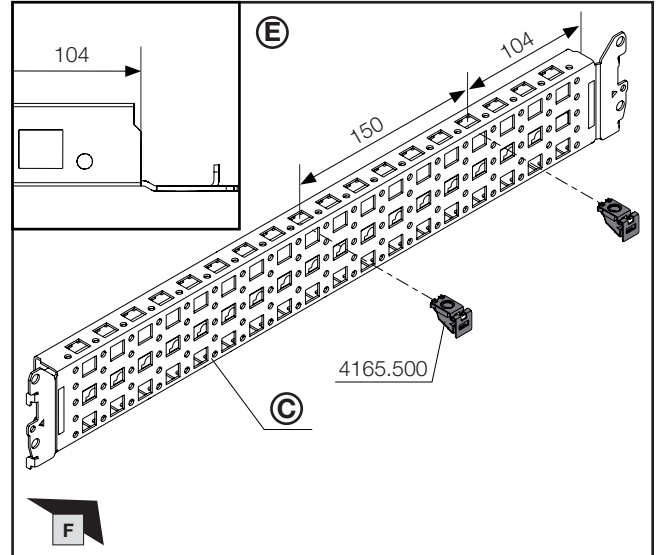
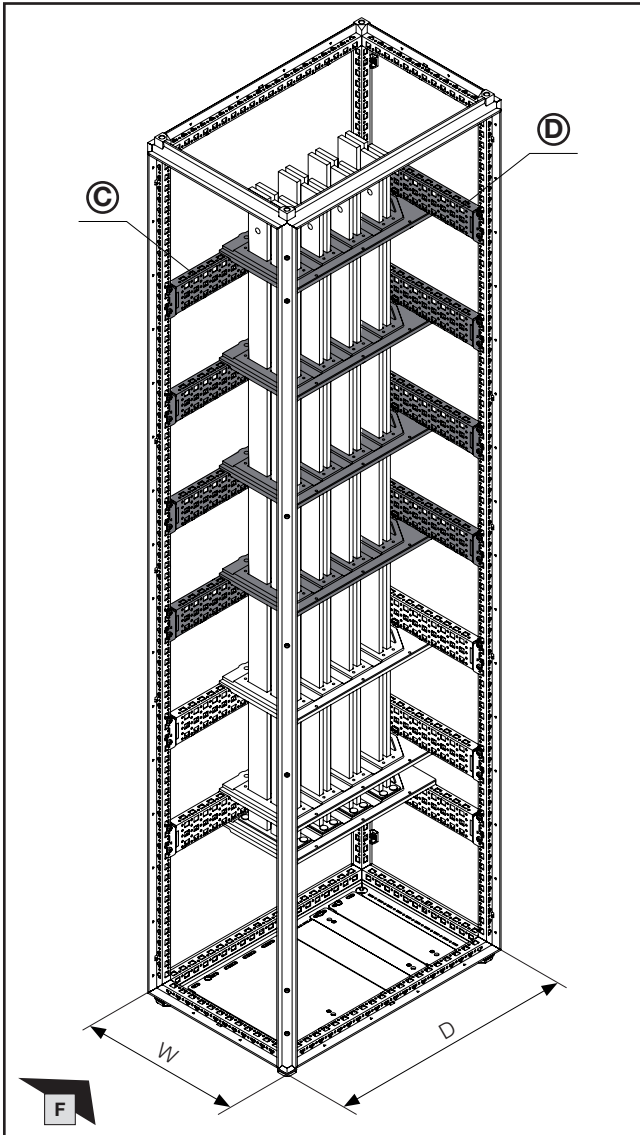

M = 5 Nm / 44 in-lbs (4 x)

D mm	W mm	© / © Best.-Nr. Model No. Référence
x	400	8617.110
600	x	8617.130
800	x	8617.140

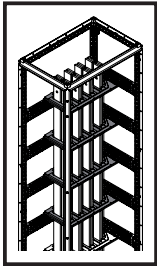

2. Montage Hochführungsfeld  
 2. Fitting the riser section  
 2. Montage de zone d'installation verticale

- 2.6 Montage obere System-Chassis und Sammelschienehalter
- 2.6 Fitting the upper punched sections with mounting flanges and busbar supports
- 2.6 Montage des rails de montage supérieurs et des supports de jeux de barres

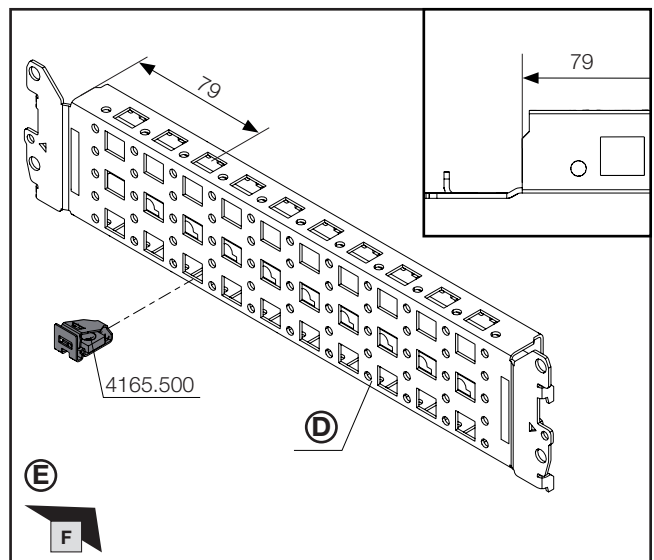
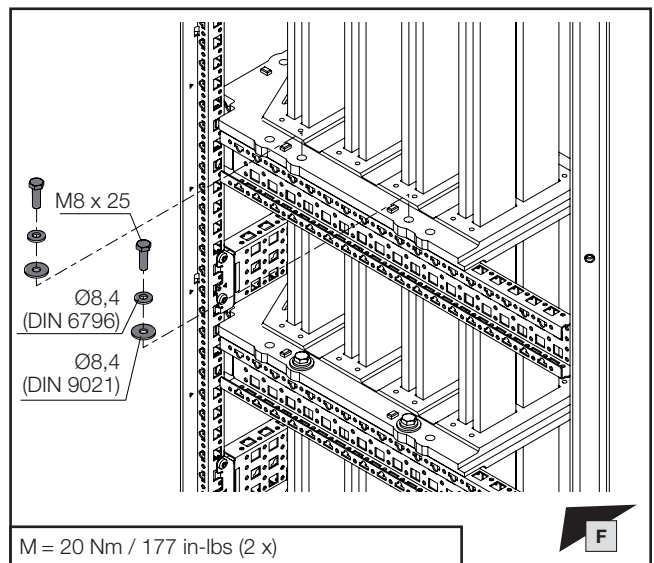
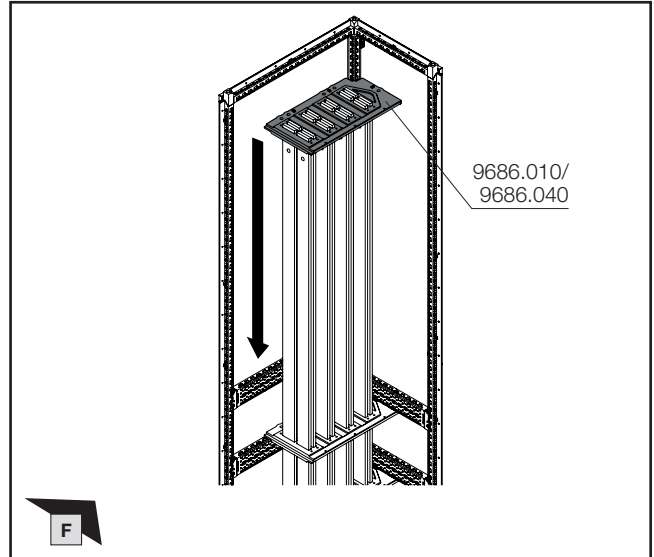
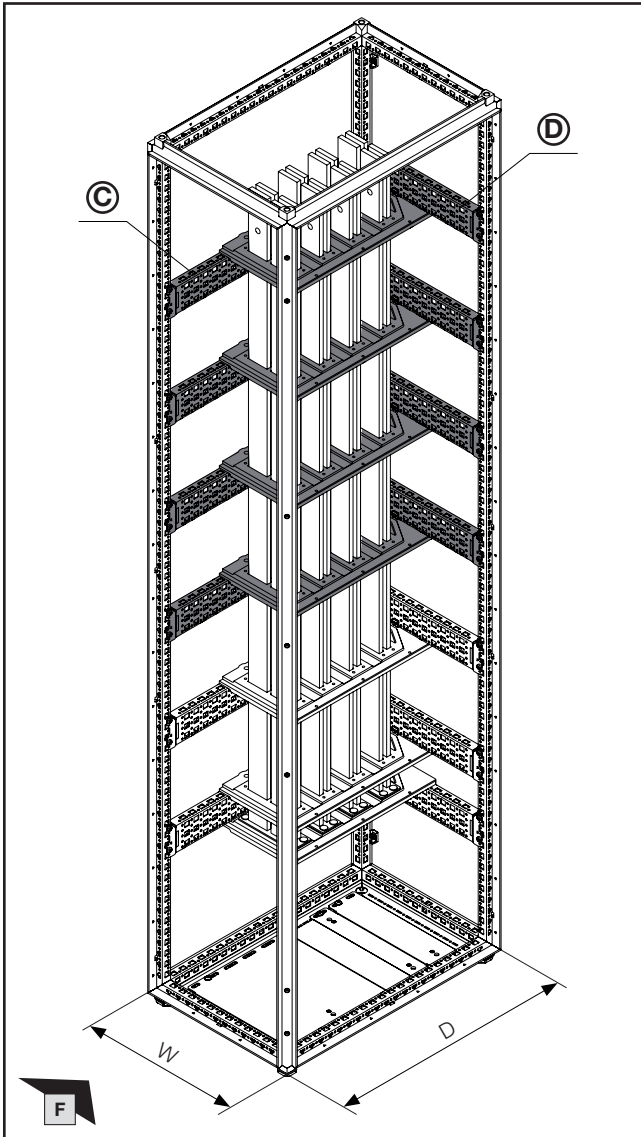

D mm	W mm	Best.-Nr. Model No. Référence
x	400	8617.110
600	x	8617.130
800	x	8617.140

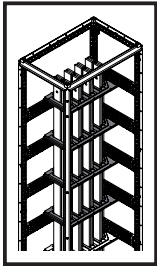

2. Montage Hochführungsfeld  
 2. Fitting the riser section  
 2. Montage de zone d'installation verticale

- 2.6 Montage obere System-Chassis und Sammelschienehalter
- 2.6 Fitting the upper punched sections with mounting flanges and busbar supports
- 2.6 Montage des rails de montage supérieurs et des supports de jeux de barres

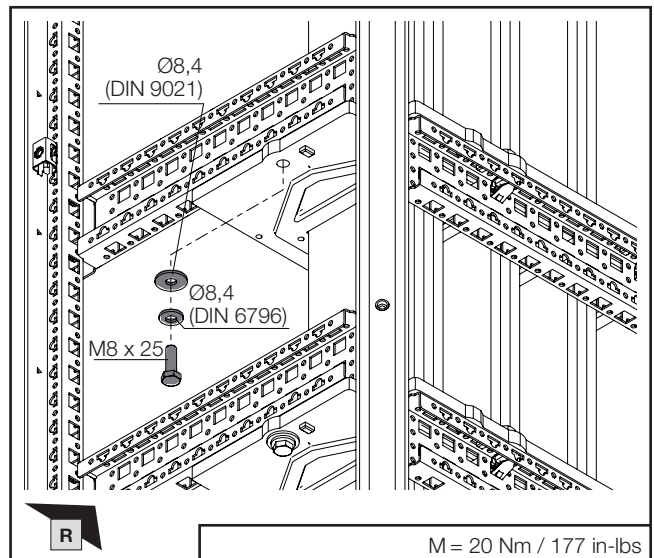
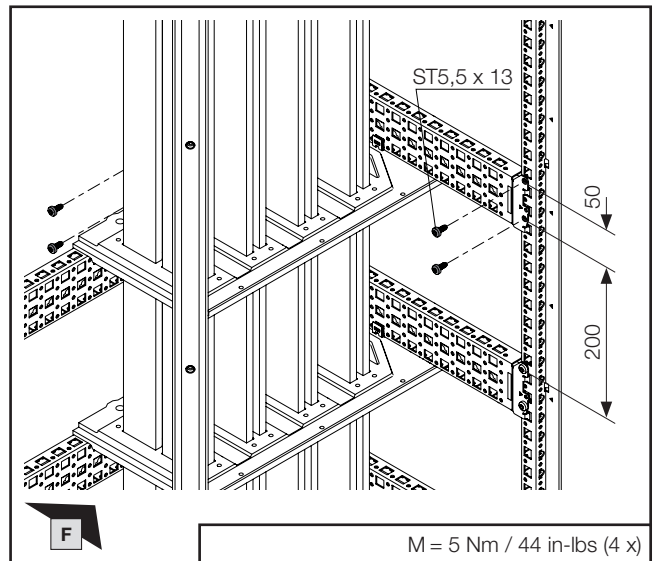
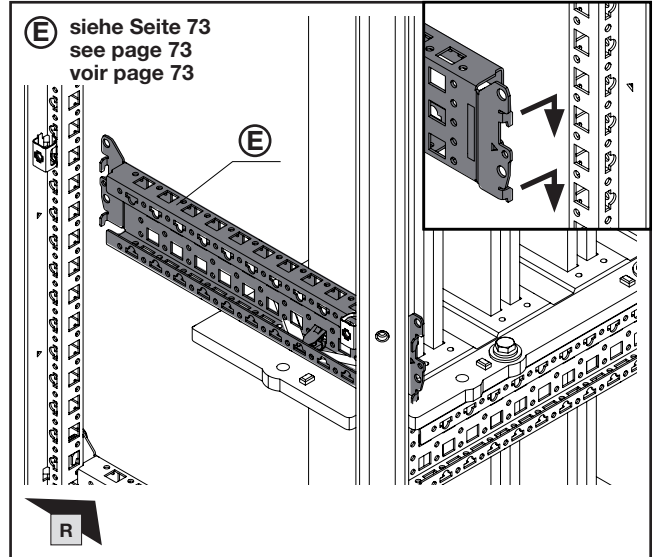
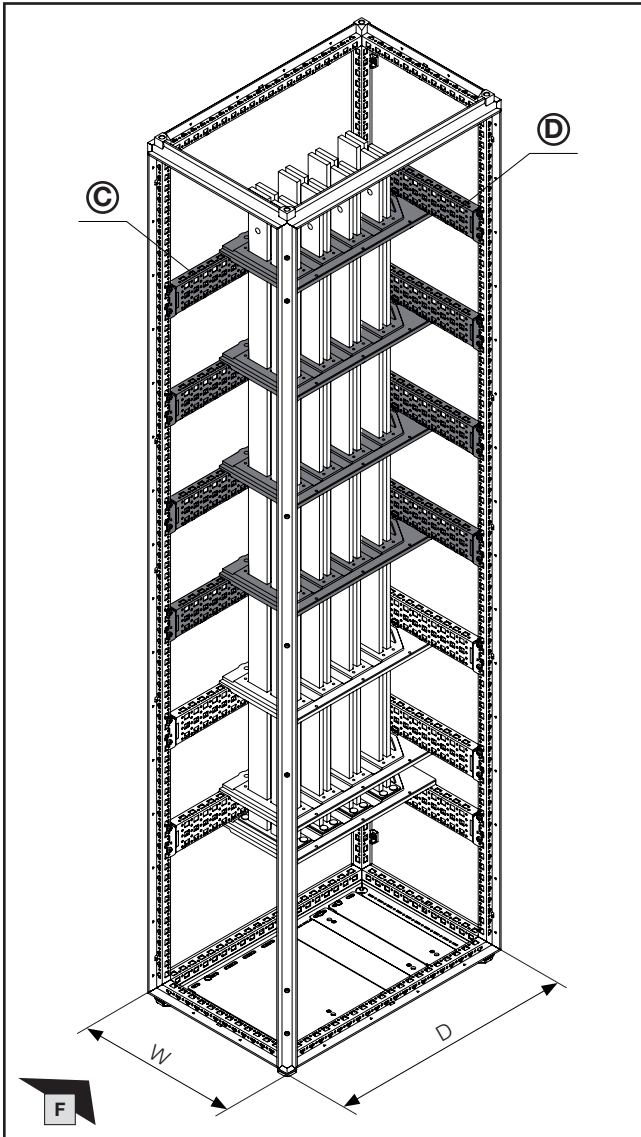

D mm	W mm	© / © Best.-Nr. Model No. Référence
x	400	8617.110
600	x	8617.130
800	x	8617.140

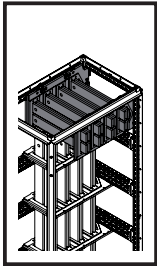

2. Montage Hochführungsfeld  
 2. Fitting the riser section  
 2. Montage de zone d'installation verticale

- 2.7 Montage des oberen Hauptschienensystems
- 2.7 Fitting the upper main busbar system
- 2.7 Montage des jeux de barres principaux supérieurs

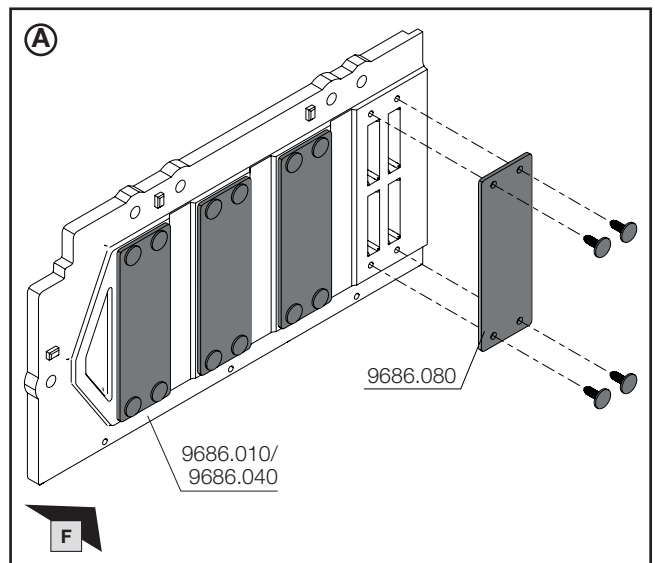
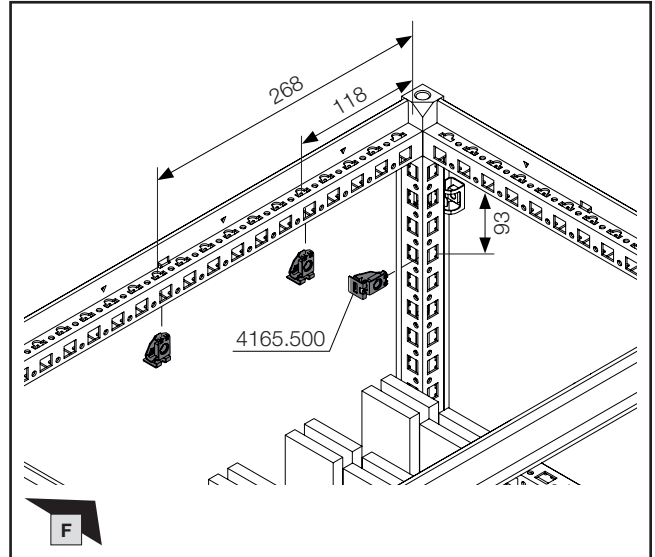
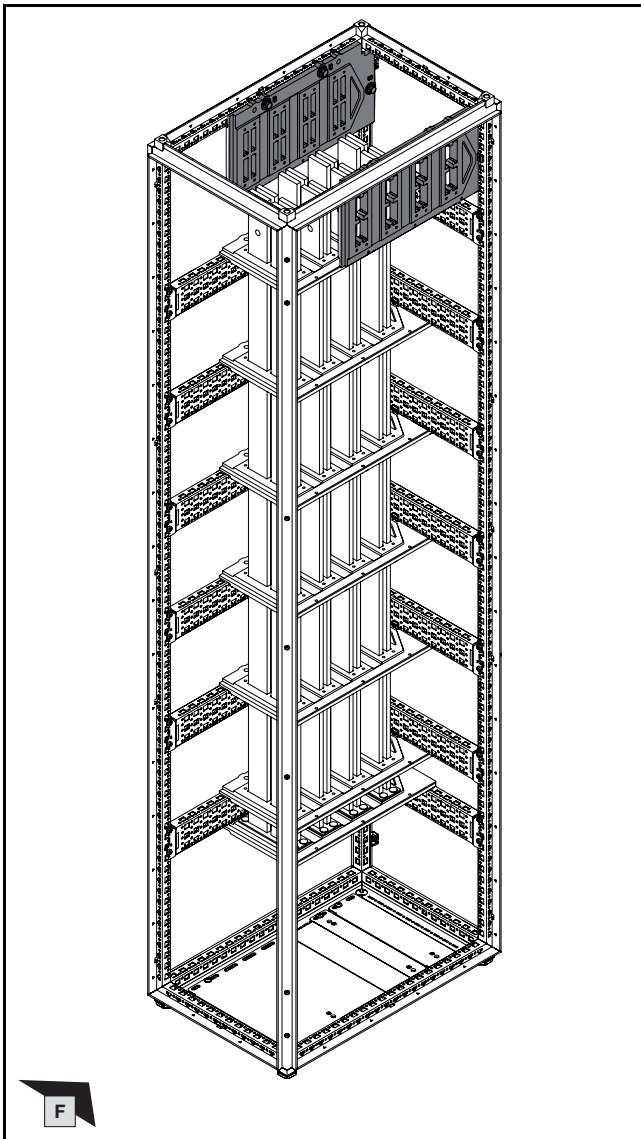

Montageanleitung VX25 Ri4Power – Schalt- und Energieverteilanlagen-System  
 Assembly instructions VX25 Ri4Power – Switchgear and power distribution system  
 Notice de montage VX25 Ri4Power – Distribution de courant

**DE/EN/FR**



**Hinweis / Note / Remarque**

Für Schutz Eigenschaft Störlichtbogenklasse B Montagerihenfolge in den entsprechenden Abschnitten der o. g. Anleitung beachten.

For arcing class B protection, please follow the assembly sequence as set out in the relevant chapters of the aforementioned assembly instructions.

Pour la protection contre les arcs électriques de catégorie B, suivez la séquence de montage indiquée dans les sections correspondantes des instructions ci-dessus.

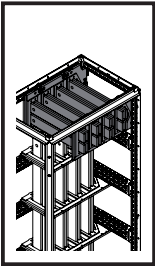

2. Montage Hochführungsfeld  
 2. Fitting the riser section  
 2. Montage de zone d'installation verticale

- 2.7 Montage des oberen Hauptschienensystems
- 2.7 Fitting the upper main busbar system
- 2.7 Montage des jeux de barres principaux supérieurs

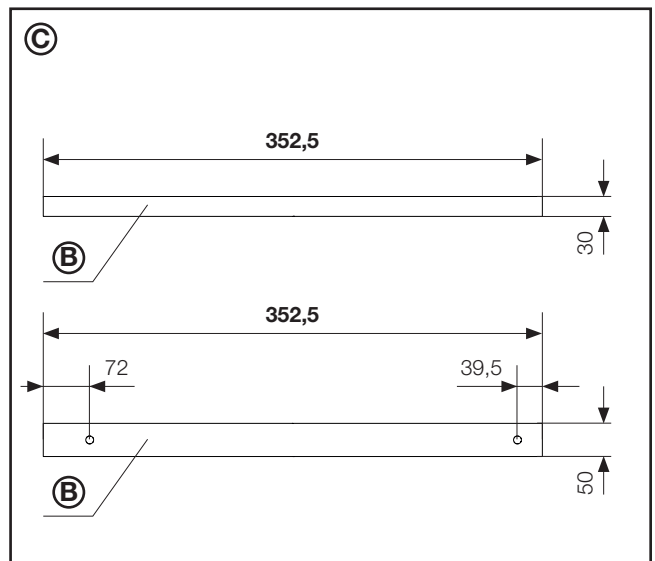
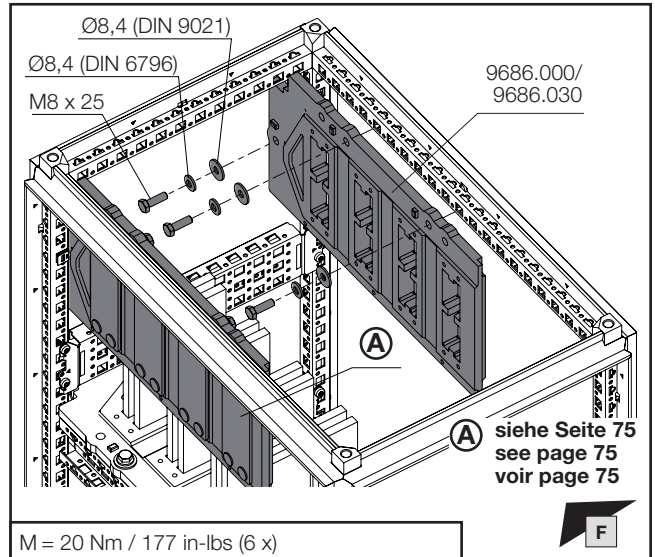
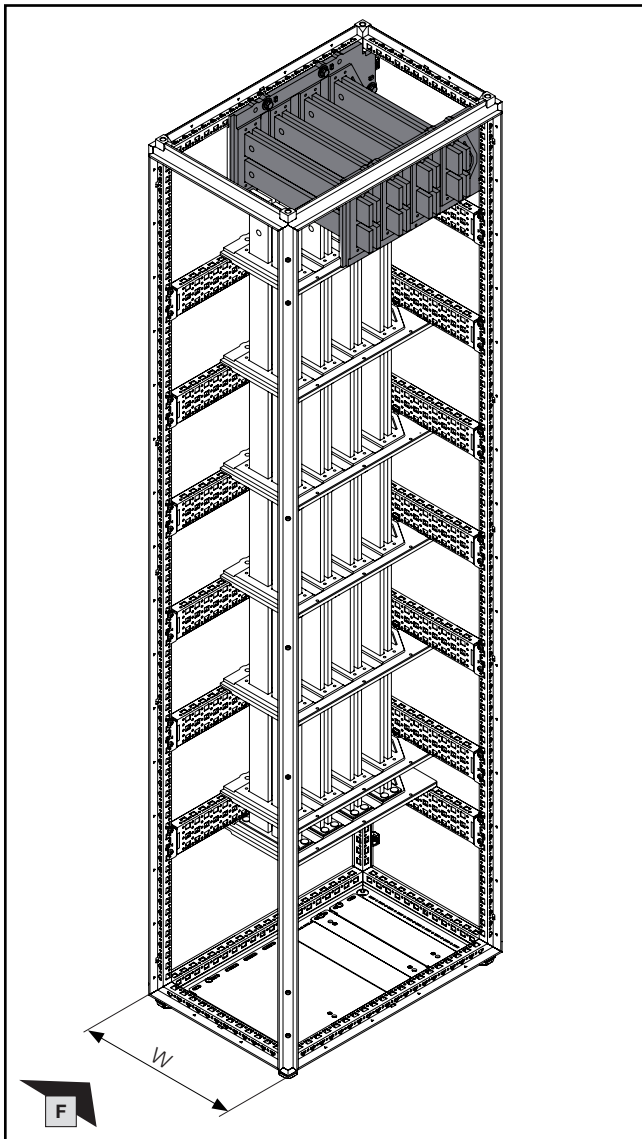

W mm	Sammelschiene Abmessung mm Busbar dimensions mm Dimensions de la barre mm	Best.-Nr. Model No. Référence
400	50 x 10	9684.004
-	30 x 10	3586.005

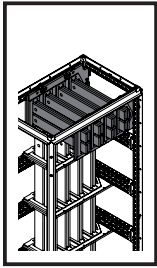

DE EN FR



## 2. Montage Hochführungsfeld

## 2. Fitting the riser section

## 2. Montage de zone d'installation verticale

- 2.7 Montage des oberen Hauptschienensystems
- 2.7 Fitting the upper main busbar system
- 2.7 Montage des jeux de barres principaux supérieurs

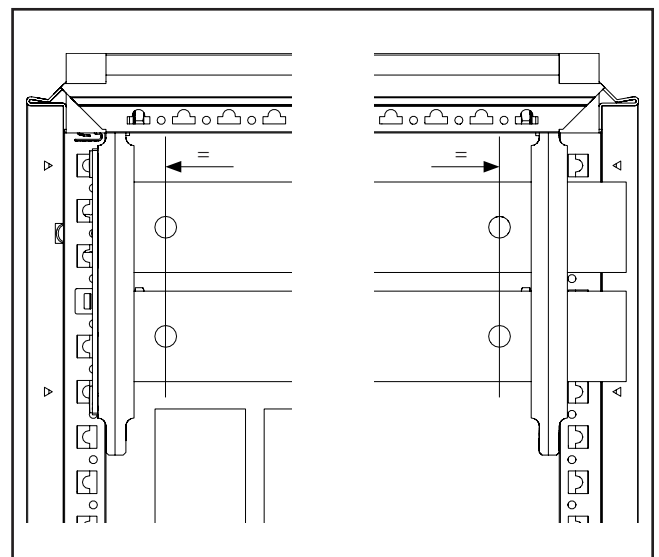
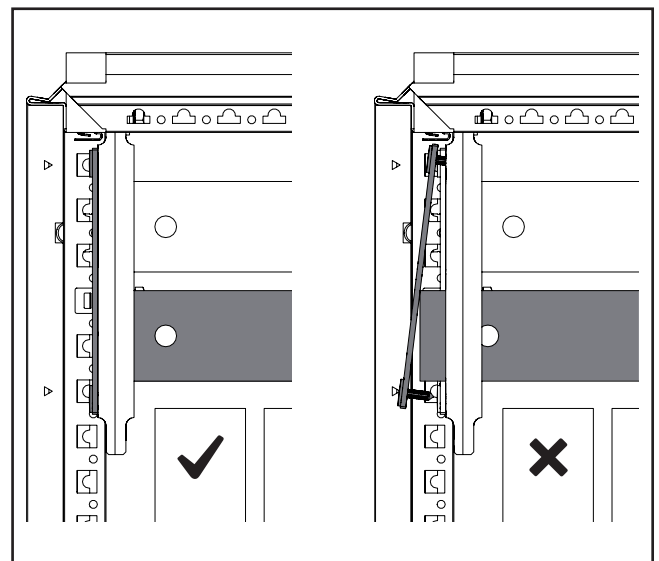
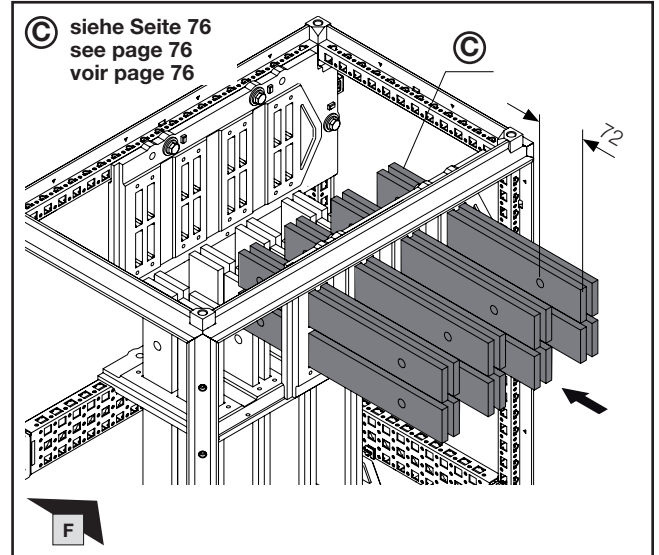
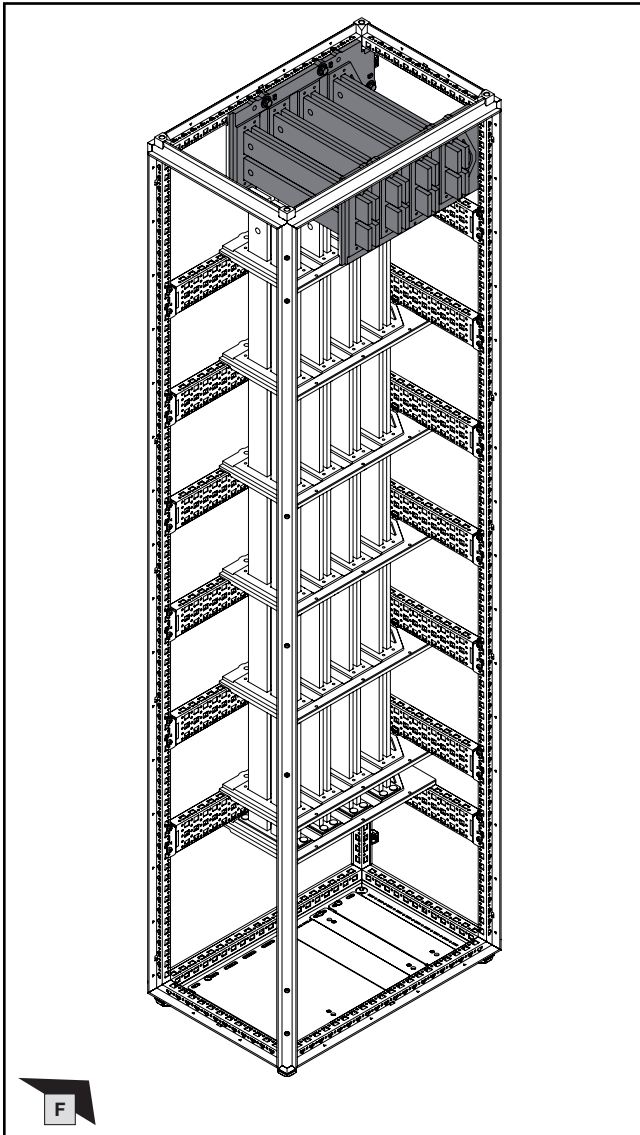

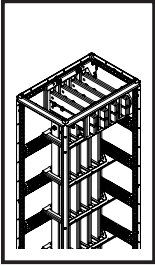

SW16/  
SW17

DE EN FR



2. Montage Hochführungsfeld
2. Fitting the riser section
2. Montage de zone d'installation verticale

- 2.8 Anbindung vertikales Verteilsammelschienensystem
- 2.8 Connecting the vertical multi-terminal busbar system
- 2.8 Connexion aux jeux de barres de distribution verticaux

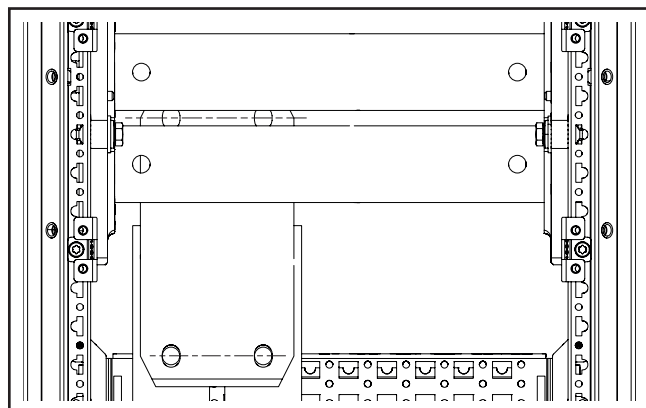
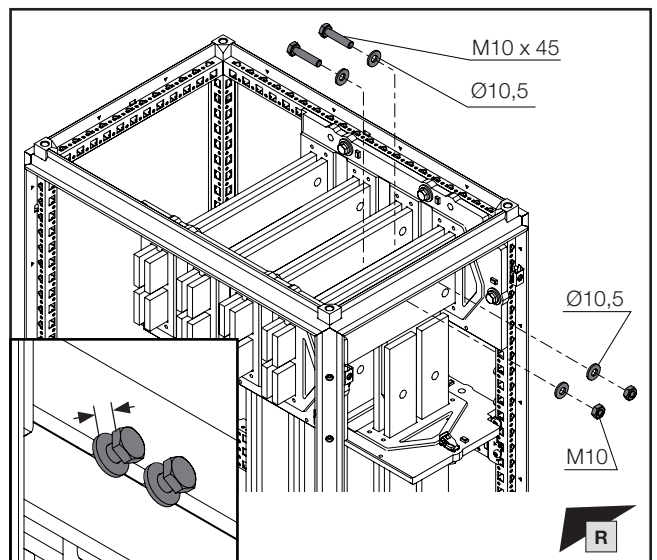
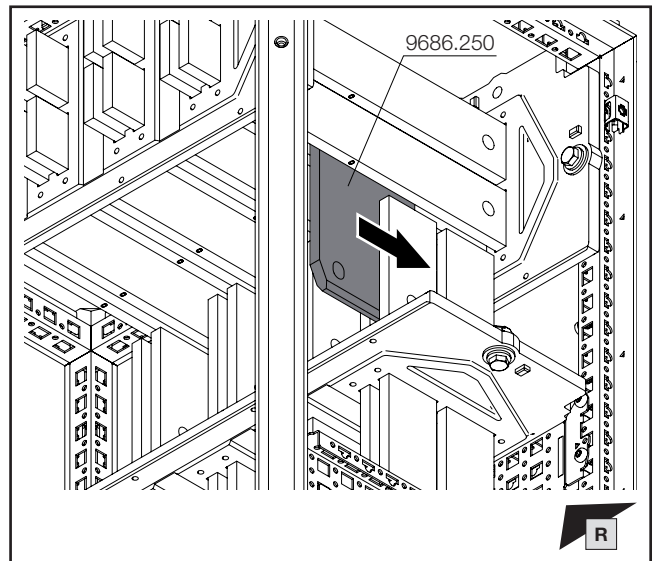
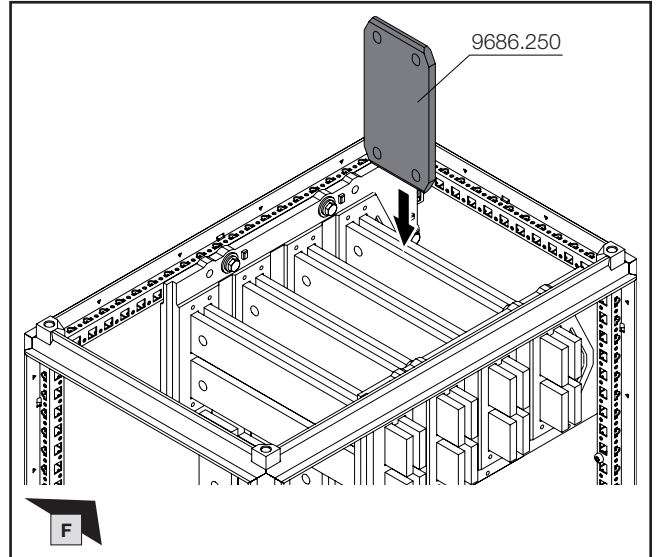
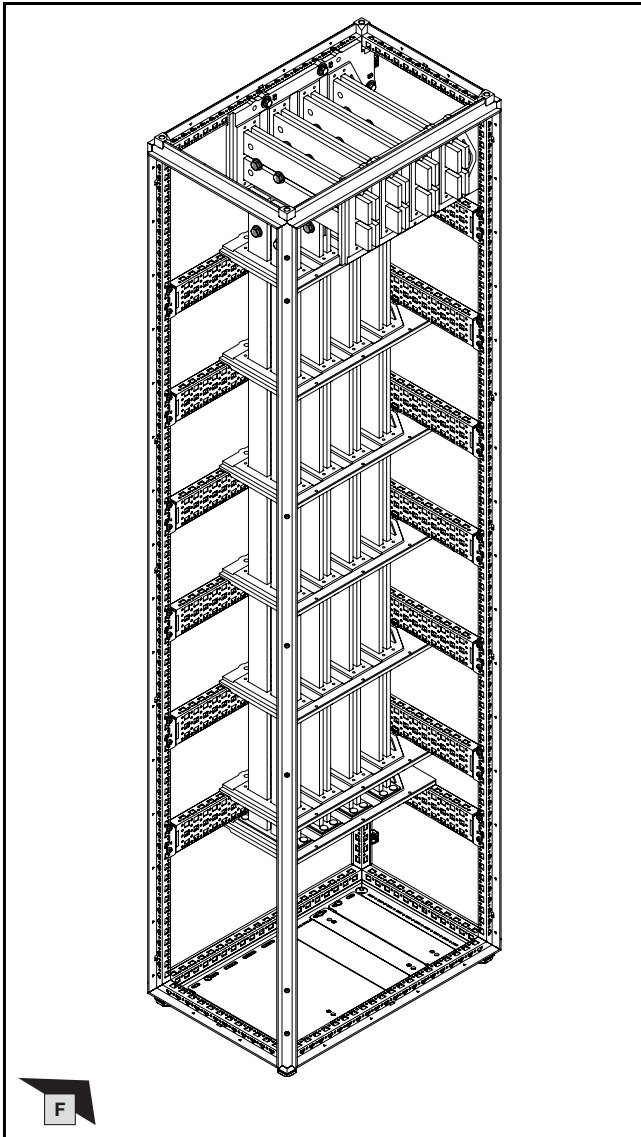

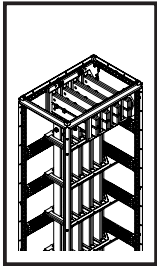

SW16/  
SW17



- 2. Montage Hochführungsfeld
- 2. Fitting the riser section
- 2. Montage de zone d'installation verticale

- 2.8 Anbindung vertikales Verteilsammelschienensystem
- 2.8 Connecting the vertical multi-terminal busbar system
- 2.8 Connexion aux jeux de barres de distribution verticaux

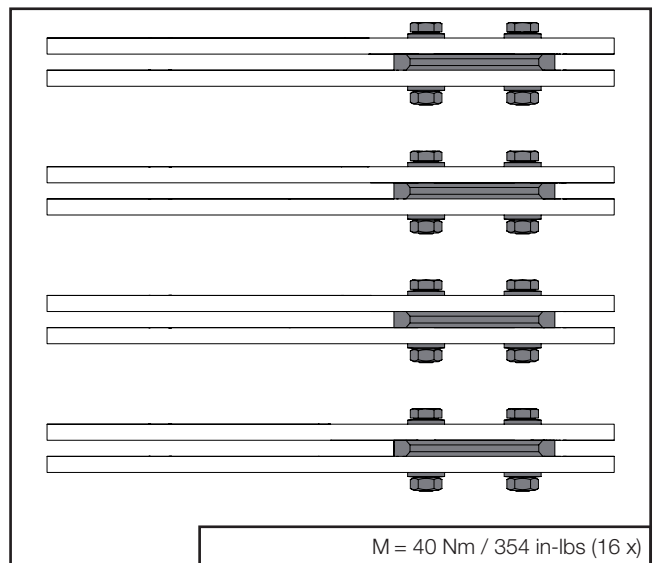
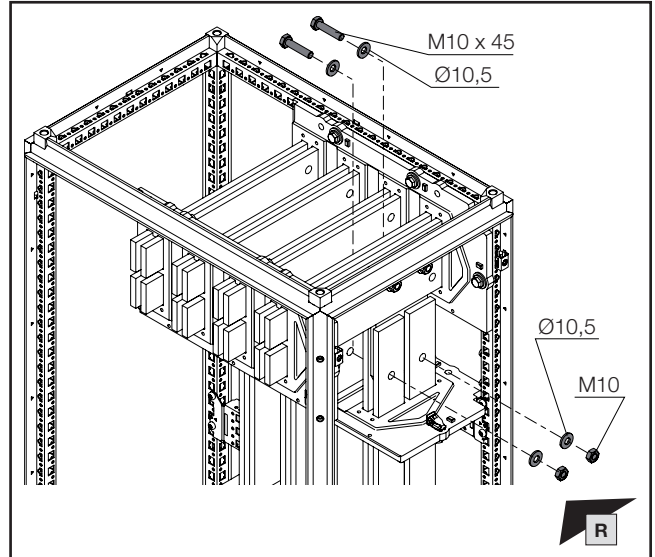
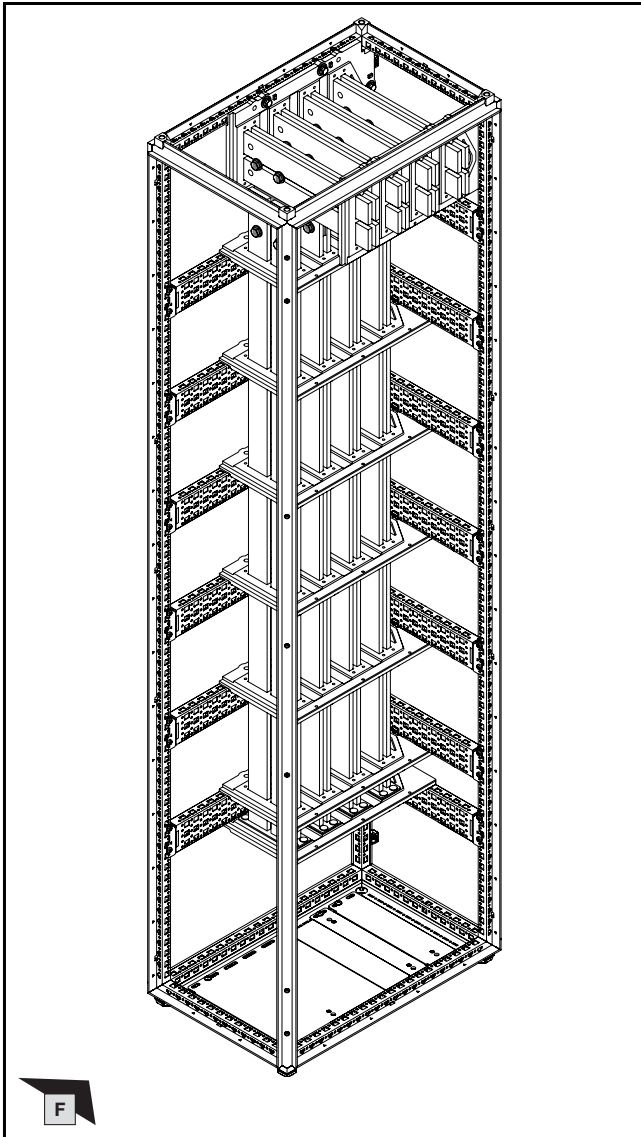

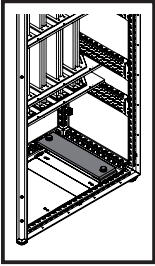

2. Montage Hochführungsfeld  
 2. Fitting the riser section  
 2. Montage de zone d'installation verticale

- 2.9 Montage des PE-/PEN-Sammelschienensystems
- 2.9 Fitting the PE/PEN busbar system
- 2.9 Montage des jeux de barres Terre / Terre-Neutre

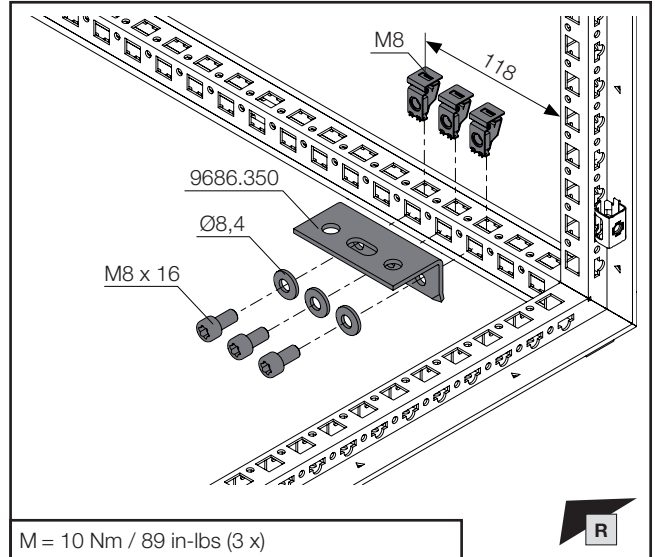
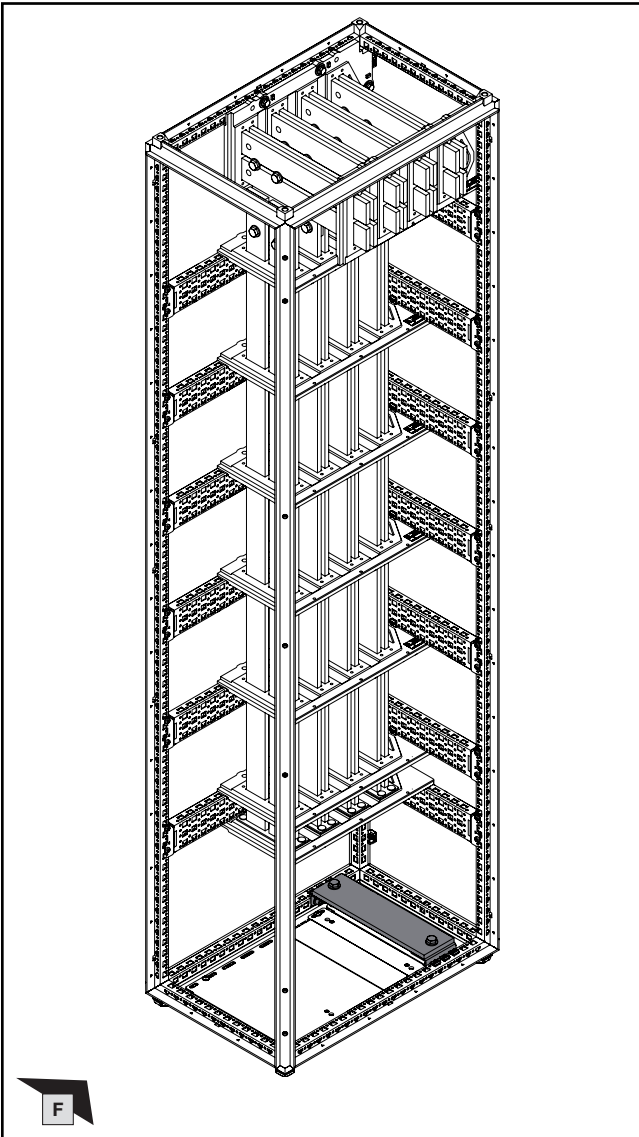

M = 10 Nm / 89 in-lbs (3 x)

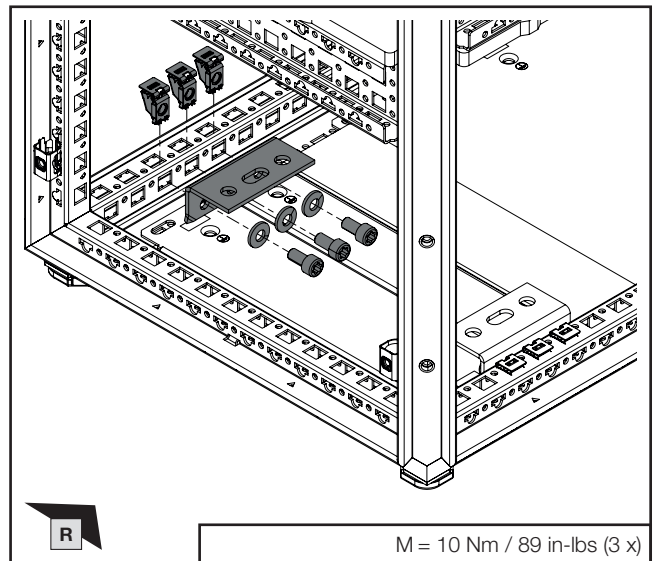

M = 10 Nm / 89 in-lbs (3 x)

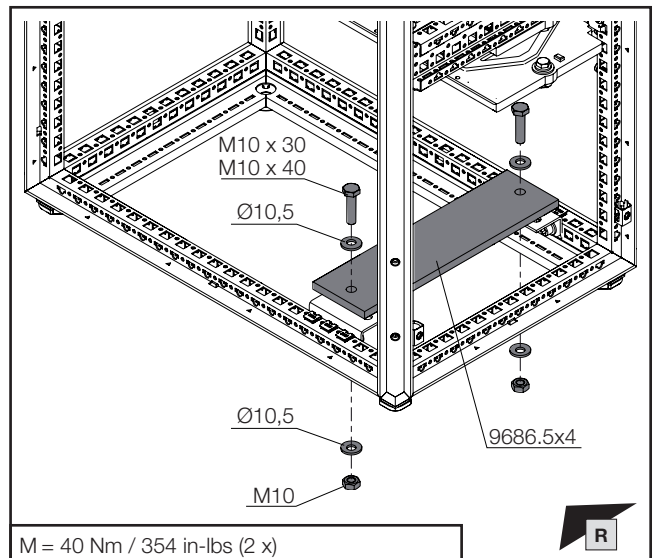

M = 40 Nm / 354 in-lbs (2 x)



Montageanleitung VX25 Ri4Power – Schalt- und Energieverteilanlagen-System

Assembly instructions VX25 Ri4Power – Switchgear and power distribution system

Notice de montage VX25 Ri4Power – Distribution de courant

DE/EN/FR

Schranksystem VX25 – Technische Dokumentation – Schutzleiteranschluss, Strombelastbarkeit

VX25 Enclosure System – Technical documentation – PE conductor connection, current carrying capacity

Armoires électriques VX25 – Manuel technique – Raccordement de mise à la terre et intensités maximales admissibles

DE EN FR

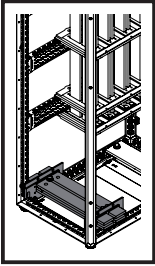

## 2. Montage Hochführungsfeld

## 2. Fitting the riser section

## 2. Montage de zone d'installation verticale

- 2.10 Montage des N-Sammelschienensystems
- 2.10 Fitting the N busbar system
- 2.10 Montage des jeux de barres Neutre

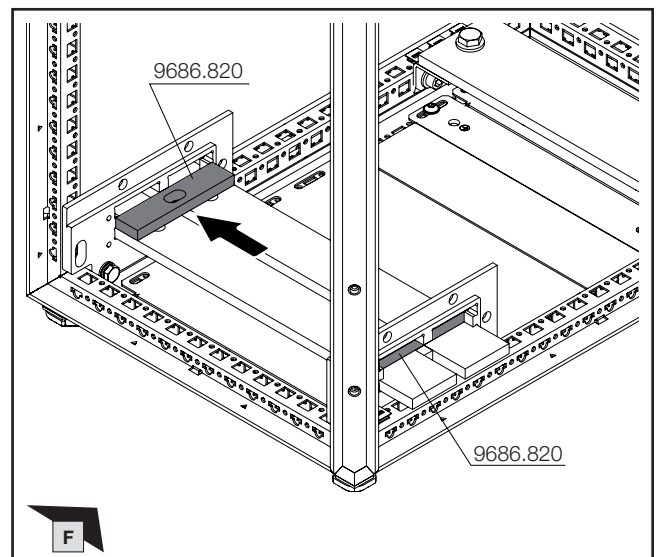
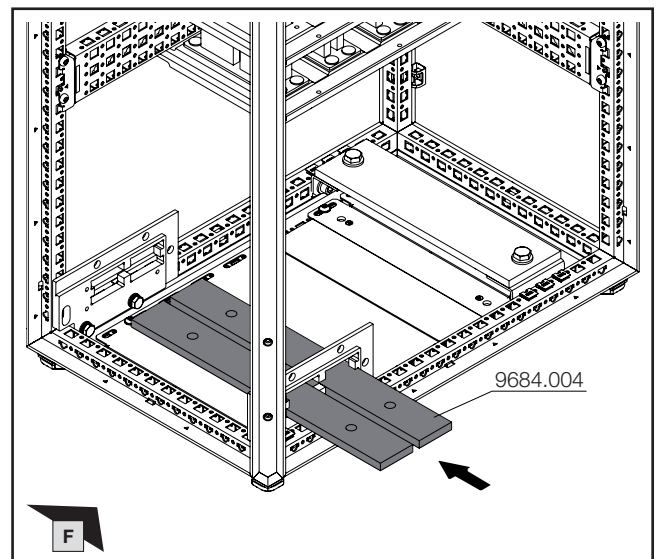
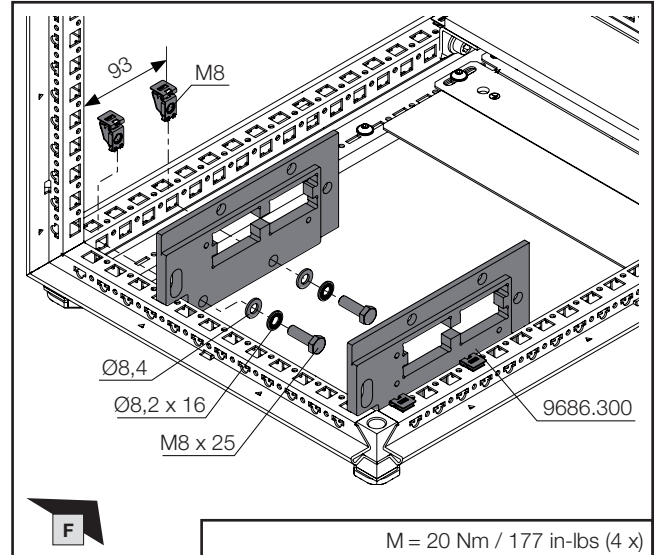
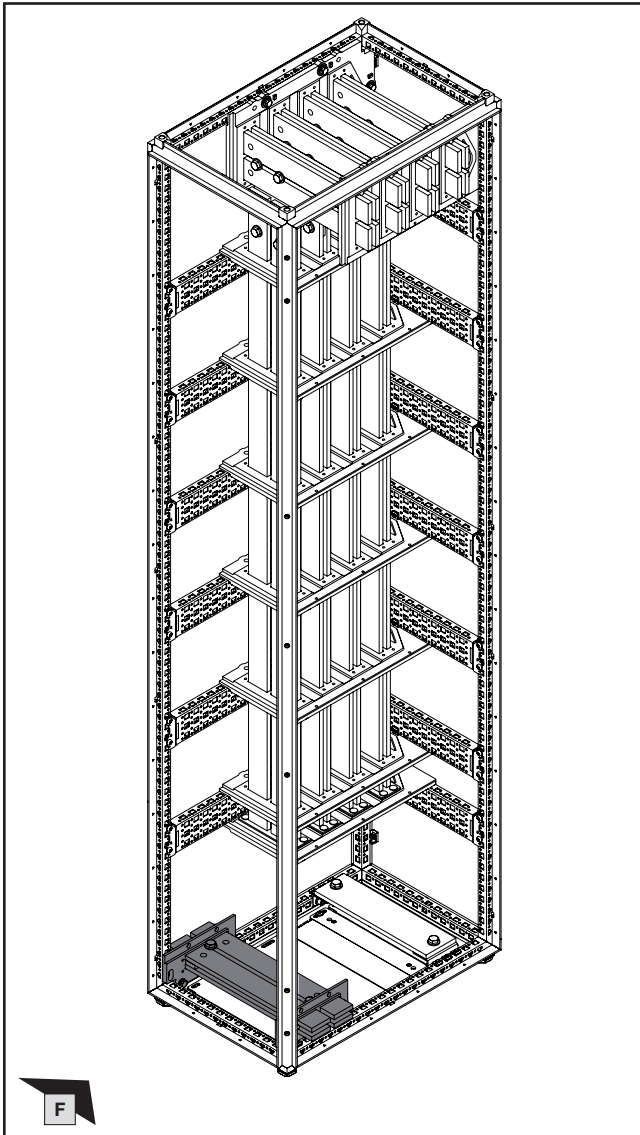

Montageanleitung VX25 Ri4Power – Schalt- und Energieverteilanlagen-System  
Assembly instructions VX25 Ri4Power – Switchgear and power distribution system  
Notice de montage VX25 Ri4Power – Distribution de courant

DE/EN/FR

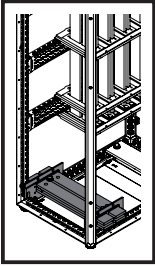

SW16/  
SW17



2. Montage Hochführungsfeld  
 2. Fitting the riser section  
 2. Montage de zone d'installation verticale

- 2.10 Montage des N-Sammelschienensystems
- 2.10 Fitting the N busbar system
- 2.10 Montage des jeux de barres Neutre

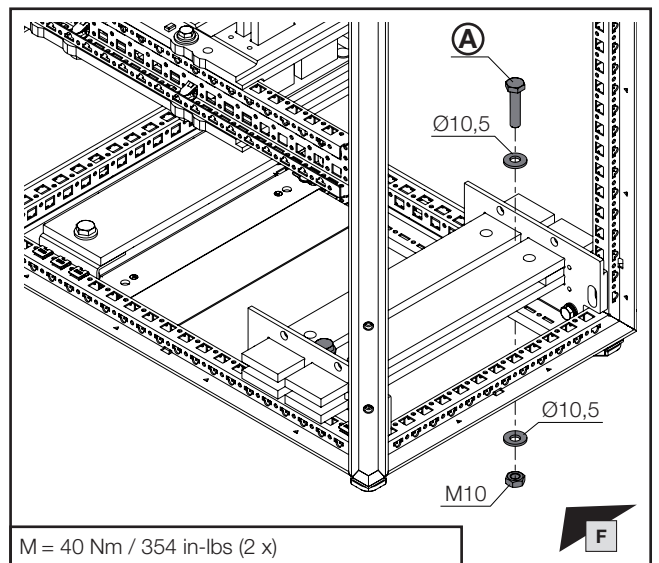
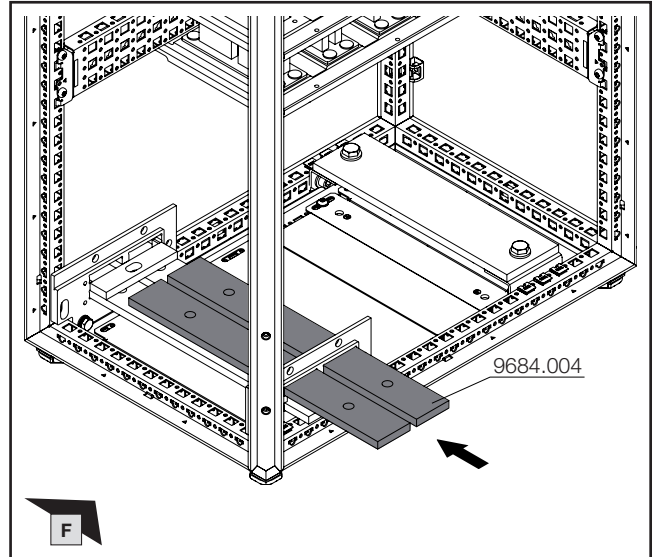
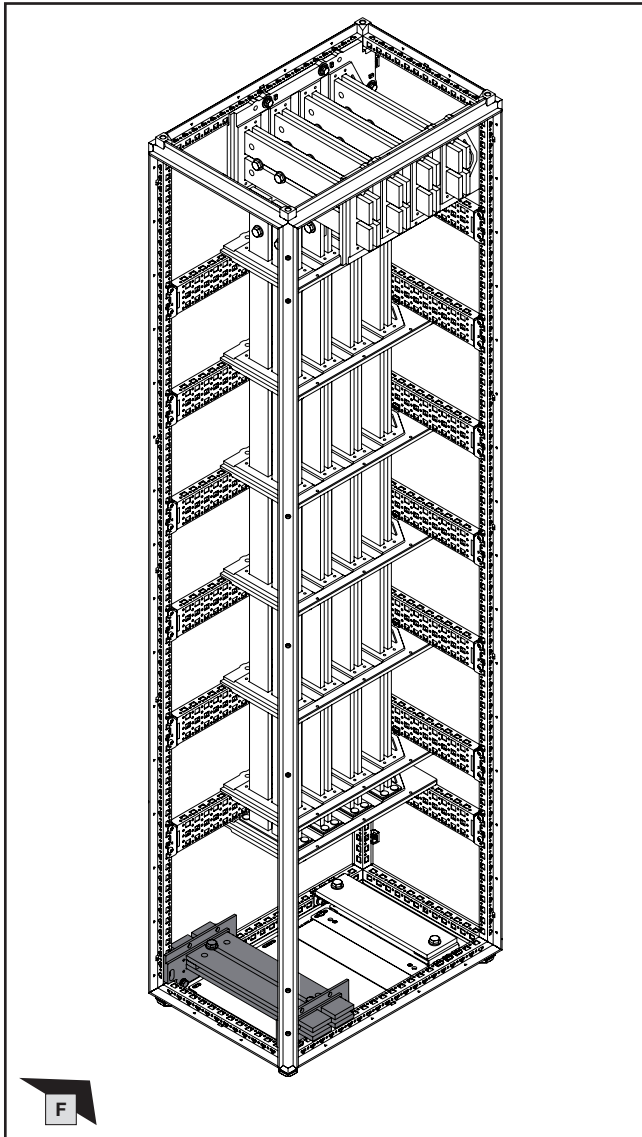

Anzahl N-Sammelschienen Quantity N busbars Nombre des jeux de barres Neutre	(A) Best.-Nr. Model No. Référence
2	9686.830
4	9686.845

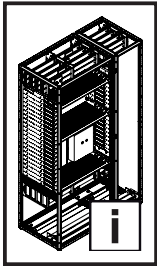

### 3. Verbindung ACB- und Hochführungsfeld

### 3. Connecting the air circuit-breaker (ACB) and riser section

### 3. Connexion du disjoncteur de puissance et de la zone d'installation verticale

- 3.1 Verbindung des ACB- und des Hochführungsfelds  
 3.1 Connecting the ACB and riser section  
 3.1 Connexion du disjoncteur de puissance et de la zone d'installation verticale

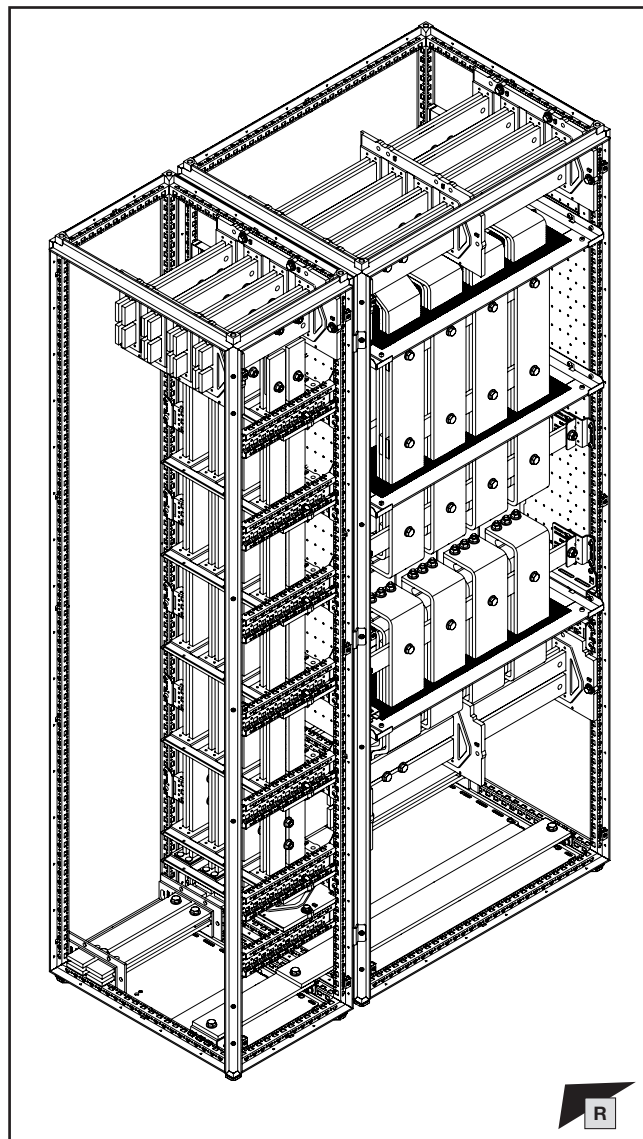
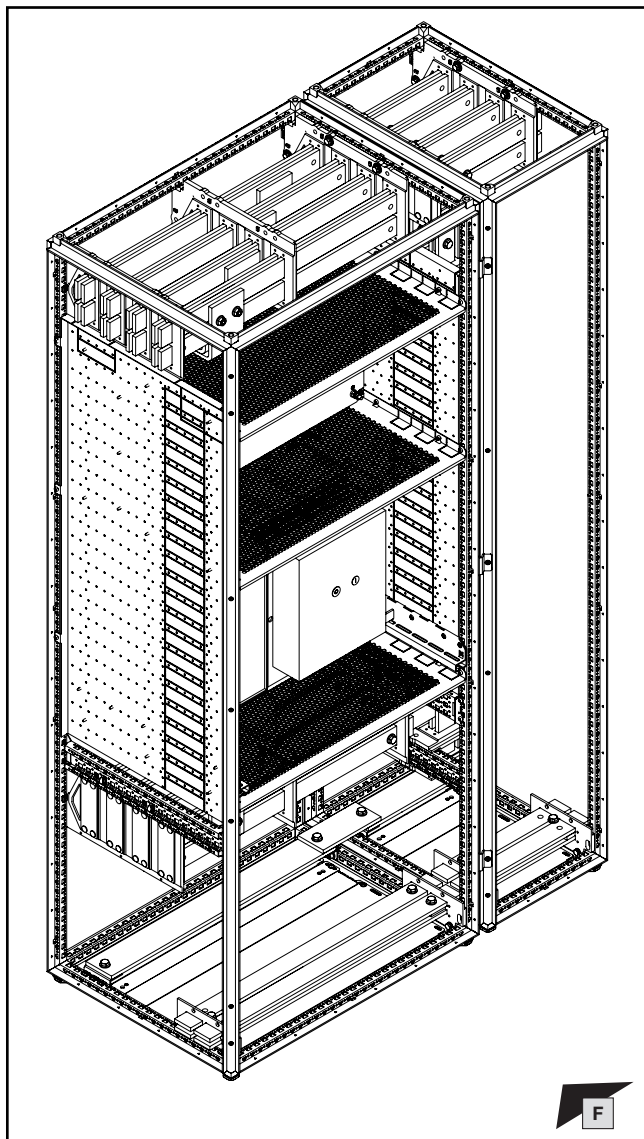

#### Hinweis / Note / Remarque

Der weitere Aufbau der Schaltanlage entspricht einer prinzipiellen Montagereihenfolge in der Werkstatt. Für das Aufstellen/Verbinden der Anlagenfelder bei Kapitel 4.1 weiter fortfahren.

Subsequent switchgear assembly follows the general assembly sequence in the workshop. Continue with chapter 4.1 on positioning and connecting the system sections.

La suite du montage de l'installation de distribution électrique est conforme à l'ordre de montage habituel à l'atelier. Poursuivre au chapitre 4.1 pour l'installation / la connexion des zones.

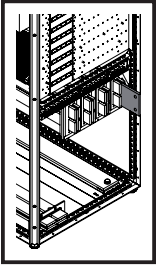

SW16/  
SW17



**3. Verbindung ACB- und Hochführungsfeld**  
**3. Connecting the air circuit-breaker (ACB) and riser section**  
**3. Connexion du disjoncteur de puissance et de la zone d'installation verticale**

- 3.2 Vorbereitung Sammelschienensystem – Einführen der Längsverbinder
- 3.2 Preparing the busbar system – Inserting the longitudinal connectors
- 3.2 Préparation des jeux de barres – introduction des éléments de jonction longitudinaux

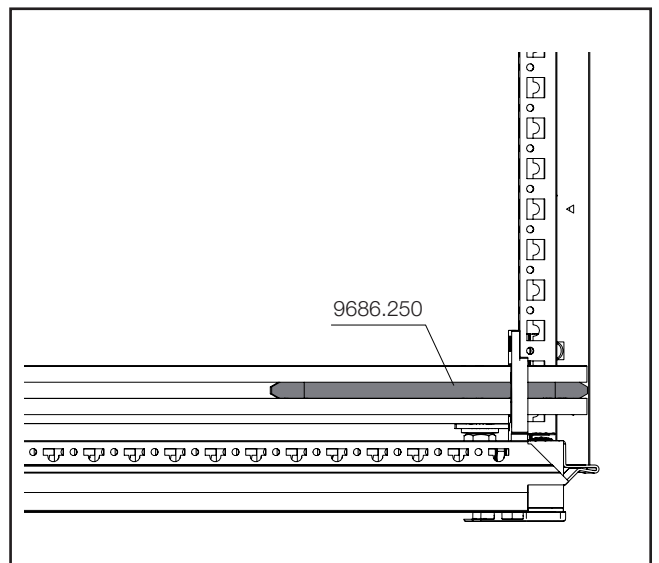
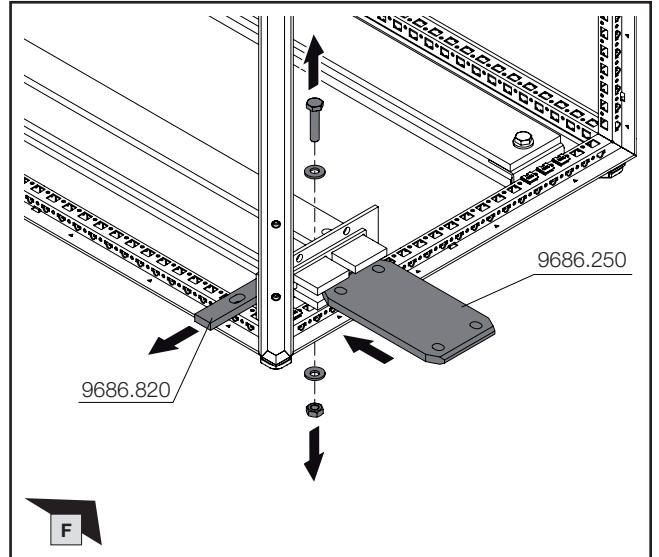
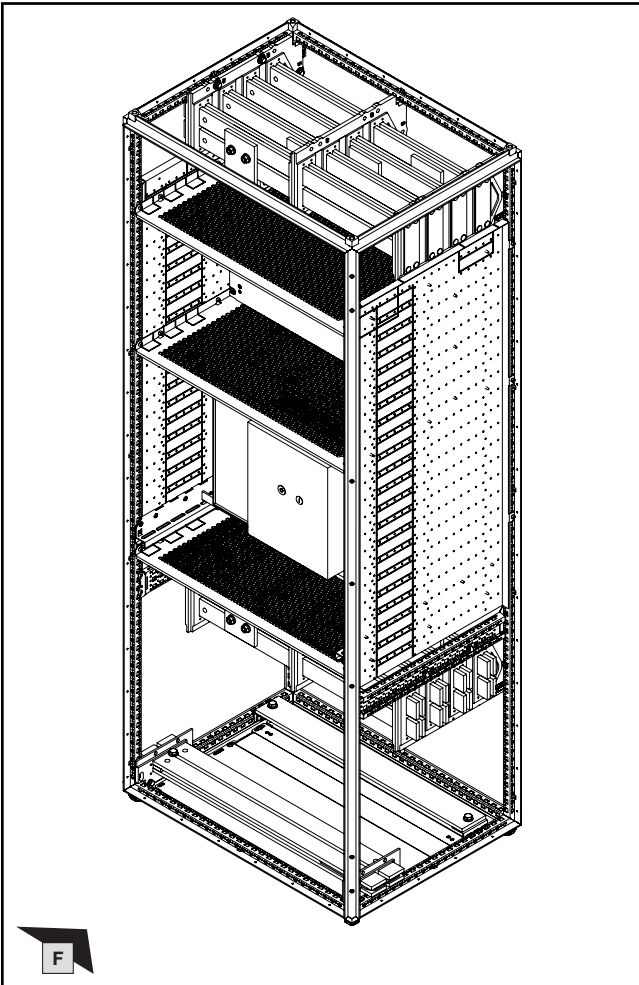

**Hinweis / Note / Remarque (X)**

Die Länge der Längsverbinder L1 bis L3 wird mit Hilfe der Online-Berechnungssoftware „RiPower“ im Niederspannungsschaltanlagen Konfigurator ermittelt.  
 The length of the longitudinal connectors L1 to L3 is determined using the online calculation software "RiPower" in the low-voltage switchgear configurator.

La longueur des éléments de jonction longitudinaux L1 à L3 est déterminée à l'aide du logiciel de calcul en ligne « VX25 Rittal Power Engineering » du configurateur de TGBT Ri4Power.



**RiPower**

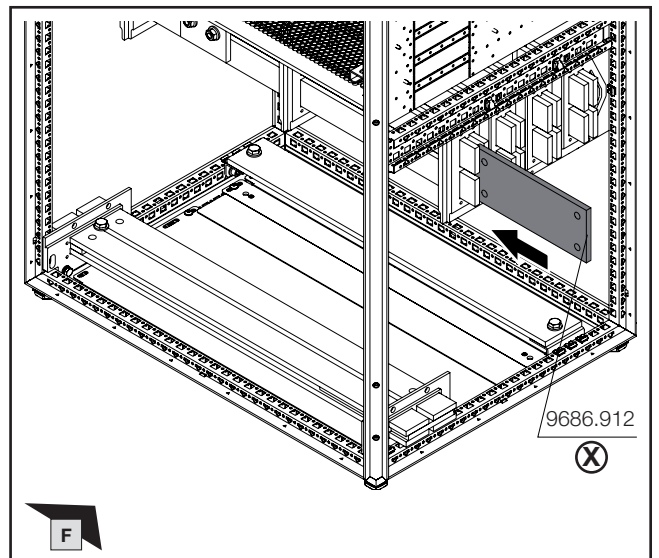

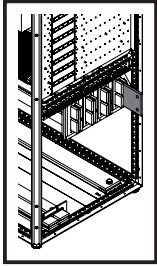

**3. Verbindung ACB- und Hochführungsfeld**  
**3. Connecting the air circuit-breaker (ACB) and riser section**  
**3. Connexion du disjoncteur de puissance et de la zone d'installation verticale**

- 3.2 Vorbereitung Sammelschienensystem – Einführen der Längsverbinder
- 3.2 Preparing the busbar system – Inserting the longitudinal connectors
- 3.2 Préparation des jeux de barres – introduction des éléments de jonction longitudinaux

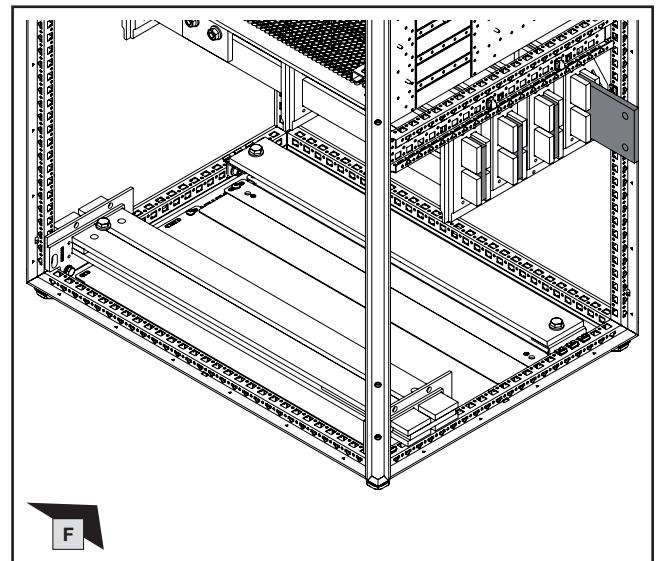
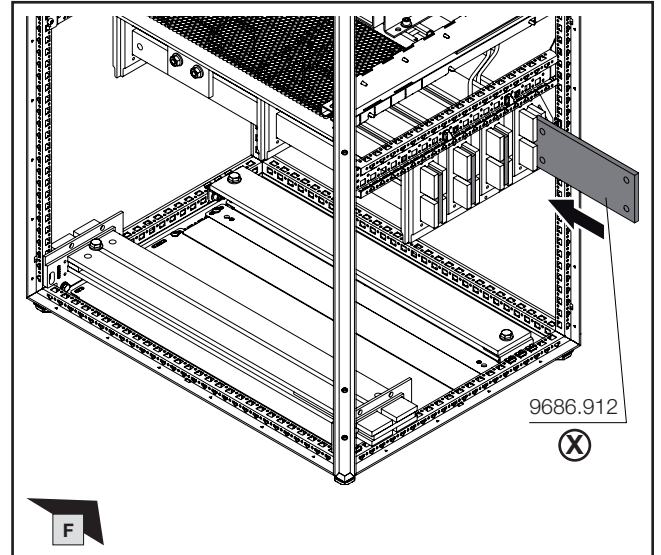
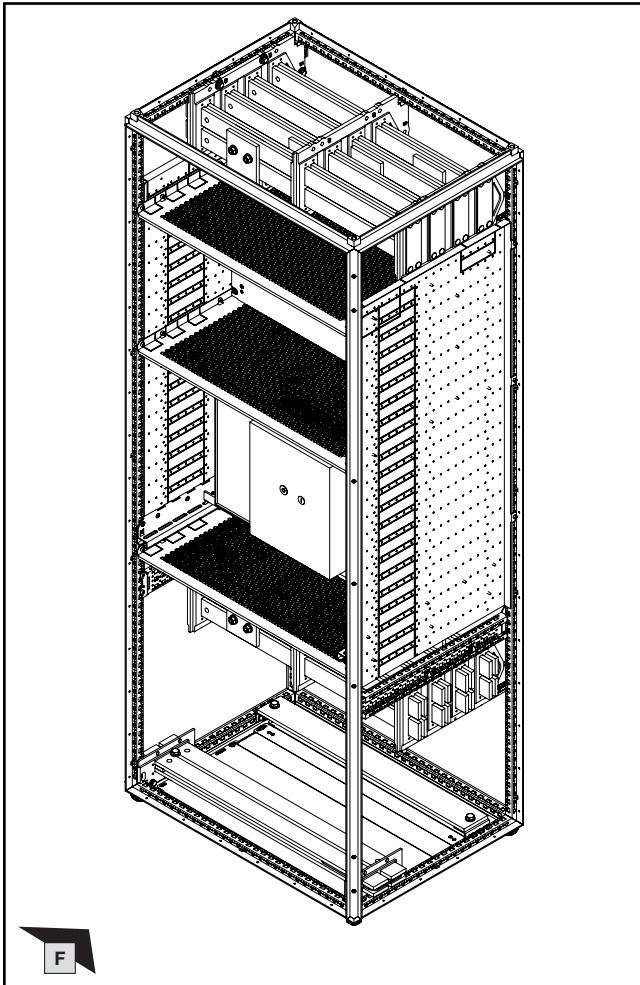

**Hinweis / Note / Remarque** (X)

Die Länge der Längsverbinder L1 bis L3 wird mit Hilfe der Online-Berechnungssoftware „RiPower“ im Niederspannungsschaltanlagen Konfigurator ermittelt.  
 The length of the longitudinal connectors L1 to L3 is determined using the online calculation software "RiPower" in the low-voltage switchgear configurator.

La longueur des éléments de jonction longitudinaux L1 à L3 est déterminée à l'aide du logiciel de calcul en ligne « VX25 Rittal Power Engineering » du configurateur de TGBT Ri4Power.



**RiPower**

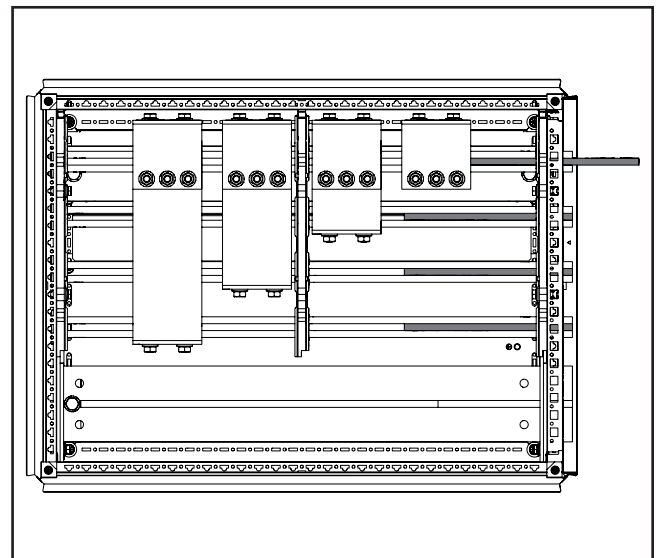

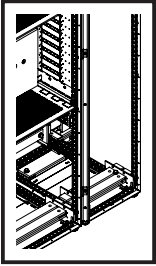

**3. Verbindung ACB- und Hochführungsfeld**  
**3. Connecting the air circuit-breaker (ACB) and riser section**  
**3. Connexion du disjoncteur de puissance et de la zone d'installation verticale**

- 3.3 Zusammenfügen der Schaltanlagenfelder – Montage der Anreihverbinder
- 3.3 Joining the switchgear sections together – Fitting the baying connectors
- 3.3 Assemblage des différentes cellules de distribution électrique – montage des attaches de juxtaposition

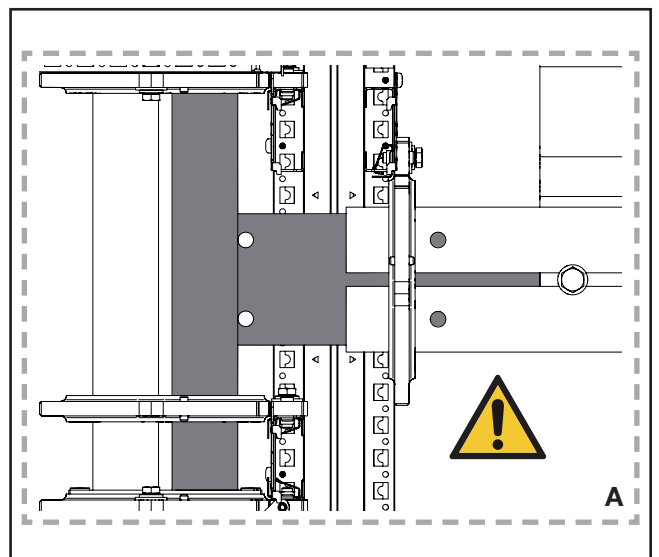
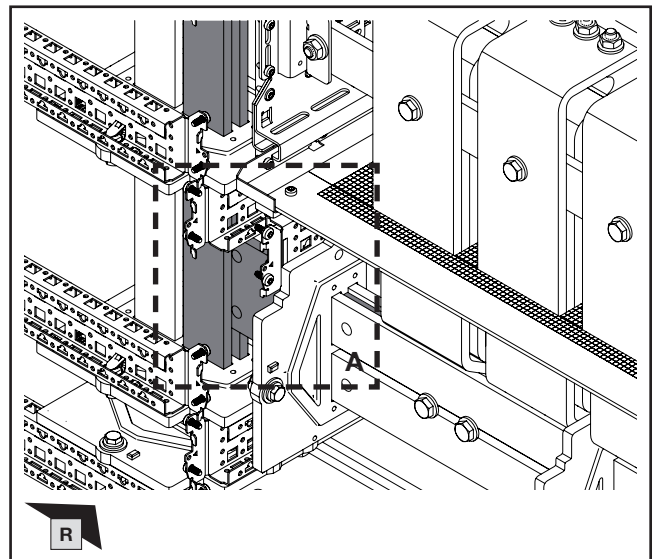
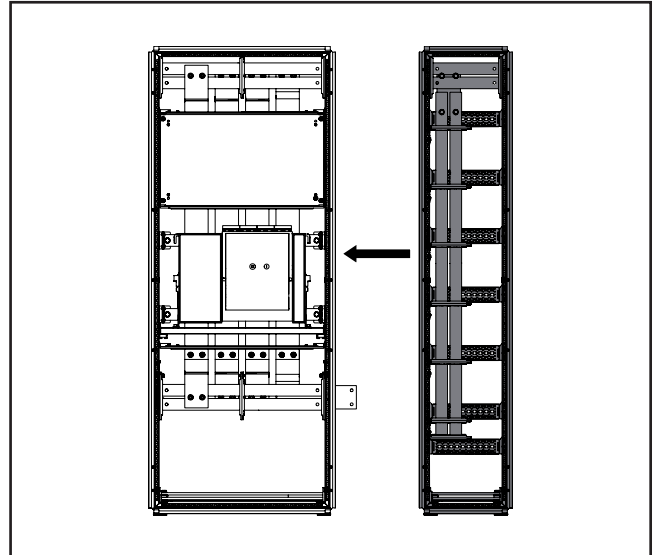
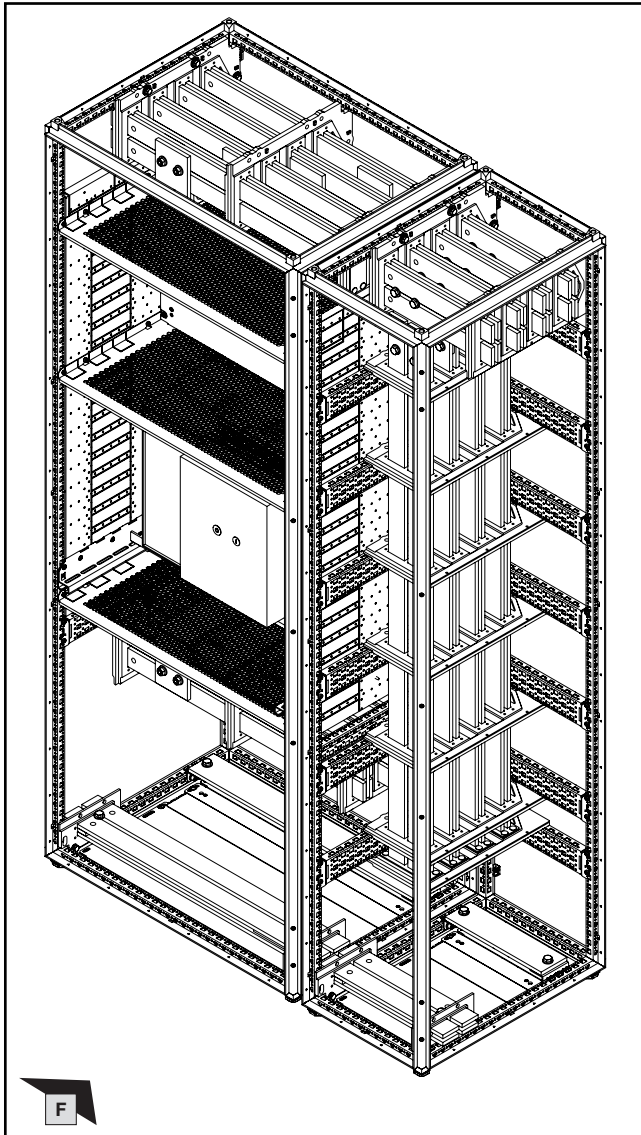

**Hinweis / Note / Remarque**

Beim Zusammenfügen der beiden Schaltanlagenfelder ggf. Schrauben lösen, um das Einschieben des Längsverbinders zu erleichtern. Ansonsten können die HSS-Systeme beschädigt werden.

When joining the two switchgear sections together, loosen the screws if necessary to make insertion of the longitudinal connector easier. Otherwise the MBS systems may be damaged.

Desserrer si nécessaire les vis pour faciliter l'insertion des éléments de jonction longitudinaux lors de l'assemblage des deux zones de distribution électrique. Les jeux de barres principaux pourraient sinon être endommagés.

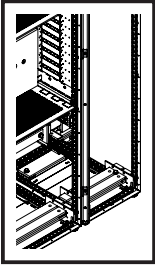

TX30



**3. Verbindung ACB- und Hochführungsfeld**  
**3. Connecting the air circuit-breaker (ACB) and riser section**  
**3. Connexion du disjoncteur de puissance et de la zone d'installation verticale**

- 3.3 Zusammenfügen der Schaltanlagenfelder – Montage der Anreihverbinder
- 3.3 Joining the switchgear sections together – Fitting the baying connectors
- 3.3 Assemblage des différentes cellules de distribution électrique – montage des attaches de juxtaposition

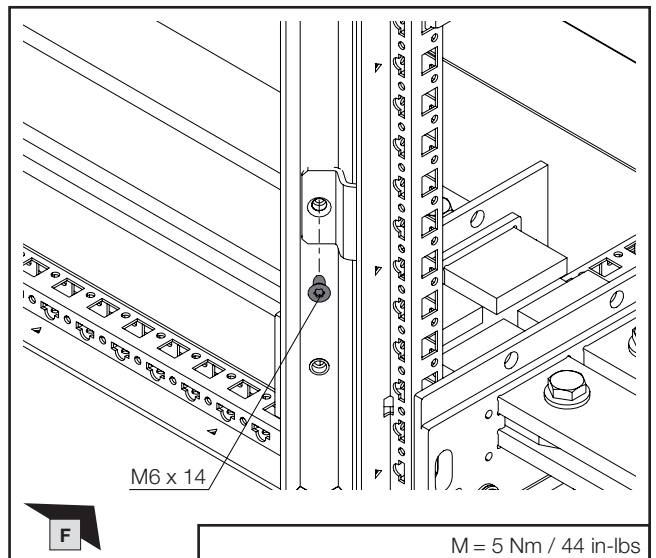
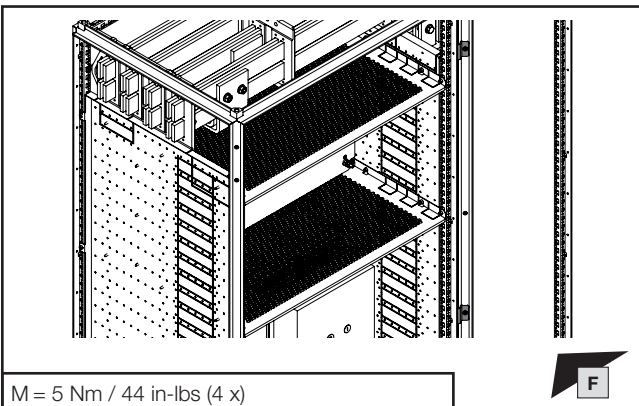
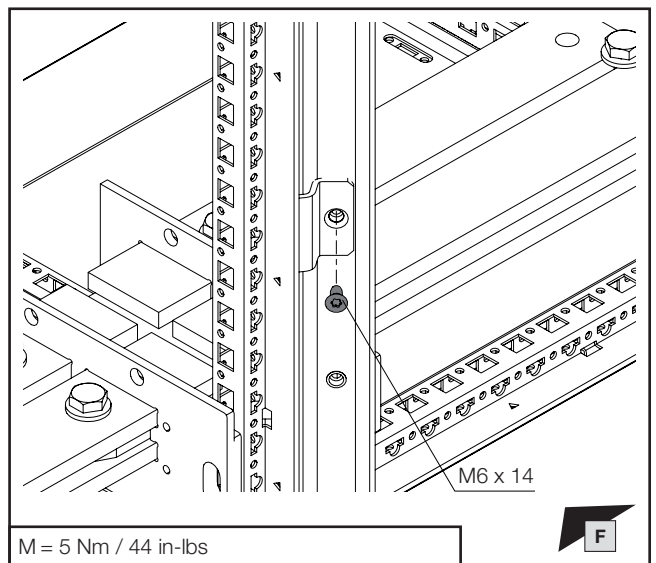
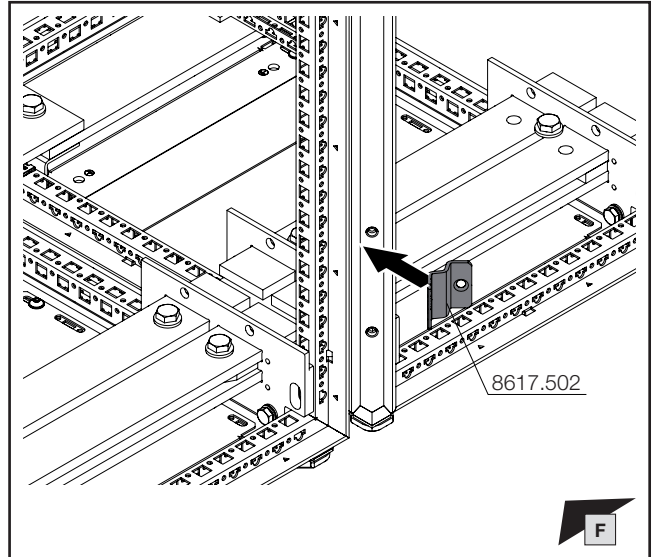
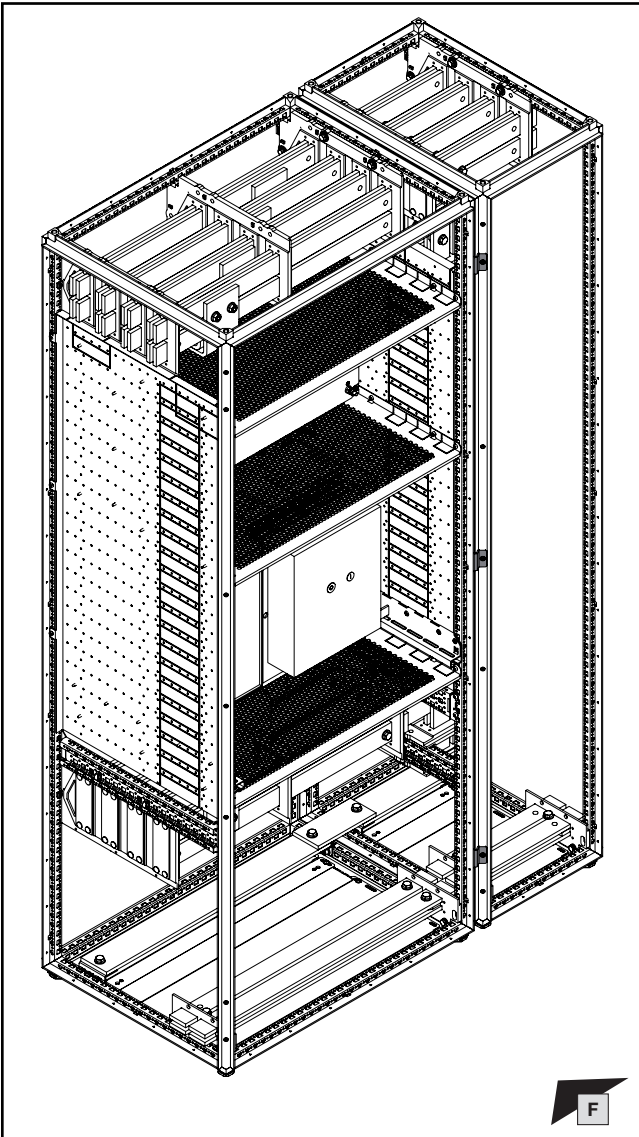

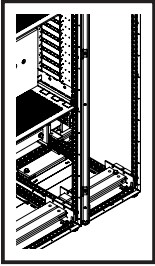

**TX30**



- 3. Verbindung ACB- und Hochführungsfeld**  
**3. Connecting the air circuit-breaker (ACB) and riser section**  
**3. Connexion du disjoncteur de puissance et de la zone d'installation verticale**

- 3.3 Zusammenfügen der Schaltanlagenfelder – Montage der Anreihverbinder  
 3.3 Joining the switchgear sections together – Fitting the baying connectors  
 3.3 Assemblage des différentes cellules de distribution électrique – montage des attaches de juxtaposition

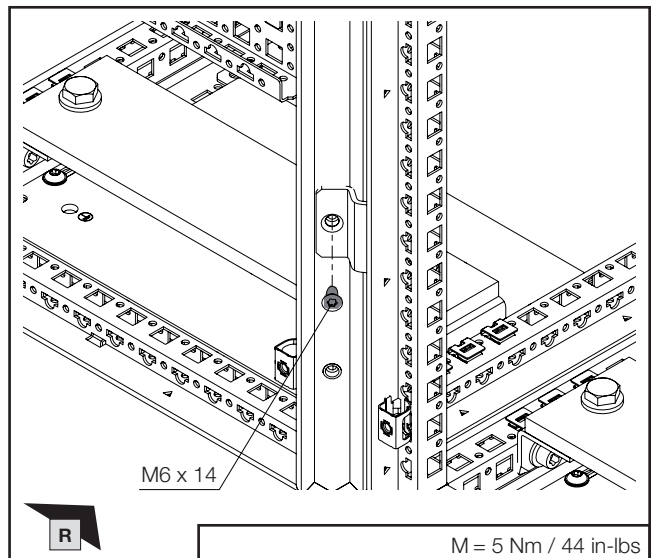
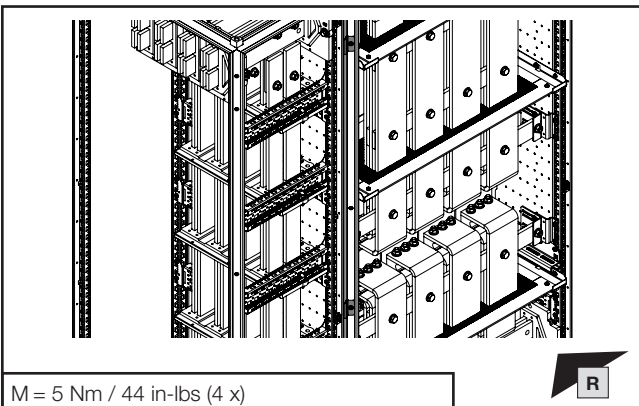
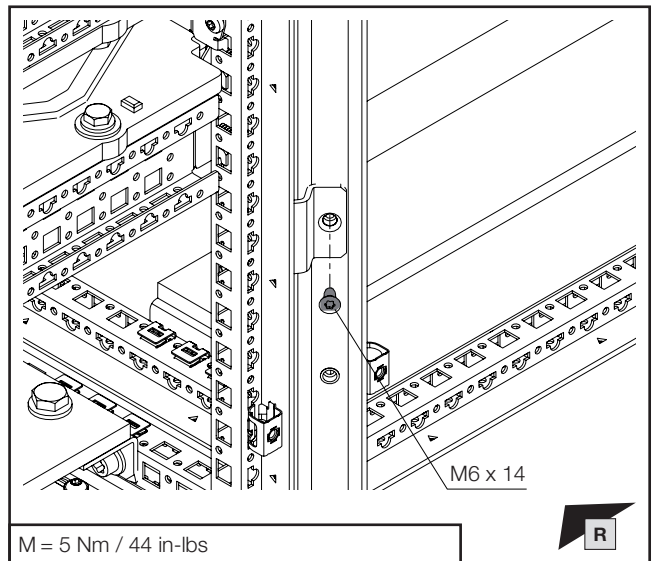
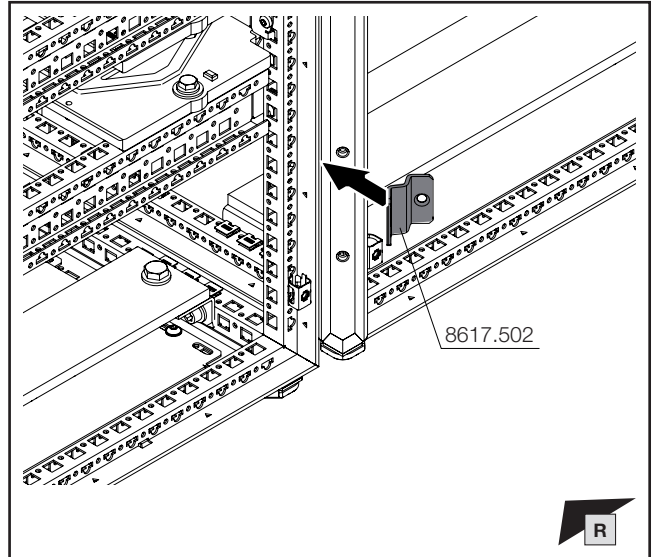
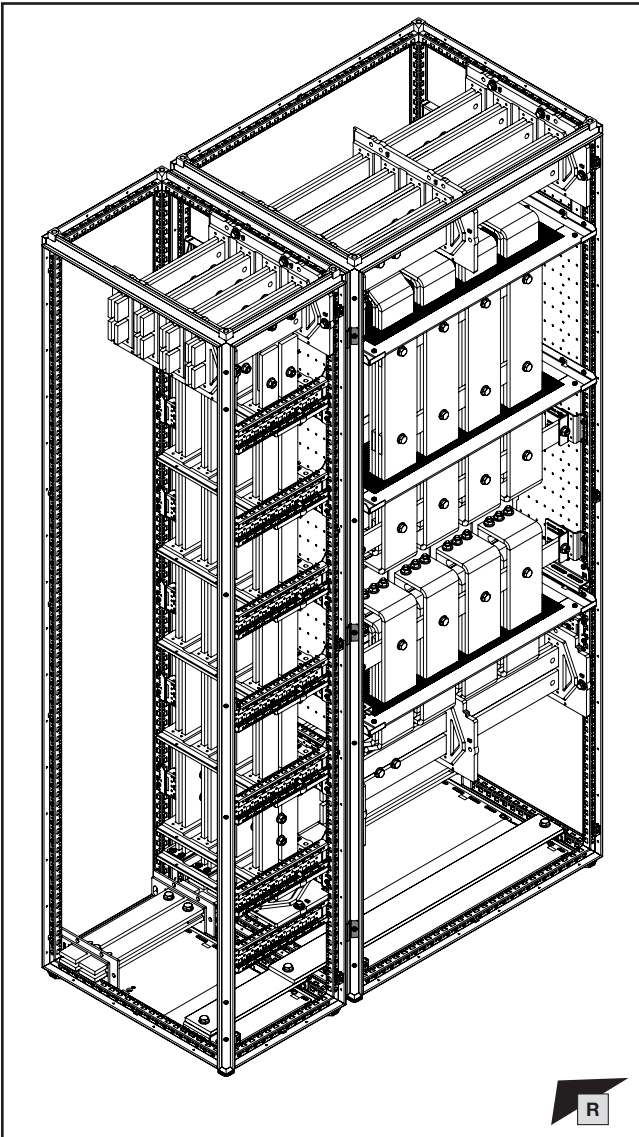

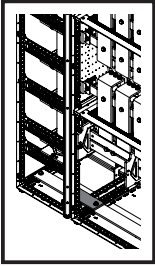

SW16/  
SW17

DE EN FR



3. Verbindung ACB- und Hochführungsfeld
3. Connecting the air circuit-breaker (ACB) and riser section
3. Connexion du disjoncteur de puissance et de la zone d'installation verticale

- 3.4 Verschrauben der Längsverbinder
- 3.4 Screw-fastening the longitudinal connectors
- 3.4 Vissage des éléments de jonction longitudinaux

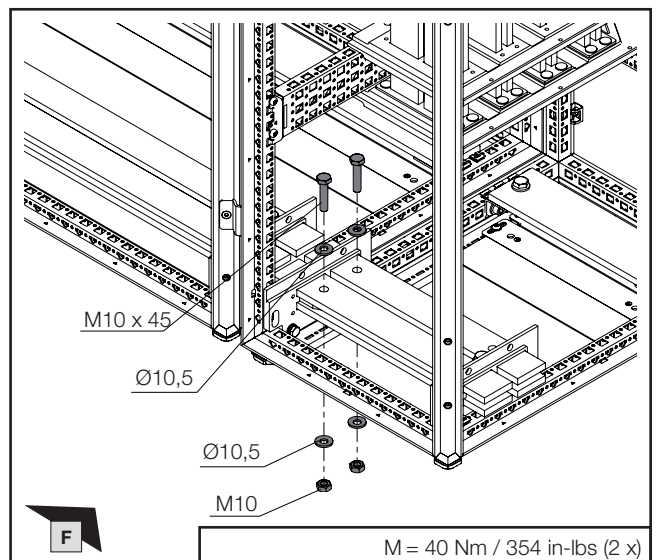
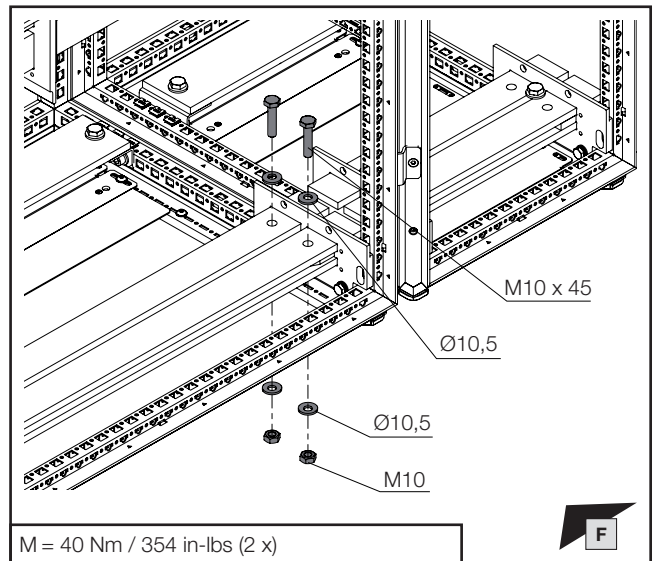
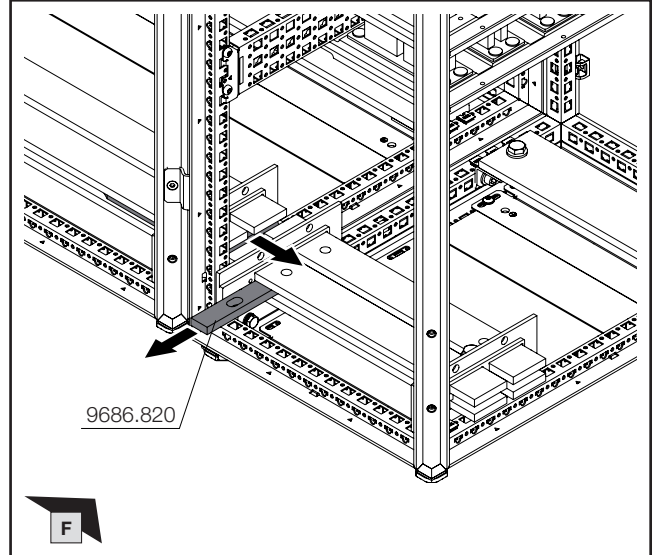
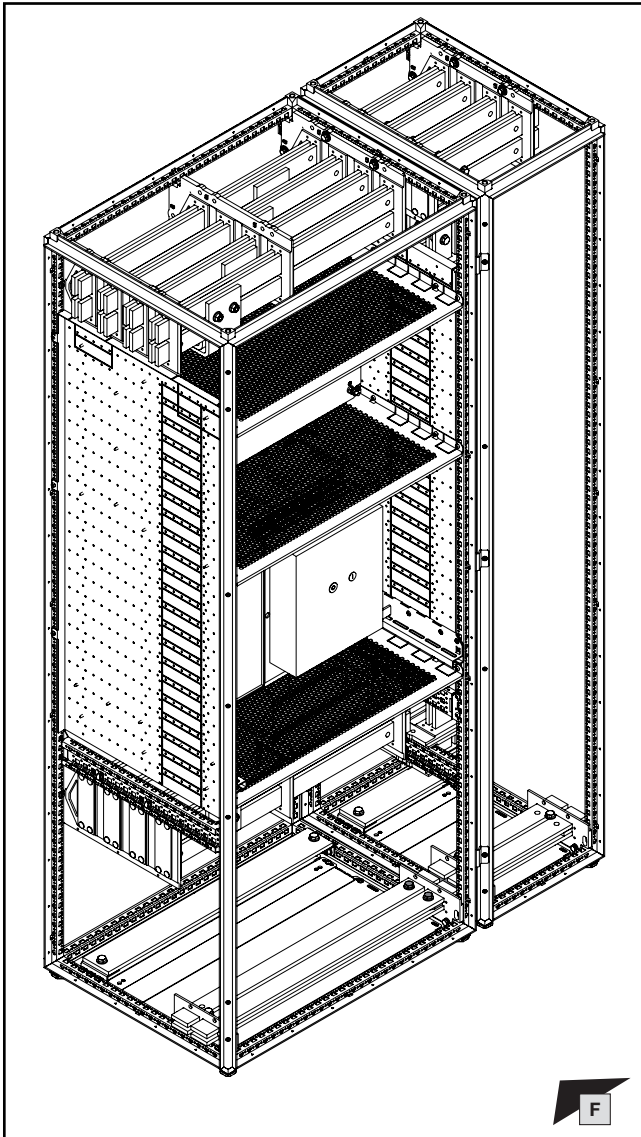

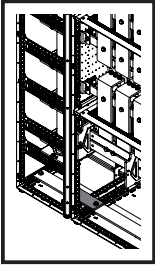

SW16/  
SW17 

DE EN FR



3. Verbindung ACB- und Hochführungsfeld
3. Connecting the air circuit-breaker (ACB) and riser section
3. Connexion du disjoncteur de puissance et de la zone d'installation verticale

- 3.4 Verschrauben der Längsverbinder
- 3.4 Screw-fastening the longitudinal connectors
- 3.4 Vissage des éléments de jonction longitudinaux

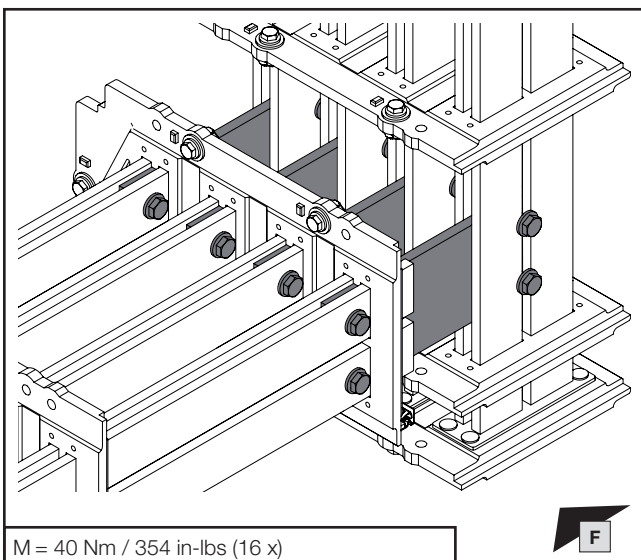
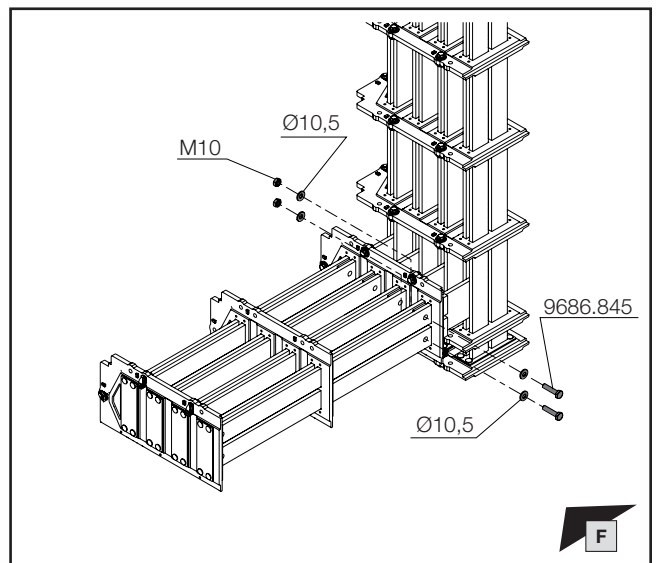
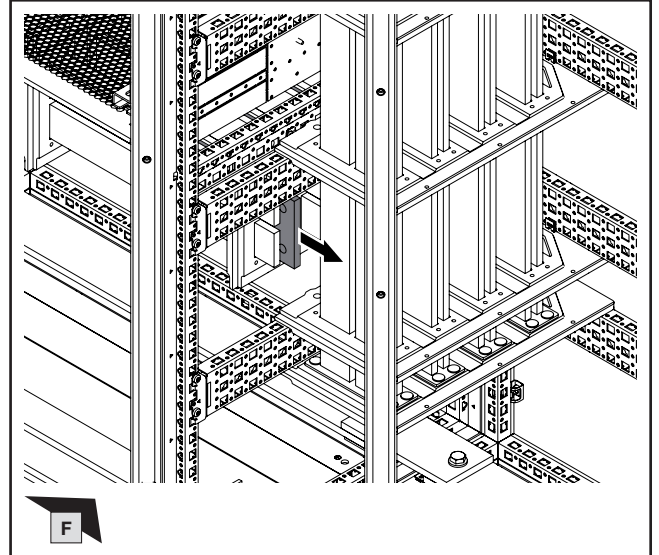
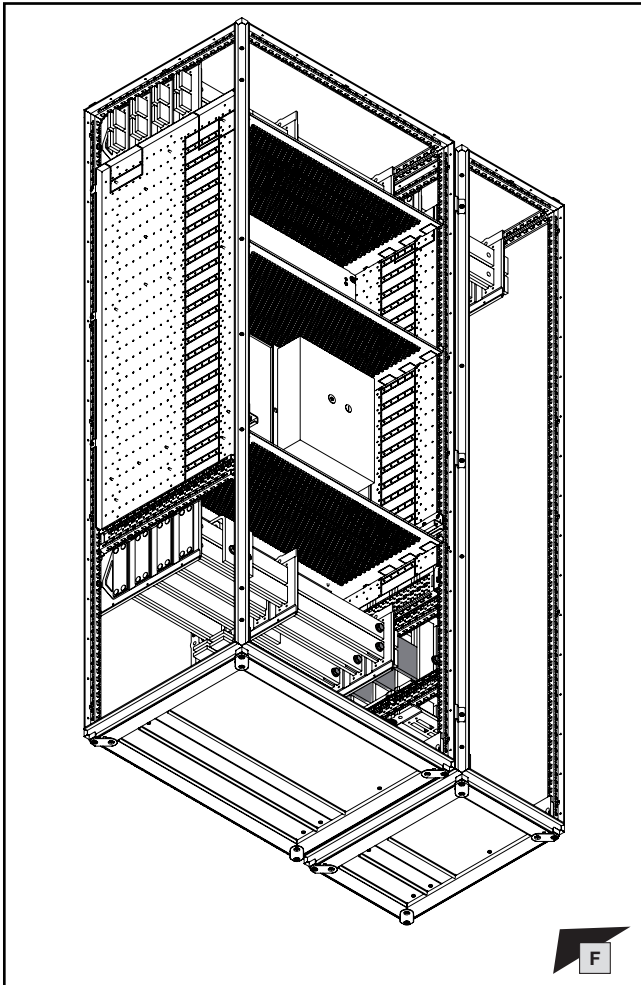

M = 40 Nm / 354 in-lbs (16 x)

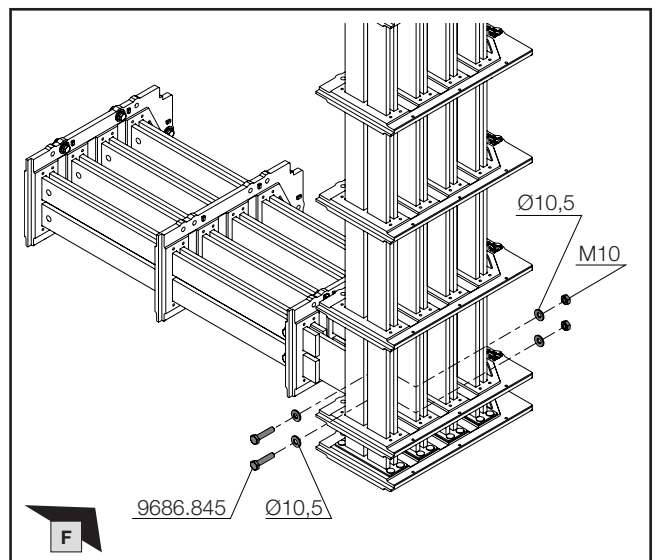

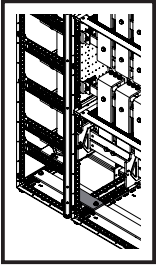

SW16/  
SW17

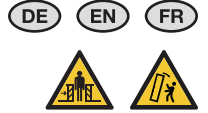

3. Verbindung ACB- und Hochführungsfeld  
 3. Connecting the air circuit-breaker (ACB) and riser section  
 3. Connexion du disjoncteur de puissance et de la zone d'installation verticale

- 3.4 Verschrauben der Längsverbinder  
 3.4 Screw-fastening the longitudinal connectors  
 3.4 Vissage des éléments de jonction longitudinaux

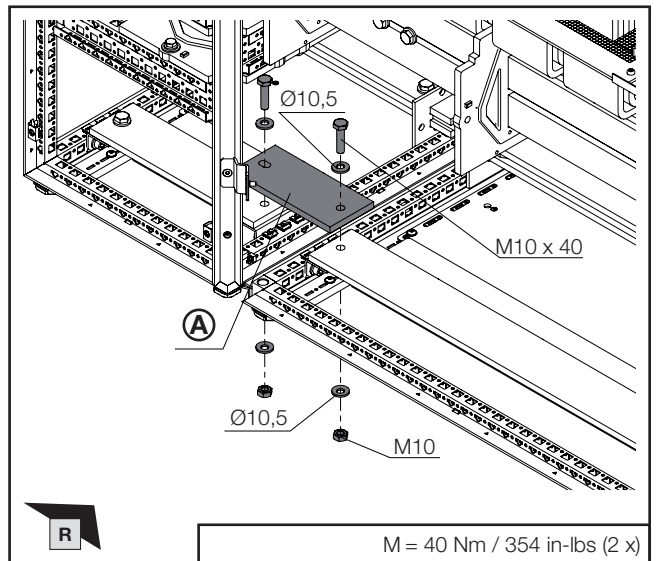
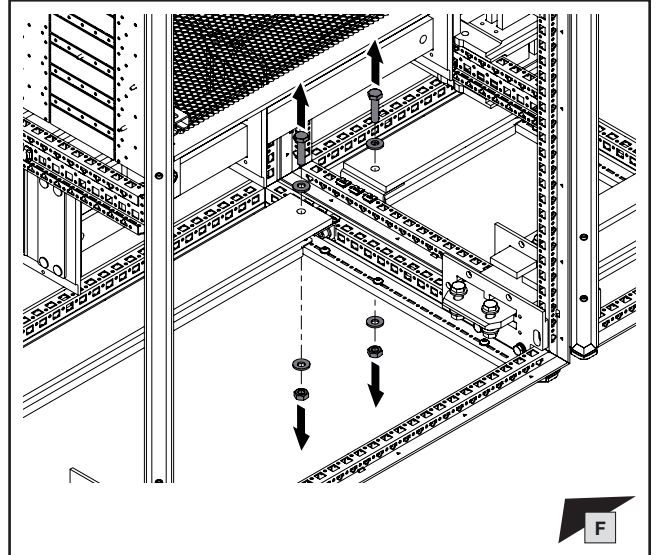
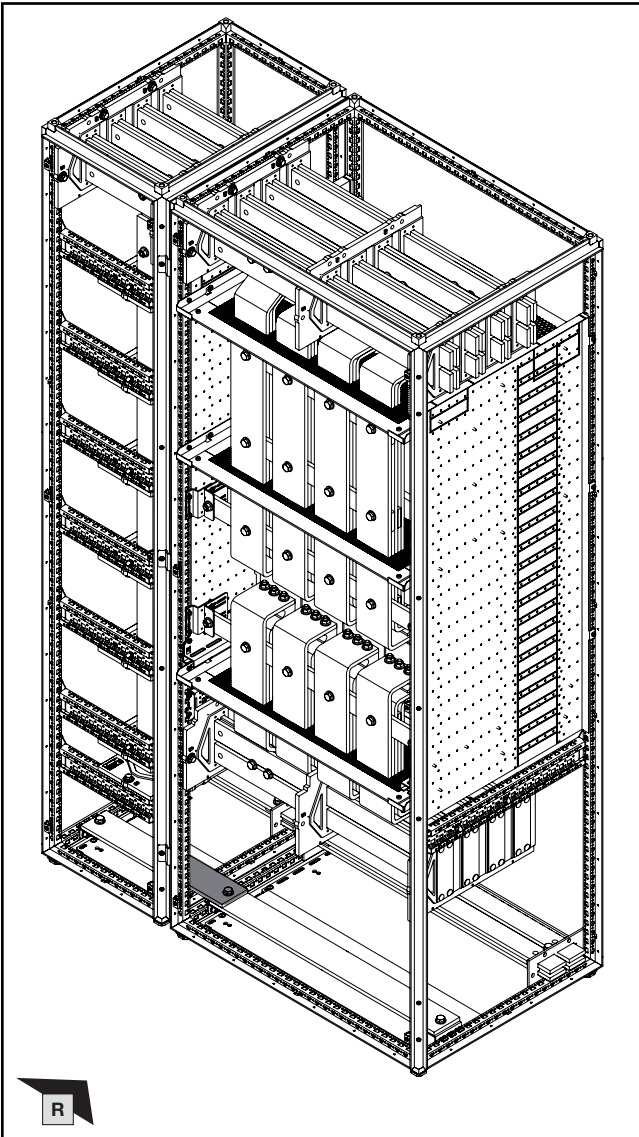

Abmessungen mm Dimensions mm Dimensions mm	Ⓐ Best.-Nr. Model No. Référence
30 x 5	9686.529
30 x 10	9686.539
40 x 10	9686.549
80 x 10	9686.589

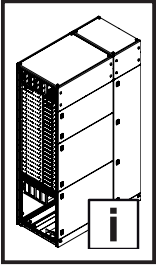

## 4. Modulare Frontgestaltung

### 4. Modular front design

### 4. Aménagement modulaire de la face avant

- 4.1 Montage Frontblenden, Teiltüren, Dachbleche und Rückwände
- 4.1 Fitting the front panels, partial doors, roof panels and rear panels
- 4.1 Montage des bandeaux de finition avant, portes partielles, toits et panneaux arrière

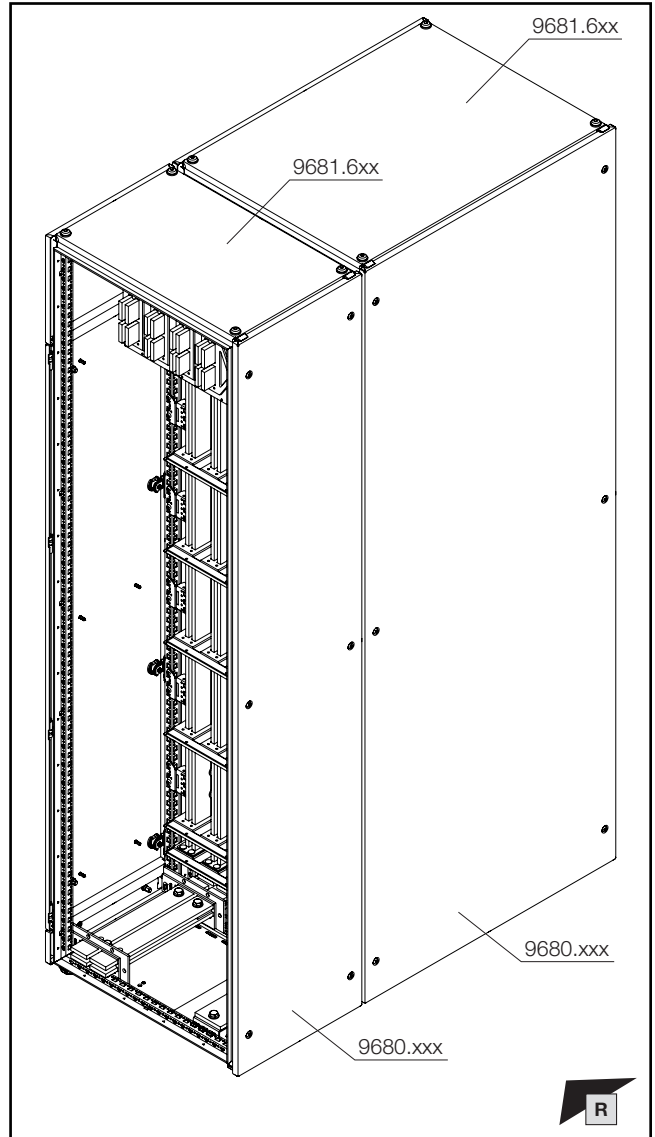
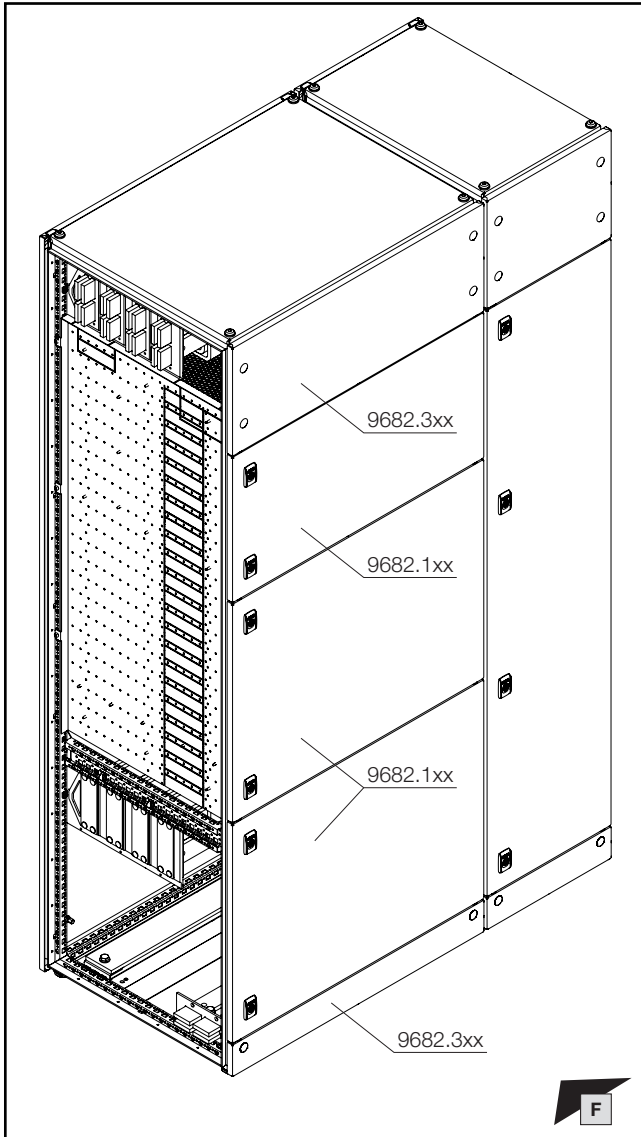

#### Hinweis / Note / Remarque

Beachten Sie für die abschließenden Arbeiten (Montage Flachteile, Frontgestaltung) je nach verwendetem Schrank die Beschreibungen in folgenden Anleitungen.

For the final work (fitting the panels, designing the front), please refer to the descriptions in the following instructions, depending on the enclosure used.

Pour les travaux finaux (montage des pièces plates, aménagement de la face avant), veuillez tenir compte, en fonction de l'armoire utilisée, des indications dans les notices suivantes.

#### Anreih-Schranksystem VX25

#### Enclosure baying system VX25

#### Armoires juxtaposables VX25

 DE/EN/FR

#### Modulare Frontgestaltung VX25

#### Modular front design VX25

#### Aménagement modulaire de la face avant VX25

 DE/EN/FR

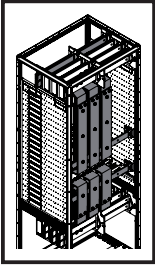

SW16/  
SW17

DE EN FR



5. Montage 3-poliges HSS  
5. Fitting the 3-pole MBS  
5. Montage des JBP tripolaires

- 5.1 Besonderheiten ACB-Feld
- 5.1 Special features – ACB section
- 5.1 Particularités – zone des disjoncteurs de puissance

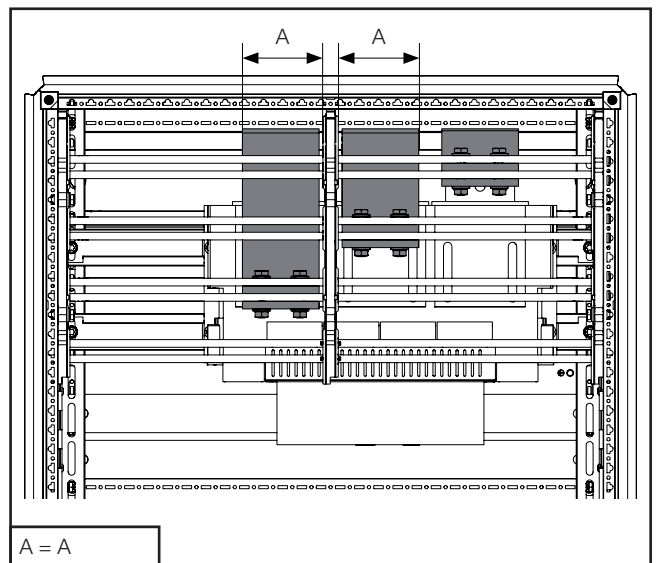
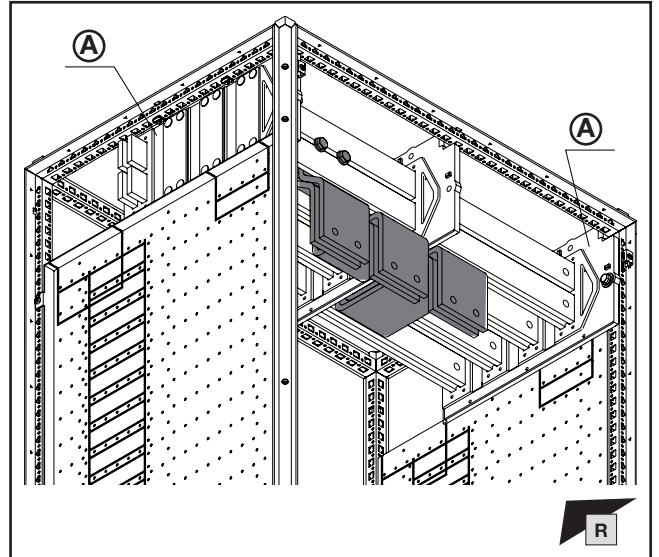
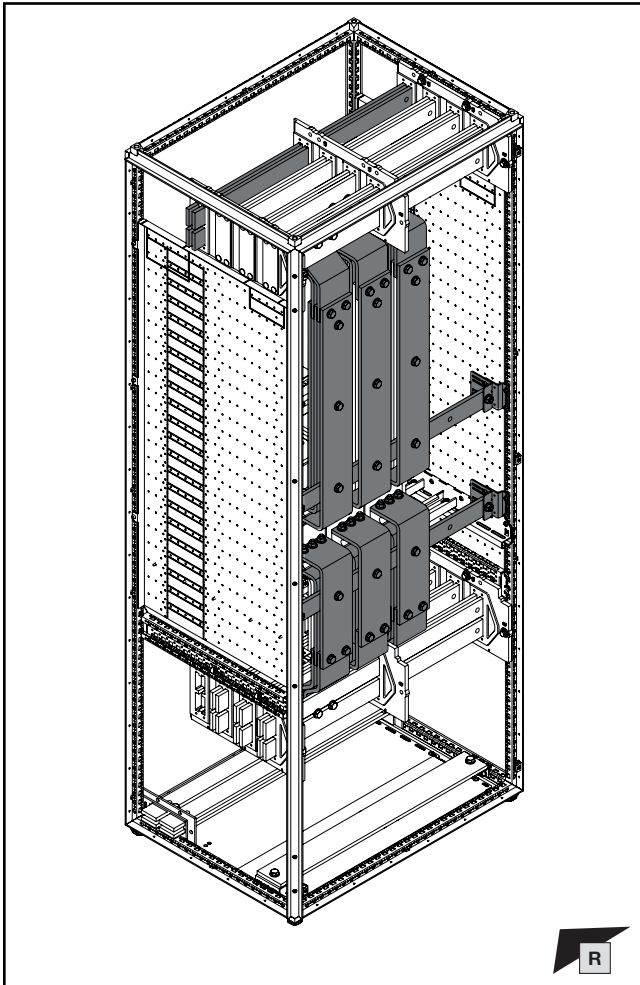

Sammelschiene Abmessung mm Busbar dimension mm Dimensions de la barre mm	Anreihung Baying Juxtaposition	(A) Best.-Nr. Model No. Référence
30 x 10	✓	9686.000
50 x 10	✓	9686.030



Hinweis / Note / Remarque

Dargestellt ist beispielhaft eine asymmetrische Positionierung des ACB im Feld, so dass L1 an der gleichen Position sitzt wie bei einem vierpoligen Hauptsammelschienenensystem.

The figure shows an example of asymmetrical positioning of the ACB in the section, so that L1 is located in the same position as in a four-pole main busbar system.

L'illustration montre un exemple de positionnement asymétrique du disjoncteur de puissance dans la cellule, de sorte que la phase L1 se trouve à la même position que dans les jeux de barres principaux à tétrapolaires.

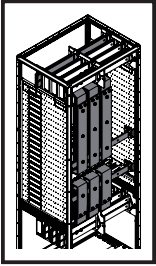

SW16/  
SW17



## 5. Montage 3-poliges HSS

## 5. Fitting the 3-pole MBS

## 5. Montage des JBP tripolaires

- 5.1 Besonderheiten ACB-Feld
- 5.1 Special features – ACB section
- 5.1 Particularités – zone des disjoncteurs de puissance

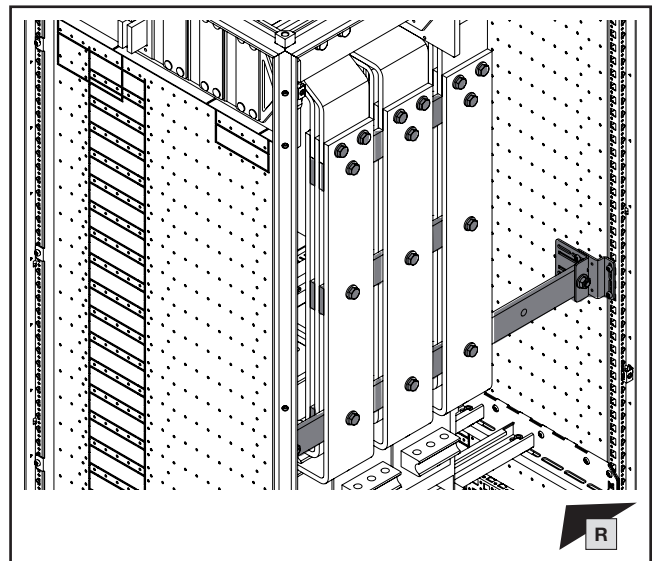
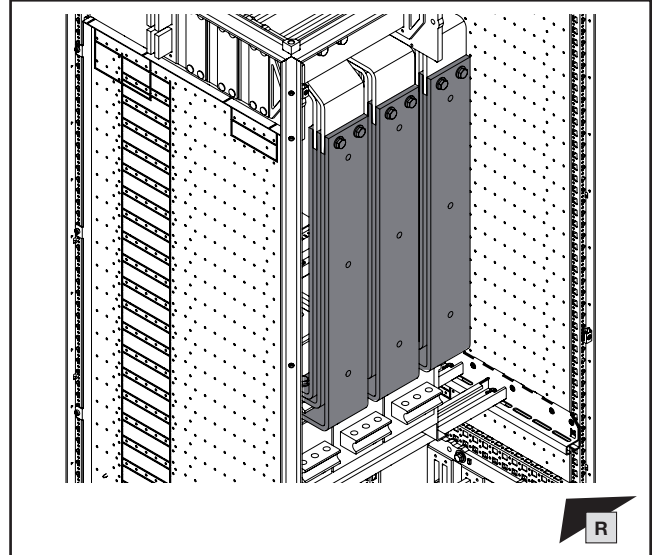
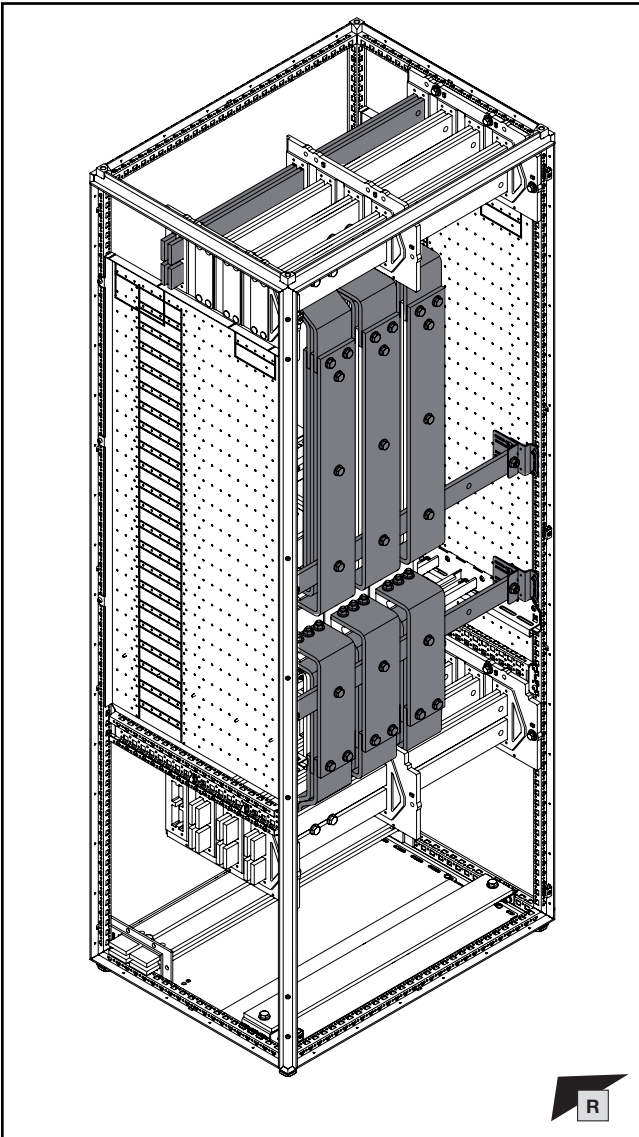

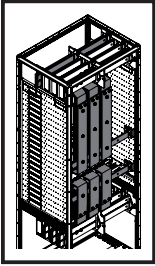

SW16/  
SW17

DE EN FR



## 5. Montage 3-poliges HSS

## 5. Fitting the 3-pole MBS

## 5. Montage des JBP tripolaires

- 5.1 Besonderheiten ACB-Feld
- 5.1 Special features – ACB section
- 5.1 Particularités – zone des disjoncteurs de puissance

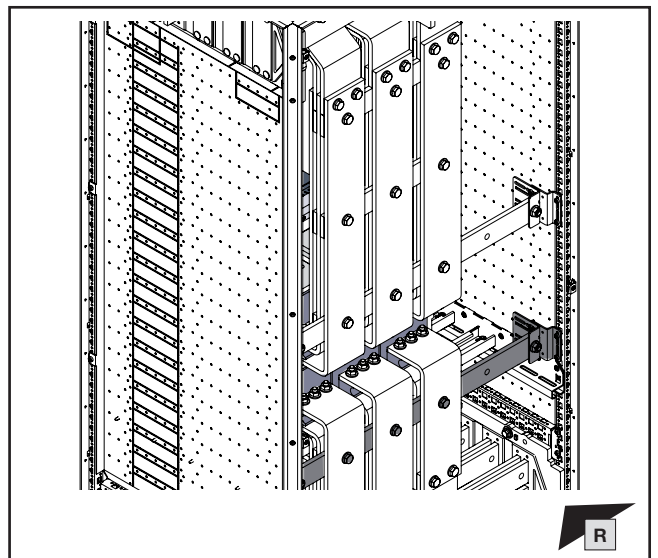
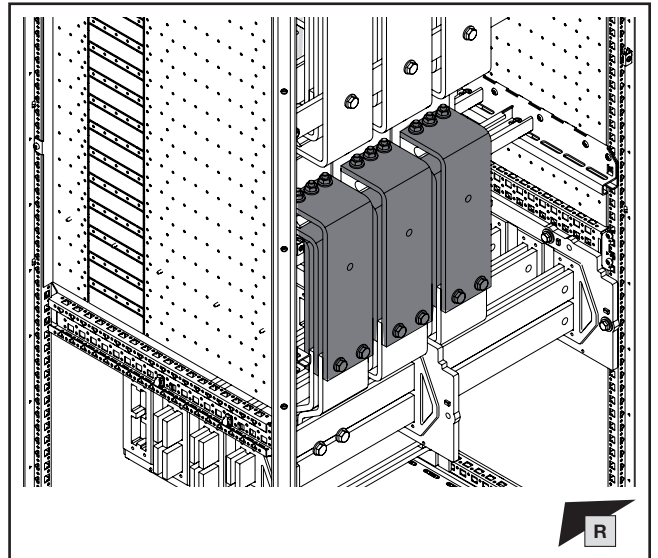
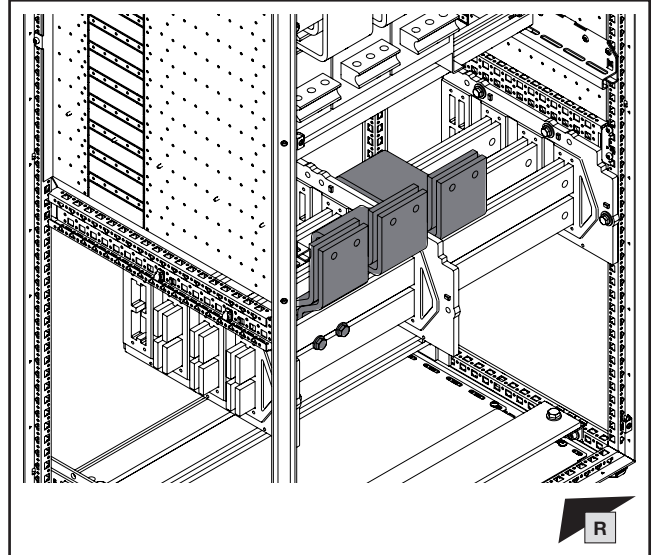
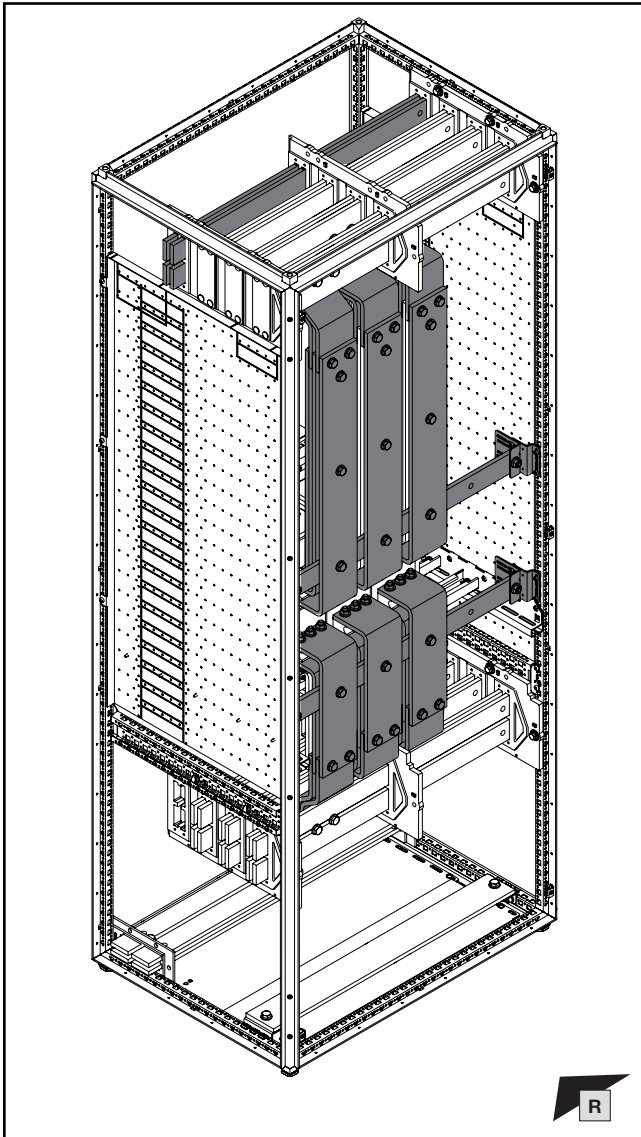

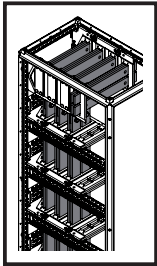

DE EN FR



**5. Montage 3-poliges HSS**  
**5. Fitting the 3-pole MBS**  
**5. Montage des JBP tripolaires**

- 5.2 Besonderheiten Hochführungsfeld
- 5.2 Special features – Riser section
- 5.2 Particularités – zone d'installation verticale

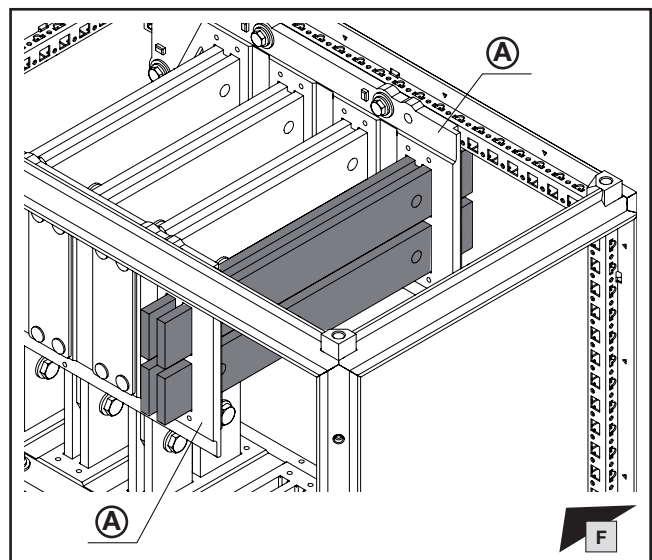
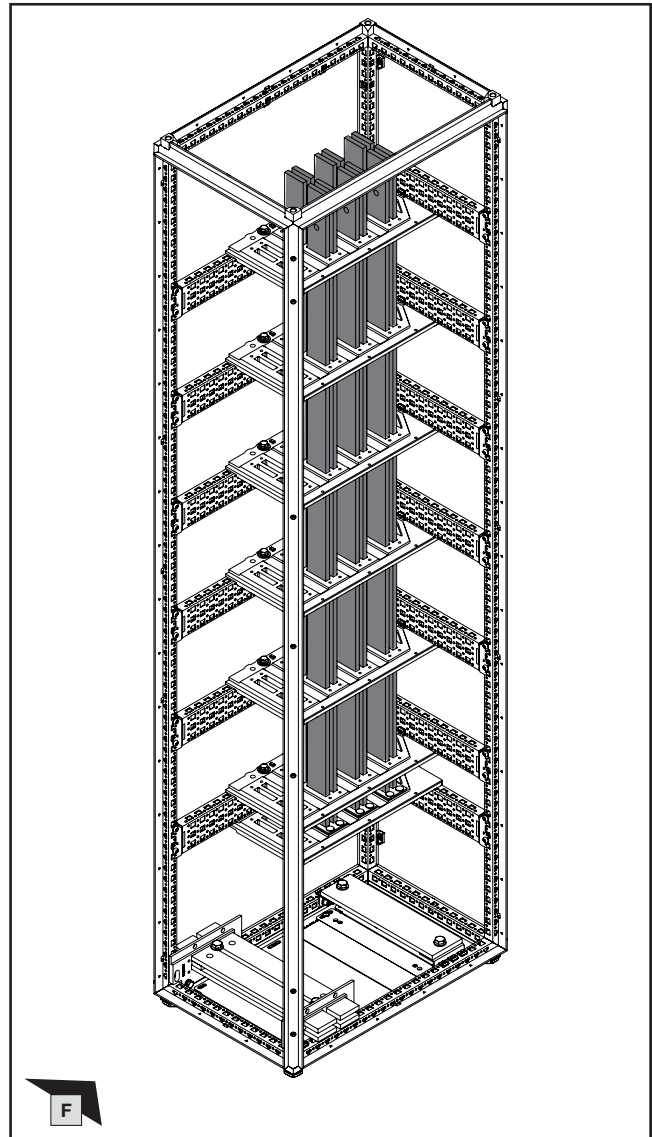
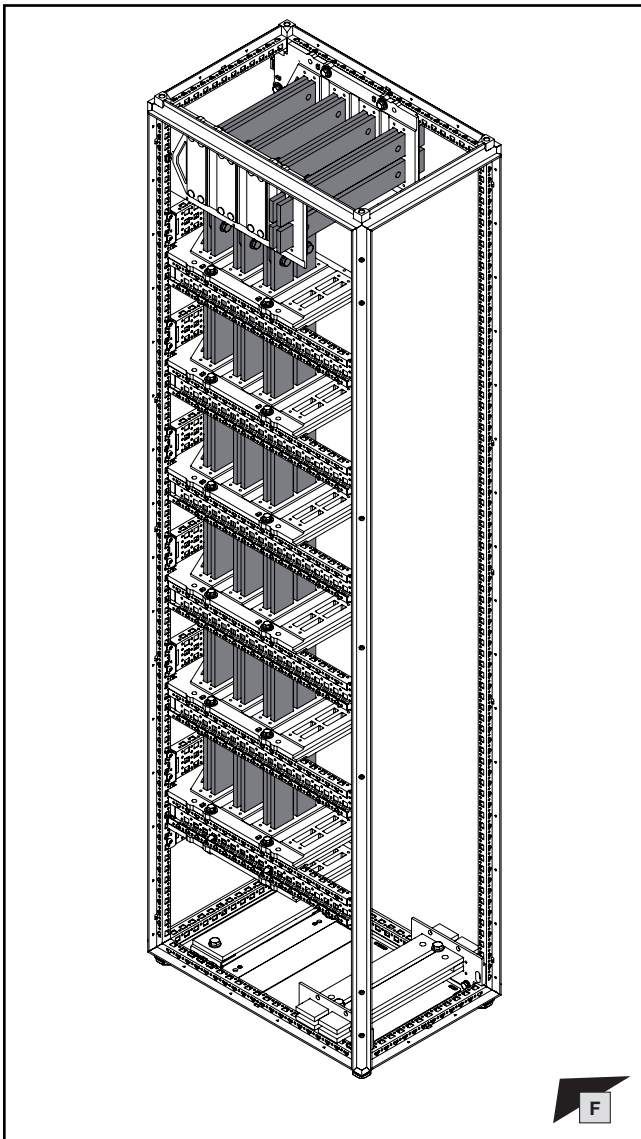

Sammelschiene Abmessung mm Busbar dimension mm Dimensions de la barre mm	Anreihung Baying Juxtaposition	(A) Best.-Nr. Model No. Référence
30 x 10	✓	9686.000
50 x 10	✓	9686.030

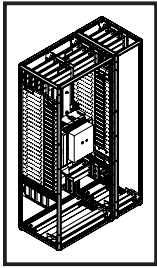

**5. Montage 3-poliges HSS**  
**5. Fitting the 3-pole MBS**  
**5. Montage des JBP tripolaires**

- 5.3 Übersicht 3-poliges HSS
- 5.3 Overview of 3-pole main busbar system
- 5.3 Vue d'ensemble des jeux de barres principaux tripolaires

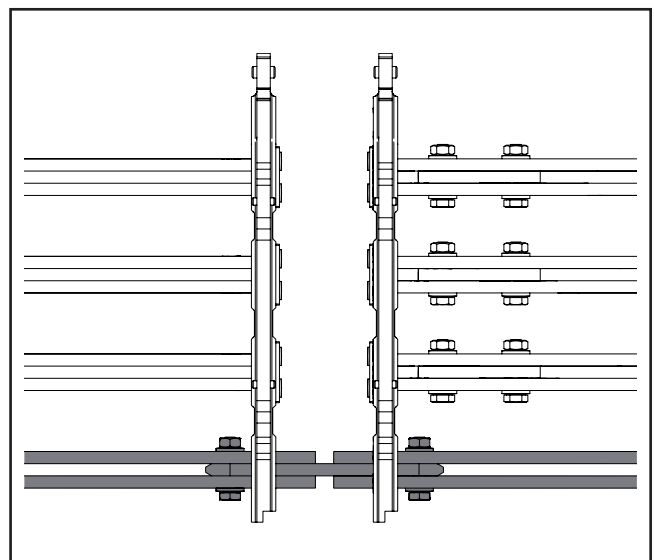
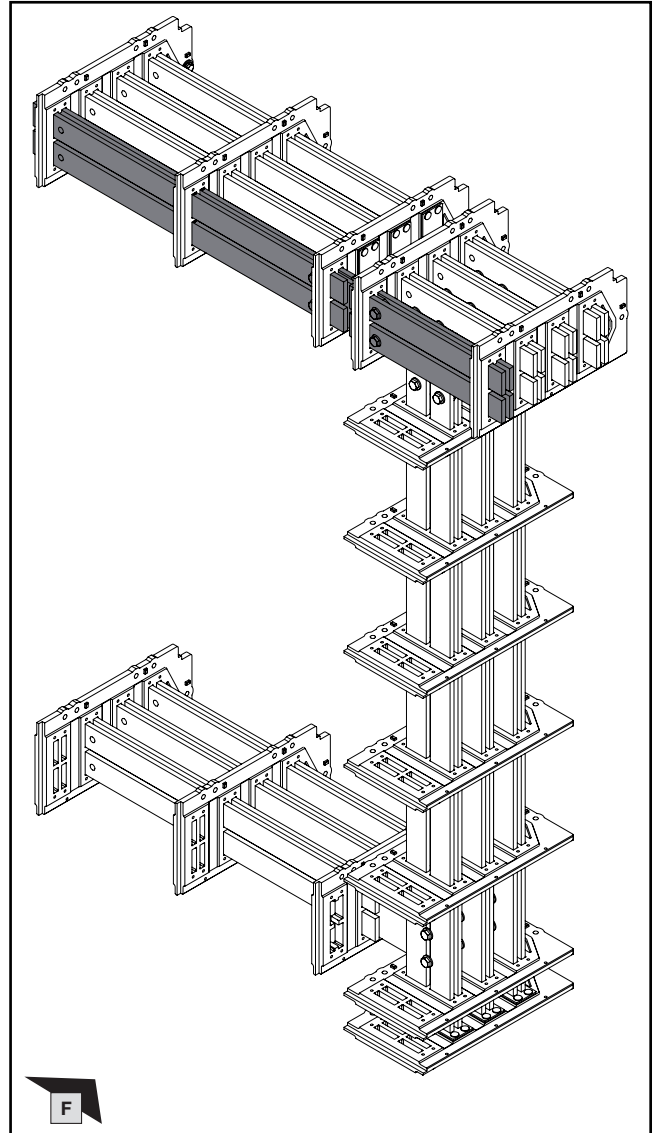
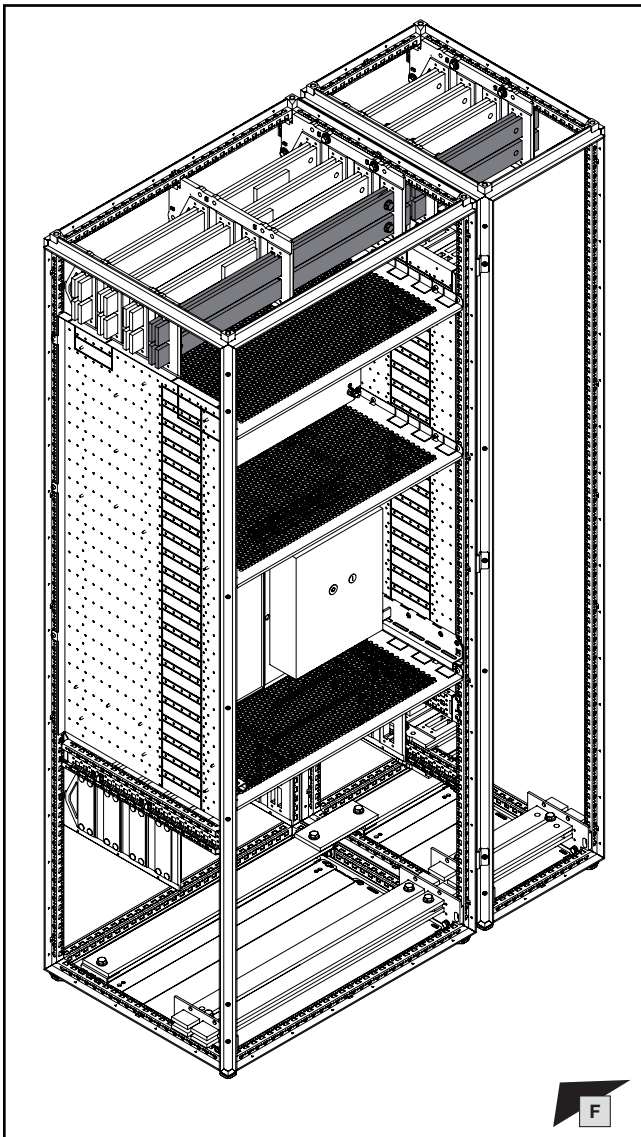

**Hinweis / Note / Remarque**  
 Die Endabdeckungen 9686.080 an den Sammelschienenhaltern werden für freie Einschübe (fehlender N-Leiter) nicht benötigt.  
 The end covers 9686.080 on the busbar supports are not required for free slots (missing N conductor).  
 Les couvercles d'extrémité 9686.080 des supports de jeux de barres ne sont pas nécessaires pour les coffrets rackables libres (sans Neutre).

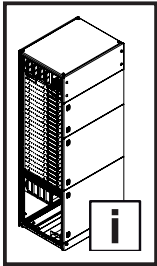

6. Stabilisierung verschiedener Laschenhöhen des offenen Leistungsschalters  
 6. Stabilising different circuit-breaker connector heights  
 6. Stabilisation de différents raccordements de disjoncteurs de puissance

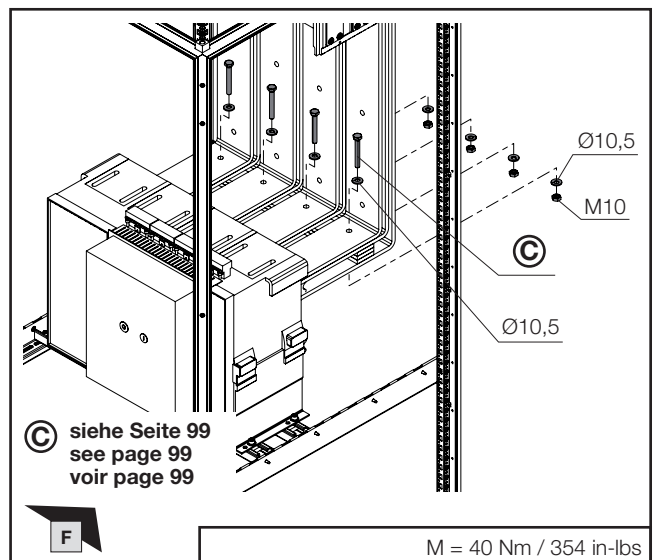
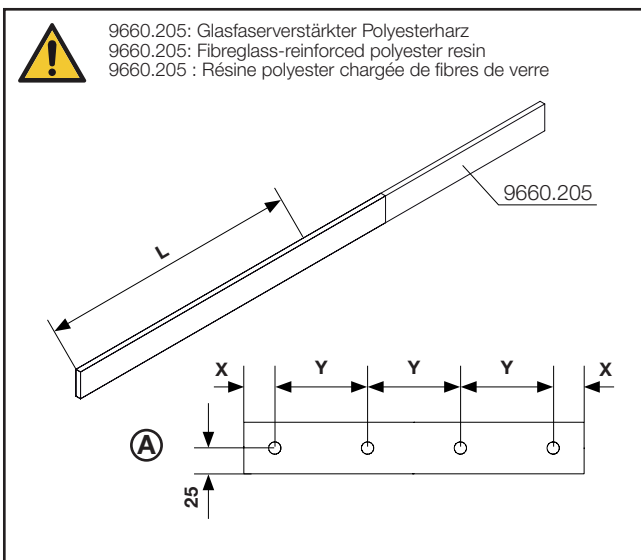
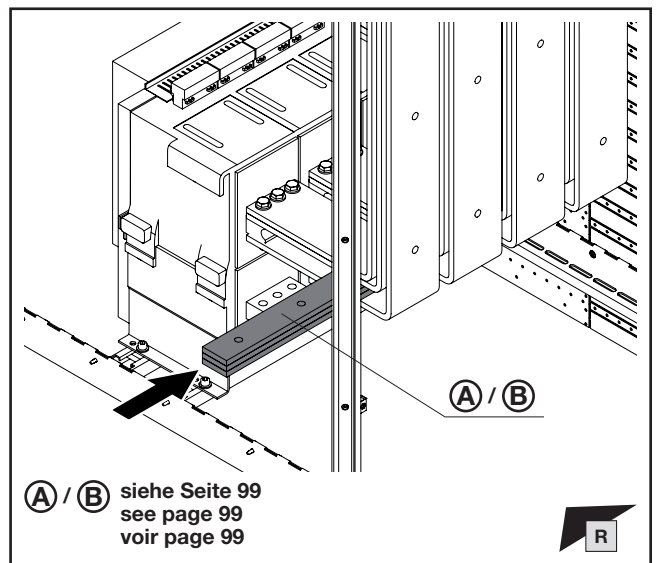
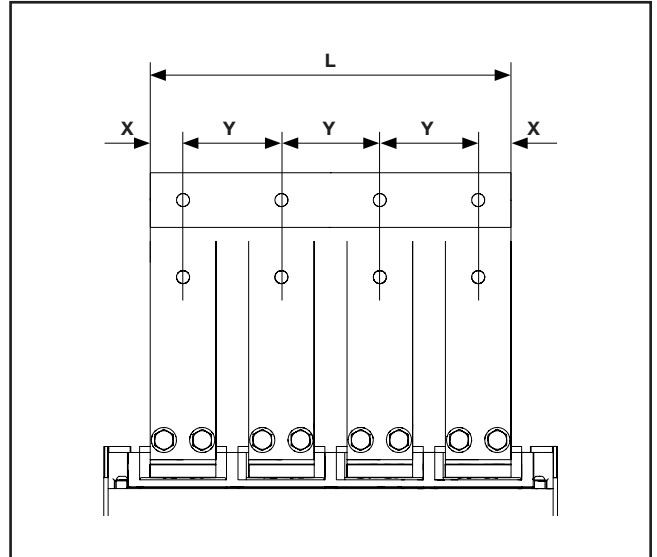
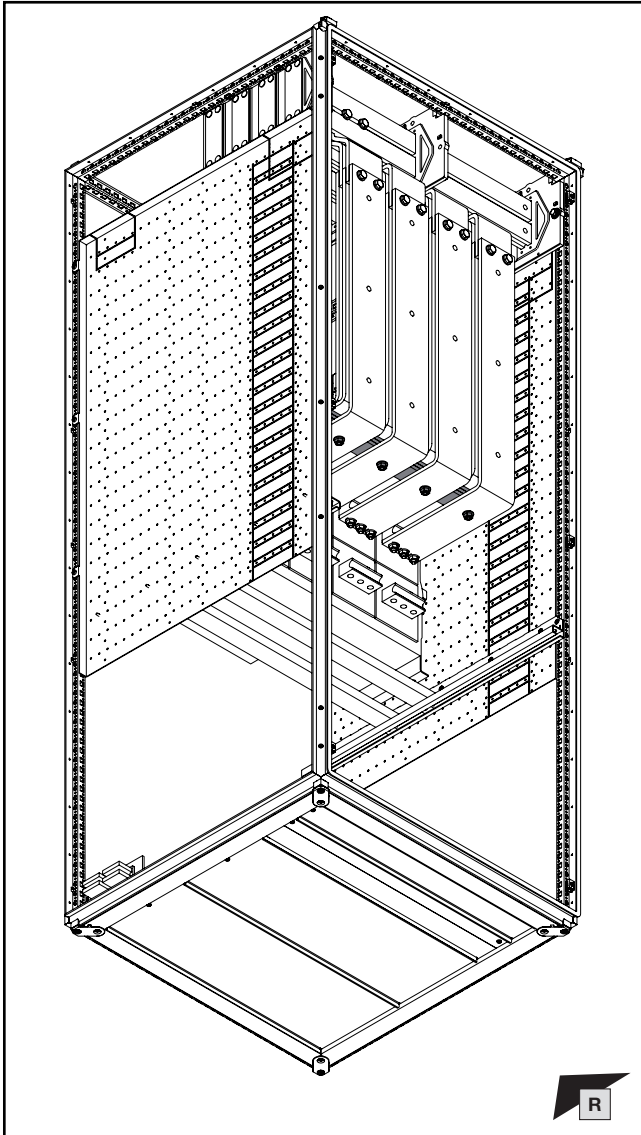

M = 40 Nm / 354 in-lbs

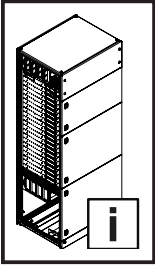

- 6. Stabilisierung verschiedener Laschenhöhen des offenen Leistungsschalters
- 6. Stabilising different circuit-breaker connector heights
- 6. Stabilisation de différents raccordements de disjoncteurs de puissance

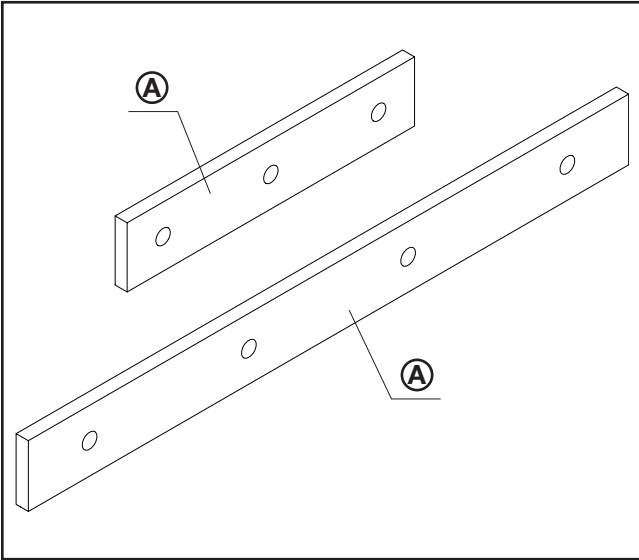

Sammelschienenverbindungen  
Busbar connections  
Jonctions de jeux de barres

©  
L = D + 15

Ausführung Screw design Type de vis	Schraube mm mm mm	Best.-Nr. Model No. Référence
M10 x 35		9686.830
M10 x 45		9686.845
M10 x 55		9686.865
M10 x 65		9686.855

Montageanleitung VX25 Ri4Power – Schalt- und Energieverteilanlagen-System

Assembly instructions VX25 Ri4Power – Switchgear and power distribution system

Notice de montage VX25 Ri4Power – Distribution de courant

DE/EN/FR

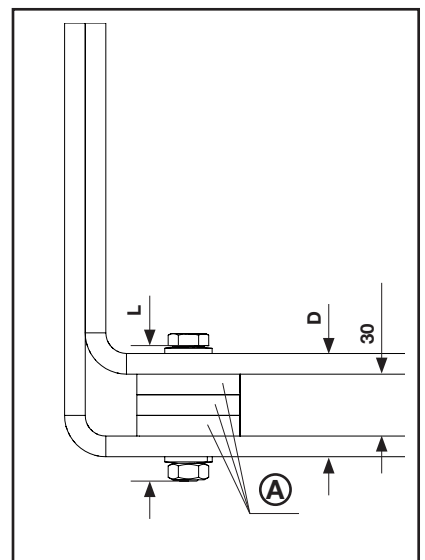
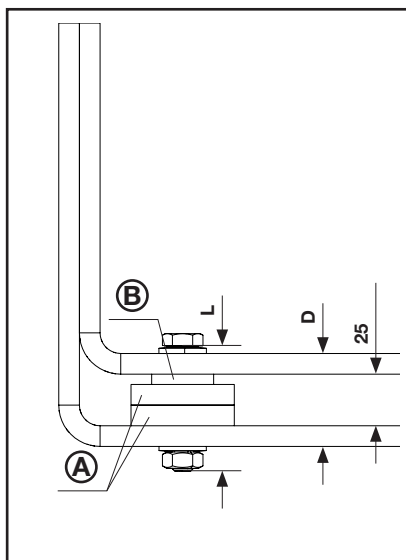
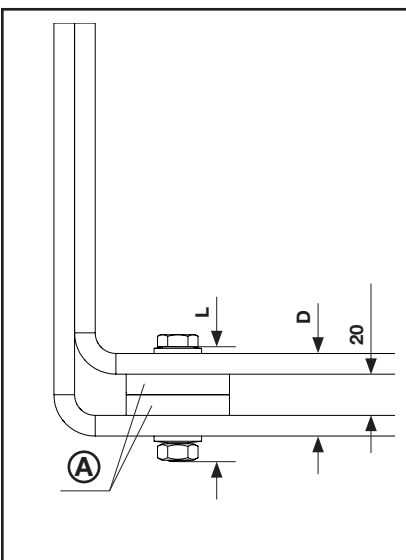
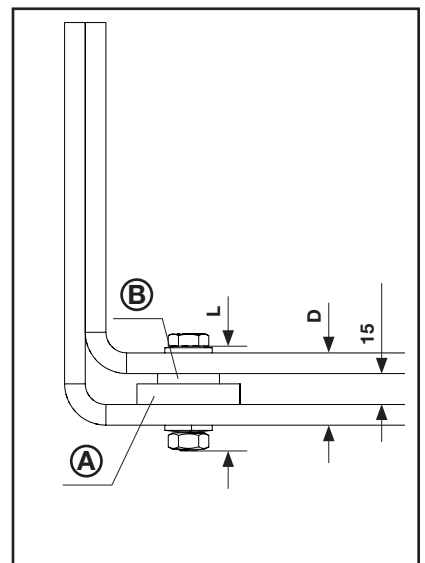
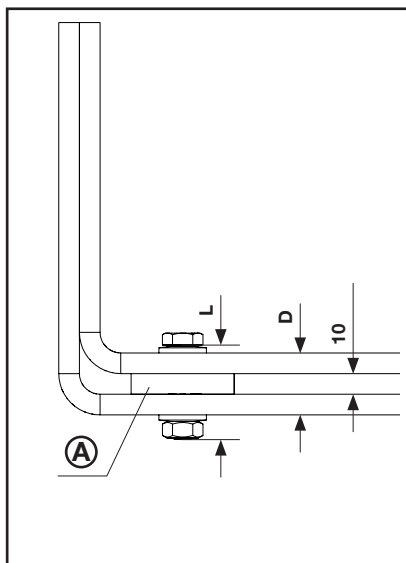
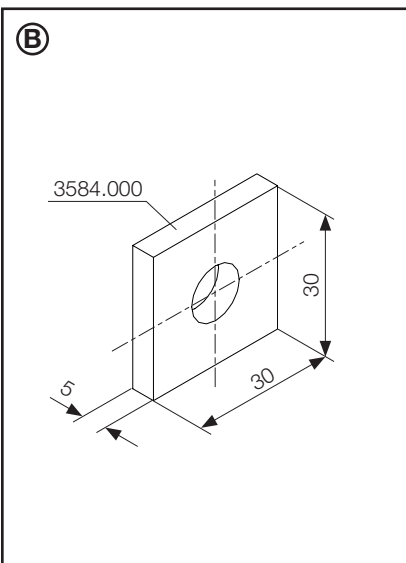

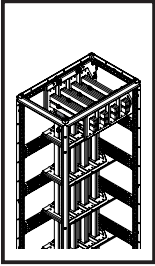

SW16/  
SW17

DE EN FR



## 7. Hauptsammelschienensystem 4 x 30 x 10

## 7. Main busbar system 4 x 30 x 10

## 7. Jeux de barres principaux 4 x 30 x 10

- 7.1 Montage Hochführungsfeld – Anbindung vertikales Verteilsammelschienensystem
- 7.1 Fitting the riser section – Connecting the vertical multi-terminal busbar system
- 7.1 Montage de zone d'installation verticale – connexion aux jeux de barres de distribution verticaux

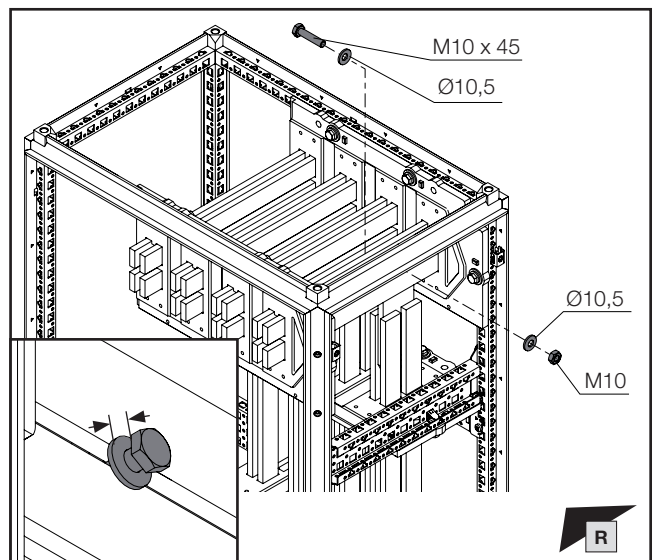
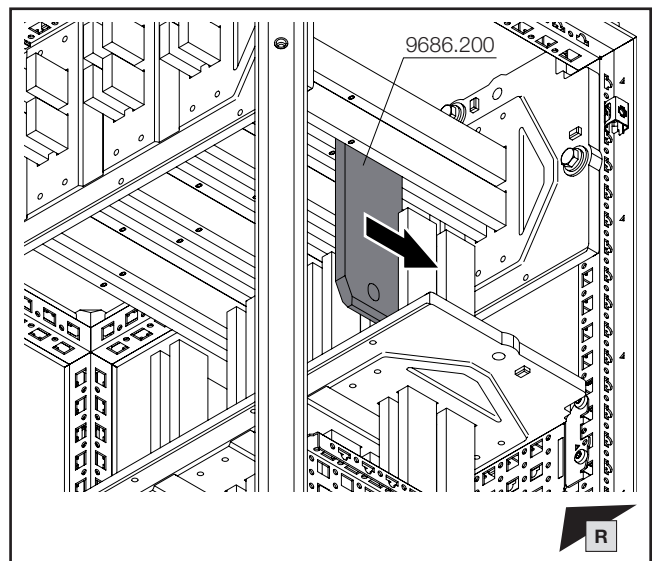
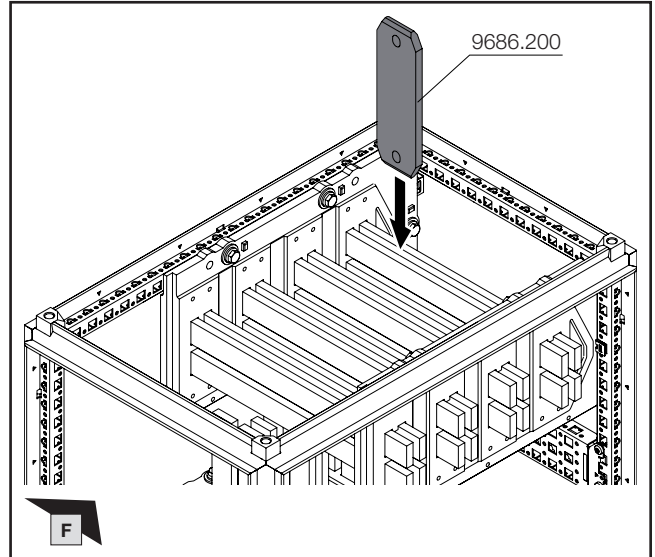
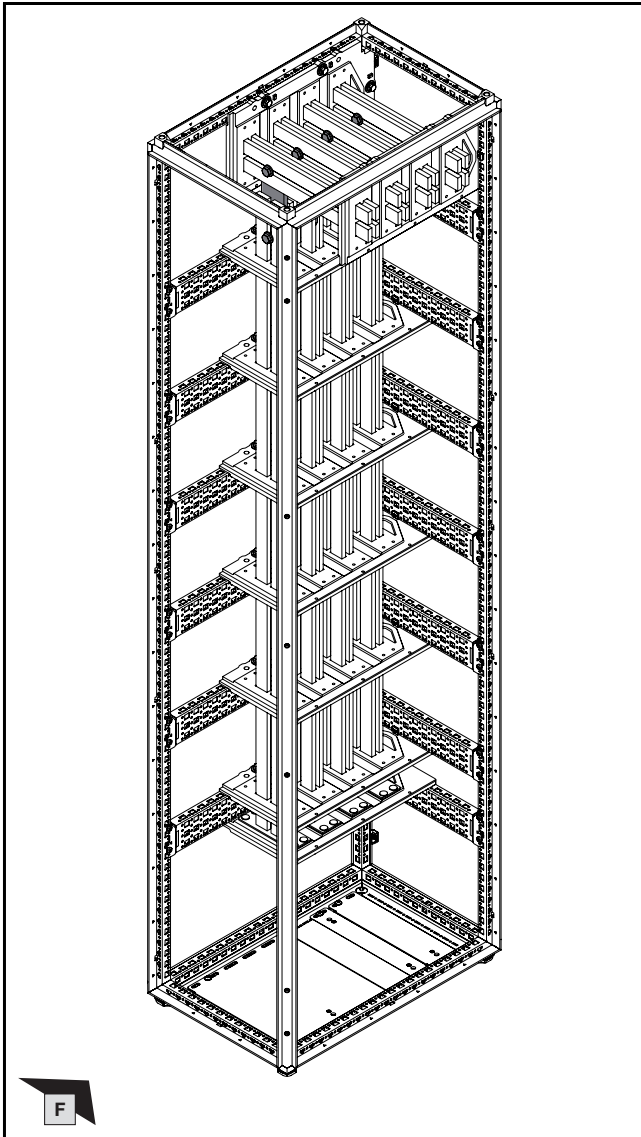

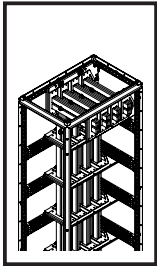

SW16/  
SW17



## 7. Hauptsammelschienensystem 4 x 30 x 10

### 7. Main busbar system 4 x 30 x 10

### 7. Jeux de barres principaux 4 x 30 x 10

- 7.1 Montage Hochführungsfeld – Anbindung vertikales Verteilsammelschienensystem
- 7.1 Fitting the riser section – Connecting the vertical multi-terminal busbar system
- 7.1 Montage de zone d'installation verticale – connexion aux jeux de barres de distribution verticaux

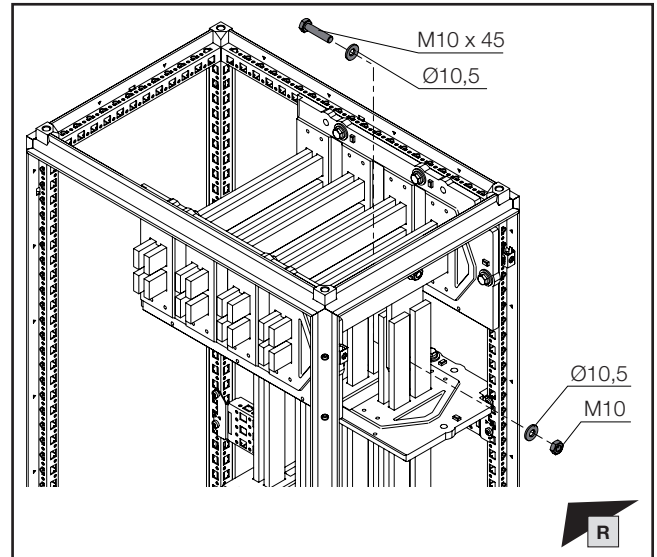
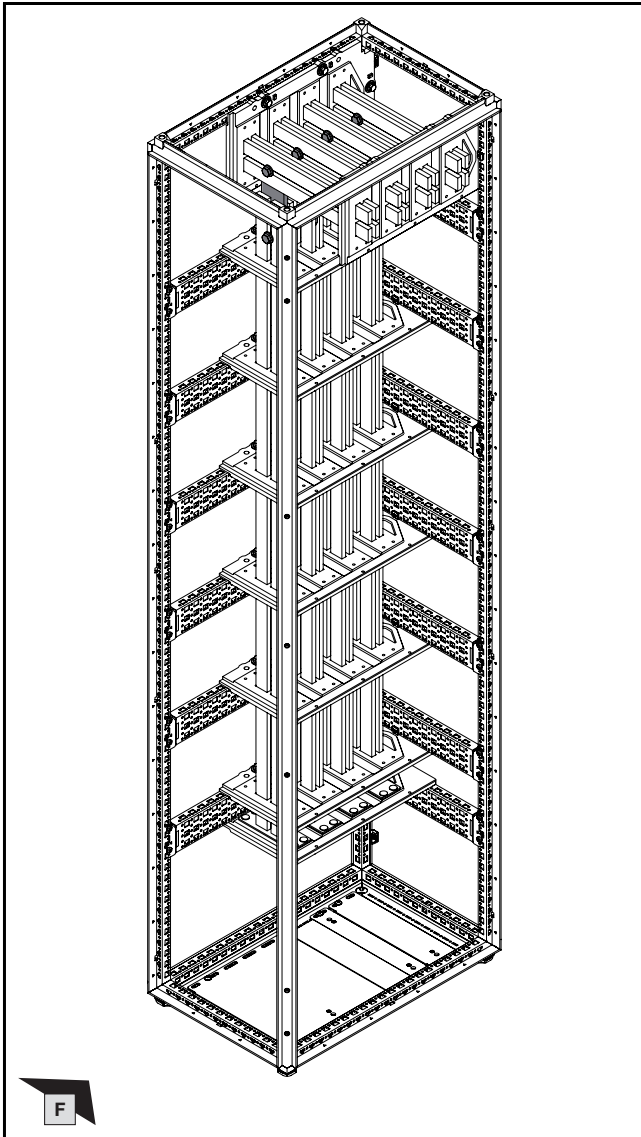

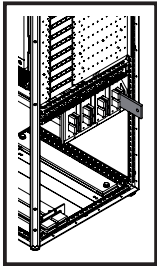

## 7. Hauptsammelschienensystem 4 x 30 x 10

### 7. Main busbar system 4 x 30 x 10

### 7. Jeux de barres principaux 4 x 30 x 10

- 7.2 Vorbereitung Sammelschienensystem – Einführen der Längsverbinder
- 7.2 Preparing the busbar system – Inserting the longitudinal connectors
- 7.2 Préparation des jeux de barres – introduction des éléments de jonction longitudinaux

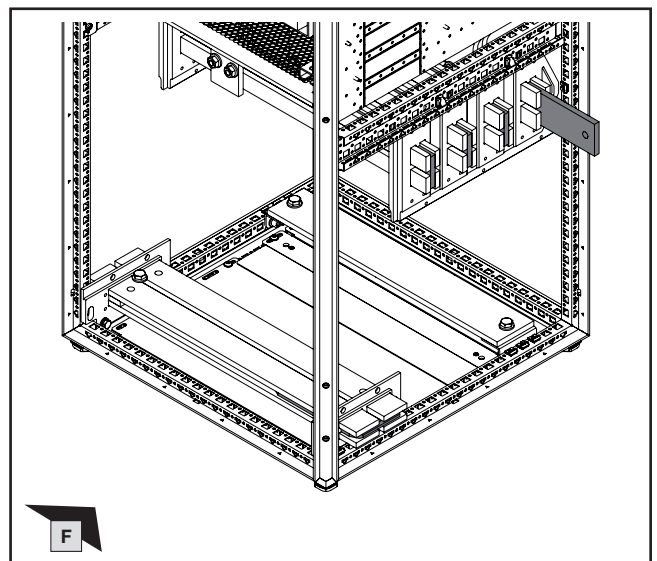
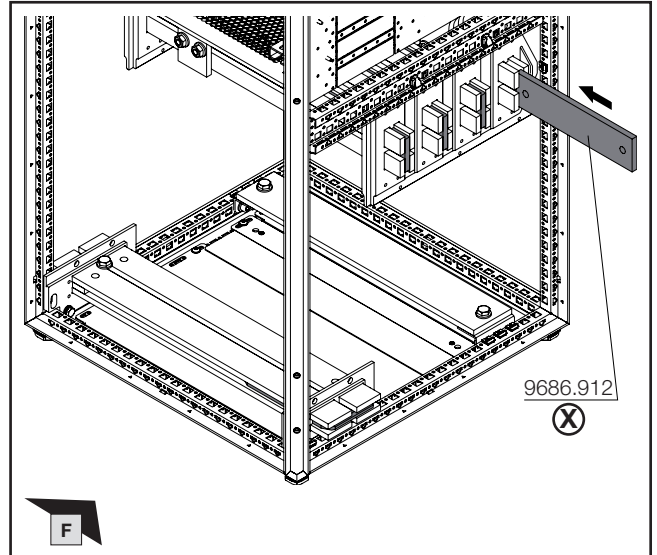
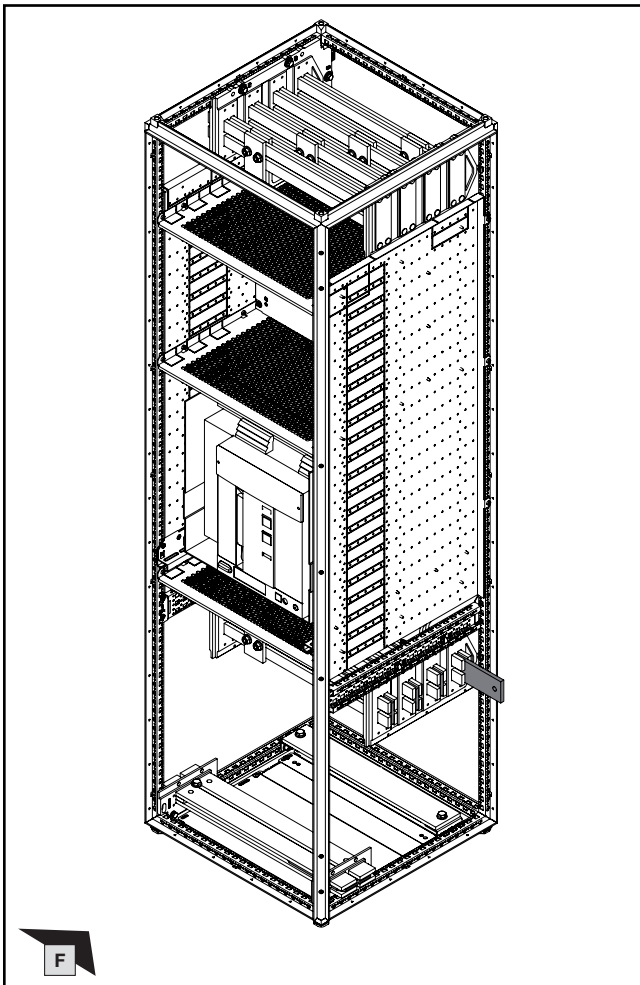

#### Hinweis / Note / Remarque (X)

Die Länge der Längsverbinder L1 bis L3 wird mit Hilfe der Online-Berechnungssoftware „RiPower“ im Niederspannungsschaltanlagen Konfigurator ermittelt.

The length of the longitudinal connectors L1 to L3 is determined using the online calculation software "RiPower" in the low-voltage switchgear configurator.

La longueur des éléments de jonction longitudinaux L1 à L3 est déterminée à l'aide du logiciel de calcul en ligne « VX25 Rittal Power Engineering » du configurateur de TGBT Ri4Power.



RiPower

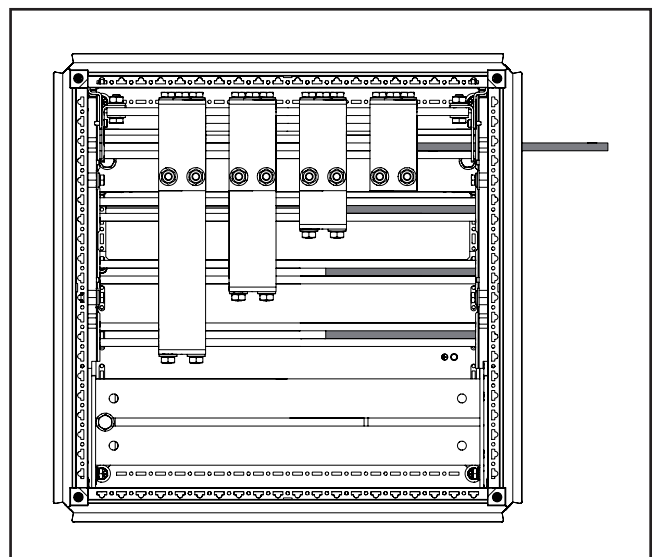

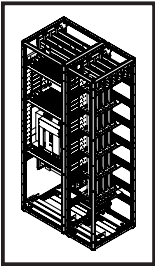

**7. Hauptsammelschienensystem 4 x 30 x 10**  
**7. Main busbar system 4 x 30 x 10**  
**7. Jeux de barres principaux 4 x 30 x 10**

- 7.3 Zusammenfügen der Schaltanlagenfelder – Montage der Anreihverbinder
- 7.3 Joining the switchgear sections together – Fitting the baying connectors
- 7.3 Assemblage des différentes cellules de distribution électrique – montage des attaches de juxtaposition

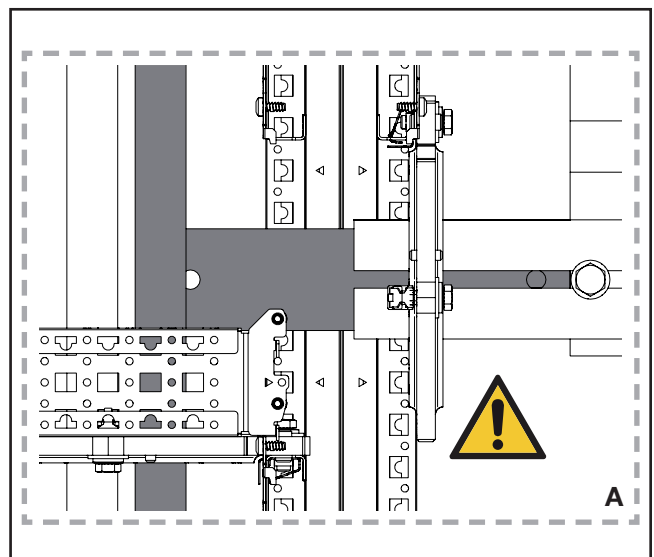
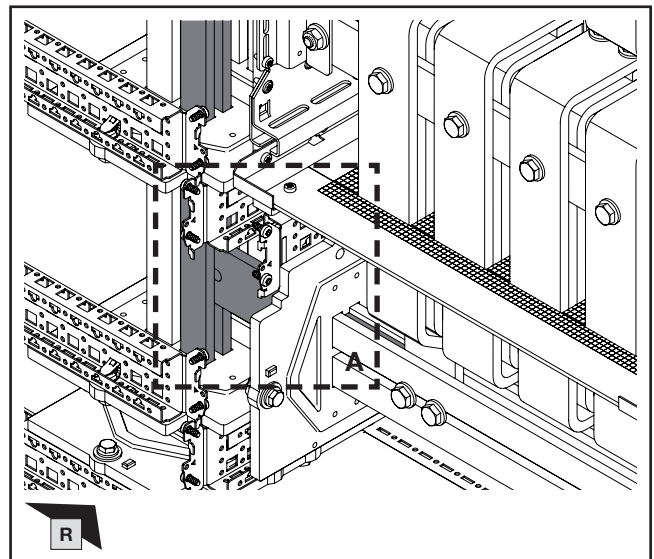
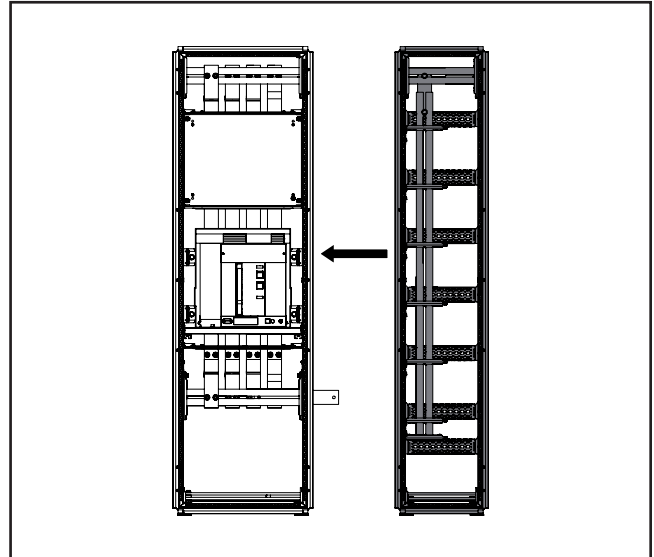
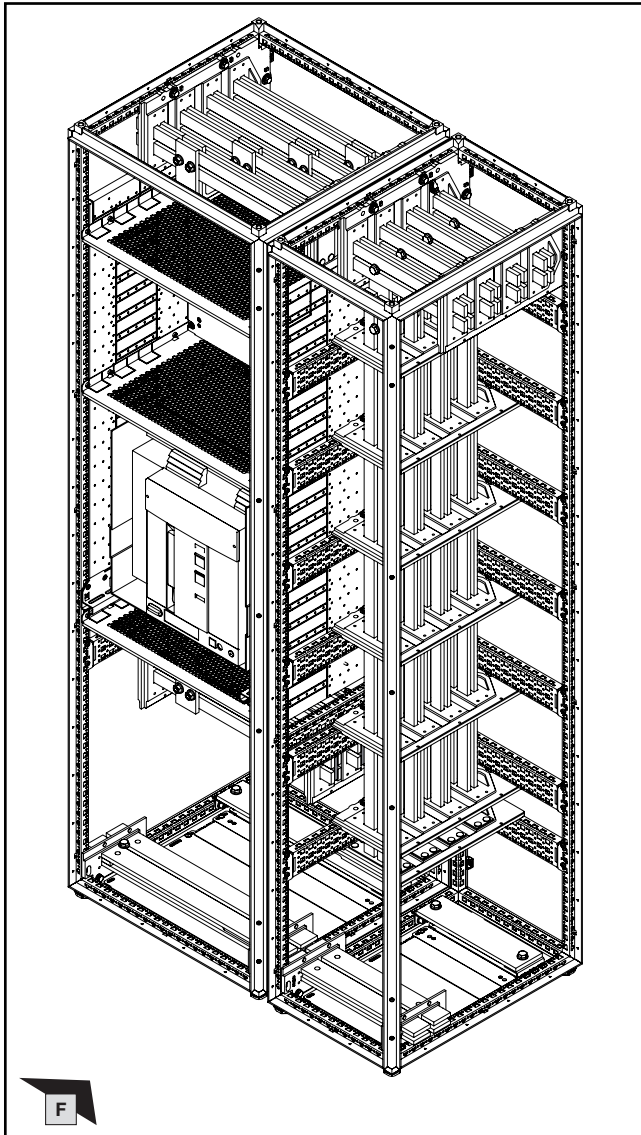

**Hinweis / Note / Remarque**

Beim Zusammenfügen der beiden Schaltanlagenfelder ggf. Schrauben lösen, um das Einschieben des Längsverbinders zu erleichtern. Ansonsten können die HSS-Systeme beschädigt werden.

When joining the two switchgear sections together, loosen the screws if necessary to make insertion of the longitudinal connector easier. Otherwise the MBS systems may be damaged.

Desserrer si nécessaire les vis pour faciliter l'insertion des éléments de jonction longitudinaux lors de l'assemblage des deux zones de distribution électrique. Les jeux de barres principaux pourraient sinon être endommagés.

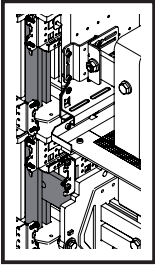

SW16/  
SW17 



## 7. Hauptsammelschienensystem 4 x 30 x 10

### 7. Main busbar system 4 x 30 x 10

### 7. Jeux de barres principaux 4 x 30 x 10

- 7.4 Verschrauben der Längsverbinder
- 7.4 Screw-fastening the longitudinal connectors
- 7.4 Vissage des éléments de jonction longitudinaux

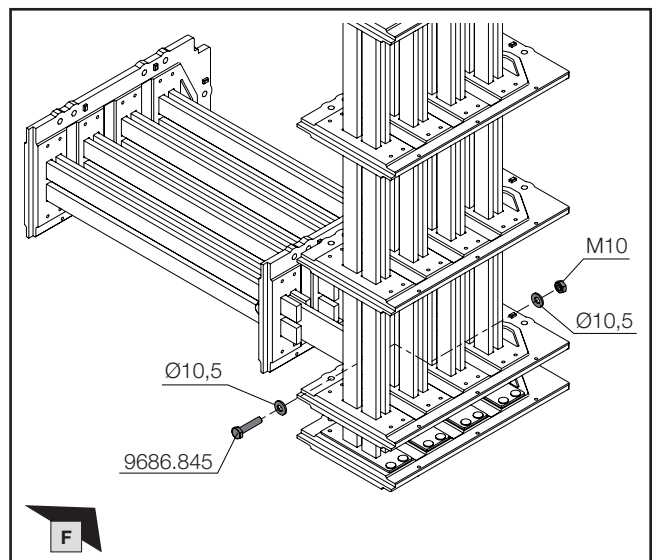
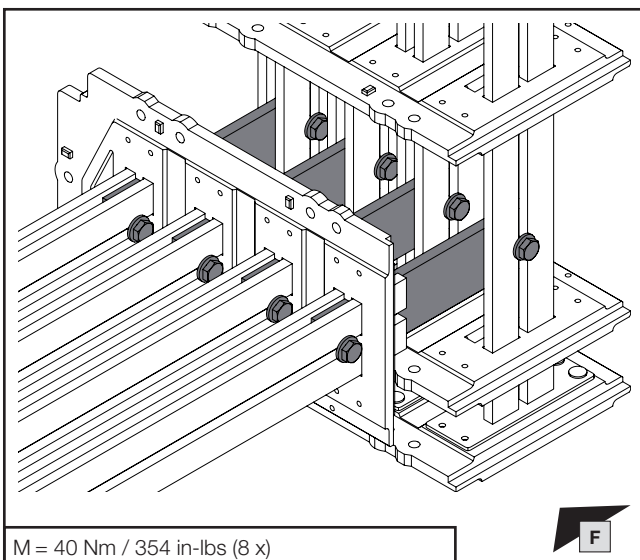
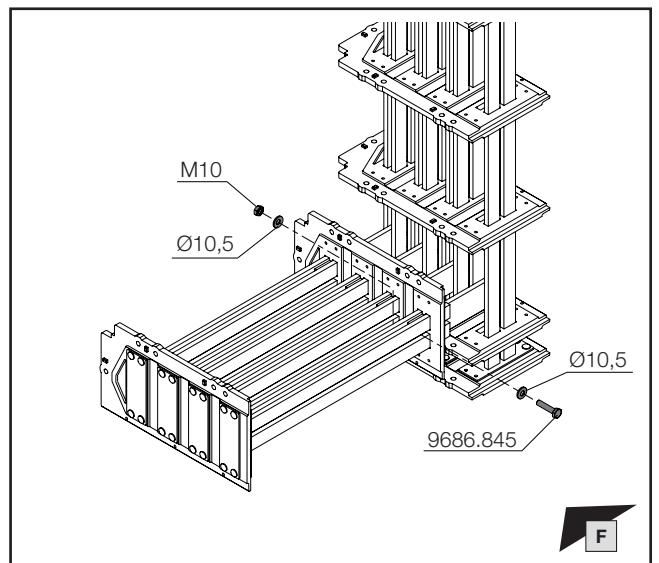
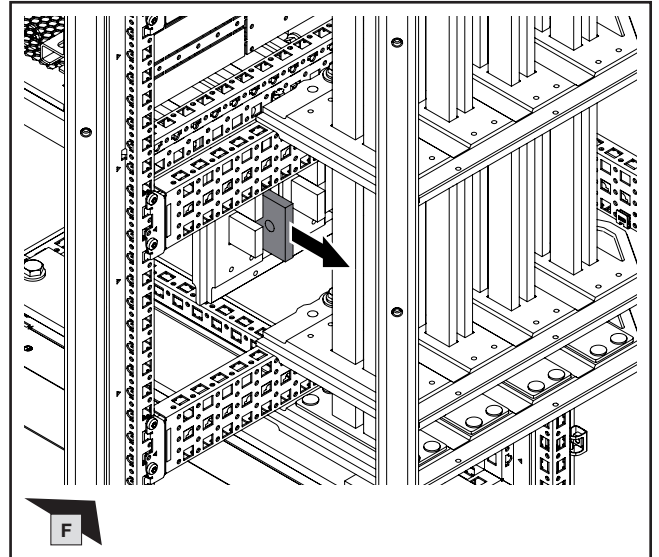
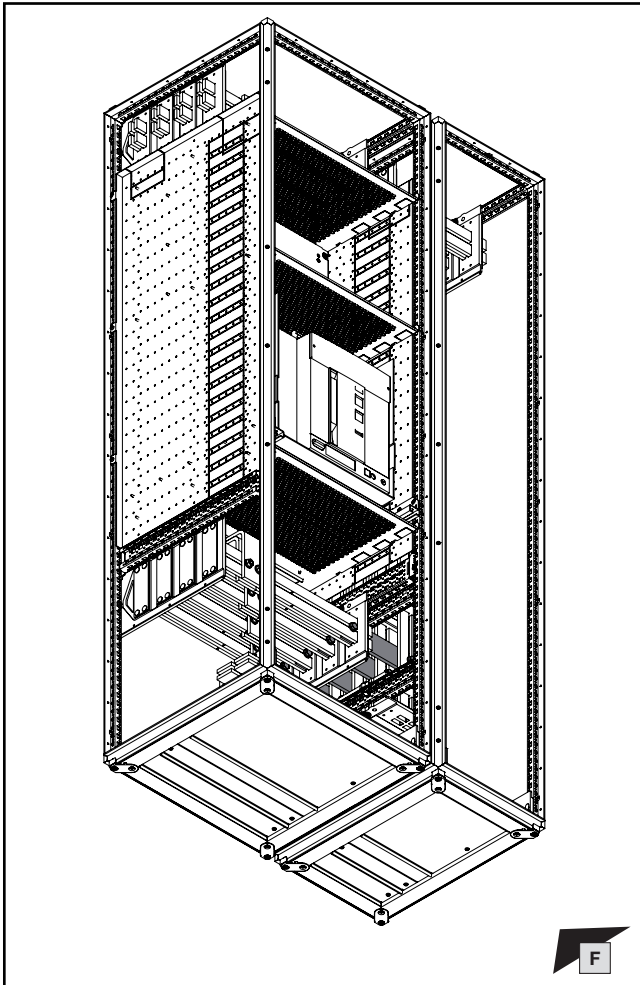

M = 40 Nm / 354 in-lbs (8 x)

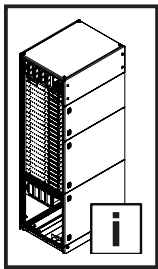

**Artikelverzeichnis**  
**List of model numbers**  
**Liste des références**

Best.-Nr. Model No. Référence	Kapitel Chapter Chapitre
3584.000	6
3586.005	1.9 1.10 2.7
4165.500	1.9 1.10 2.6 2.7
8617.110	2.3 2.6
8617.130	1.10 2.3 2.6
8617.140	1.10 2.3 2.6
8617.502	3.3
8680.828	1.2
9660.205	1.12 1.13 6
9680.080	2.4 2.6
9680.406	2.2
9680.408	2.2
9680.426	2.2
9680.428	2.2
9680.606	1.2
9680.608	1.2
9680.626	1.2
9680.628	1.2
9680.806	1.2
9680.808	1.2
9680.826	1.2
9681.646	4.1
9681.648	4.1
9681.666	4.1
9681.668	4.1
9681.686	4.1
9681.688	4.1
9682.104	4.1
9682.106	4.1
9682.108	4.1
9682.124	4.1
9682.126	4.1
9682.128	4.1
9682.140	4.1
9682.142	4.1
9682.143	4.1
9682.144	4.1
9682.146	4.1

Best.-Nr. Model No. Référence	Kapitel Chapter Chapitre
9682.148	4.1
9682.156	4.1
9682.158	4.1
9682.160	4.1
9682.161	4.1
9682.162	4.1
9682.163	4.1
9682.164	4.1
9682.166	4.1
9682.167	4.1
9682.168	4.1
9682.169	4.1
9682.176	4.1
9682.178	4.1
9682.180	4.1
9682.181	4.1
9682.182	4.1
9682.183	4.1
9682.184	4.1
9682.186	4.1
9682.187	4.1
9682.188	4.1
9682.196	4.1
9682.198	4.1
9682.320	4.1
9682.322	4.1
9682.324	4.1
9682.326	4.1
9682.328	4.1
9682.330	4.1
9682.332	4.1
9682.334	4.1
9682.336	4.1
9682.338	4.1
9683.016	1.4 1.5 1.6
9683.018	1.4 1.5 1.6
9683.036	1.4 1.5 1.6
9683.038	1.4 1.5 1.6
9683.040	2.7
9683.306	1.11
9683.310	1.11

Best.-Nr. Model No. Référence	Kapitel Chapter Chapitre
9683.312	1.11
9683.326	1.11
9683.328	1.11
9683.406	1.15
9683.408	1.15
9683.426	1.15
9683.428	1.15
9683.466	1.15
9683.468	1.15
9683.486	1.15
9683.488	1.15
9683.500	1.15
9683.506	1.15
9683.508	1.15
9683.604	1.16
9683.606	1.16
9683.608	1.11 1.16
9683.624	1.16
9683.626	1.16
9683.628	1.16
9683.660	1.16
9683.661	1.16
9683.662	1.16
9683.663	1.16
9683.664	1.16
9683.666	1.16
9683.668	1.16
9683.680	1.16
9683.681	1.16
9683.682	1.16
9683.683	1.16
9683.684	1.16
9683.686	1.16
9683.688	1.16
9684.004	1.9 1.10 2.7
9684.006	1.8 1.9 1.10 2.7 2.10
9684.008	1.8 1.9 1.10 2.7 2.10
9684.010	1.8 1.9 1.10 2.7

Best.-Nr. Model No. Référence	Kapitel Chapter Chapitre
9684.010	2.10
9684.012	1.8 1.9 1.10 2.7 2.10
9686.000	1.9 1.10 2.7 5.2
9686.010	1.9 1.10 2.4 2.6 2.7 5.2
9686.030	1.9 1.10 2.7 5.2
9686.040	1.9 1.10 2.4 2.6 5.2
9686.080	1.9 1.10 2.7
9686.200	7.1
9686.250	2.8 3.2
9686.300	1.8 2.10
9686.350	1.7 2.9
9686.495	1.12 1.13
9686.520	1.7 2.9
9686.522	1.7 2.9
9686.526	1.7 2.9
9686.528	1.7 2.9
9686.529	3.4
9686.530	1.7 2.9
9686.532	1.7 2.9
9686.536	1.7 2.9
9686.538	1.7 2.9
9686.539	3.4
9686.540	1.7 2.9
9686.542	1.7 2.9
9686.546	1.7 2.9

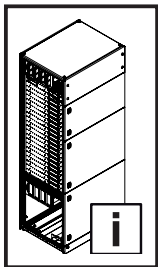

**Artikelverzeichnis**  
**List of model numbers**  
**Liste des références**

Best.-Nr. Model No. Référence	Kapitel Chapter Chapitre
9686.548	1.7 2.9
9686.549	3.4
9686.580	1.7 2.9
9686.582	1.7 2.9
9686.586	1.7 2.9
9686.588	1.7 2.9
9686.589	3.4
9686.820	1.8 2.10 3.2 3.4
9686.830	1.12 1.13 6
9686.845	1.8 1.12 1.13 2.10 3.4 6 7.4
9686.855	1.12 1.13 6
9686.865	1.12 1.13 6
9686.885	1.12 1.13
9686.912	1.12 1.13 3.2 5.2

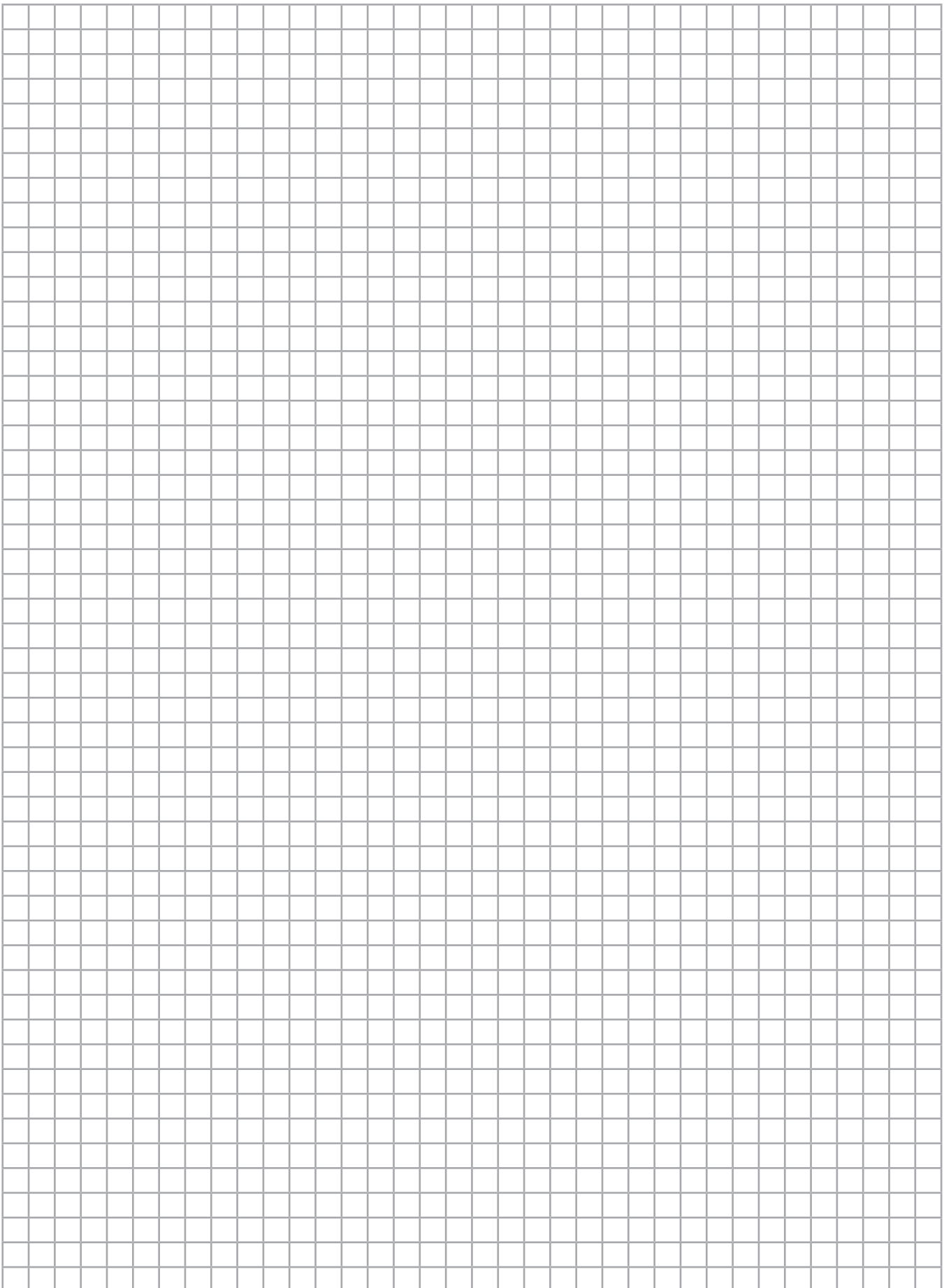

# Rittal – The System.

Faster – better – everywhere.

- Enclosures
- Power Distribution
- Climate Control
- IT Infrastructure
- Software & Services

You can find the contact details of all Rittal companies throughout the world here.



[www.rittal.com/contact](http://www.rittal.com/contact)

RITTAL GmbH & Co. KG  
Auf dem Stuetzelberg · 35745 Herborn · Germany  
Phone +49 2772 505-0  
E-mail: [info@rittal.de](mailto:info@rittal.de) · [www.rittal.com](http://www.rittal.com)

08.2025/D-0000-00002033-11

ENCLOSURES

POWER DISTRIBUTION

CLIMATE CONTROL

IT INFRASTRUCTURE

SOFTWARE & SERVICES

FRIEDHELM LOH GROUP

