

Rittal – The System.

Faster – better – everywhere.

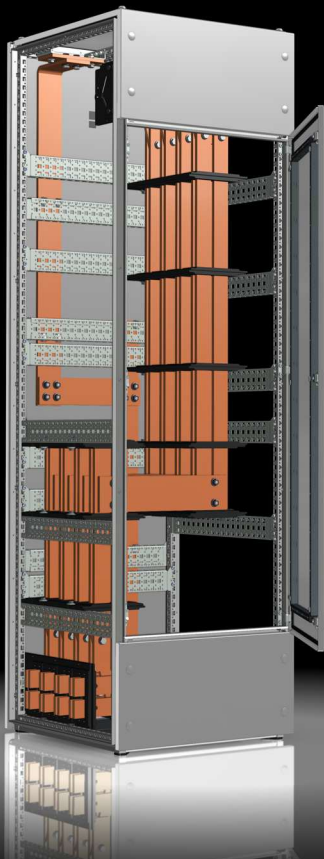

Hochführungsfeld Dach-/Bodenbereich (Kapitel A.18)

Riser section, roof/base area (chapter A.18)

Zone de montage vertical toit / base (chapitre A.18)

Anhang VX25 Ri4Power – Montageanleitung

Appendix VX25 Ri4Power – Assembly instructions

Annexe VX25 Ri4Power – Notice de montage

ENCLOSURES

POWER DISTRIBUTION

CLIMATE CONTROL

IT INFRASTRUCTURE

SOFTWARE & SERVICES

FRIEDHELM LOH GROUP



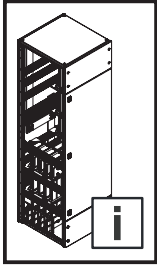

Inhaltsverzeichnis

Contents

Sommaire

DE

1. Montage Hochführungsfeld – Einbaulage Boden auf Dach	5
1.1 Umlenkungsfeld 600 mm oder 800 mm tief (4 x 50 x 10)	5
1.2 Vorbereitung Modulschrank	6
1.3 Montage des unteren Hauptschienen-systems	7
1.4 Montage untere System-Chassis	11
1.5 Montage untere Sammelschienenhalter vertikal	14
1.6 Einbringung untere vertikale Verteil-sammelschienen	17
1.7 Anbindung unteres vertikales Verteil-sammelschienensystem	18
1.8 Montage mittlere System-Chassis	20
1.9 Montage mittlere Sammelschienenhalter vertikal	22
1.10 Einbringung obere vertikale Verteil-sammelschienen	25
1.11 Montage obere System-Chassis und Sammelschienenhalter	26
1.12 Montage des oberen Hauptschienen-systems	30
1.13 Anbindung oberes vertikales Verteil-sammelschienensystem	34
1.14 Verbindung der vertikalen Verteilsammel-schienensysteme	36
1.15 Montage System-Chassis und Sammel-schienenhalter	37
1.16 Anziehen der Schrauben	40
1.17 Montage des unteren PE-/PEN-Sammel-schienensystems	41
1.18 Montage des oberen PE-/PEN-Sammel-schienensystems	47
1.19 Verbindung des oberen und unteren PE-/PEN-Sammelschienensystems	52
1.20 Montage Flachteile und Dachblech	54
2. Besonderheiten	55
2.1 Sammelschienensystem 2 x 50 x 10	55
2.2 Sammelschienensystem 4 x 30 x 10	58
2.3 Sammelschienensystem 2 x 30 x 10	61
2.4 Hochführungsfeld 800 mm tief mit 2 x 4 x 50 x 10 Verteilsammelschienen	64
2.5 Hochführungsfeld 2200 mm hoch	65
Artikelverzeichnis	68

EN

1. Fitting the riser section – Mounting position: Base section to roof	5
1.1 Riser section 600 mm or 800 mm deep (4 x 50 x 10)	5
1.2 Preparing the modular enclosure	6
1.3 Fitting the lower main busbar system	7
1.4 Fitting the lower punched sections with mounting flanges	11
1.5 Fitting the lower busbar supports, vertical	14
1.6 Incorporating the lower vertical distribu-tion busbars	17
1.7 Connecting the lower vertical multi-termi-nal busbar system	18
1.8 Fitting the middle punched section with mounting flange	20
1.9 Fitting the middle busbar holder, vertical	22
1.10 Incorporating the upper vertical distribu-tion busbars	25
1.11 Fitting the upper punched sections with mounting flanges and busbar supports	26
1.12 Fitting the upper main busbar system	30
1.13 Connecting the upper vertical multi-termi-nal busbar system	34
1.14 Connecting the vertical multi-terminal busbar systems	36
1.15 Fitting the punched section with mounting flange and busbar support	37
1.16 Tightening the screws	40
1.17 Fitting the lower PE/PEN busbar system	41
1.18 Fitting the upper PE/PEN busbar system	47
1.19 Connecting the upper and lower PE/PEN busbar system	52
1.20 Fitting the panels and roof plate	54
2. Particular features	55
2.1 Busbar system 2 x 50 x 10	55
2.2 Busbar system 4 x 30 x 10	58
2.3 Busbar system 2 x 30 x 10	61
2.4 Riser section 800 mm deep with 2 x 4 x 50 x 10 distribution busbars	64
2.5 Riser section 2200 mm high	65
List of model numbers	68

FR

1. Zone de montage vertical – position base vers toit	5
1.1 Zone de montage vertical 600 mm ou 800 mm de profondeur (4 x 50 x 10)	5
1.2 Préparation de l'armoire modulaire	6
1.3 Montage des jeux de barres principaux inférieurs	7
1.4 Montage sous rails de montage	11
1.5 Montage des supports de jeux de barres verticaux inférieurs	14
1.6 Introduction des jeux de barres de distribu-tion verticaux inférieurs	17
1.7 Connexion aux jeux de barres de distribu-tion verticaux inférieurs	18
1.8 Montage du rail de montage central	20
1.9 Montage des supports centraux de jeux de barres verticaux	22
1.10 Introduction des jeux de barres de distribu-tion verticaux supérieurs	25
1.11 Montage des rails de montage supérieurs et des supports de jeux de barres	26
1.12 Montage des jeux de barres principaux supérieurs	30
1.13 Connexion des jeux de barres de distribu-tion verticaux supérieurs	34
1.14 Raccordement des jeux de barres de distribu-tion verticaux	36
1.15 Montage du rail de montage et des sup-ports de jeux de barres	37
1.16 Serrage des vis	40
1.17 Montage des jeux de barres Terre / Terre-Neutre inférieurs	41
1.18 Montage des jeux de barres Terre / Terre-Neutre supérieurs	47
1.19 Raccordement des jeux de barres Terre / Terre-Neutre supérieurs et inférieurs	52
1.20 Montage des pièces plates et du toit	54
2. Caractéristiques particulières	55
2.1 Jeu de barres avec 2 barres de courant 50 x 10	55
2.2 Jeu de barres avec 4 barres de courant 30 x 10	58
2.3 Jeu de barres avec 2 barres de courant 30 x 10	61
2.4 Zone de montage vertical 800 mm de profondeur avec jeux de barres de distribu-tion 2 x 4 x 50 x 10	64
2.5 Zone de montage vertical 2200 mm de hauteur	65
Liste des références	68

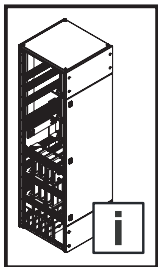

Inhaltsverzeichnis
Contents
Sommaire

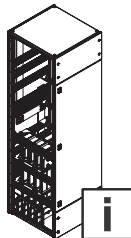

2-5,
68

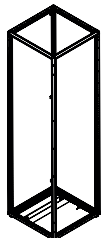

6

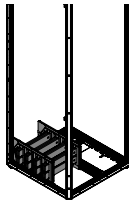

7-10

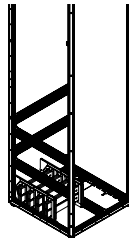

11-13

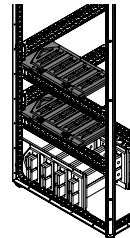

14-16

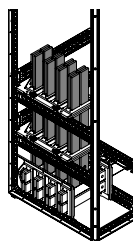

17

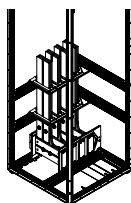

18-19

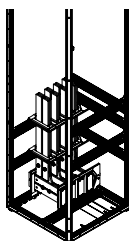

20-21

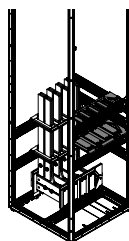

22-24

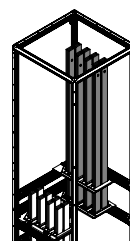

25

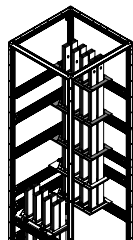

26-29

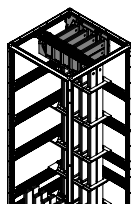

30-33

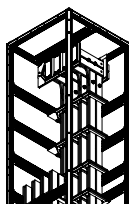

34-35

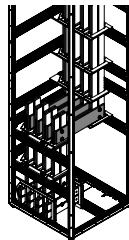

36

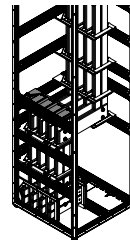

37-39

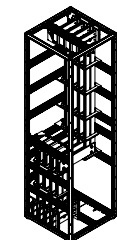

40

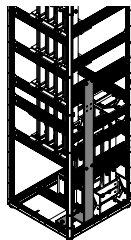

41-46

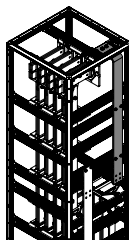

47-51

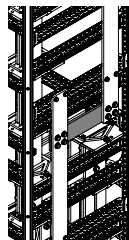

52-53

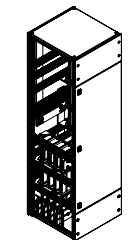

54

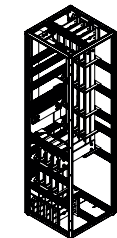

55-57

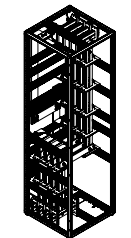

58-60

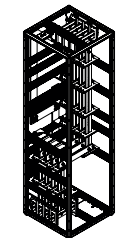

61-63

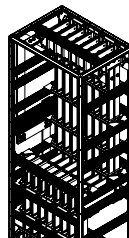

64

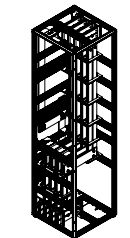

65-67

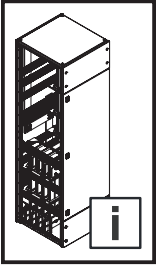

Mitgeltende Unterlagen Other applicable documents Autres documents applicables

DE

Für die hier beschriebenen Sammelschienenkomponenten steht diese Montageanleitung als Download unter www.rittal.de zur Verfügung. Für Schäden, die durch Nichtbeachtung dieser Anleitung entstehen, übernehmen wir keine Haftung. Zusätzlich gelten auch die Anleitungen des verwendeten Zubehörs sowie die VX25 Ri4Power Montageanleitung.

Bitte beachten Sie die Sicherheits- und Warnhinweise in der Montageanleitung „VX25 Ri4Power – Schalt- und Energieverteilanlagen-System“.

Montageanleitung VX25 Ri4Power – Schalt- und Energieverteilanlagen-System

Assembly instructions VX25 Ri4Power – Switchgear and power distribution system

Notice de montage VX25 Ri4Power – Distribution de courant

 DE/EN/FR

EN

These assembly instructions for the described busbar components can be downloaded from www.rittal.com. We cannot accept any liability for damage associated with failure to observe these instructions. The instructions for any accessories used, together with the VX25 Ri4Power assembly instructions, also apply.

Please observe the safety and warning notes in the "VX25 Ri4Power – Switchgear and power distribution system" assembly instructions.

FR

La présente notice de montage pour les composants du jeu de barres mentionnés ici peut être téléchargée sur le site internet www.rittal.fr. Nous déclinons toute responsabilité en cas de dommages imputables à la non-observation des instructions contenues dans ce document. Veuillez également respecter les instructions relatives aux accessoires utilisés ainsi que la notice de montage VX25 Ri4Power.

Veuillez respecter les consignes de sécurité et les avertissements figurant dans les instructions de montage « VX25 Ri4Power – Distribution de courant ».

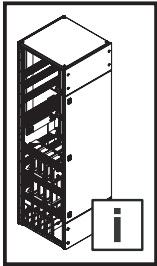

- 1. Montage Hochführungsfeld – Einbaulage Boden auf Dach
- 1. Fitting the riser section – Mounting position: Base section to roof
- 1. Zone de montage vertical – position base vers toit

- 1.1 Umlenkungsfeld 600 mm oder 800 mm tief (4 x 50 x 10)
- 1.1 Riser section 600 mm or 800 mm deep (4 x 50 x 10)
- 1.1 Zone de montage vertical 600 mm ou 800 mm de profondeur (4 x 50 x 10)

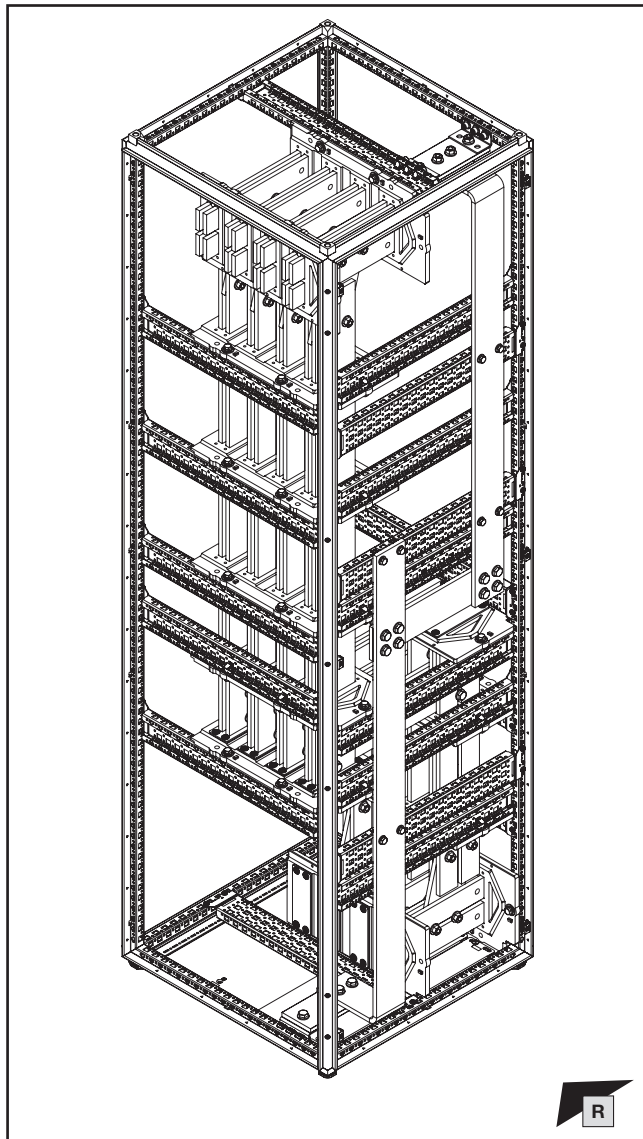
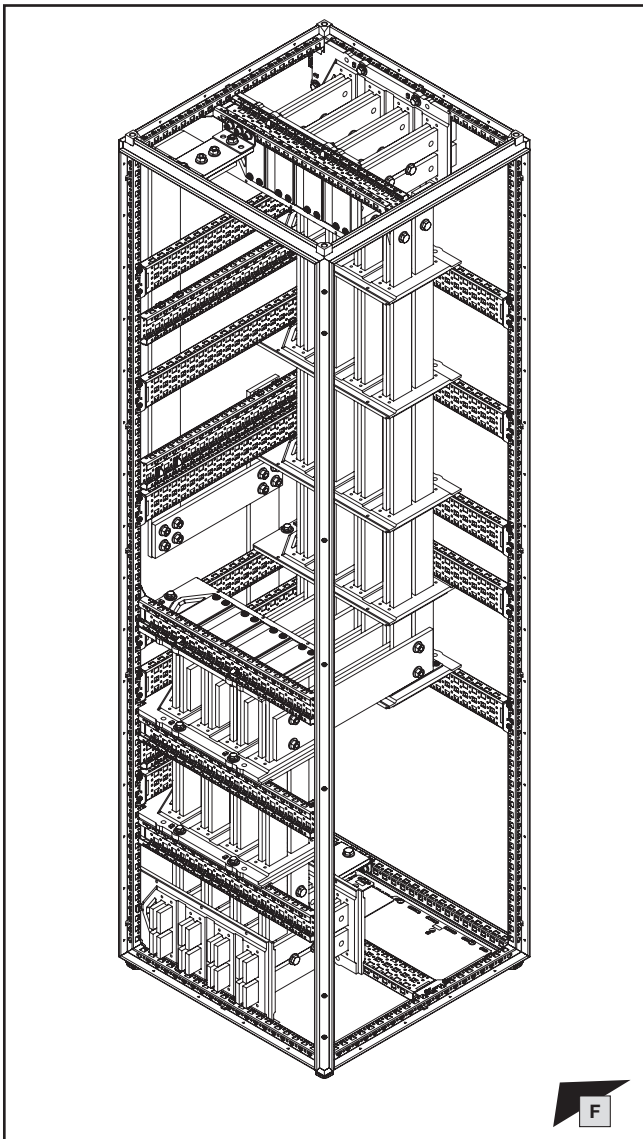

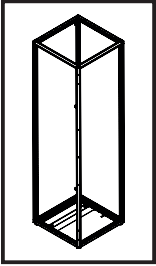

- 1. Montage Hochführungsfeld – Einbaulage Boden auf Dach
- 1. Fitting the riser section – Mounting position: Base section to roof
- 1. Zone de montage vertical – position base vers toit

- 1.2 Vorbereitung Modulschrank
- 1.2 Preparing the modular enclosure
- 1.2 Préparation de l'armoire modulaire

Montageanleitung VX25 Ri4Power – Schalt- und Energieverteilanlagen-System
 Assembly instructions VX25 Ri4Power – Switchgear and power distribution system
 Notice de montage VX25 Ri4Power – Distribution de courant

DE/EN/FR



Hinweis / Note / Remarque

Vorbereitende Arbeiten: siehe o. g. Anleitung, Kapitel „Demontage Flachteile“ und „Vorbereitung Montage Frontblenden“.

Preparatory work: see above mentioned assembly instructions, chapter "Dismantling panels" and "Preparation of mounting front trim panels".

Pour les travaux préliminaires, voir les chapitres « Démontage des pièces plates » et « Préparation du montage des faces avant » de la notice de montage ci-dessus.



Hinweis / Note / Remarque

Für Schutzzeigenschaft Störlichtbogenklasse A/B Montagerihenfolge in den entsprechenden Kapiteln der o. g. Anleitung beachten.

For arcing class A/B protection, please follow the assembly sequence as set out in the relevant chapters of the aforementioned assembly instructions.

Pour la protection contre les arcs électriques de catégorie A/B, suivez la séquence de montage indiquée dans les chapitres correspondantes des instructions ci-dessus.

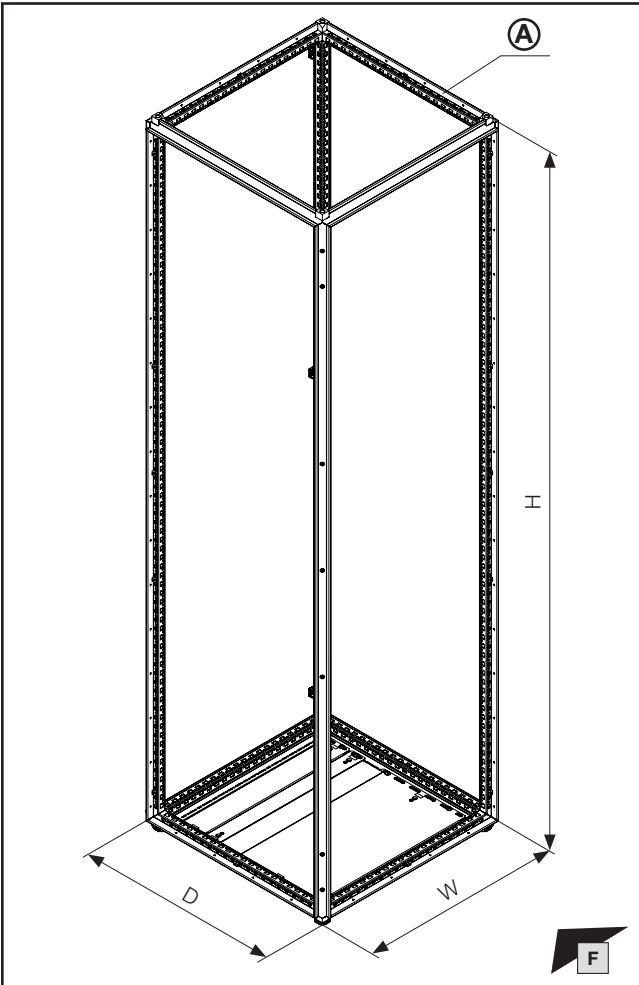

Hinweis / Note / Remarque

Die Angaben „W“ (Breite), „H“ (Höhe) und „D“ (Tiefe) der Schränke beziehen sich jeweils auf die nominalen Abmessungen der Schränke.

The information "W" (width), "H" (height) and "D" (depth) each refer to the nominal dimensions of the enclosures.

Les informations « W » (largeur), « H » (hauteur) et « D » (profondeur) se réfèrent chacune aux dimensions nominales des armoires.



Hinweis / Note / Remarque

Alternativ: Basisschrank aus Produktauswahl „Anreih-Schranksystem VX25“.

Option: Basic enclosure from the "baying enclosure system VX25" product selection.

Option : armoire électrique juxtaposable VX25 classique.

W mm	H mm	D mm	A Best.-Nr. Model No. Référence
600	2000	600	9680.606
600	2000	800	9680.608
600	2200	600	9680.626
600	2200	800	9680.628

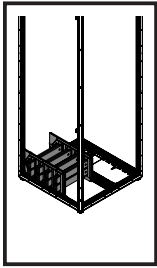

1. Montage Hochführungsfeld – Einbaulage Boden auf Dach
 1. Fitting the riser section – Mounting position: Base section to roof
 1. Zone de montage vertical – position base vers toit

- 1.3 Montage des unteren Hauptschienensystems
 1.3 Fitting the lower main busbar system
 1.3 Montage des jeux de barres principaux inférieurs

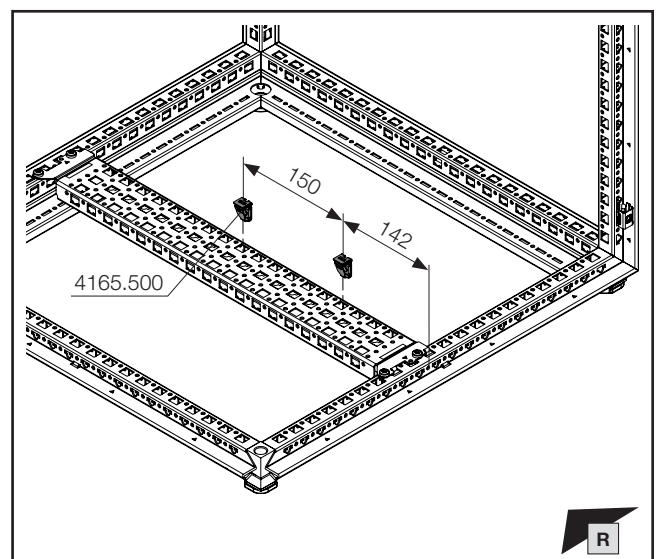
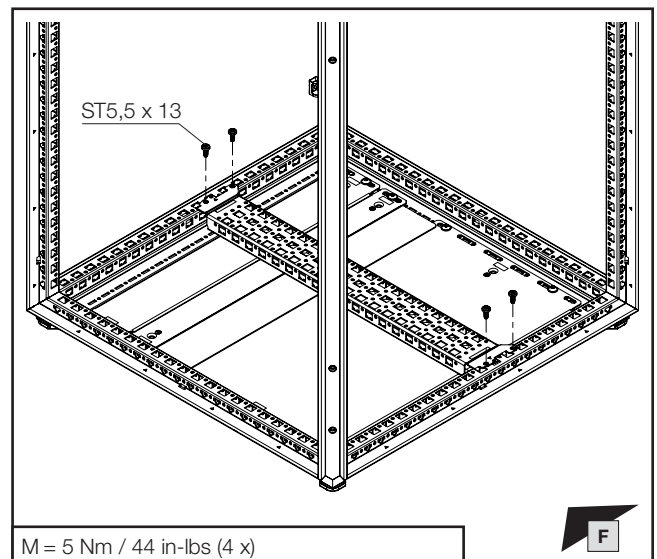
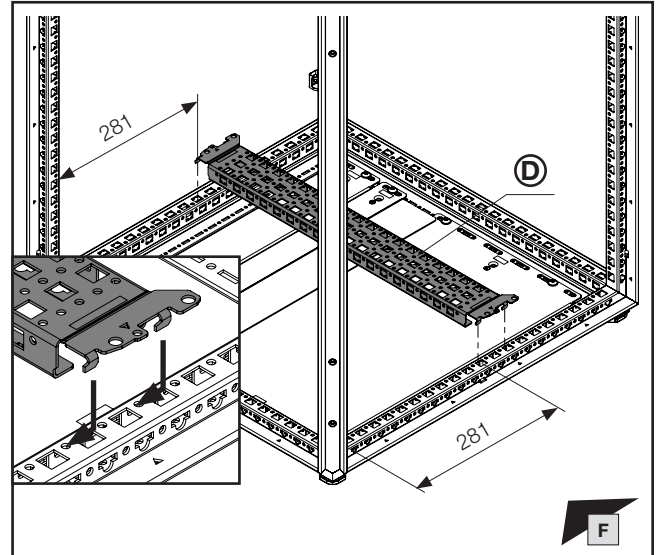
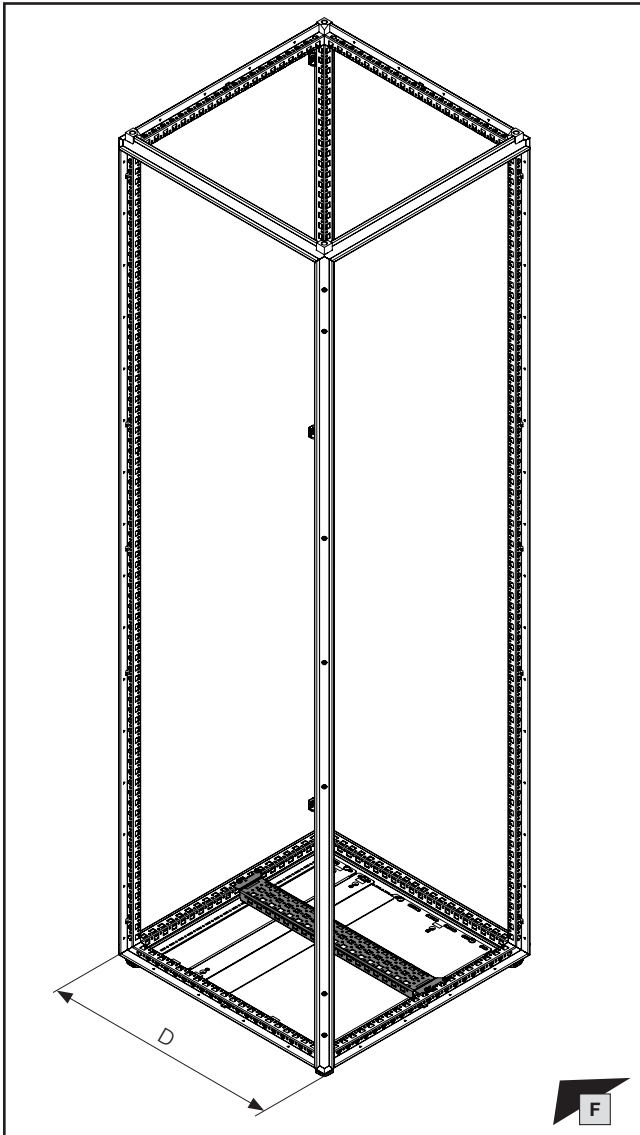

D mm	Best.-Nr. Model No. Référence
600	8617.130
800	8617.140

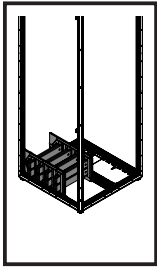

1. Montage Hochführungsfeld – Einbaulage Boden auf Dach
 1. Fitting the riser section – Mounting position: Base section to roof
 1. Zone de montage vertical – position base vers toit

- 1.3 Montage des unteren Hauptschienensystems
 1.3 Fitting the lower main busbar system
 1.3 Montage des jeux de barres principaux inférieurs

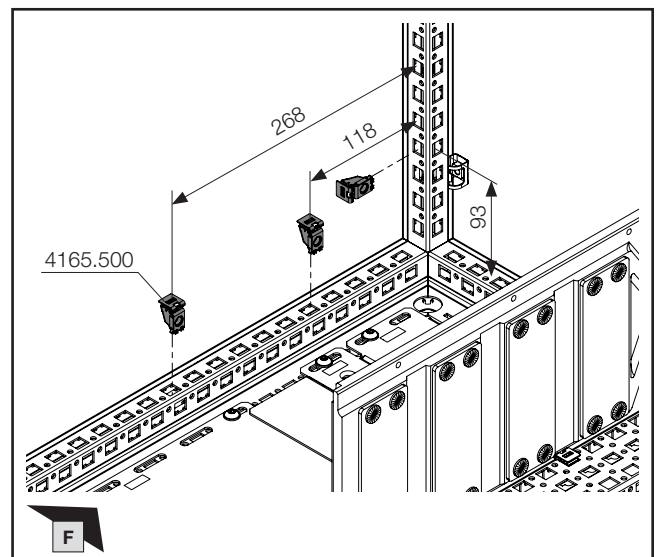
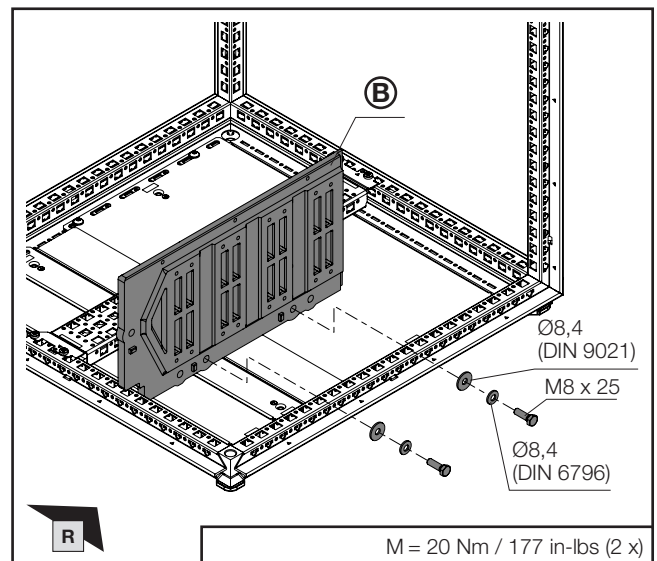
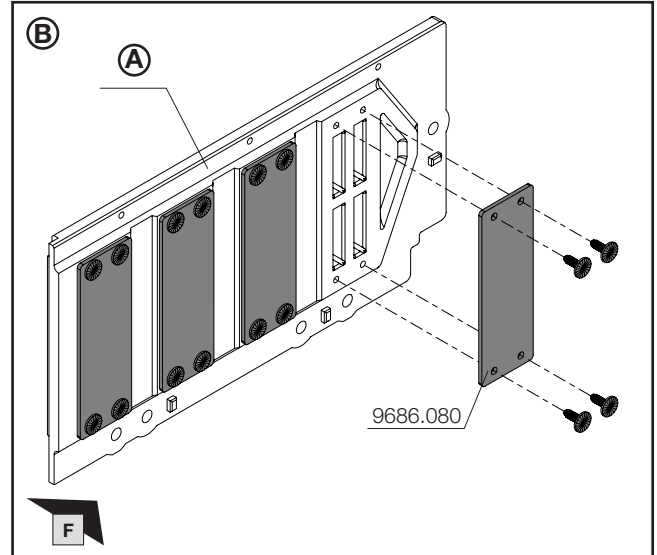
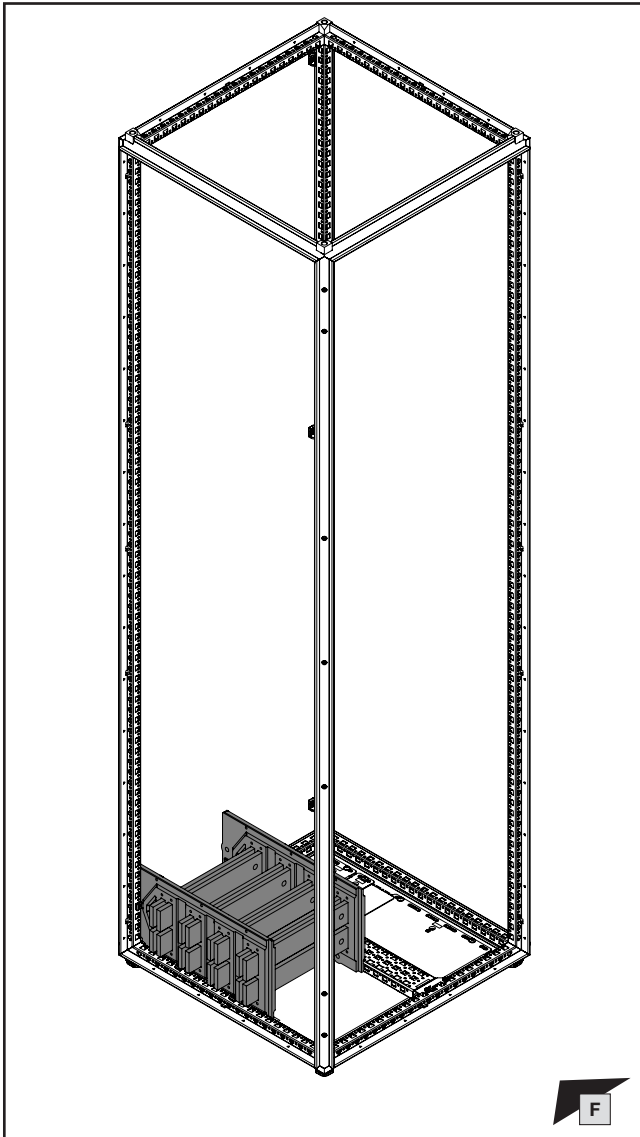

Sammelschiene Abmessung mm Busbar dimension mm Dimensions de la barre mm	Anreihung Baying Juxtaposition	(A) Best.-Nr. Model No. Référence
30 x 10	×	9686.010
50 x 10	×	9686.040

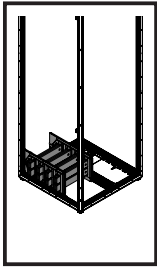

1. Montage Hochführungsfeld – Einbaulage Boden auf Dach
1. Fitting the riser section – Mounting position: Base section to roof
1. Zone de montage vertical – position base vers toit

- 1.3 Montage des unteren Hauptschienensystems
- 1.3 Fitting the lower main busbar system
- 1.3 Montage des jeux de barres principaux inférieurs

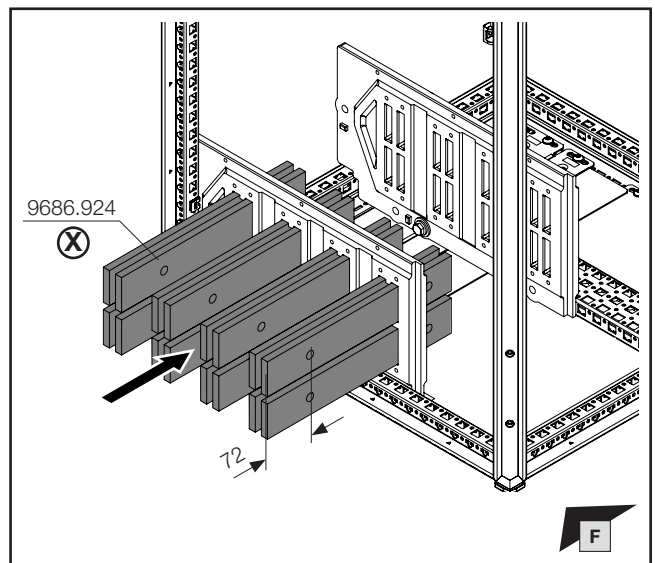
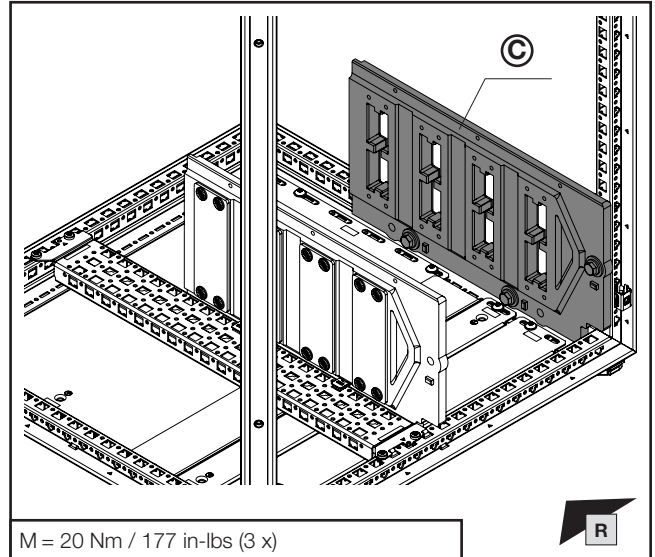
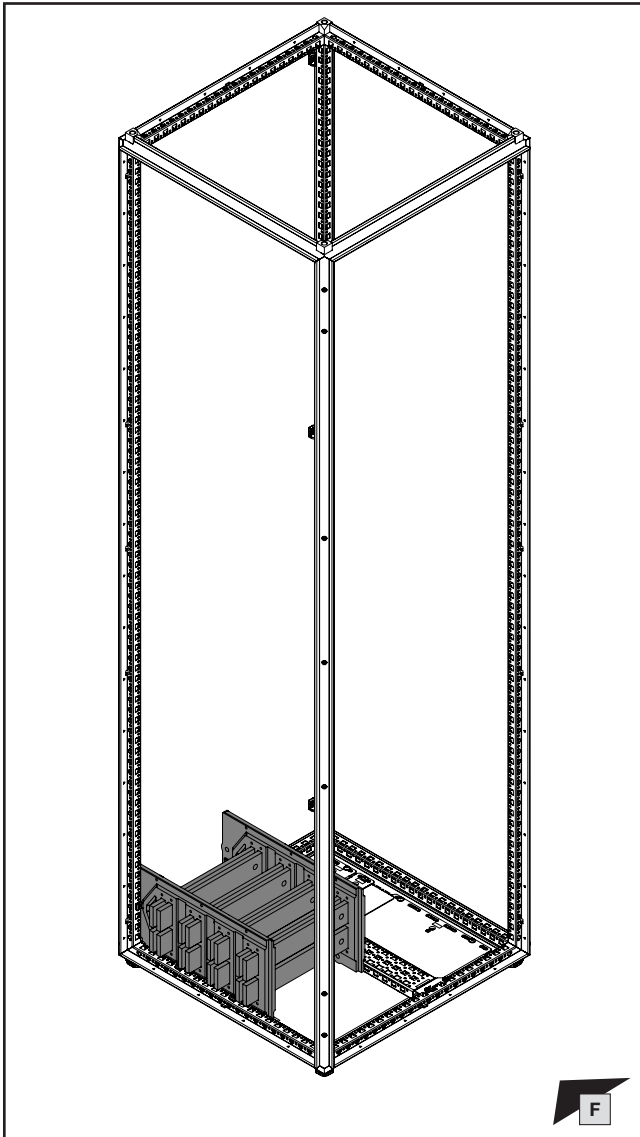

Hinweis / Note / Remarque (X)

Die Länge der Sammelschienen wird mit Hilfe der Online-Berechnungssoftware „RiPower“ im Niederspannungsschaltanlagen Konfigurator ermittelt.

The length of the busbars is determined using the online calculation software "RiPower" in the low-voltage switchgear configurator.

La longueur des jeux de barres est déterminée à l'aide du logiciel de calcul en ligne « RiPower » du configurateur de TGBT.



RiPower

Sammelschiene Abmessung mm Busbar dimension mm Dimensions de la barre mm	Anreihung Baying Juxtaposition	© Best.-Nr. Model No. Référence
30 x 10	✓	9686.000
50 x 10	✓	9686.030

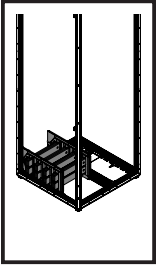

- 1. Montage Hochführungsfeld – Einbaulage Boden auf Dach
- 1. Fitting the riser section – Mounting position: Base section to roof
- 1. Zone de montage vertical – position base vers toit

- 1.3 Montage des unteren Hauptschienensystems
- 1.3 Fitting the lower main busbar system
- 1.3 Montage des jeux de barres principaux inférieurs

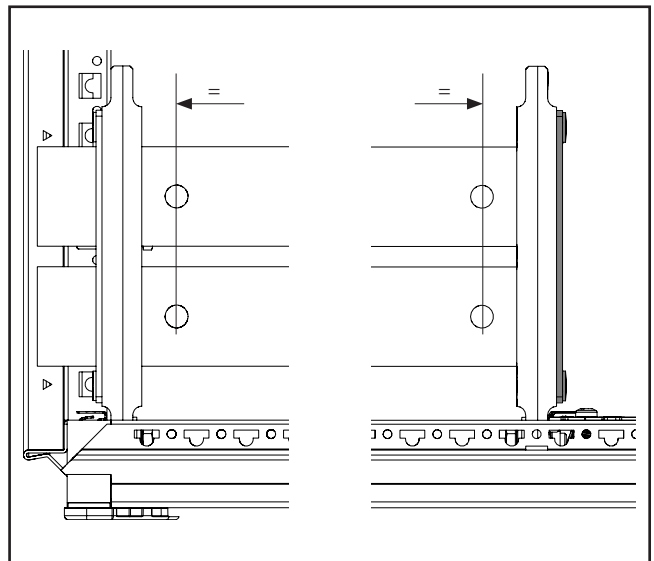
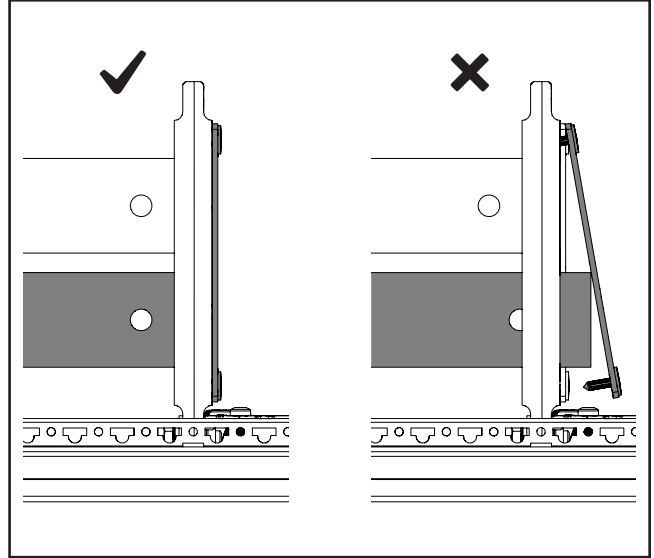
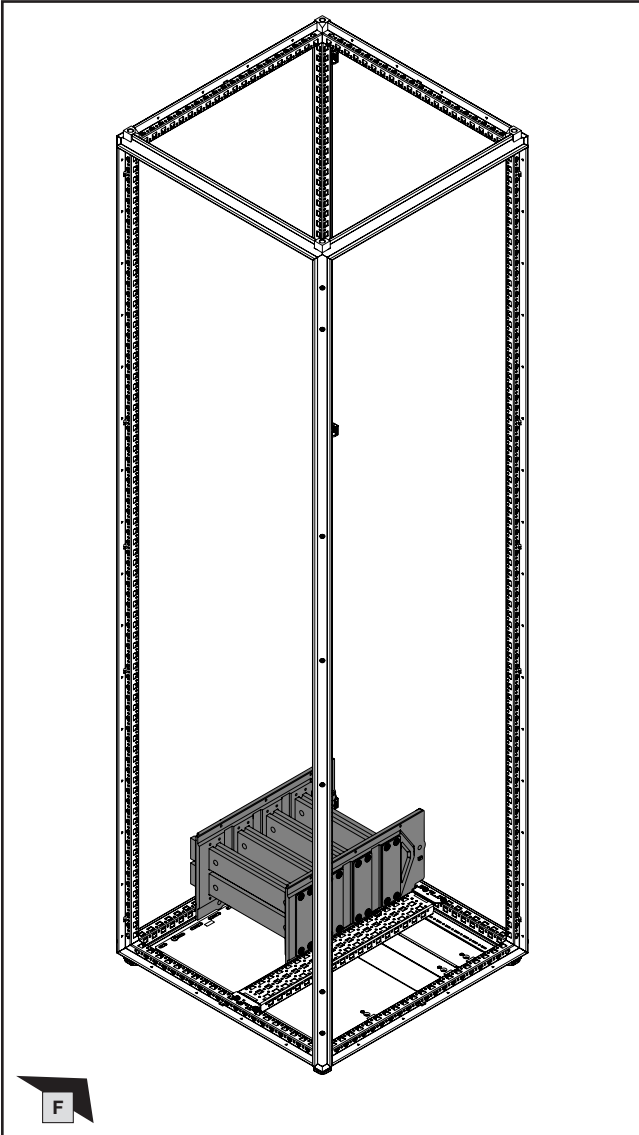

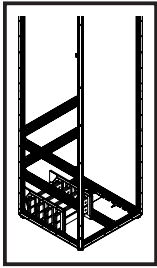

1. Montage Hochführungsfeld – Einbaulage Boden auf Dach
1. Fitting the riser section – Mounting position: Base section to roof
1. Zone de montage vertical – position base vers toit

- 1.4 Montage untere System-Chassis
- 1.4 Fitting the lower punched sections with mounting flanges
- 1.4 Montage sous rails de montage

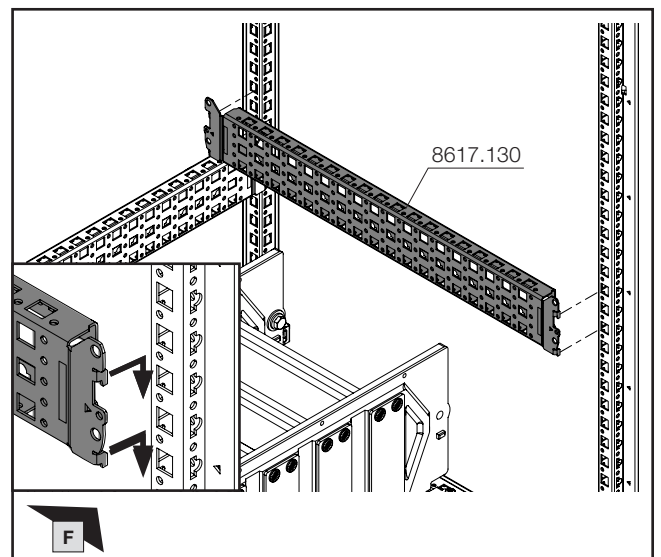
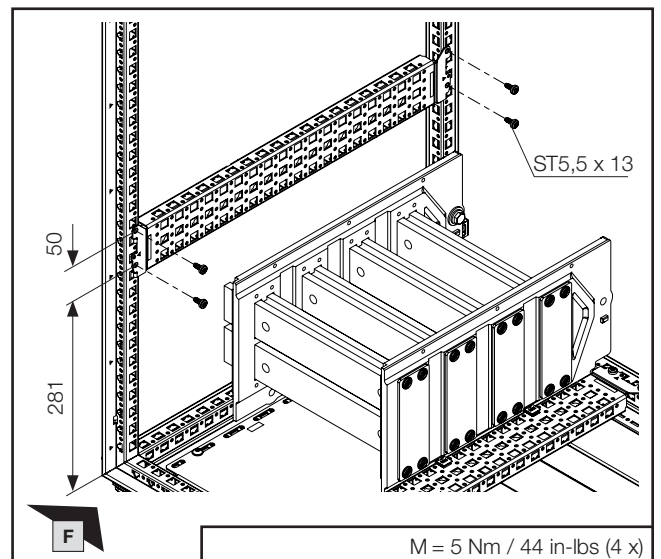
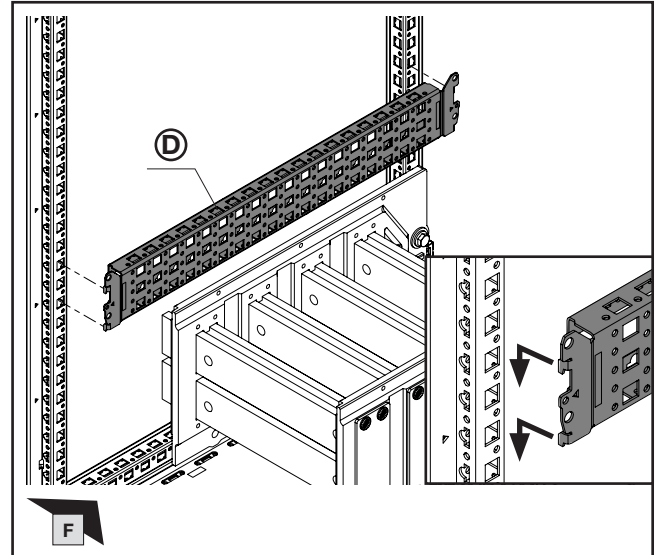
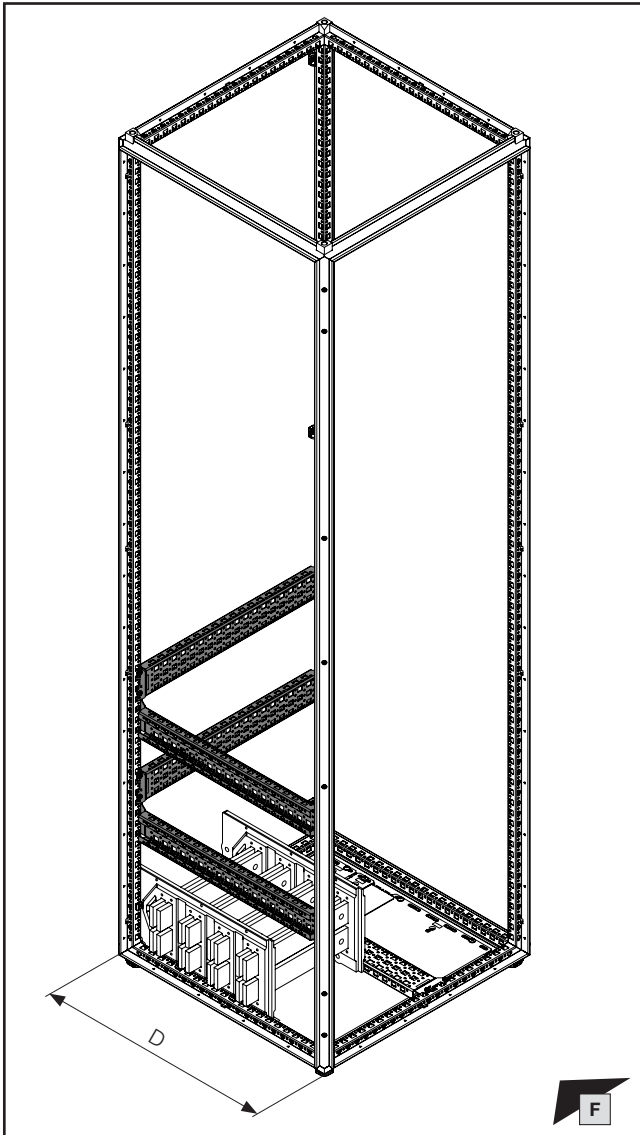

D mm	 Best.-Nr. Model No. Référence
600	8617.130
800	8617.140

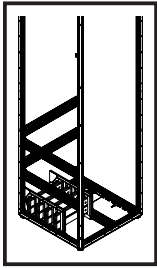

1. Montage Hochführungsfeld – Einbaulage Boden auf Dach
1. Fitting the riser section – Mounting position: Base section to roof
1. Zone de montage vertical – position base vers toit

- 1.4 Montage untere System-Chassis
- 1.4 Fitting the lower punched sections with mounting flanges
- 1.4 Montage sous rails de montage

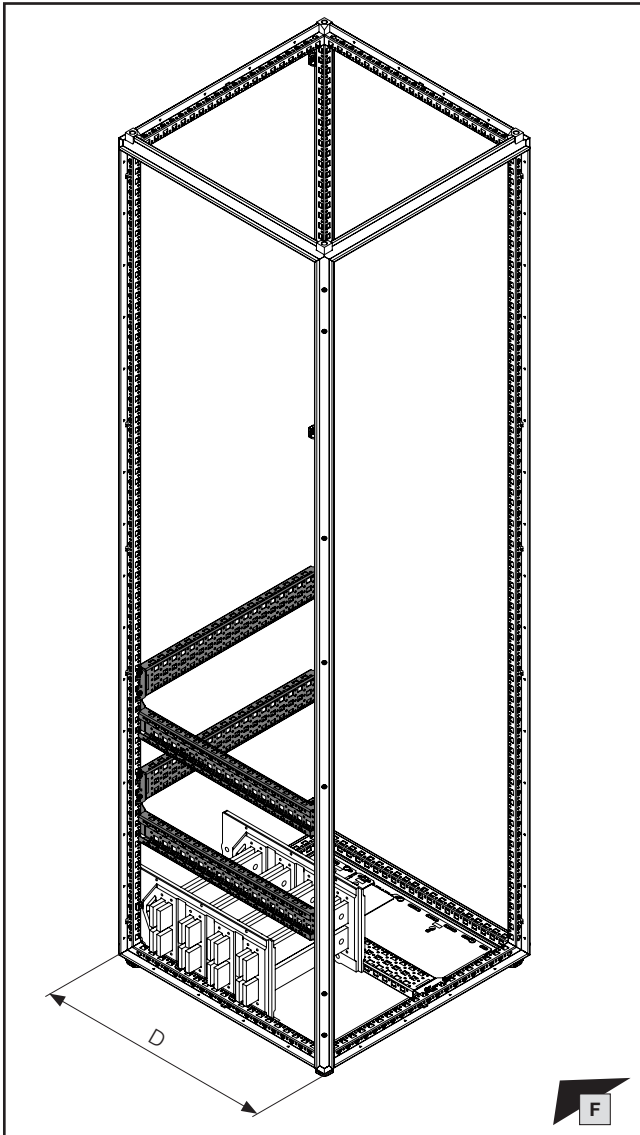

D mm	Best.-Nr. Model No. Référence
600	8617.130
800	8617.140

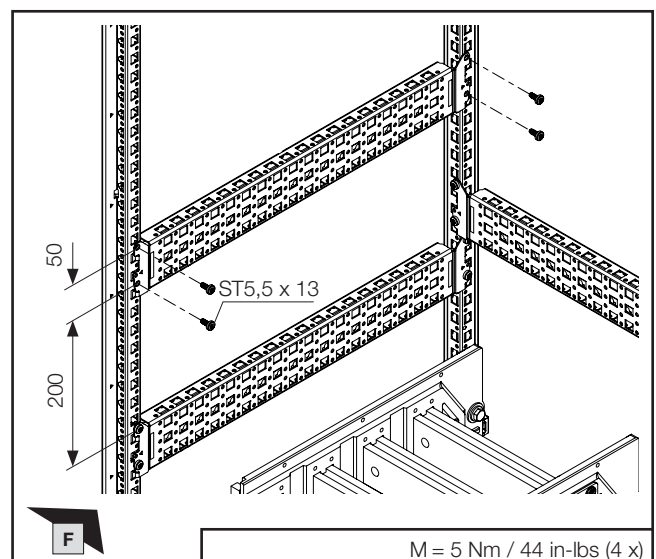
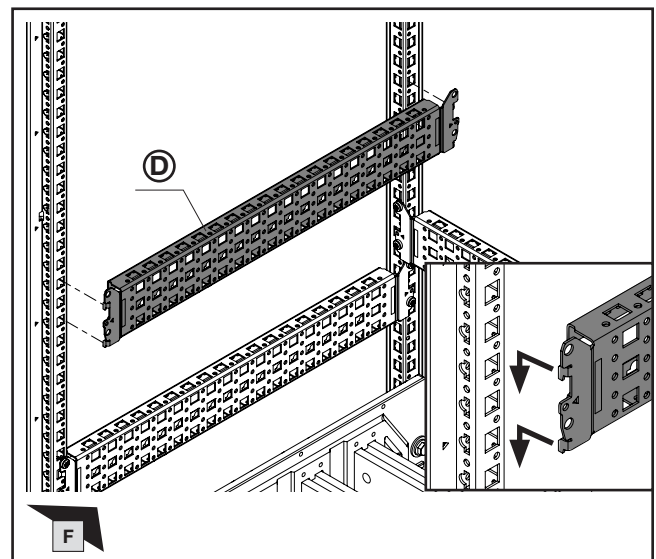
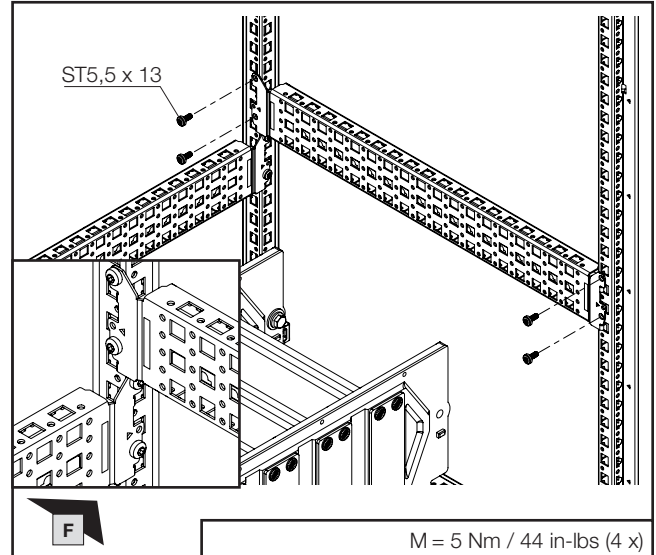

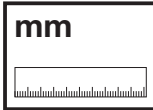
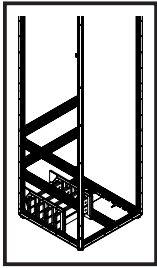

1. Montage Hochführungsfeld – Einbaulage Boden auf Dach
1. Fitting the riser section – Mounting position: Base section to roof
1. Zone de montage vertical – position base vers toit

- 1.4 Montage untere System-Chassis
- 1.4 Fitting the lower punched sections with mounting flanges
- 1.4 Montage sous rails de montage

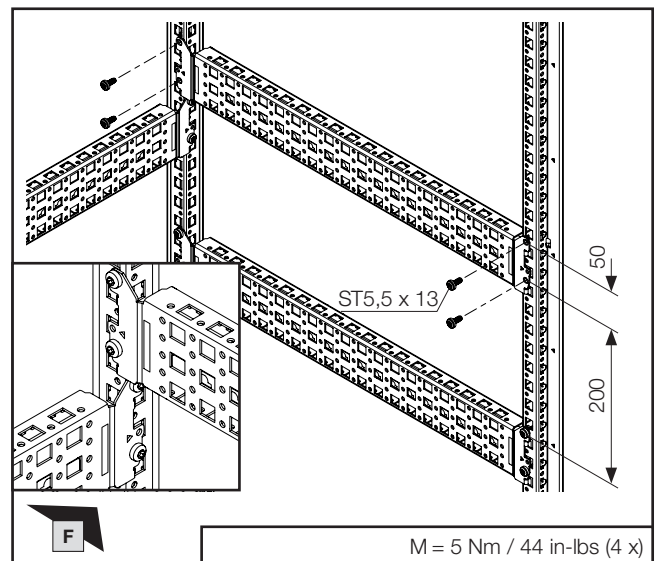
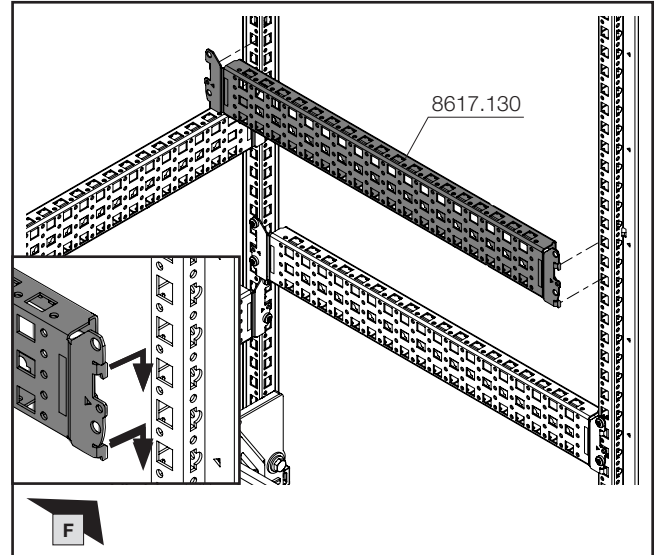
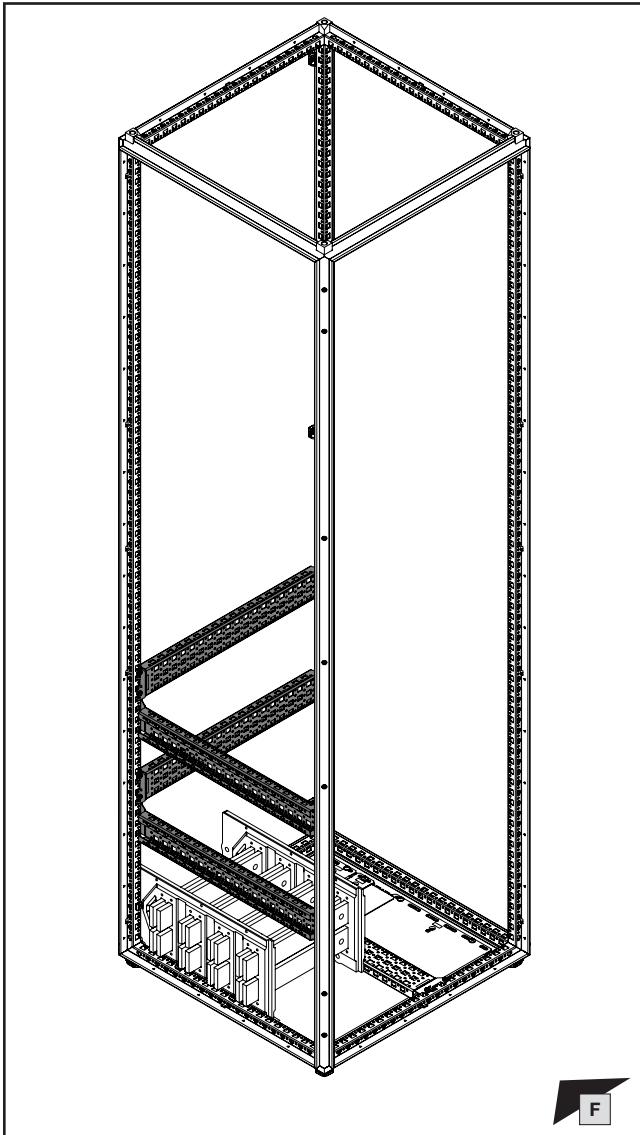

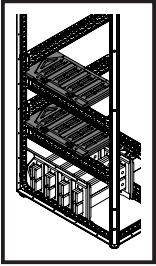

1. Montage Hochführungsfeld – Einbaulage Boden auf Dach
 1. Fitting the riser section – Mounting position: Base section to roof
 1. Zone de montage vertical – position base vers toit

- 1.5 Montage untere Sammelschienenhalter vertikal
 1.5 Fitting the lower busbar supports, vertical
 1.5 Montage des supports de jeux de barres verticaux inférieurs

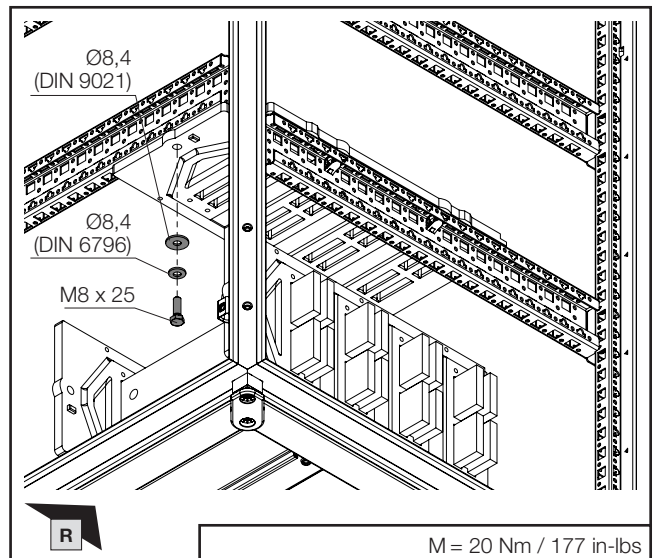
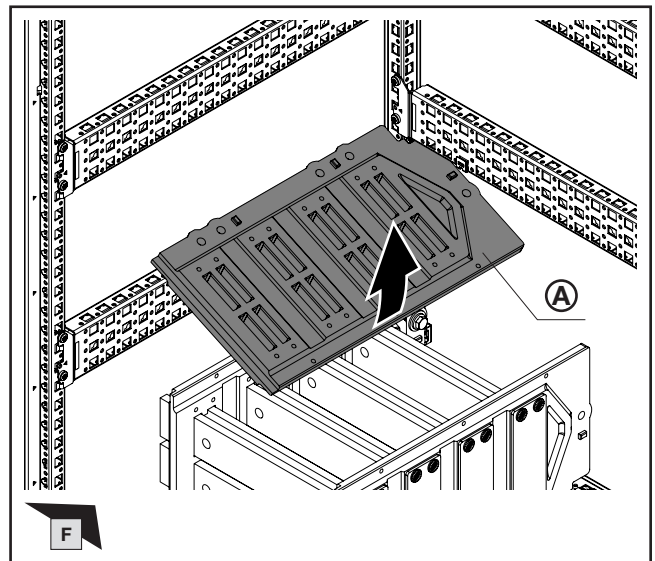
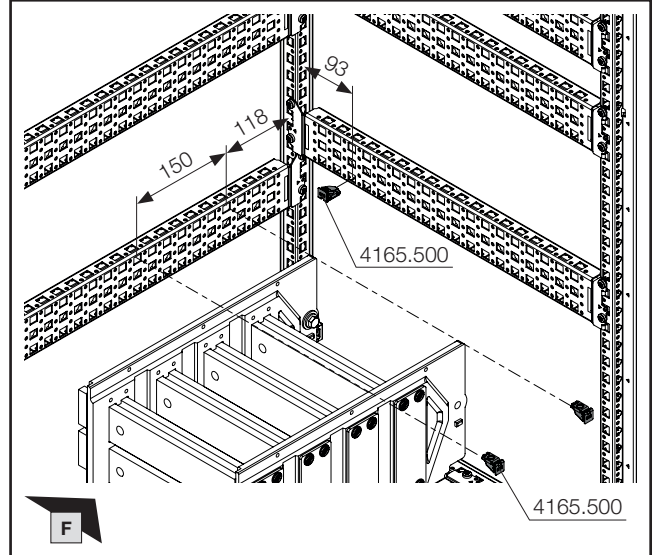
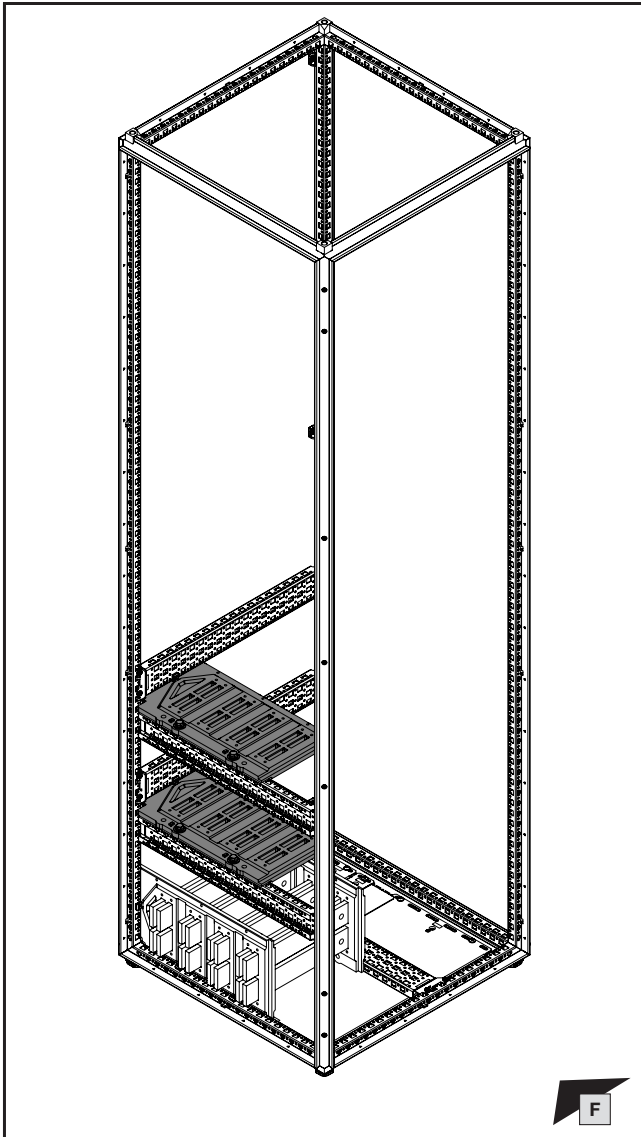

Sammelschiene Abmessung mm Busbar dimension mm Dimensions de la barre mm	Anreihung Baying Juxtaposition	A Best.-Nr. Model No. Référence
30 x 10	×	9686.010
50 x 10	×	9686.040

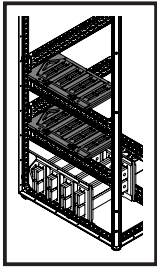

1. Montage Hochführungsfeld – Einbaulage Boden auf Dach
1. Fitting the riser section – Mounting position: Base section to roof
1. Zone de montage vertical – position base vers toit

- 1.5 Montage untere Sammelschienenhalter vertikal
- 1.5 Fitting the lower busbar supports, vertical
- 1.5 Montage des supports de jeux de barres verticaux inférieurs

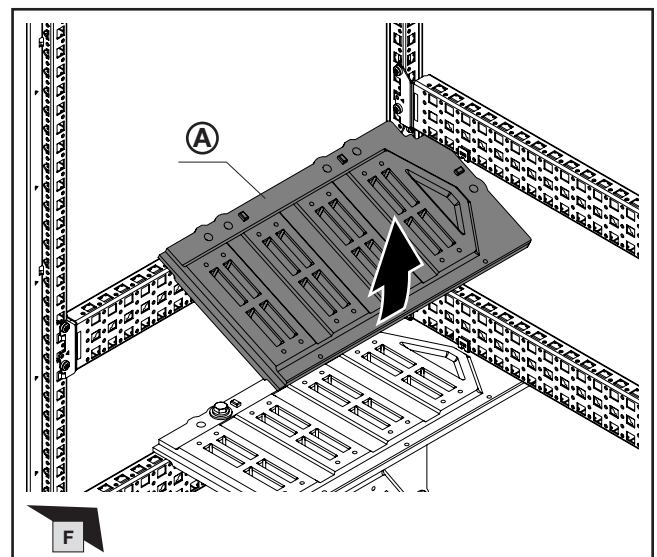
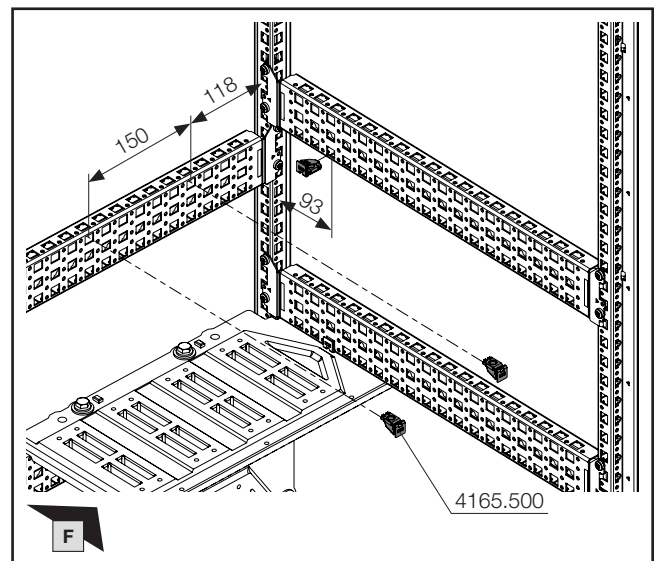
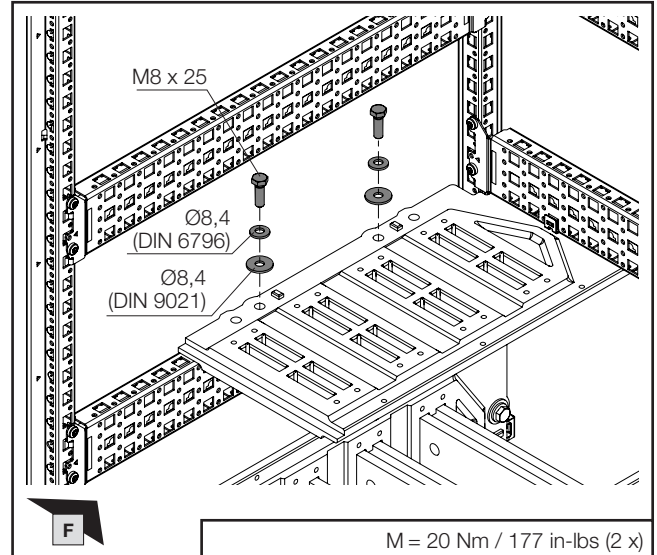
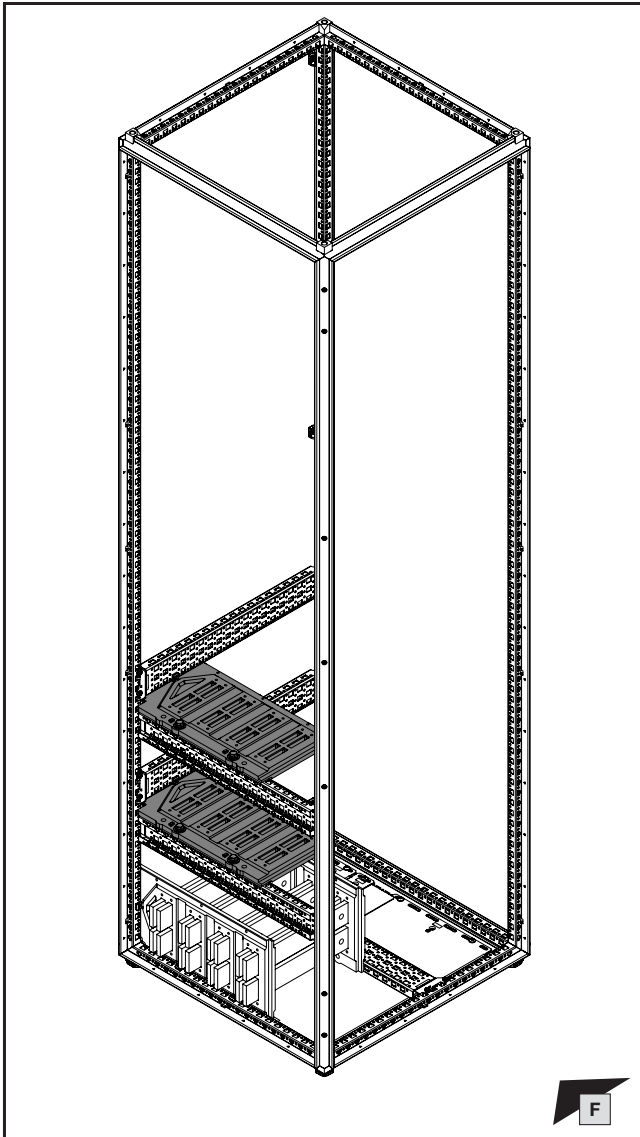

Sammelschiene Abmessung mm Busbar dimension mm Dimensions de la barre mm	Anreihung Baying Juxtaposition	A Best.-Nr. Model No. Référence
30 x 10	×	9686.010
50 x 10	×	9686.040

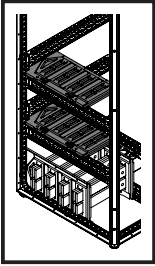

SW13



DE EN FR



1. Montage Hochführungsfeld – Einbaulage Boden auf Dach
1. Fitting the riser section – Mounting position: Base section to roof
1. Zone de montage vertical – position base vers toit

- 1.5 Montage untere Sammelschienenhalter vertikal
- 1.5 Fitting the lower busbar supports, vertical
- 1.5 Montage des supports de jeux de barres verticaux inférieurs

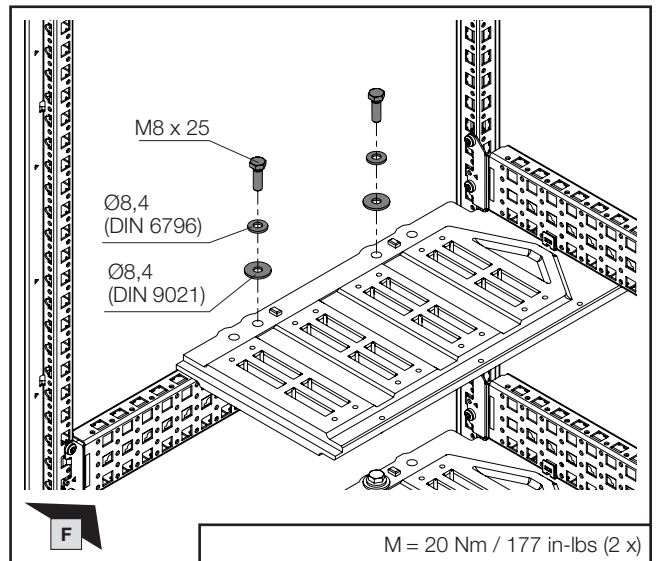
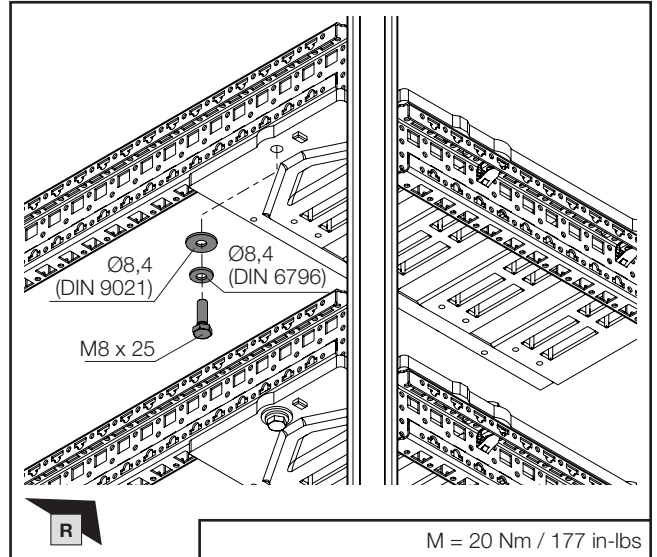
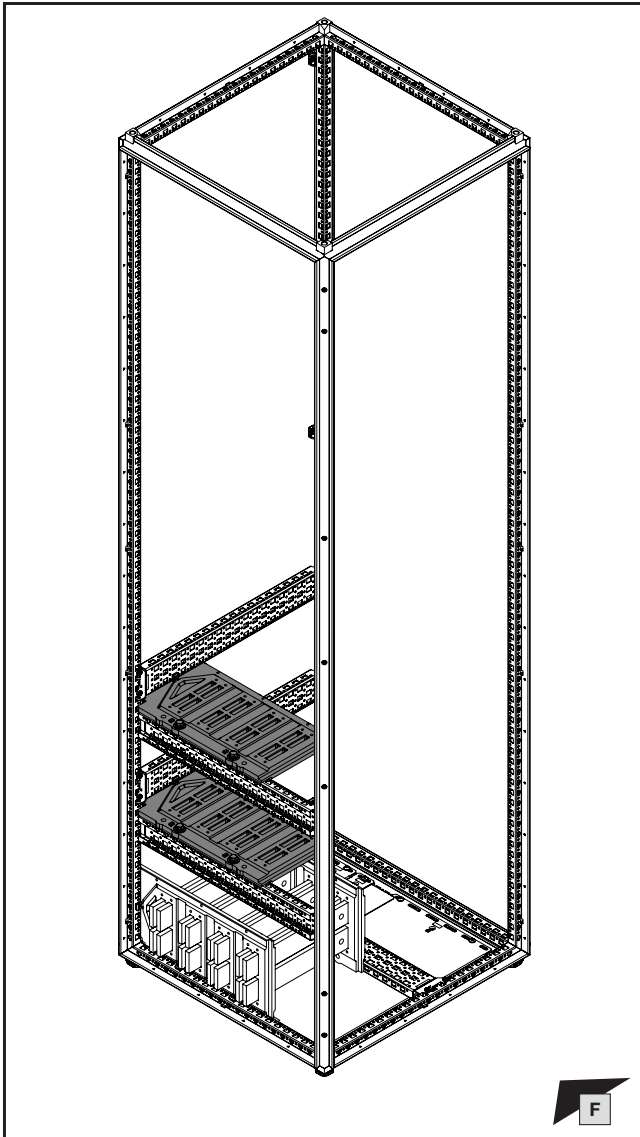

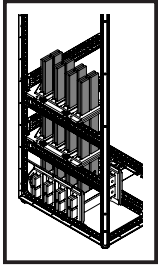

1. Montage Hochführungsfeld – Einbaulage Boden auf Dach
1. Fitting the riser section – Mounting position: Base section to roof
1. Zone de montage vertical – position base vers toit

- 1.6 Einbringung untere vertikale Verteilsammelschienen
- 1.6 Incorporating the lower vertical distribution busbars
- 1.6 Introduction des jeux de barres de distribution verticaux inférieurs

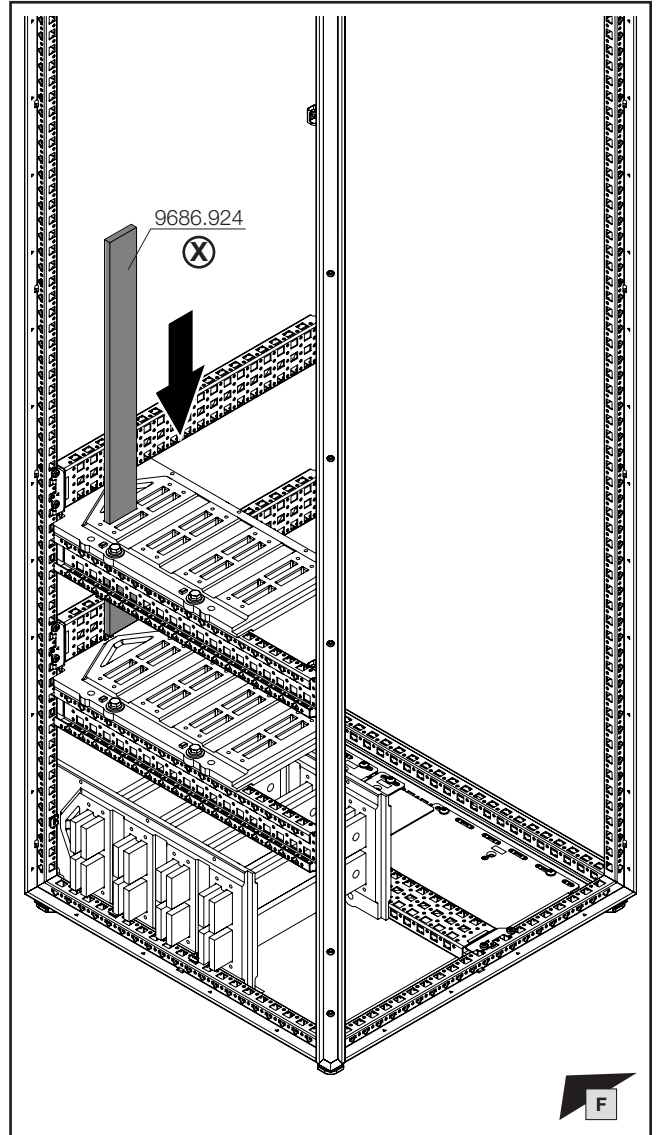
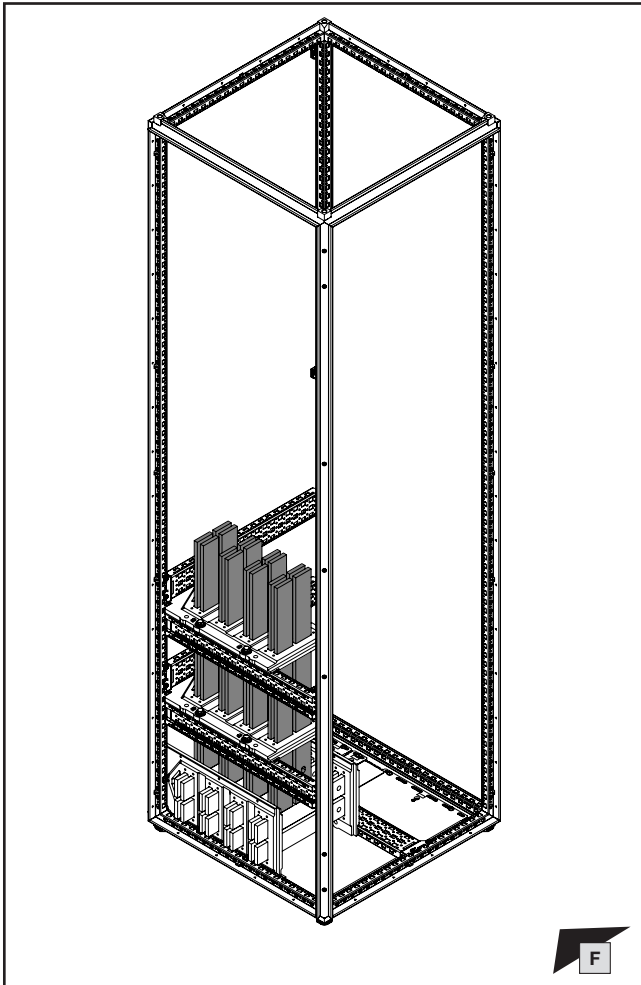

Hinweis / Note / Remarque (X)

Die Länge der Sammelschienen wird mit Hilfe der Online-Berechnungssoftware „RiPower“ im Niederspannungsschaltanlagen Konfigurator ermittelt.

The length of the busbars is determined using the online calculation software "RiPower" in the low-voltage switchgear configurator.

La longueur des jeux de barres est déterminée à l'aide du logiciel de calcul en ligne « RiPower » du configurateur de TGBT.



RiPower

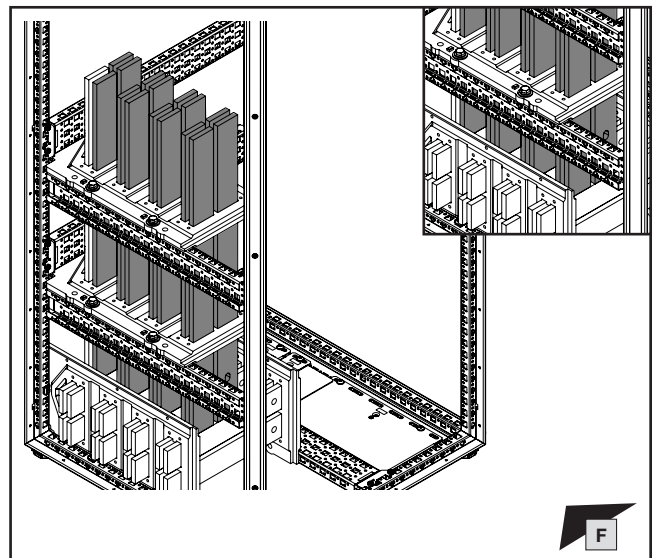

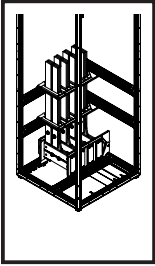

SW16/
SW17

DE EN FR



1. Montage Hochführungsfeld – Einbaulage Boden auf Dach
1. Fitting the riser section – Mounting position: Base section to roof
1. Zone de montage vertical – position base vers toit

- 1.7 Anbindung unteres vertikales Verteilsammelschienen-system
- 1.7 Connecting the lower vertical multi-terminal busbar system
- 1.7 Connexion aux jeux de barres de distribution verticaux inférieurs

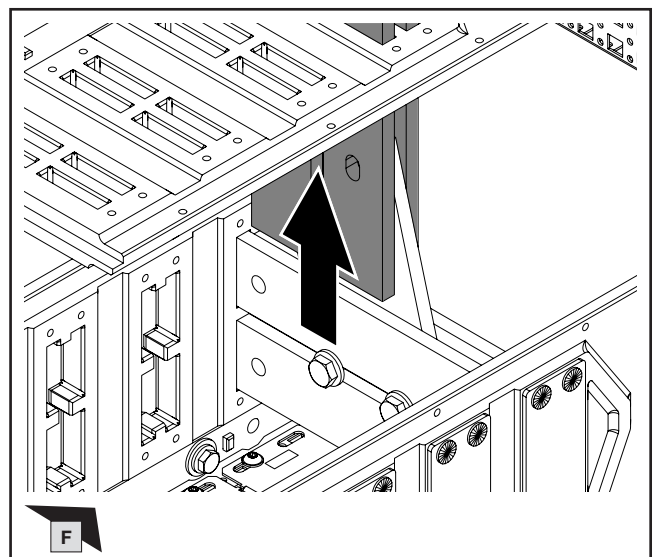
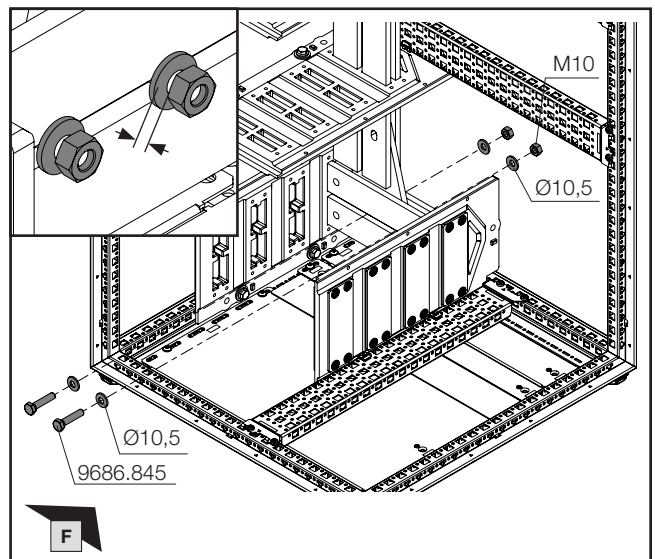
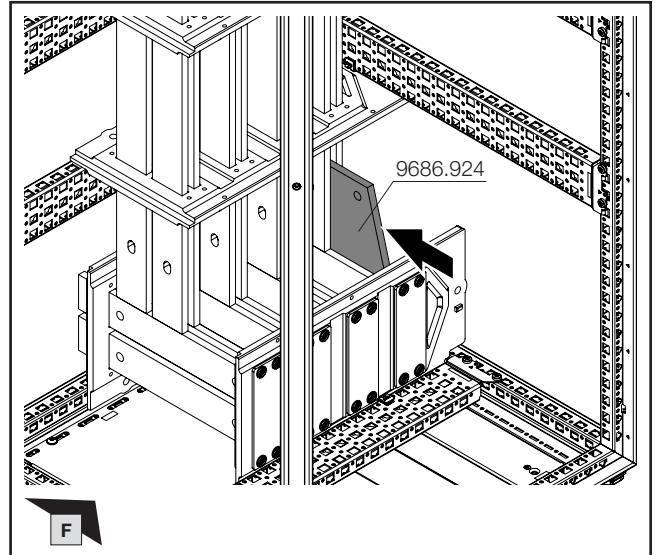
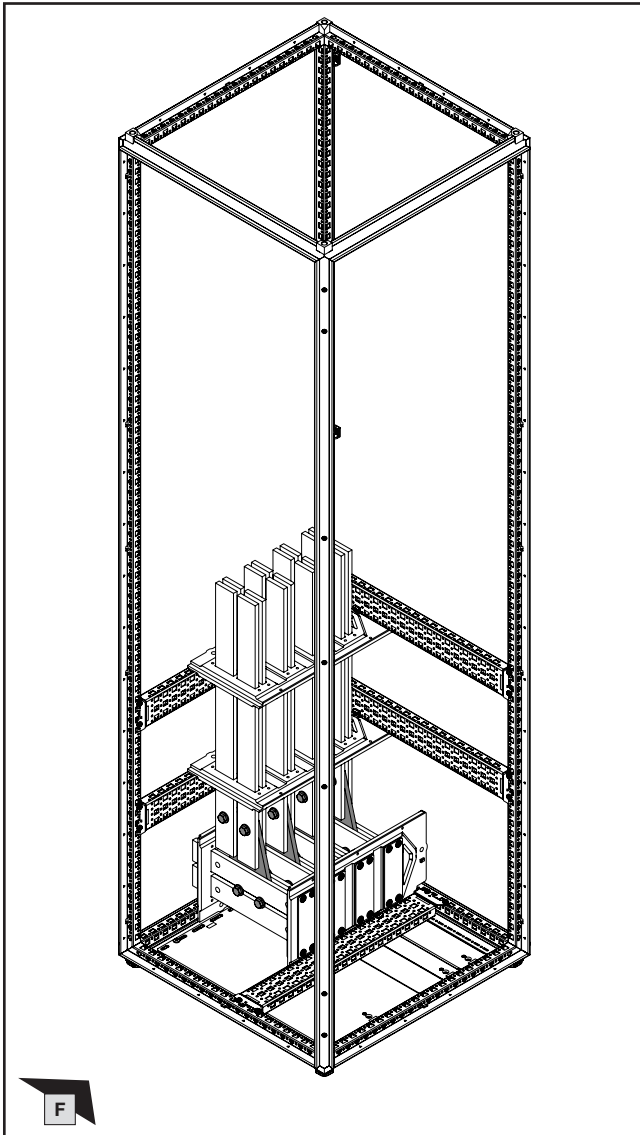

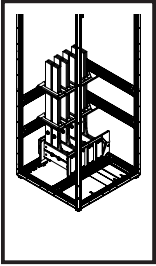

SW16/
SW17

DE EN FR



1. Montage Hochführungsfeld – Einbaulage Boden auf Dach
1. Fitting the riser section – Mounting position: Base section to roof
1. Zone de montage vertical – position base vers toit

- 1.7 Anbindung unteres vertikales Verteilsammelschienen-system
- 1.7 Connecting the lower vertical multi-terminal busbar system
- 1.7 Connexion aux jeux de barres de distribution verticaux inférieurs

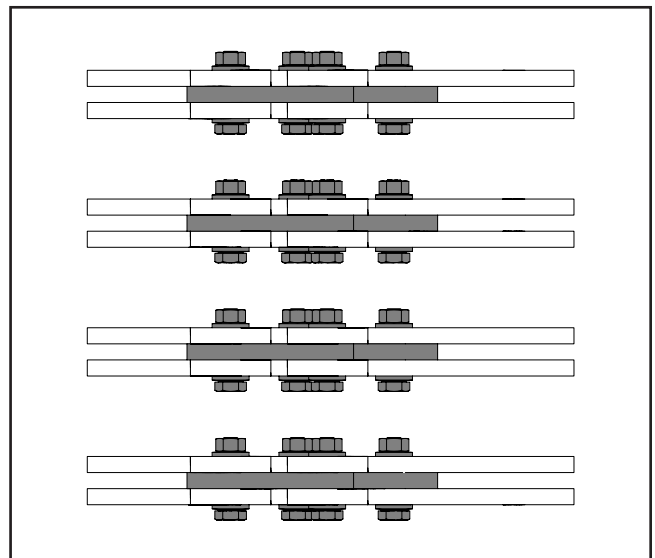
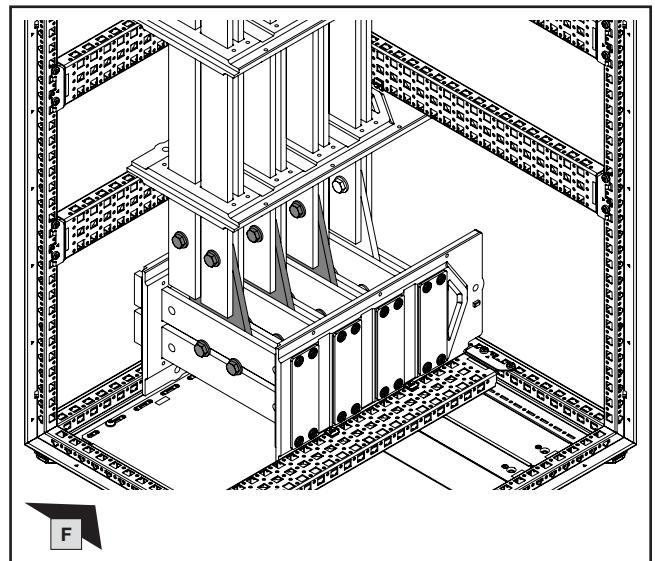
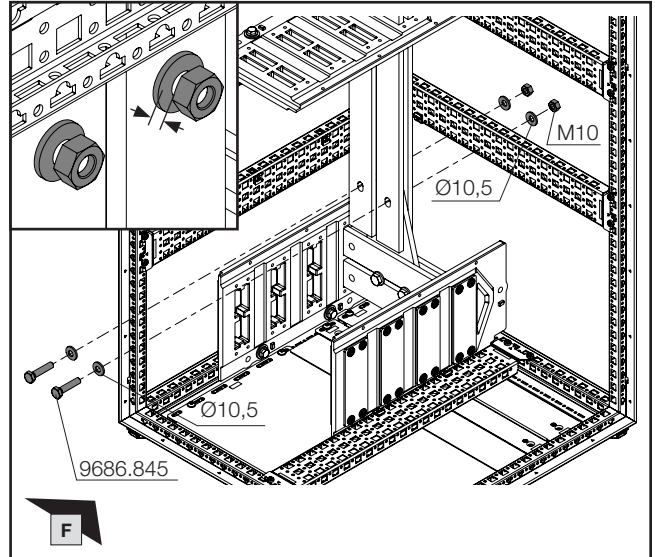
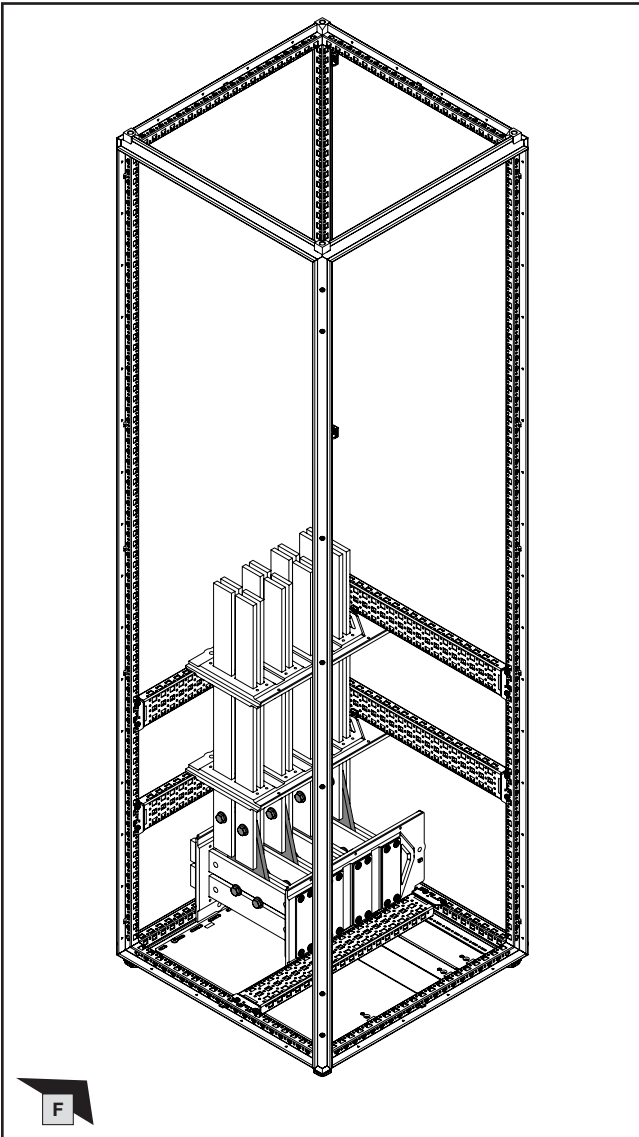

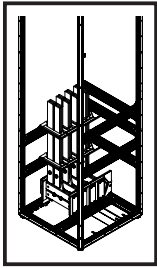

- 1. Montage Hochführungsfeld – Einbaulage Boden auf Dach
- 1. Fitting the riser section – Mounting position: Base section to roof
- 1. Zone de montage vertical – position base vers toit

- 1.8 Montage mittlere System-Chassis
- 1.8 Fitting the middle punched section with mounting flange
- 1.8 Montage du rail de montage central

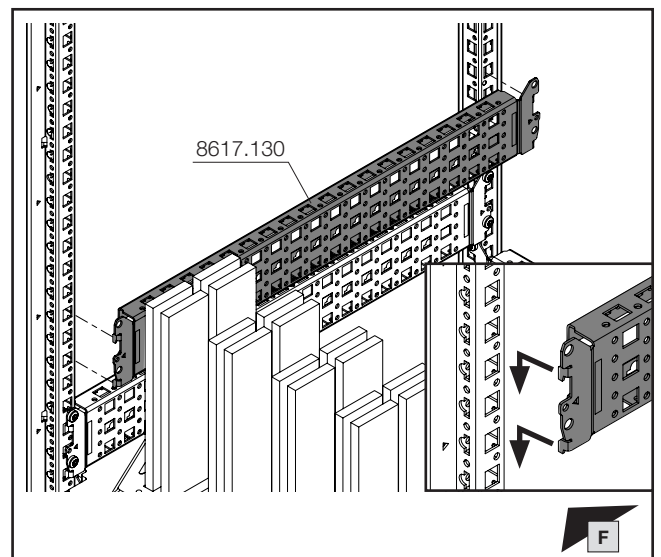
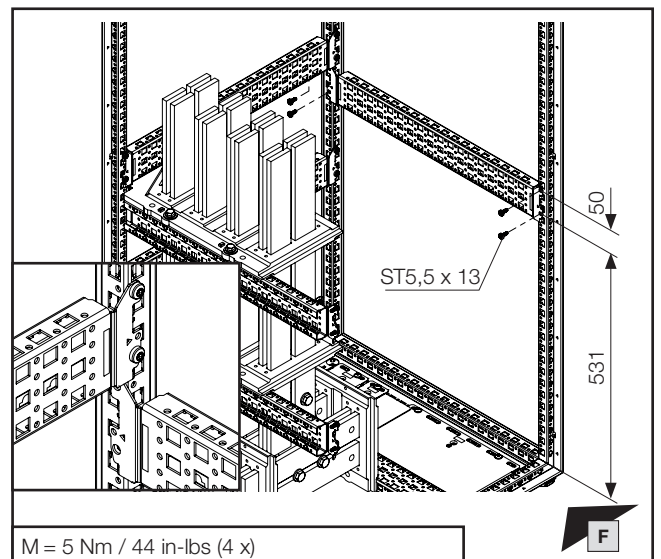
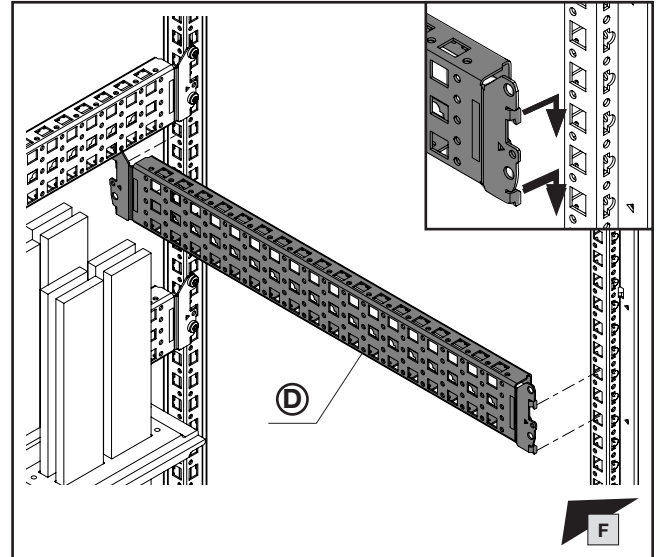
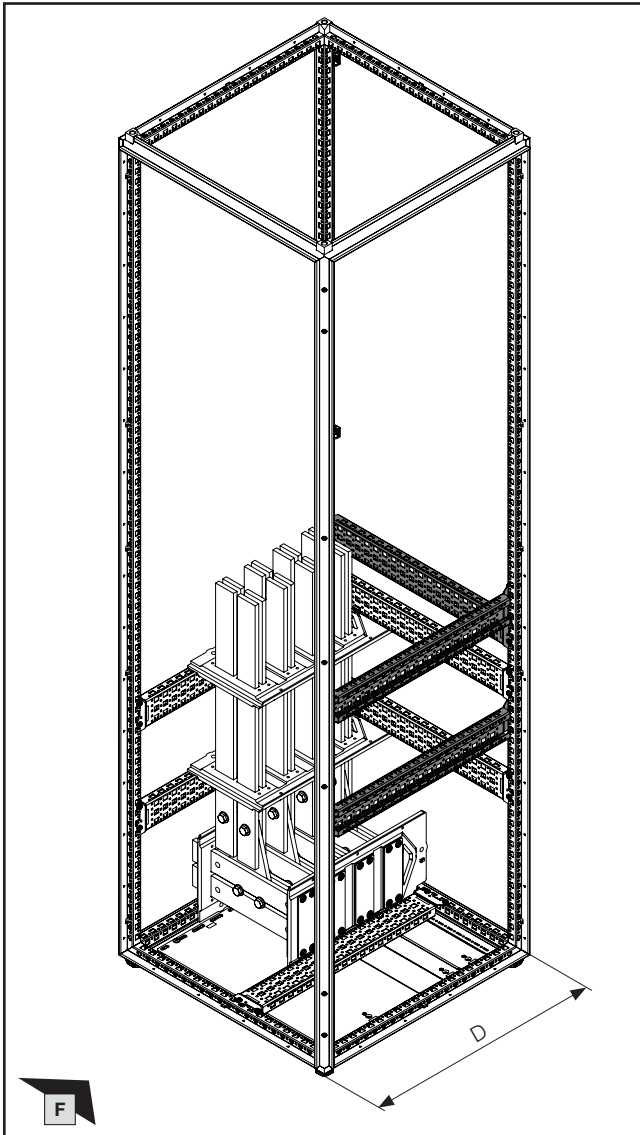

D mm	Best.-Nr. Model No. Référence
600	8617.130
800	8617.140

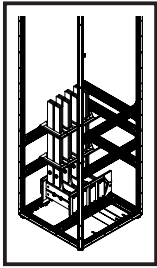

DE EN FR



1. Montage Hochführungsfeld – Einbaulage Boden auf Dach
1. Fitting the riser section – Mounting position: Base section to roof
1. Zone de montage vertical – position base vers toit

- 1.8 Montage mittlere System-Chassis
- 1.8 Fitting the middle punched section with mounting flange
- 1.8 Montage du rail de montage central

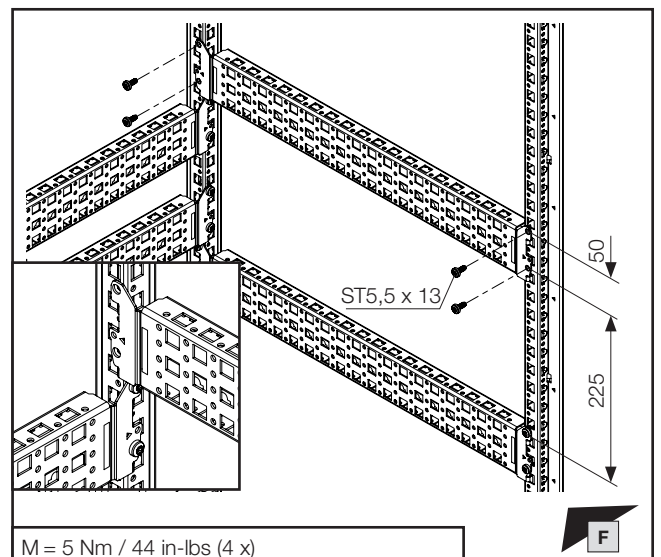
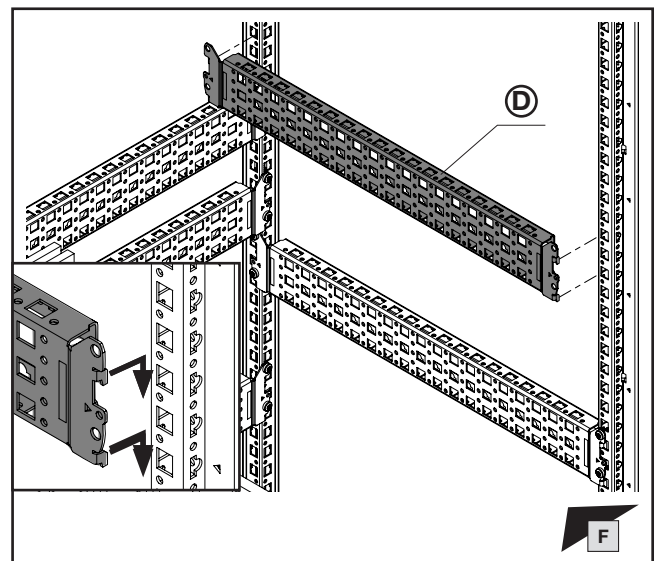
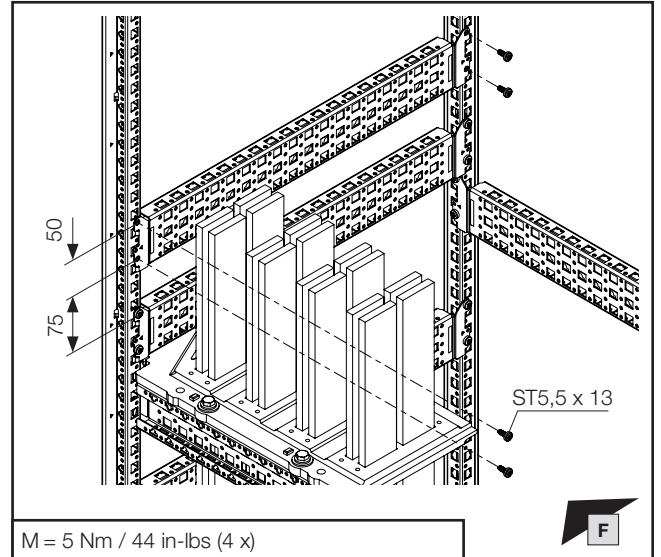
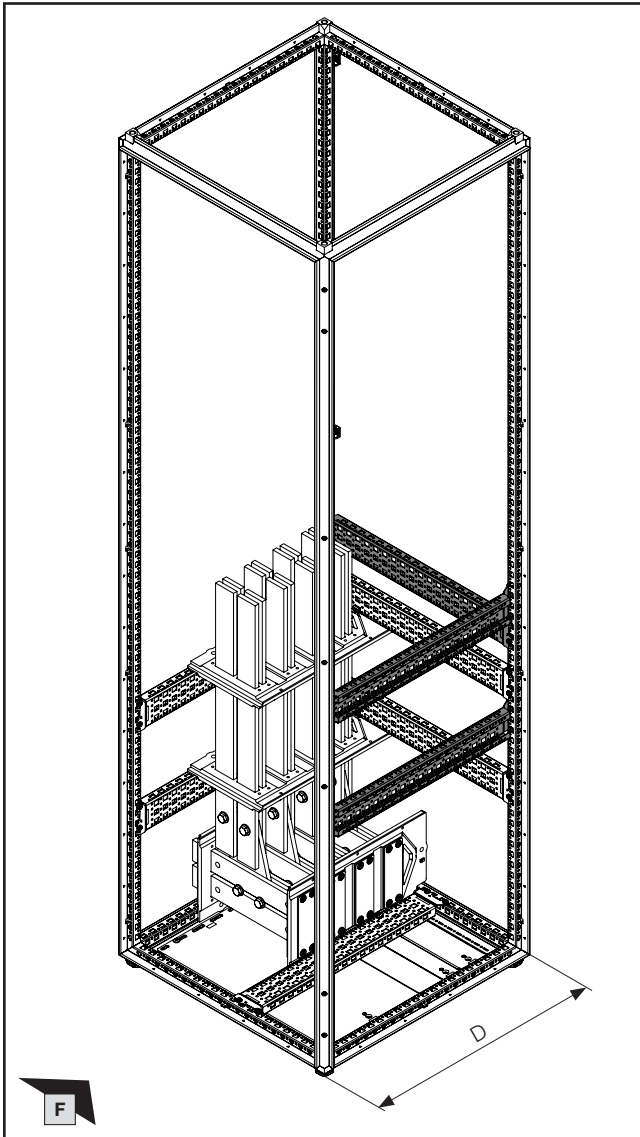

D mm	Best.-Nr. Model No. Référence
600	8617.130
800	8617.140

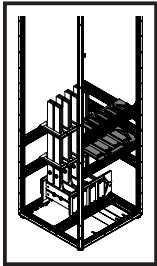

DE EN FR



1. Montage Hochführungsfeld – Einbaulage Boden auf Dach
1. Fitting the riser section – Mounting position: Base section to roof
1. Zone de montage vertical – position base vers toit

- 1.9 Montage mittlere Sammelschienenhalter vertikal
- 1.9 Fitting the middle busbar holder, vertical
- 1.9 Montage des supports centraux de jeux de barres verticaux

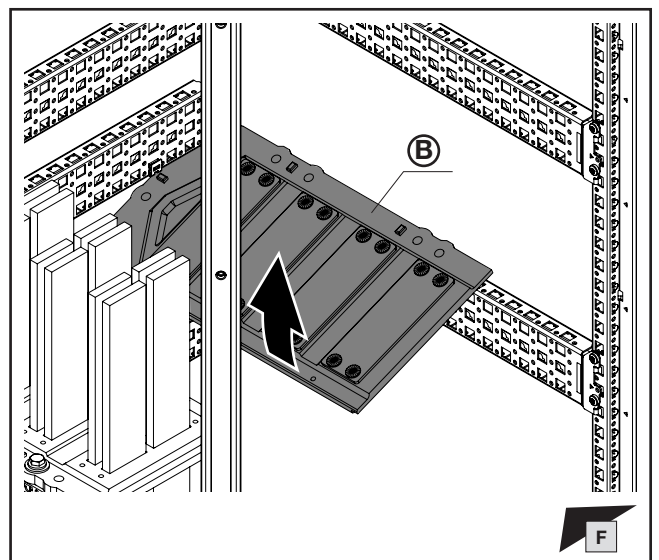
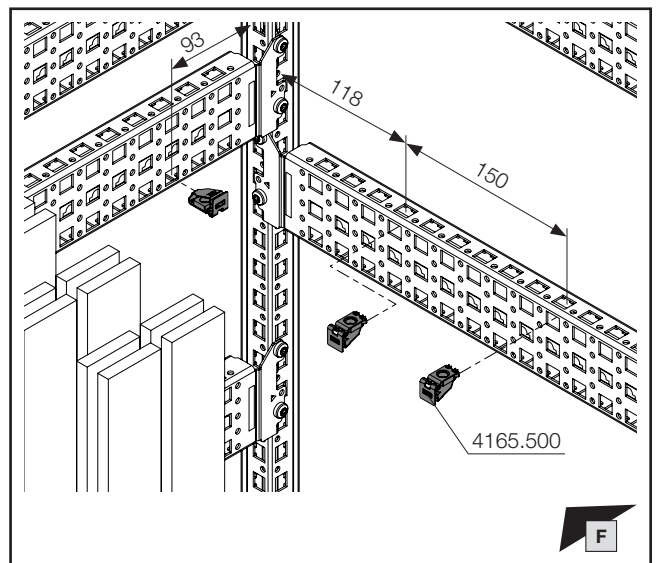
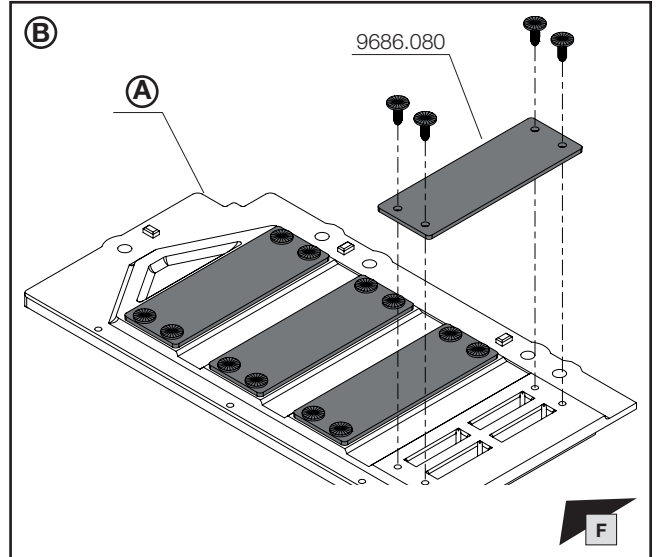
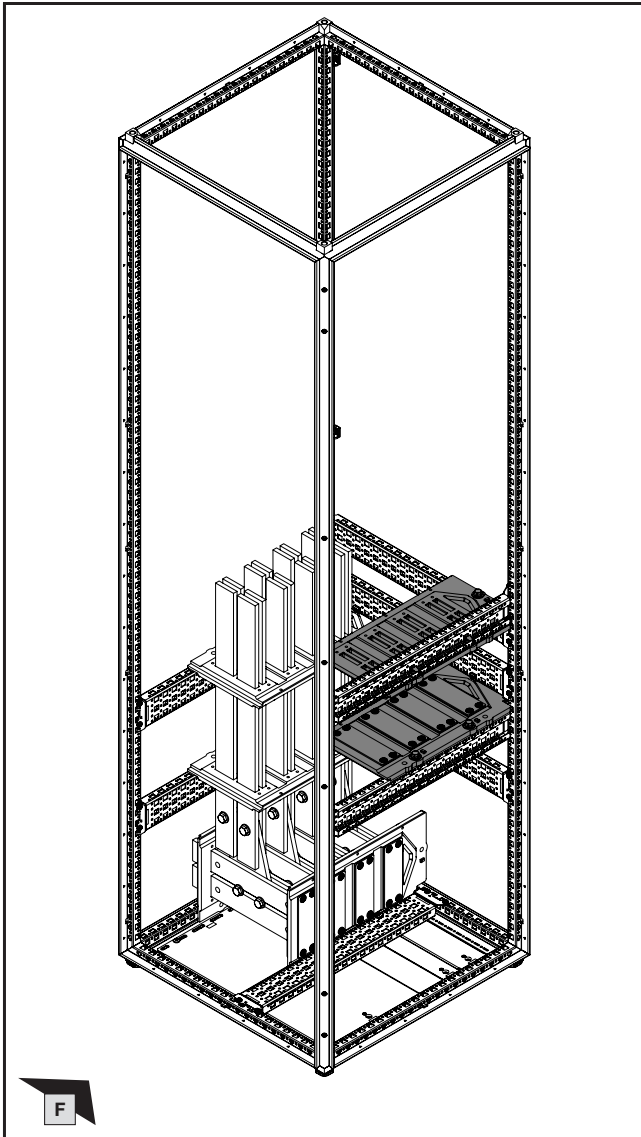

Sammelschiene Abmessung mm Busbar dimension mm Dimensions de la barre mm	Anreihung Baying Juxtaposition	(A) Best.-Nr. Model No. Référence
30 x 10	×	9686.010
50 x 10	×	9686.040

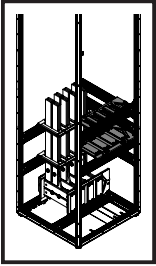

- 1. Montage Hochführungsfeld – Einbaulage Boden auf Dach
- 1. Fitting the riser section – Mounting position: Base section to roof
- 1. Zone de montage vertical – position base vers toit

- 1.9 Montage mittlere Sammelschienenhalter vertikal
- 1.9 Fitting the middle busbar holder, vertical
- 1.9 Montage des supports centraux de jeux de barres verticaux

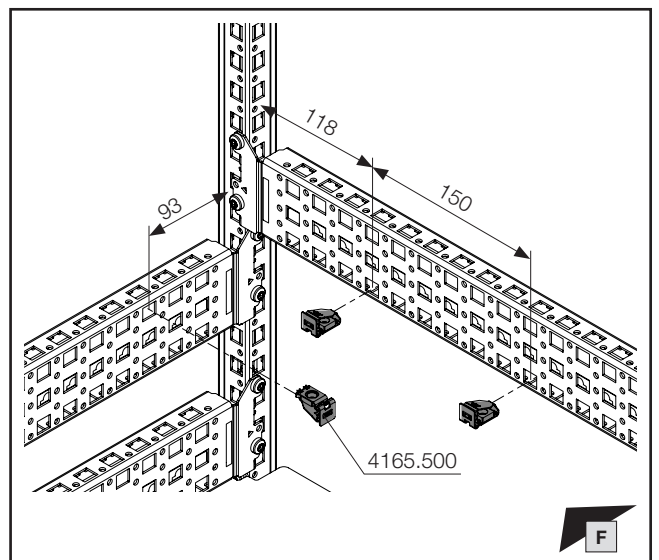
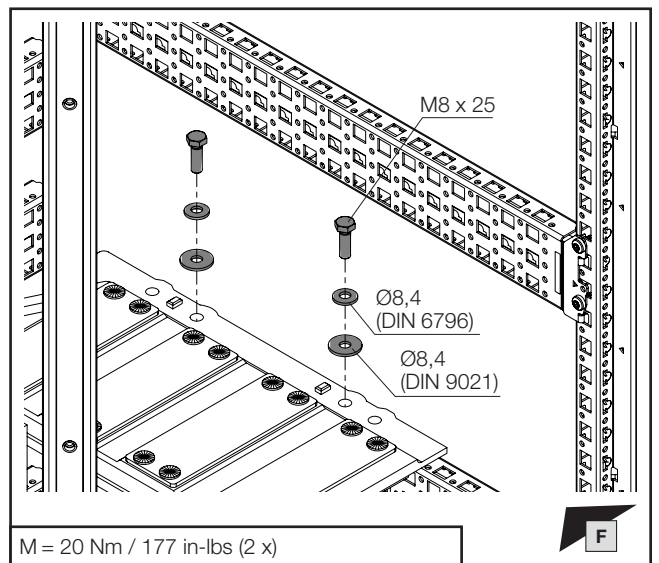
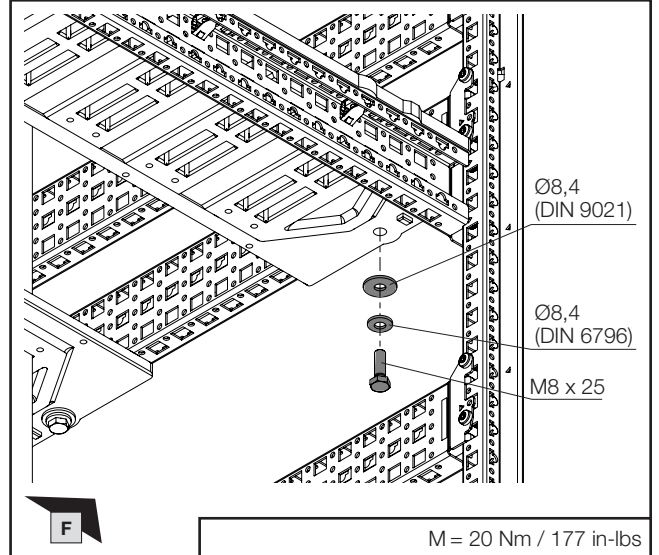
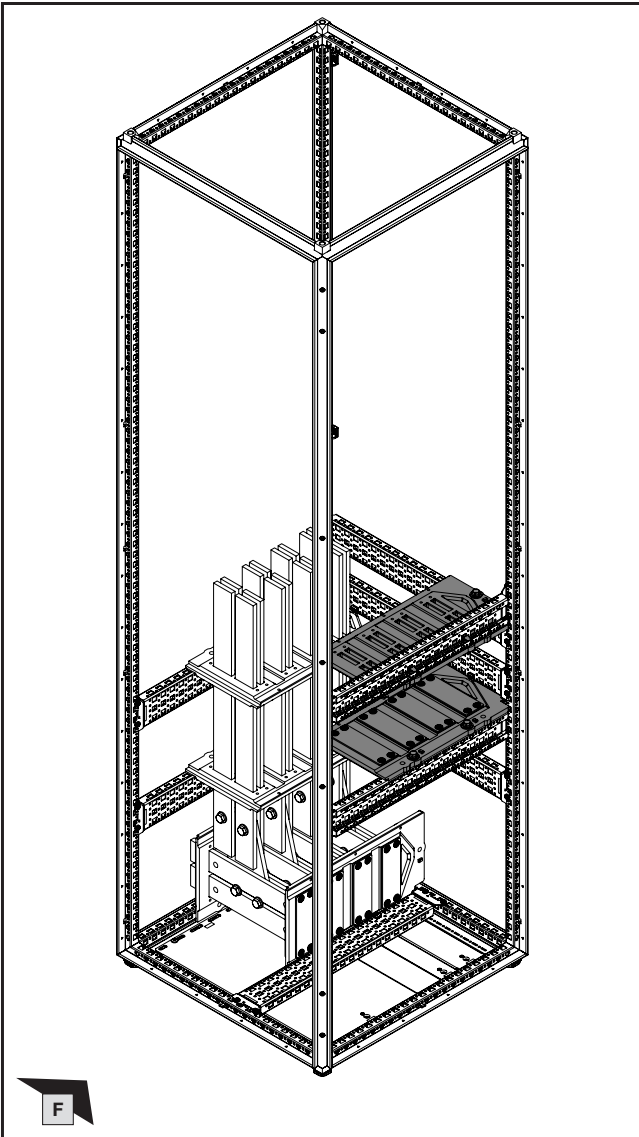

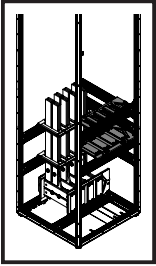

SW13



DE EN FR



- 1. Montage Hochführungsfeld – Einbaulage Boden auf Dach
- 1. Fitting the riser section – Mounting position: Base section to roof
- 1. Zone de montage vertical – position base vers toit

- 1.9 Montage mittlere Sammelschienenhalter vertikal
- 1.9 Fitting the middle busbar holder, vertical
- 1.9 Montage des supports centraux de jeux de barres verticaux

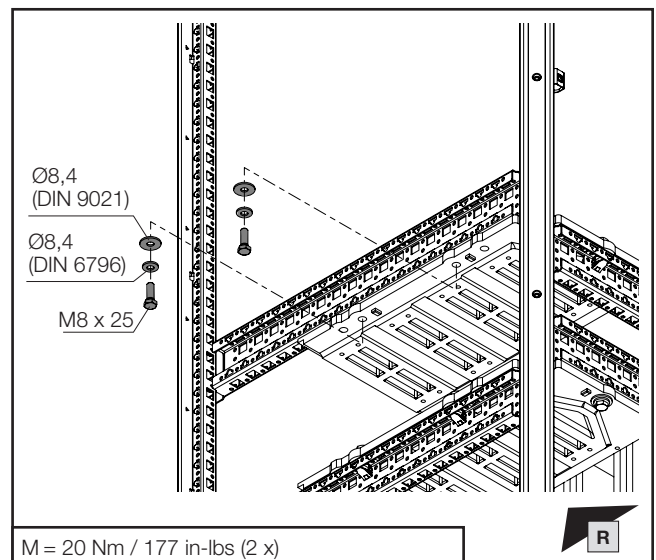
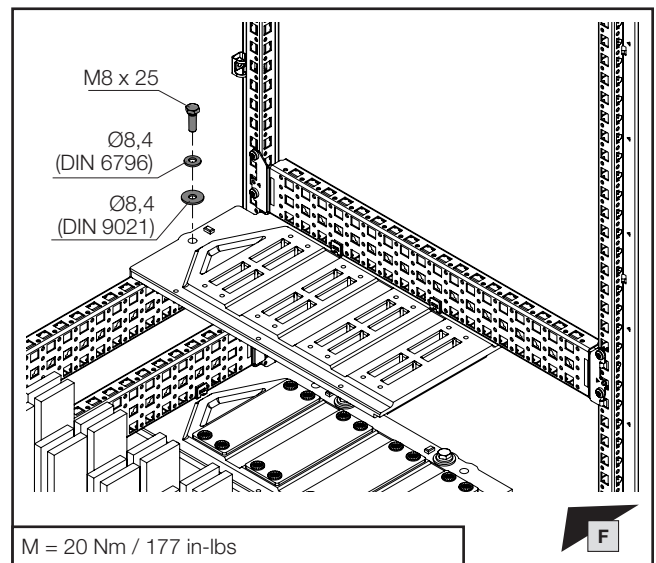
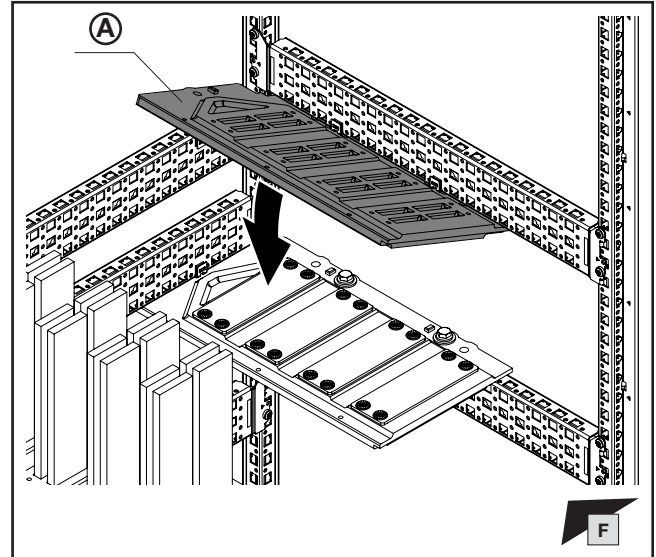
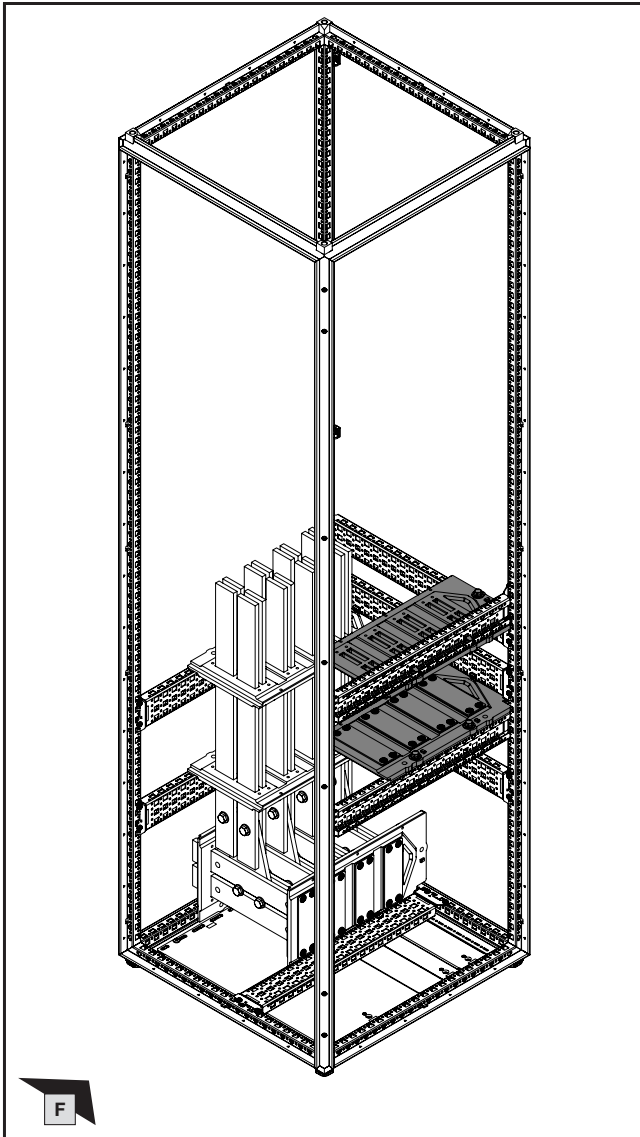

Sammelschiene Abmessung mm Busbar dimension mm Dimensions de la barre mm	Anreihung Baying Juxtaposition	Ⓐ Best.-Nr. Model No. Référence
30 x 10	×	9686.010
50 x 10	×	9686.040

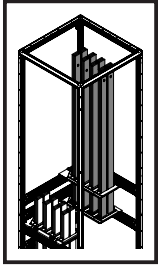

1. Montage Hochführungsfeld – Einbaulage Boden auf Dach
1. Fitting the riser section – Mounting position: Base section to roof
1. Zone de montage vertical – position base vers toit

- 1.10 Einbringung obere vertikale Verteilsammelschienen
- 1.10 Incorporating the upper vertical distribution busbars
- 1.10 Introduction des jeux de barres de distribution verticaux supérieurs

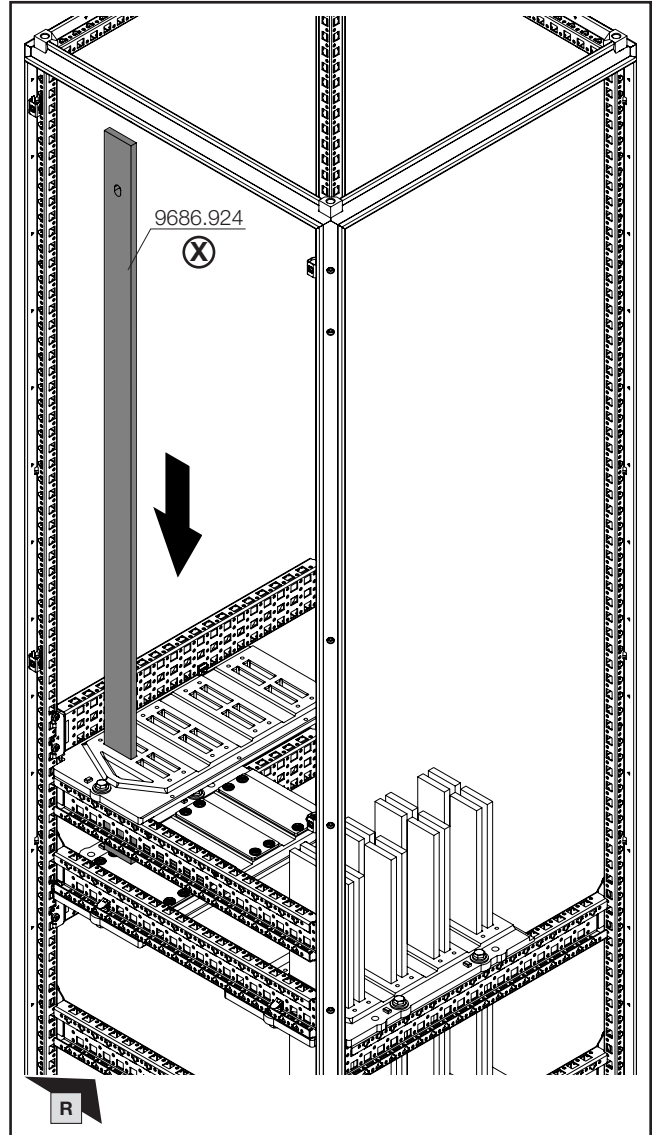
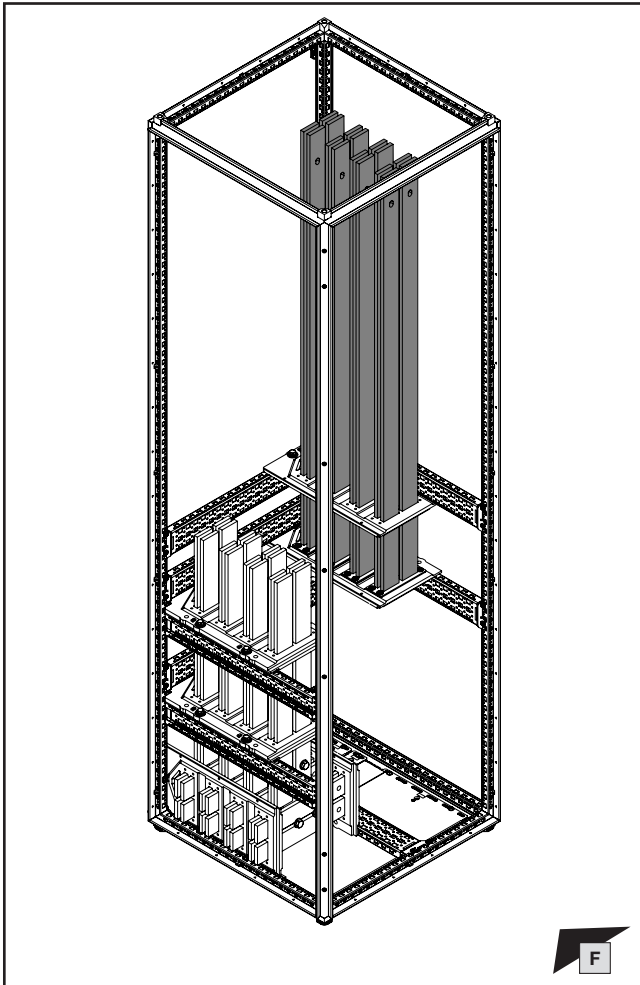

Hinweis / Note / Remarque (X)

Die Länge der Sammelschienen wird mit Hilfe der Online-Berechnungssoftware „RiPower“ im Niederspannungsschaltanlagen Konfigurator ermittelt.

The length of the busbars is determined using the online calculation software "RiPower" in the low-voltage switchgear configurator.

La longueur des jeux de barres est déterminée à l'aide du logiciel de calcul en ligne « RiPower » du configurateur de TGBT.



RiPower

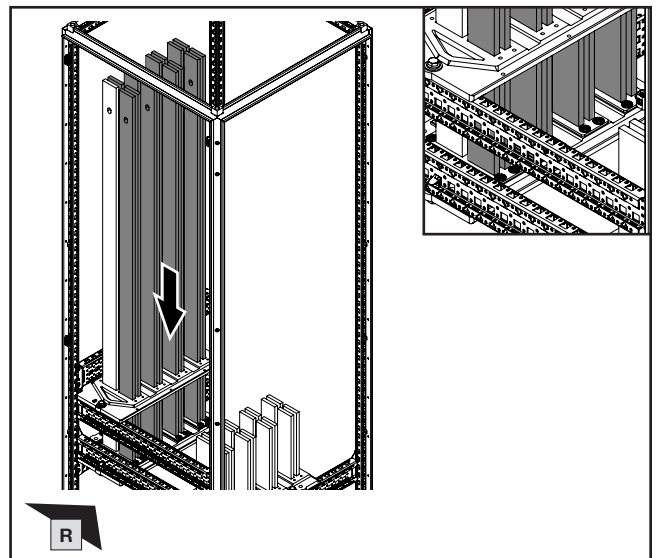

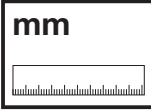
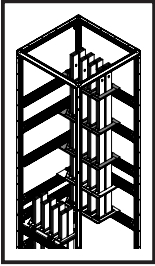

1. Montage Hochführungsfeld – Einbaulage Boden auf Dach
 1. Fitting the riser section – Mounting position: Base section to roof
 1. Zone de montage vertical – position base vers toit

- 1.11 Montage obere System-Chassis und Sammelschienenhalter
 1.11 Fitting the upper punched sections with mounting flanges and busbar supports
 1.11 Montage des rails de montage supérieurs et des supports de jeux de barres

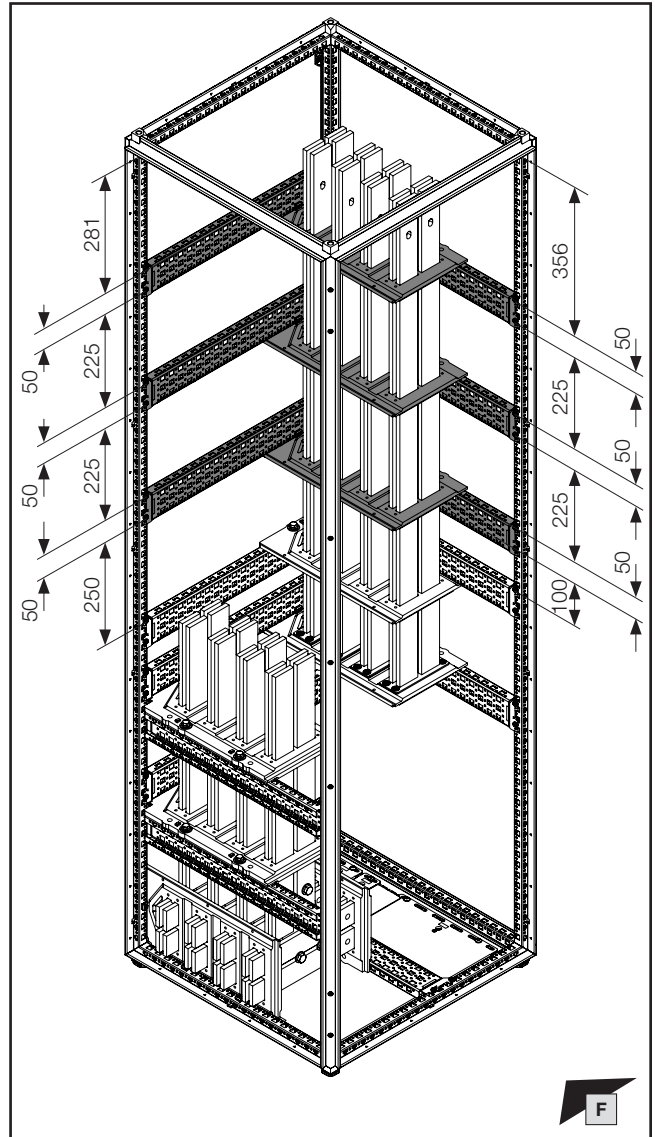
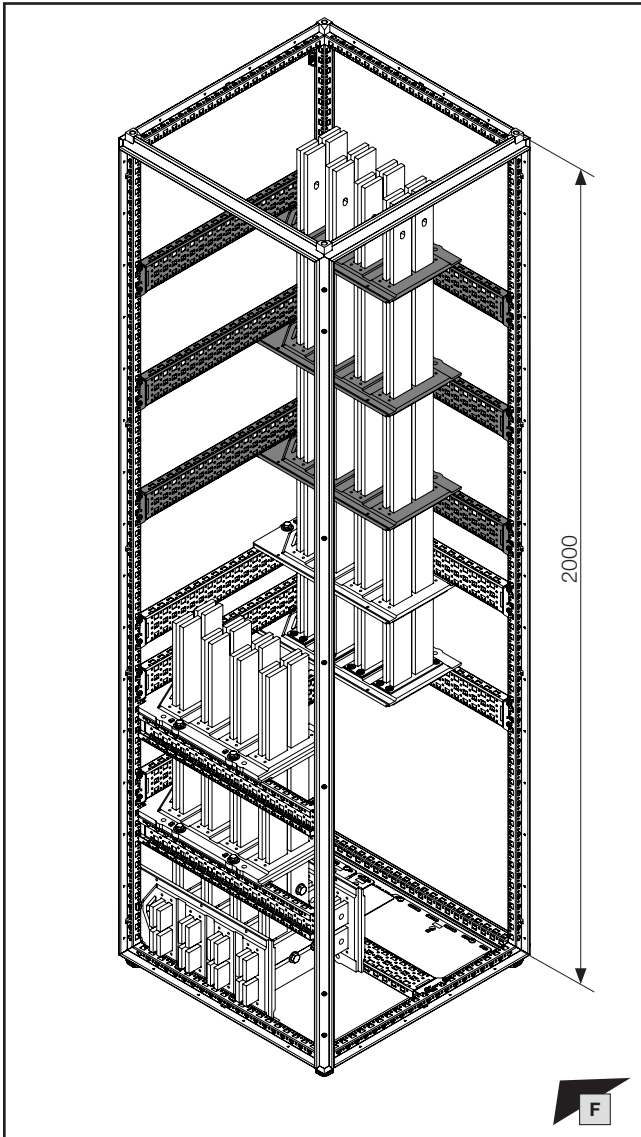

Hinweis / Note / Remarque

Bei erschwelter Montage Befestigungsschrauben der Sammelschienenhalter lösen und zum Abschluss des Montageschritts anziehen.

If fitting is difficult, loosen the assembly screws of the busbar supports and tighten them at the end of this step.

En cas de difficulté de montage, desserrer les vis de fixation des supports de jeux de barres et les resserrer en fin de montage.



Hinweis / Note / Remarque

Die Reihenfolge der Montage auf den nächsten drei Seiten ist schrittweise zu befolgen.

The assembly sequence on the next three pages must be followed step by step.

L'ordre de montage sur les trois prochaines pages doit être respecté étape par étape.



Hinweis / Note / Remarque

Besonderheit Schrankhöhe 2200 mm: siehe Kapitel 2.5

Special feature with enclosure height 2200 mm: See chapter 2.5

Particularité pour la hauteur d'armoire 2200 mm : voir chapitre 2.5

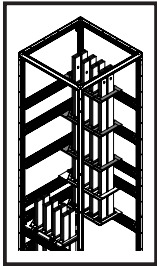

DE EN FR



1. Montage Hochführungsfeld – Einbaulage Boden auf Dach
1. Fitting the riser section – Mounting position: Base section to roof
1. Zone de montage vertical – position base vers toit

- 1.11 Montage obere System-Chassis und Sammelschienehalter
- 1.11 Fitting the upper punched sections with mounting flanges and busbar supports
- 1.11 Montage des rails de montage supérieurs et des supports de jeux de barres

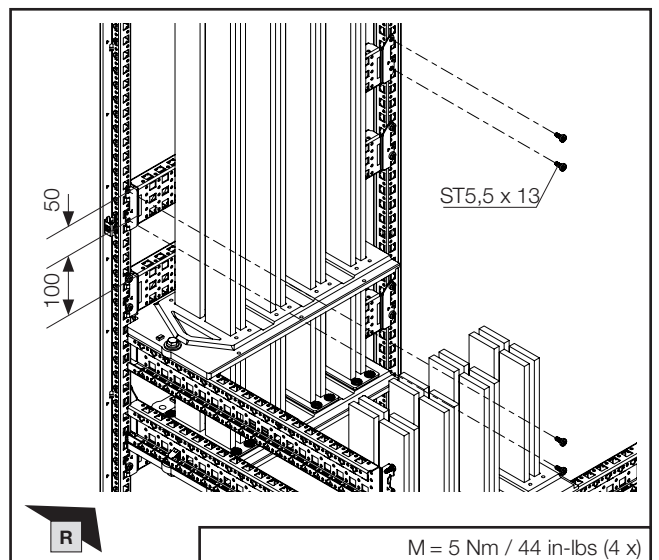
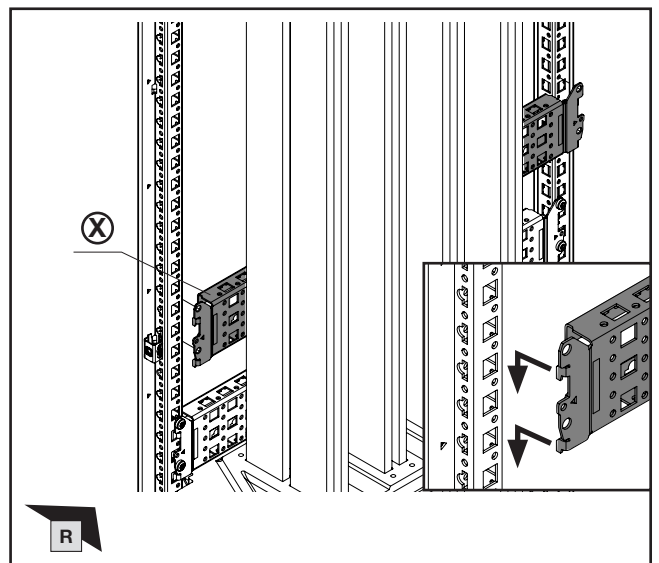
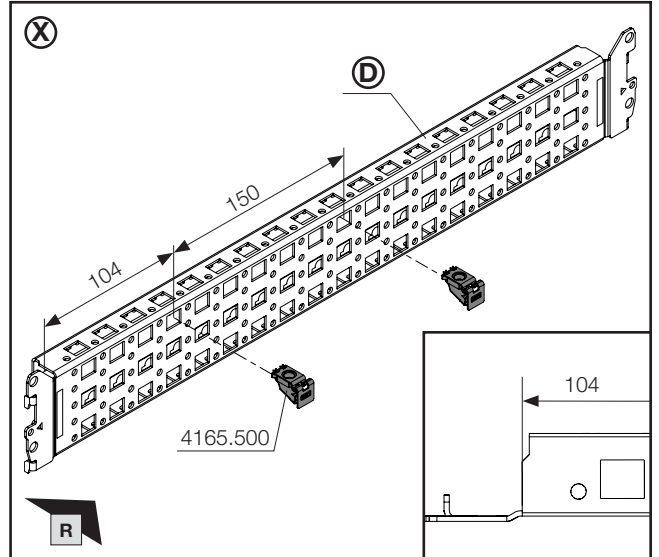
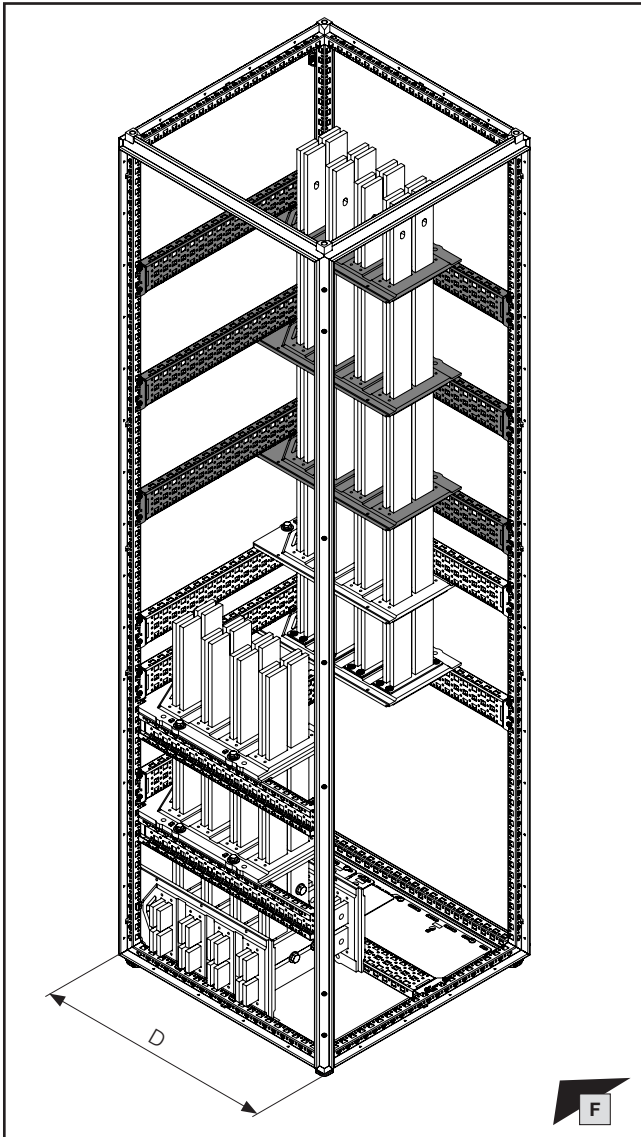

D mm	Best.-Nr. Model No. Référence
600	8617.130
800	8617.140

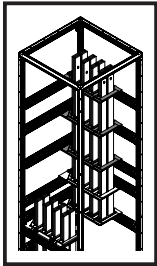

DE EN FR



1. Montage Hochführungsfeld – Einbaulage Boden auf Dach
 1. Fitting the riser section – Mounting position: Base section to roof
 1. Zone de montage vertical – position base vers toit

- 1.11 Montage obere System-Chassis und Sammelschienehalter
 1.11 Fitting the upper punched sections with mounting flanges and busbar supports
 1.11 Montage des rails de montage supérieurs et des supports de jeux de barres

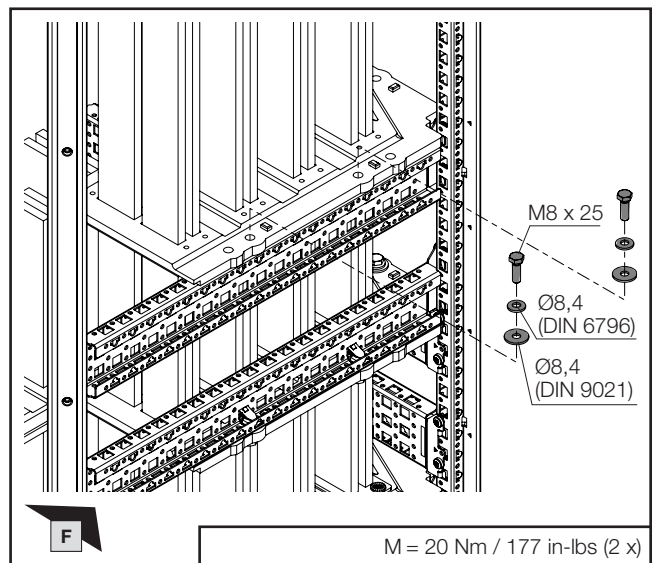
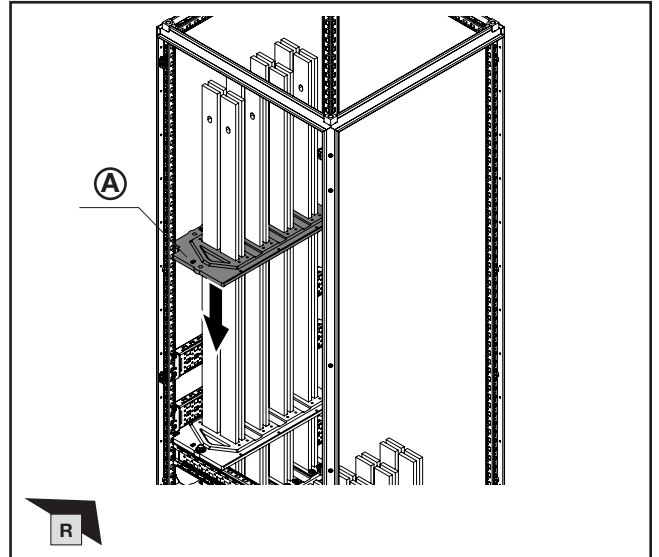
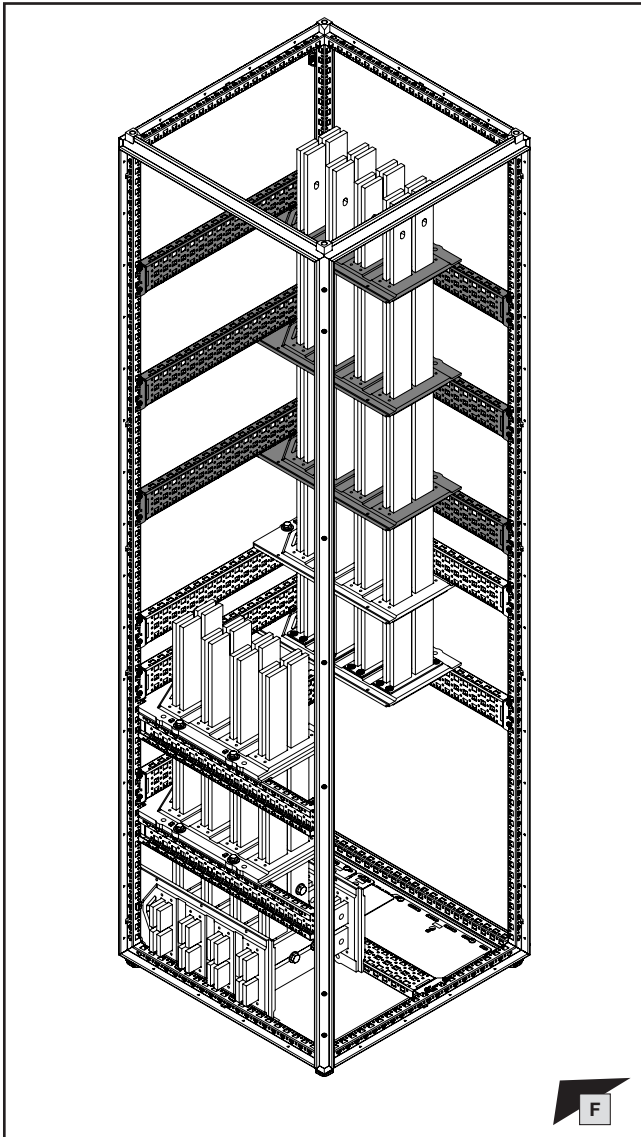

M = 20 Nm / 177 in-lbs (2 x)

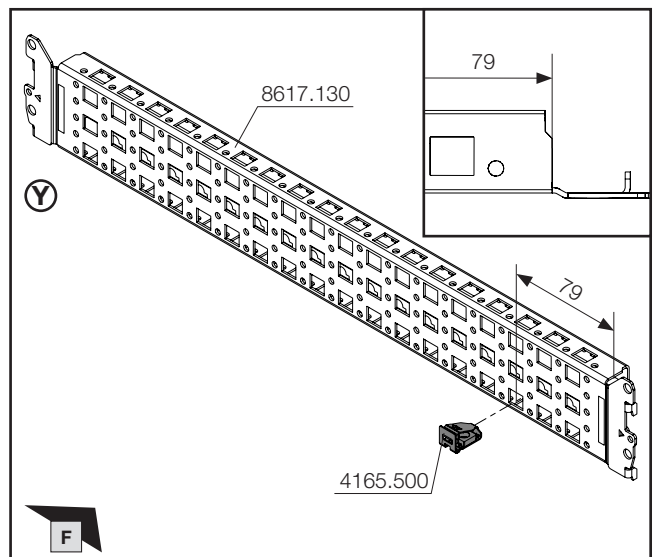

Sammelschiene Abmessung mm Busbar dimension mm Dimensions de la barre mm	Anreihung Baying Juxtaposition	A Best.-Nr. Model No. Référence
30 x 10	×	9686.010
50 x 10	×	9686.040

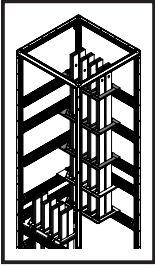

1. Montage Hochführungsfeld – Einbaulage Boden auf Dach
1. Fitting the riser section – Mounting position: Base section to roof
1. Zone de montage vertical – position base vers toit

- 1.11 Montage obere System-Chassis und Sammelschienehalter
- 1.11 Fitting the upper punched sections with mounting flanges and busbar supports
- 1.11 Montage des rails de montage supérieurs et des supports de jeux de barres

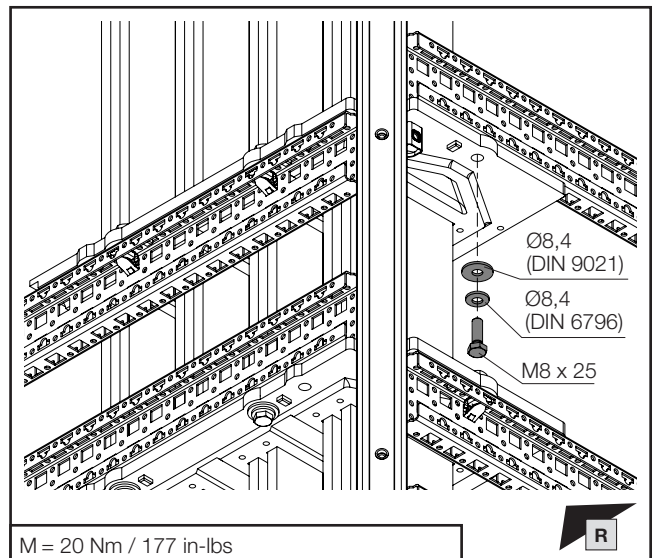
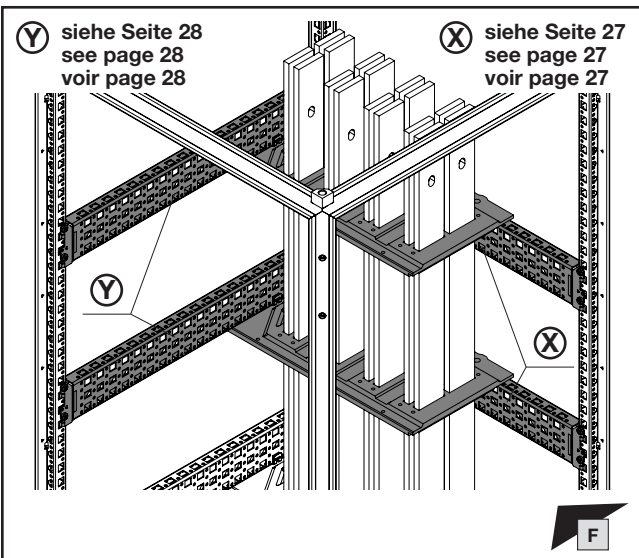
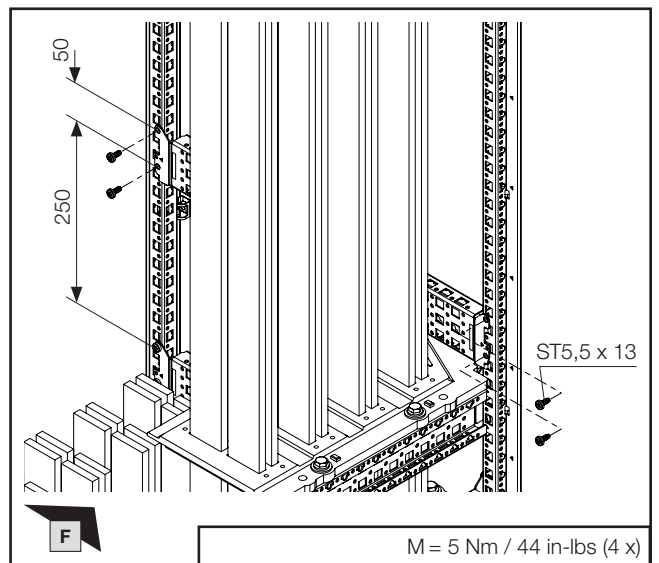
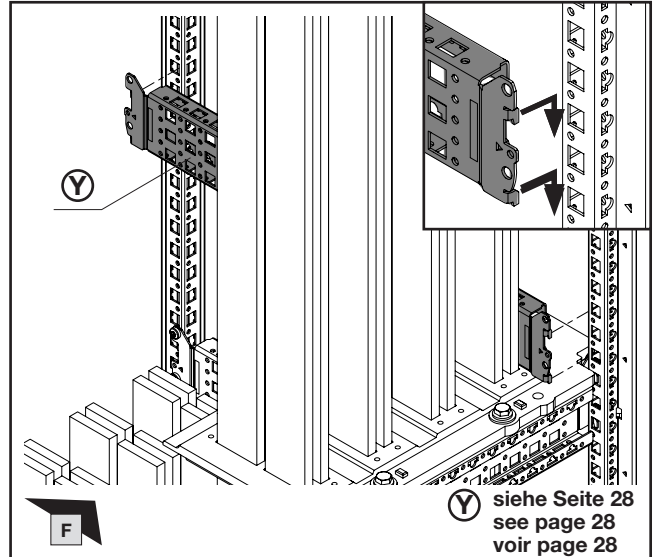
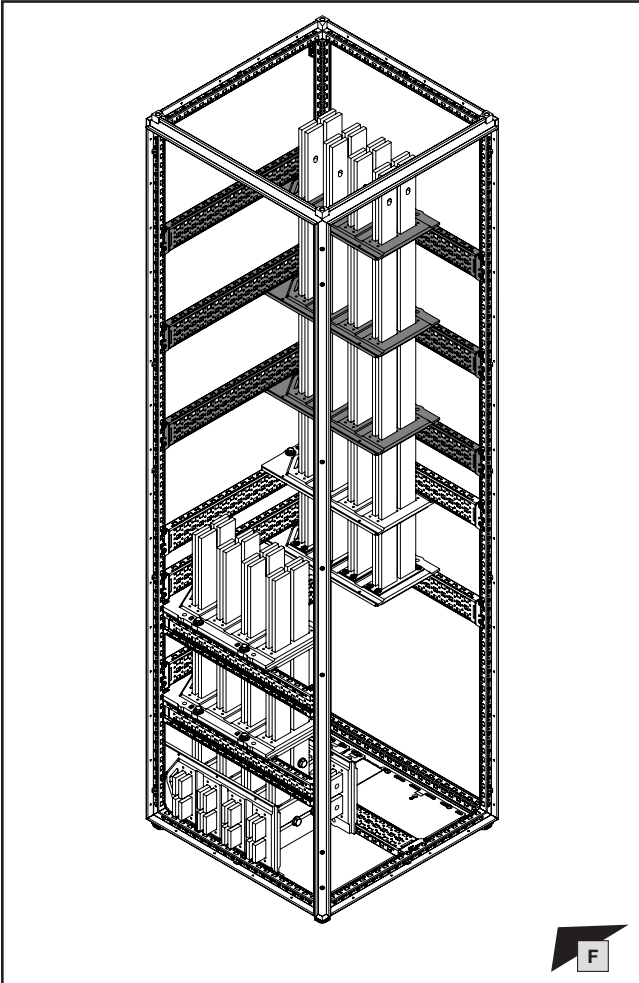

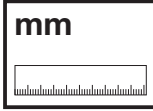
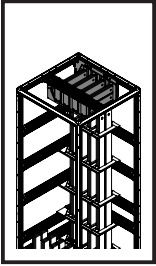

DE EN FR



- 1. Montage Hochführungsfeld – Einbaulage Boden auf Dach
- 1. Fitting the riser section – Mounting position: Base section to roof
- 1. Zone de montage vertical – position base vers toit

- 1.12 Montage des oberen Hauptschienensystems
- 1.12 Fitting the upper main busbar system
- 1.12 Montage des jeux de barres principaux supérieurs

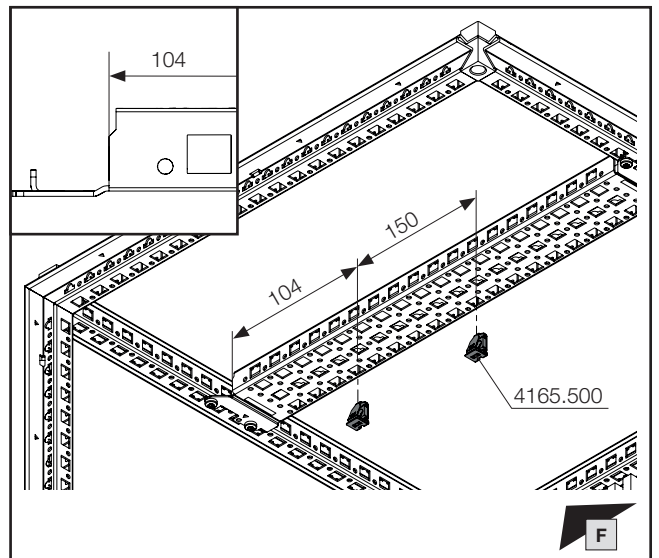
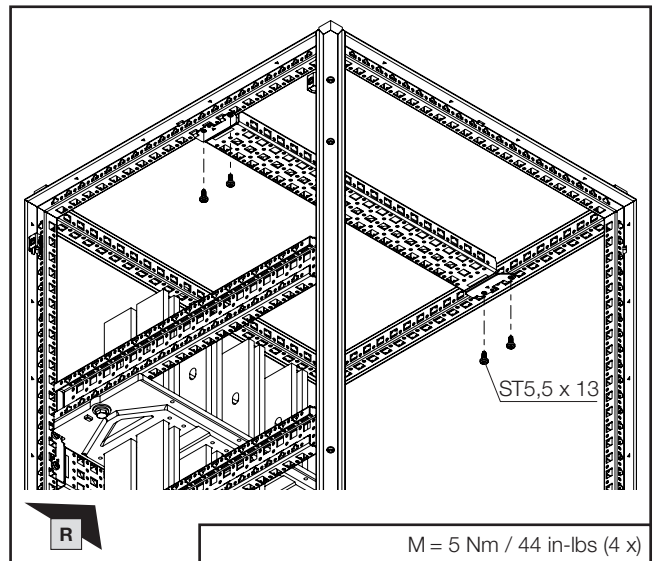
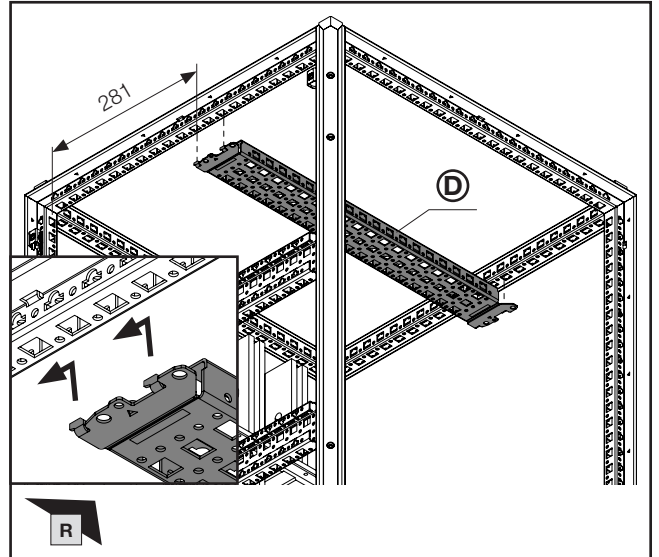
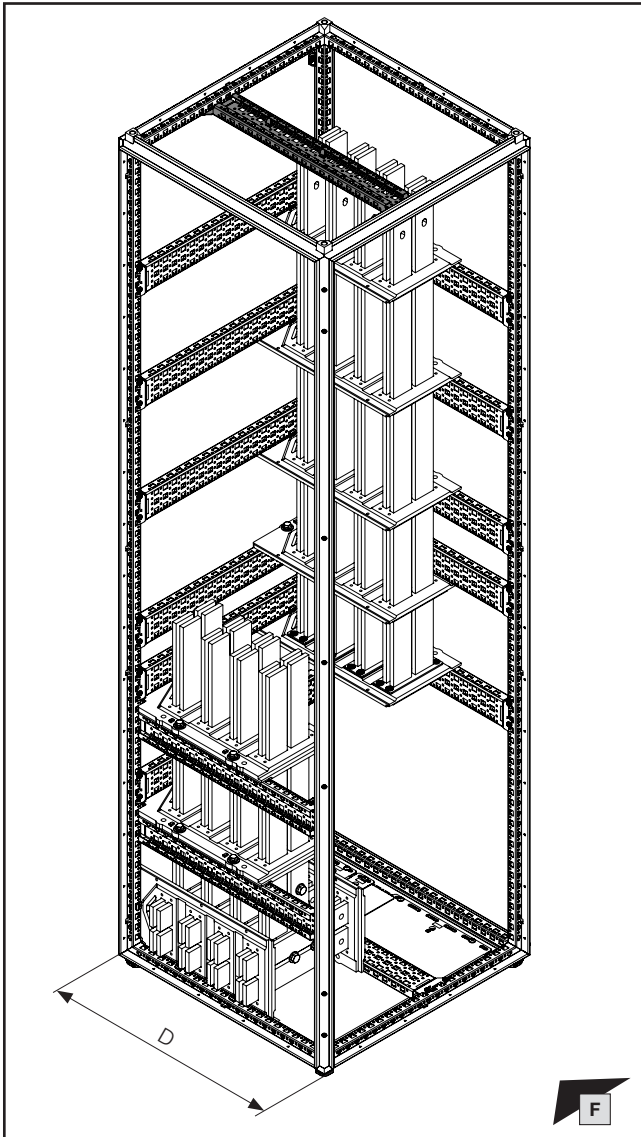

D mm	Best.-Nr. Model No. Référence
600	8617.130
800	8617.140

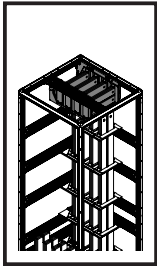

DE EN FR



1. Montage Hochführungsfeld – Einbaulage Boden auf Dach
1. Fitting the riser section – Mounting position: Base section to roof
1. Zone de montage vertical – position base vers toit

- 1.12 Montage des oberen Hauptschienensystems
- 1.12 Fitting the upper main busbar system
- 1.12 Montage des jeux de barres principaux supérieurs

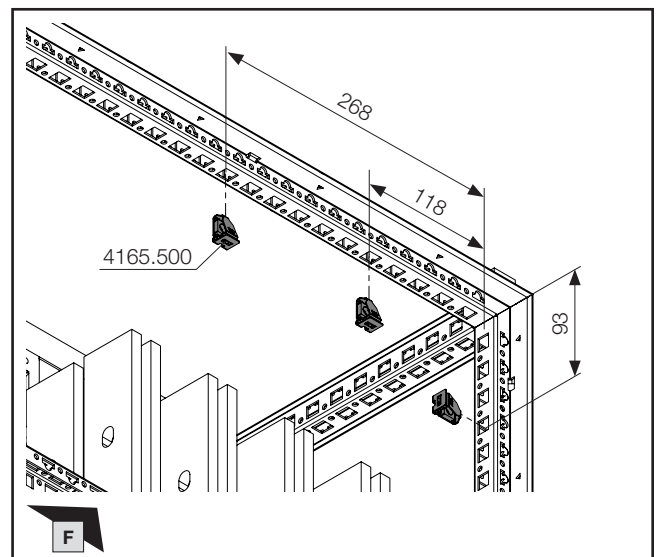
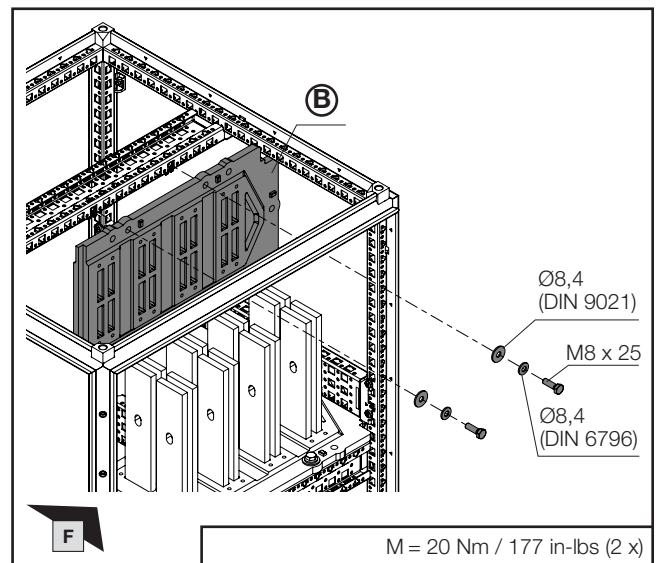
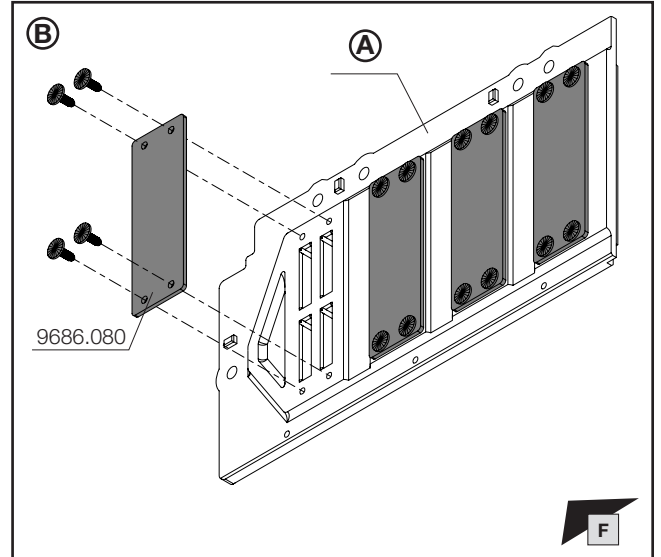
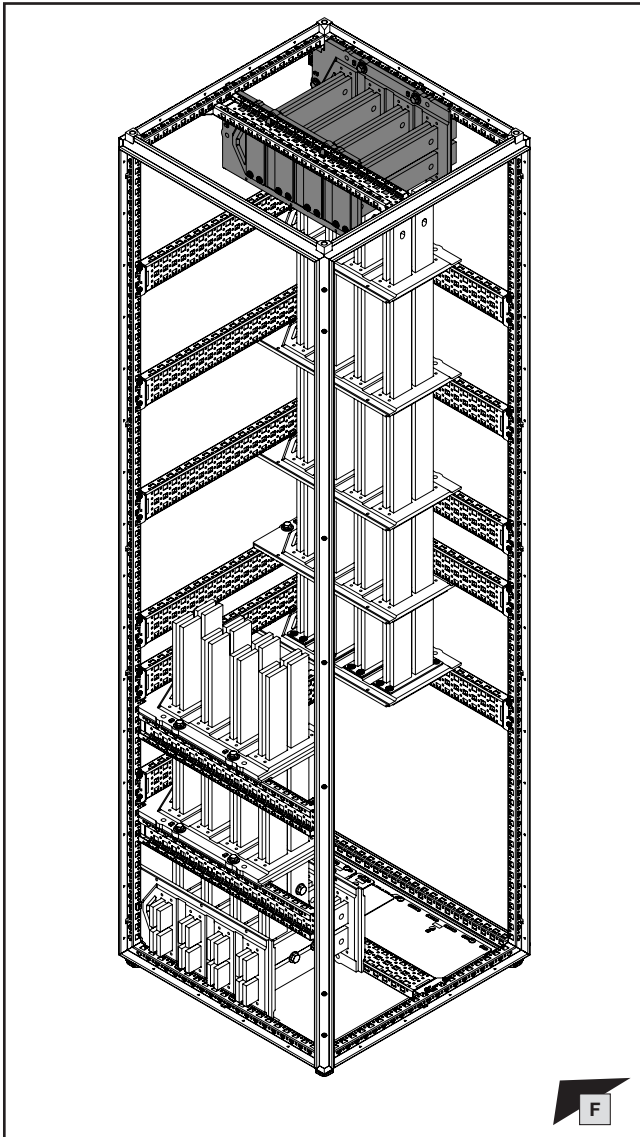

Sammelschiene Abmessung mm Busbar dimension mm Dimensions de la barre mm	Anreihung Baying Juxtaposition	(A) Best.-Nr. Model No. Référence
30 x 10	×	9686.010
50 x 10	×	9686.040

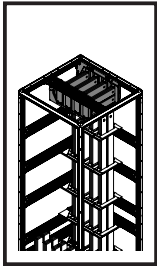

DE EN FR



1. Montage Hochführungsfeld – Einbaulage Boden auf Dach
1. Fitting the riser section – Mounting position: Base section to roof
1. Zone de montage vertical – position base vers toit

- 1.12 Montage des oberen Hauptschienensystems
- 1.12 Fitting the upper main busbar system
- 1.12 Montage des jeux de barres principaux supérieurs

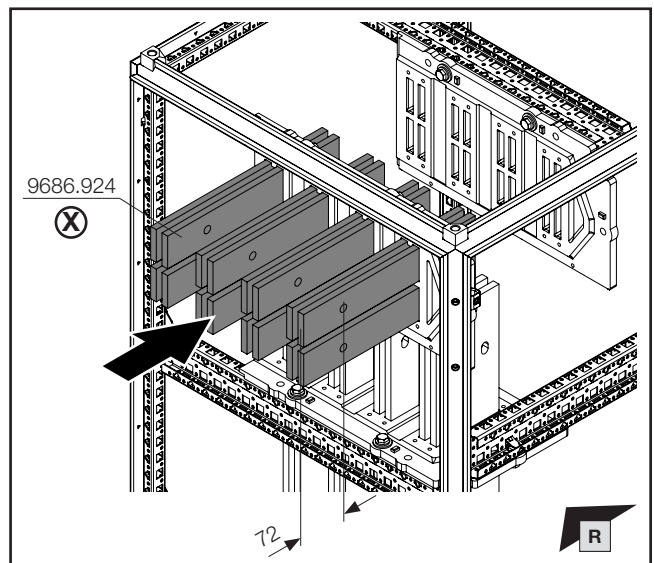
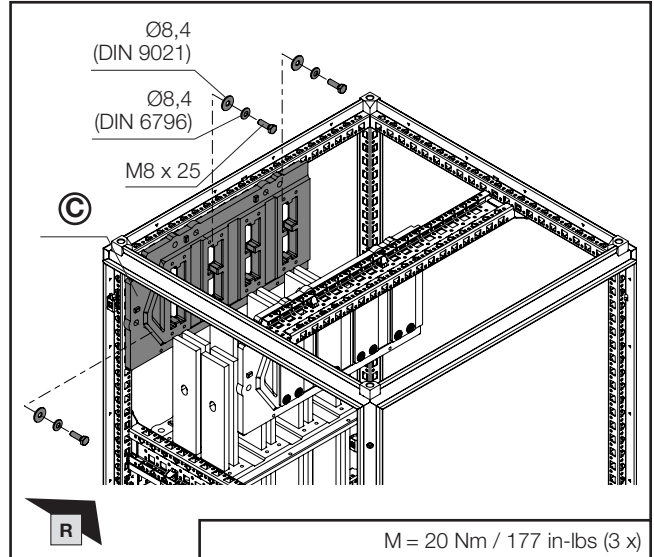
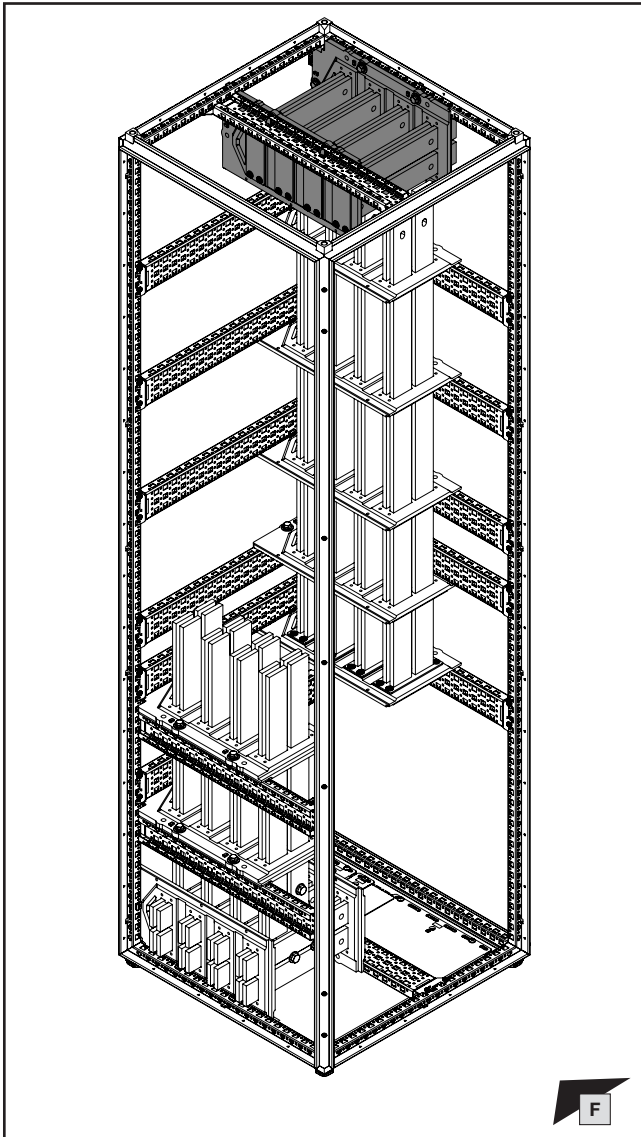

Hinweis / Note / Remarque (X)

Die Länge der Sammelschienen wird mit Hilfe der Online-Berechnungssoftware „RiPower“ im Niederspannungsschaltanlagen Konfigurator ermittelt.

The length of the busbars is determined using the online calculation software "RiPower" in the low-voltage switchgear configurator.

La longueur des jeux de barres est déterminée à l'aide du logiciel de calcul en ligne « RiPower » du configurateur de TGBT.



RiPower

Sammelschiene Abmessung mm Busbar dimension mm Dimensions de la barre mm	Anreihung Baying Juxtaposition	© Best.-Nr. Model No. Référence
30 x 10	✓	9686.000
50 x 10	✓	9686.030

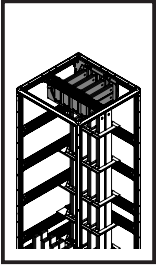

- 1. Montage Hochführungsfeld – Einbaulage Boden auf Dach
- 1. Fitting the riser section – Mounting position: Base section to roof
- 1. Zone de montage vertical – position base vers toit

- 1.12 Montage des oberen Hauptschienensystems
- 1.12 Fitting the upper main busbar system
- 1.12 Montage des jeux de barres principaux supérieurs

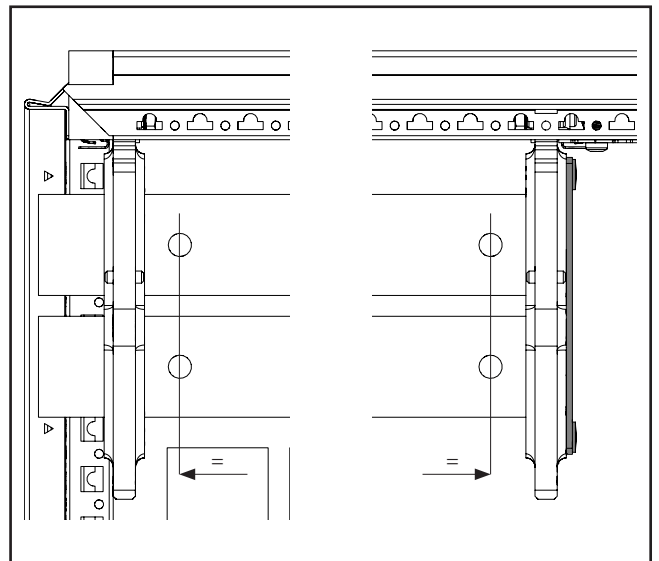
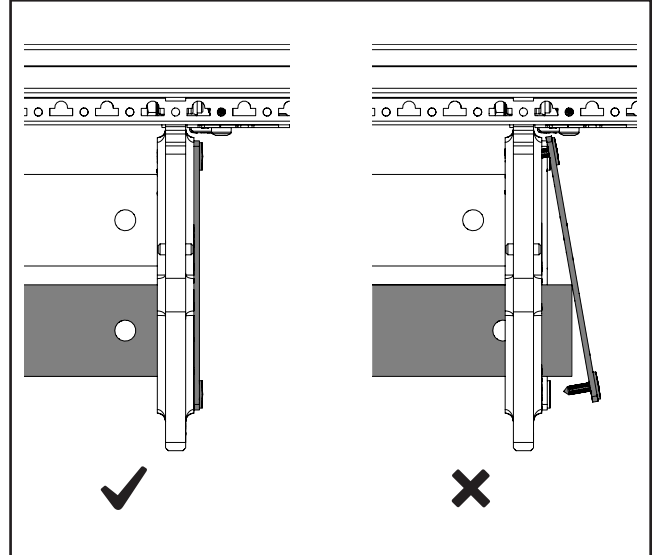
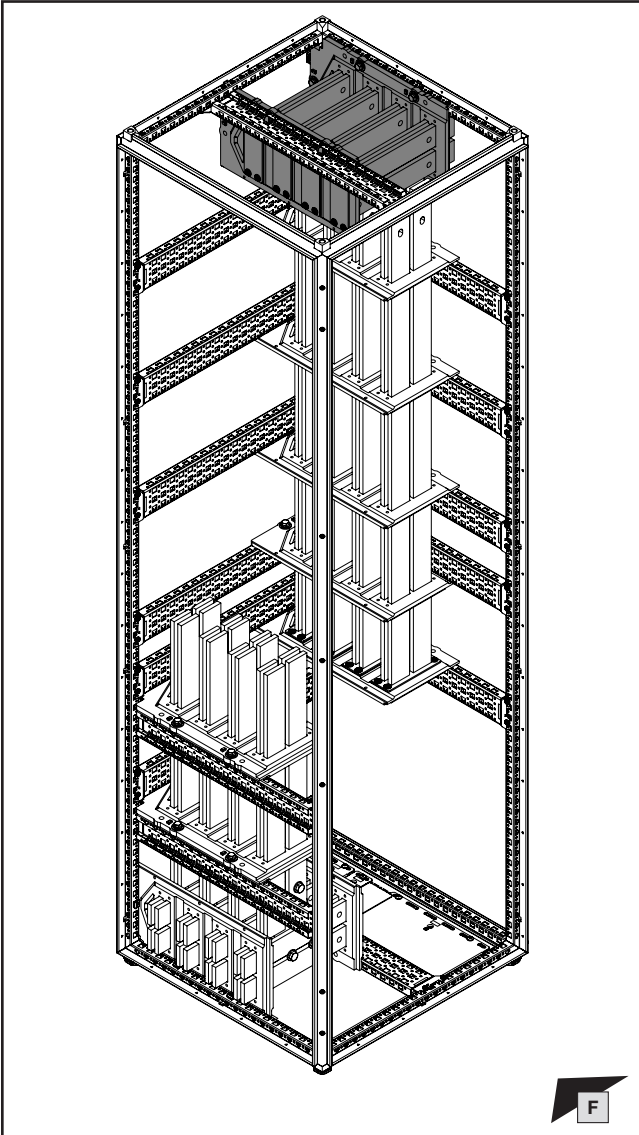

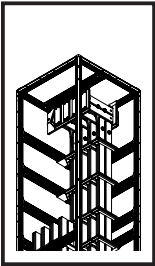

SW16/
SW17

DE EN FR



1. Montage Hochführungsfeld – Einbaulage Boden auf Dach
1. Fitting the riser section – Mounting position: Base section to roof
1. Zone de montage vertical – position base vers toit

1.13 Anbindung oberes vertikales Verteilsammelschienensystem

1.13 Connecting the upper vertical multi-terminal busbar system

1.13 Connexion des jeux de barres de distribution verticaux supérieurs

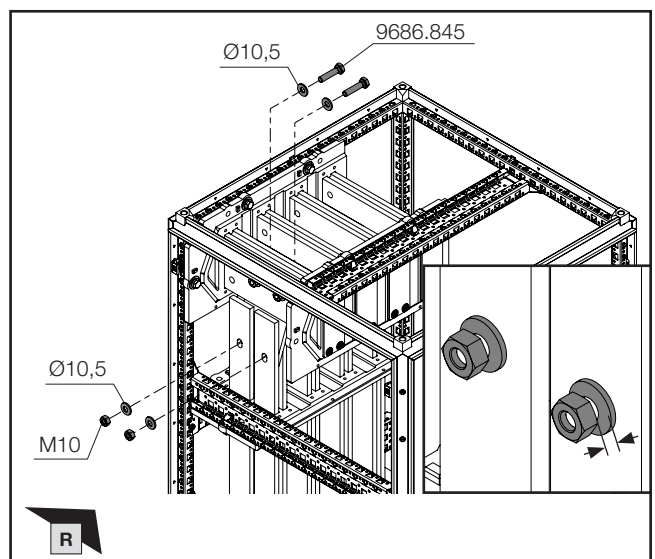
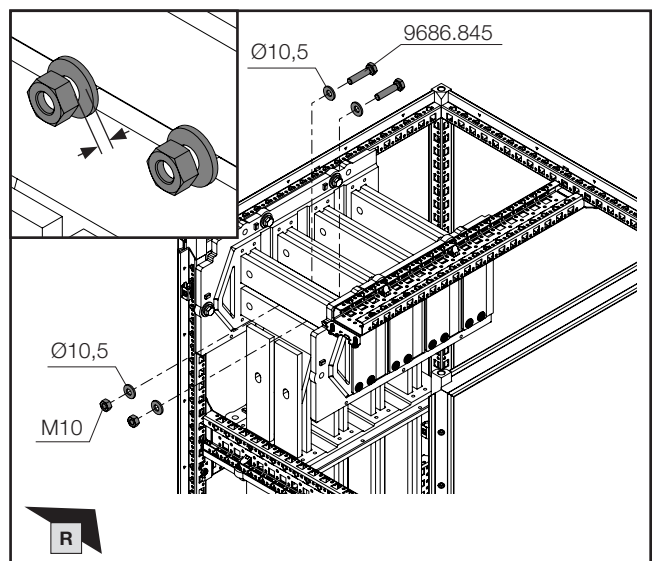
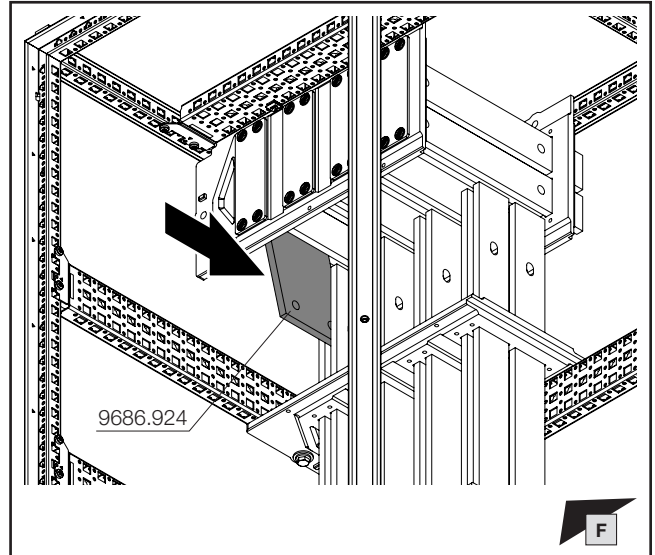
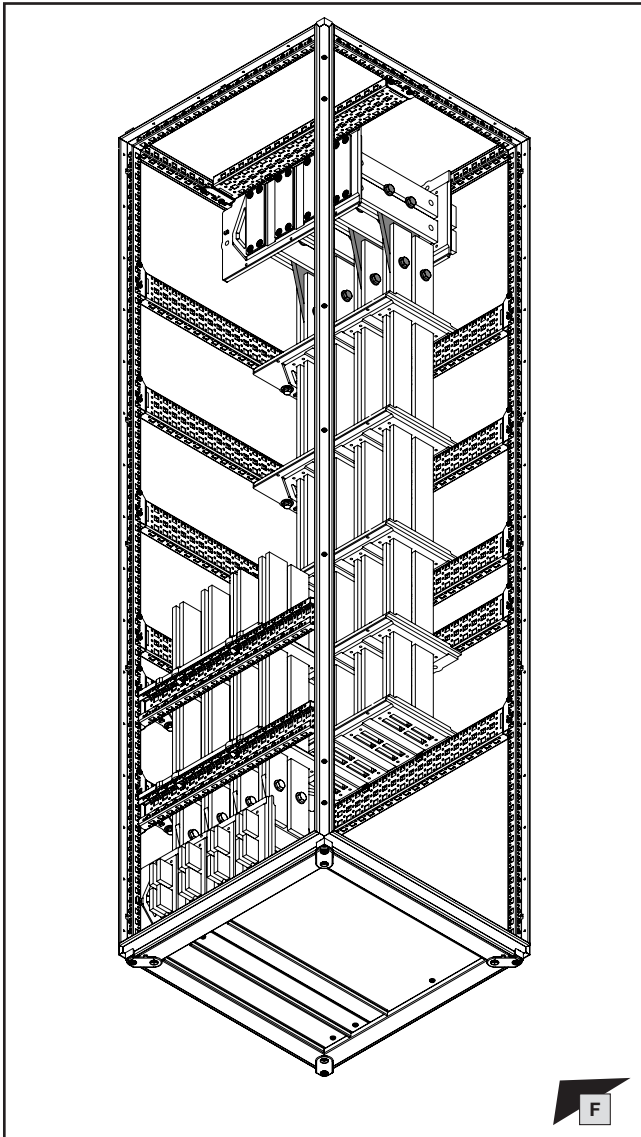

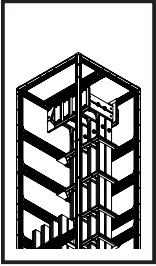

SW16/
SW17

DE EN FR



1. Montage Hochführungsfeld – Einbaulage Boden auf Dach
1. Fitting the riser section – Mounting position: Base section to roof
1. Zone de montage vertical – position base vers toit

- 1.13 Anbindung oberes vertikales Verteilsammelschienensystem
- 1.13 Connecting the upper vertical multi-terminal busbar system
- 1.13 Connexion des jeux de barres de distribution verticaux supérieurs

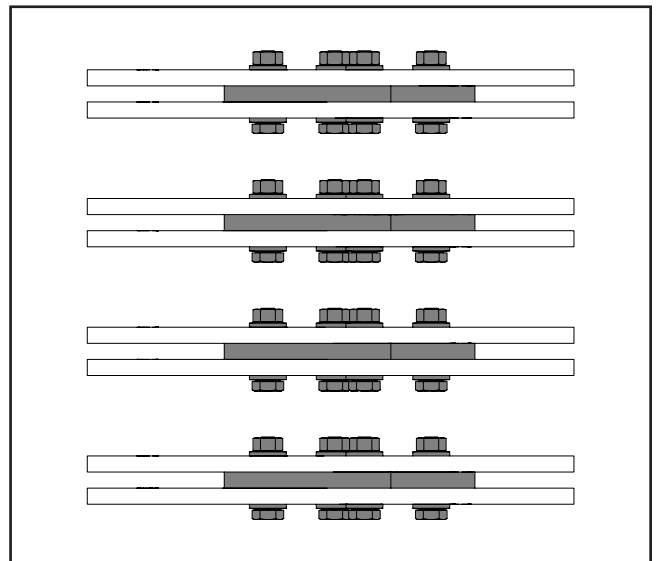
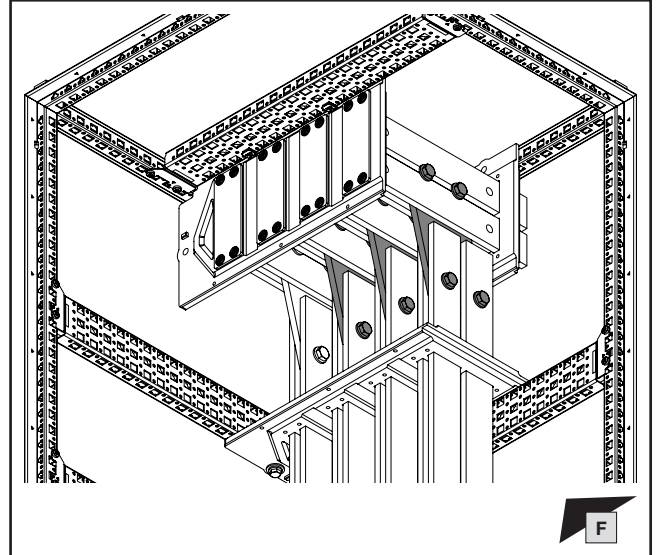
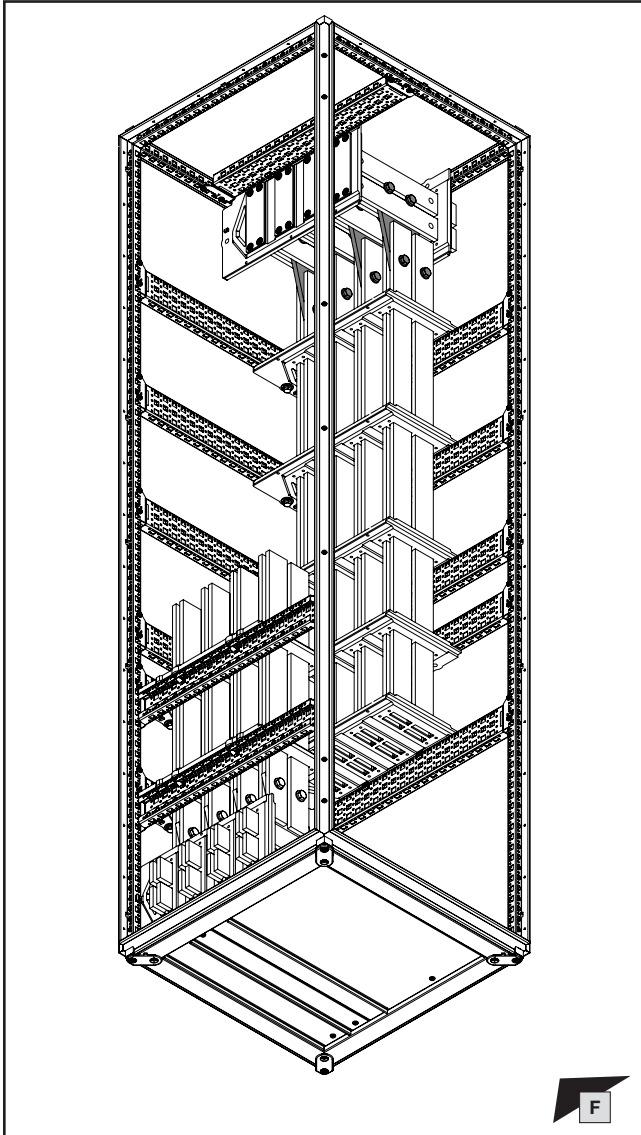

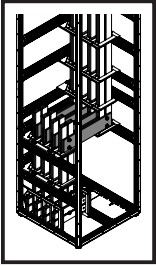

SW16/
SW17

DE EN FR



1. Montage Hochführungsfeld – Einbaulage Boden auf Dach
1. Fitting the riser section – Mounting position: Base section to roof
1. Zone de montage vertical – position base vers toit

1.14 Verbindung der vertikalen Verteilsammelschienensysteme

1.14 Connecting the vertical multi-terminal busbar systems

1.14 Raccordement des jeux de barres de distribution verticaux

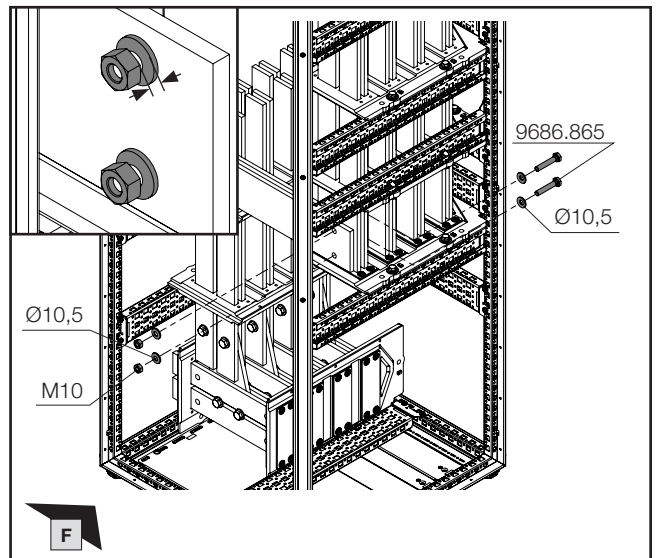
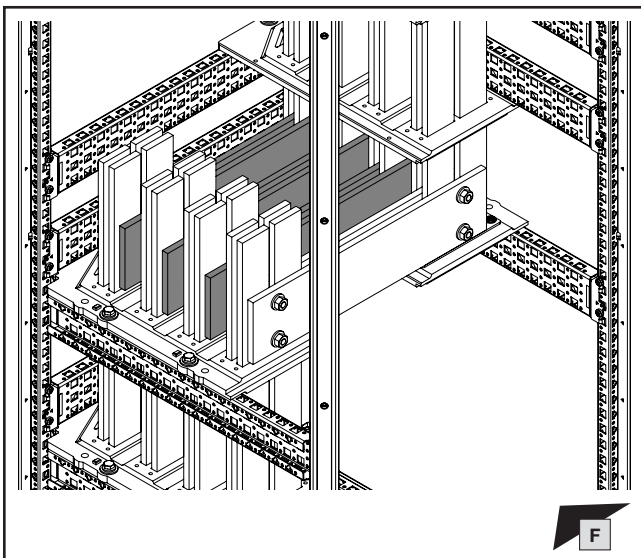
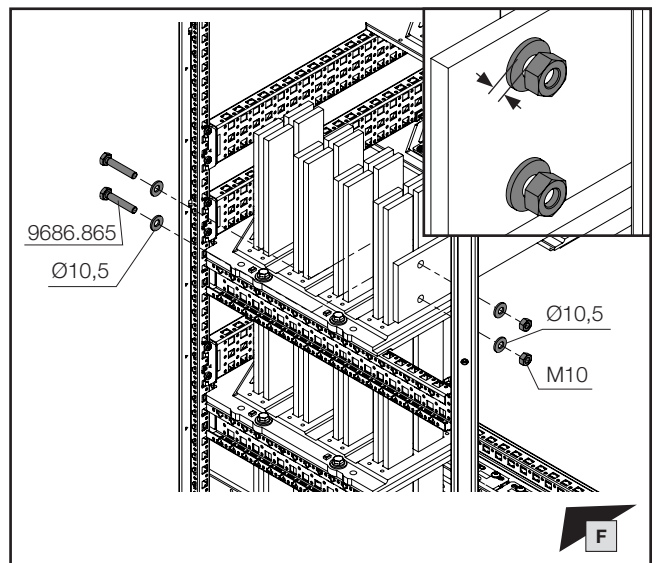
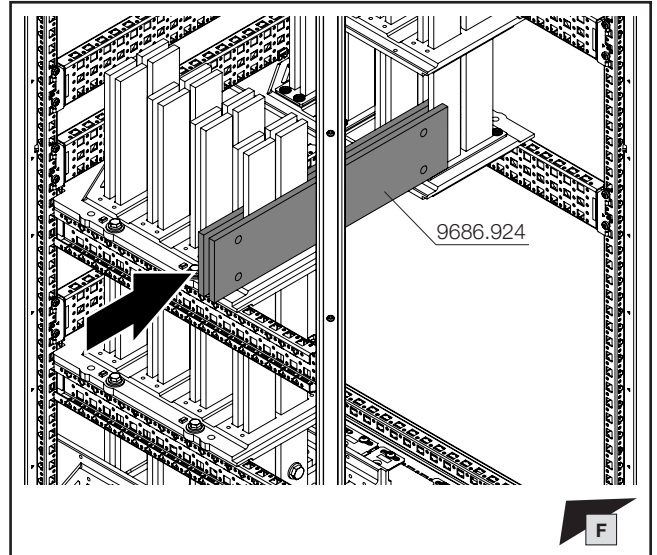
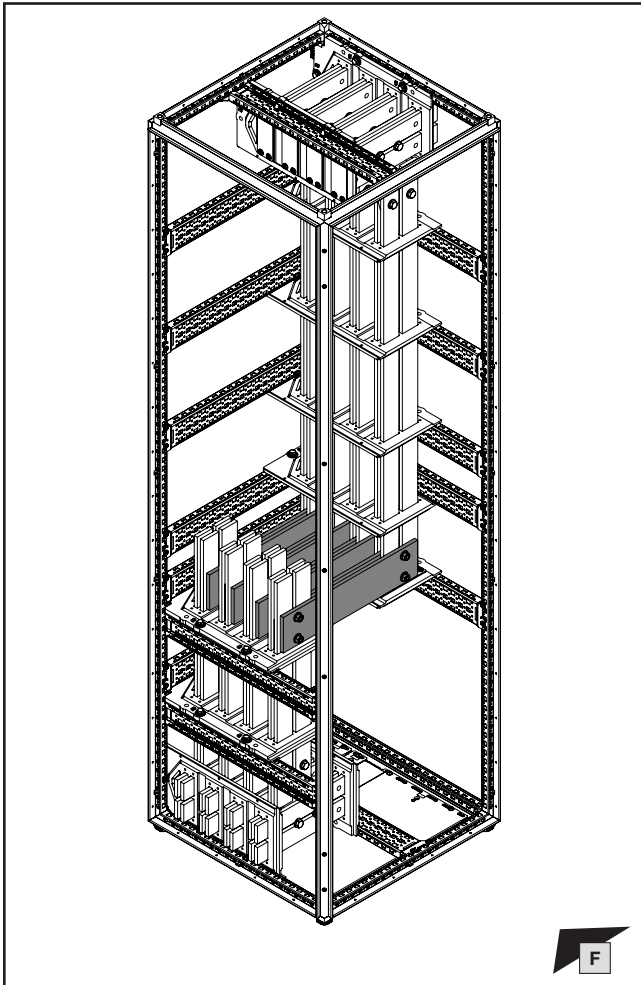

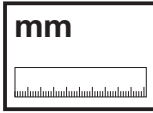
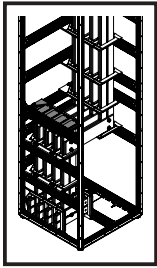

DE EN FR



1. Montage Hochführungsfeld – Einbaulage Boden auf Dach
1. Fitting the riser section – Mounting position: Base section to roof
1. Zone de montage vertical – position base vers toit

- 1.15 Montage System-Chassis und Sammelschienenhalter
- 1.15 Fitting the punched section with mounting flange and busbar support
- 1.15 Montage du rail de montage et des supports de jeux de barres

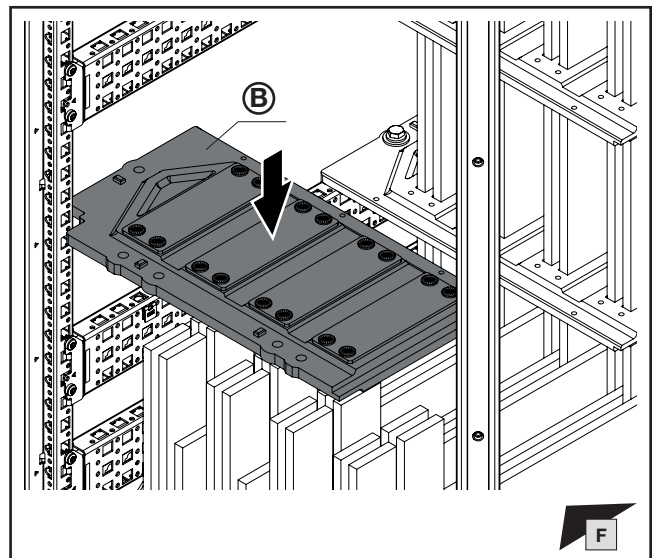
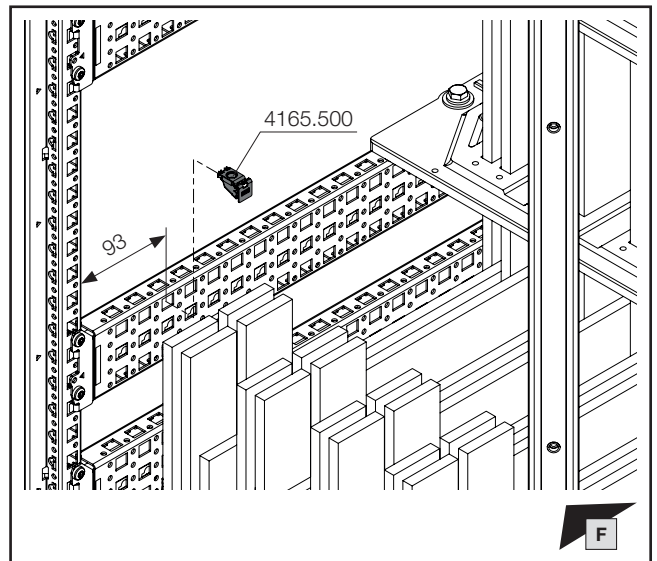
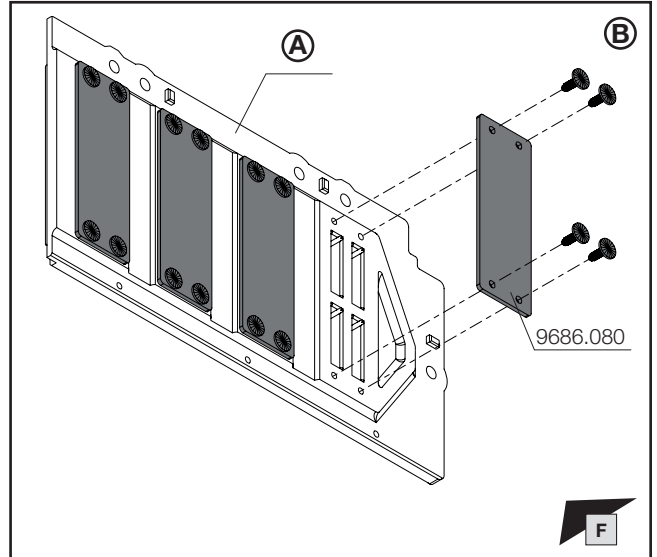
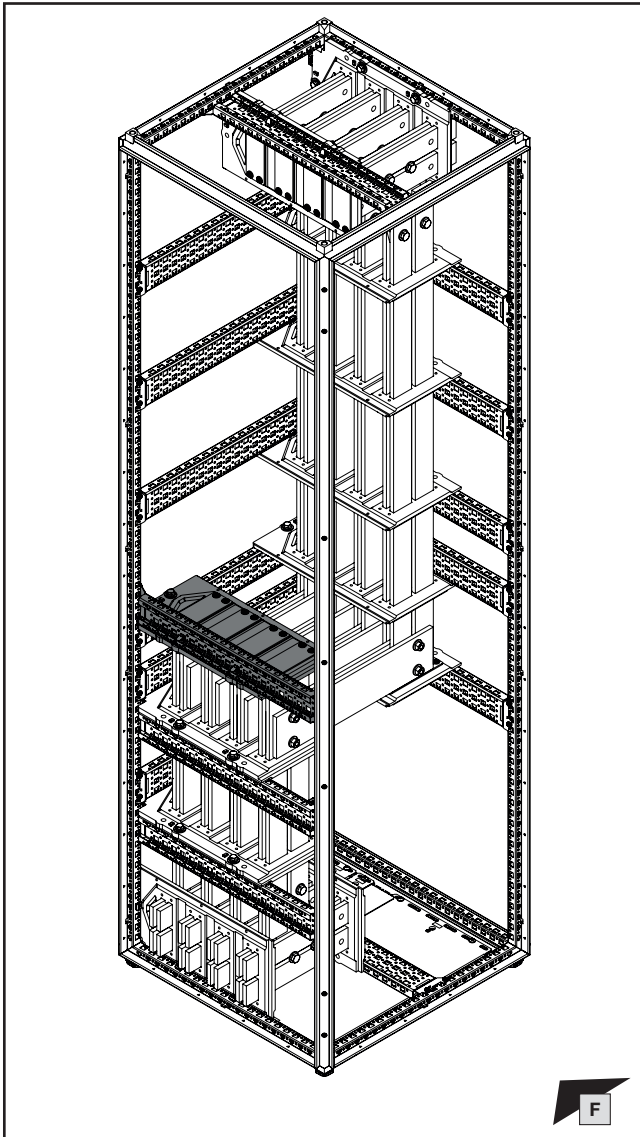

Sammelschiene Abmessung mm Busbar dimension mm Dimensions de la barre mm	Anreihung Baying Juxtaposition	(A) Best.-Nr. Model No. Référence
30 x 10	×	9686.010
50 x 10	×	9686.040

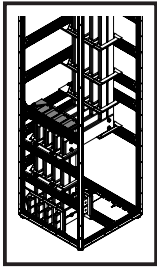

1. Montage Hochführungsfeld – Einbaulage Boden auf Dach
 1. Fitting the riser section – Mounting position: Base section to roof
 1. Zone de montage vertical – position base vers toit

- 1.15 Montage System-Chassis und Sammelschienenhalter
 1.15 Fitting the punched section with mounting flange and busbar support
 1.15 Montage du rail de montage et des supports de jeux de barres

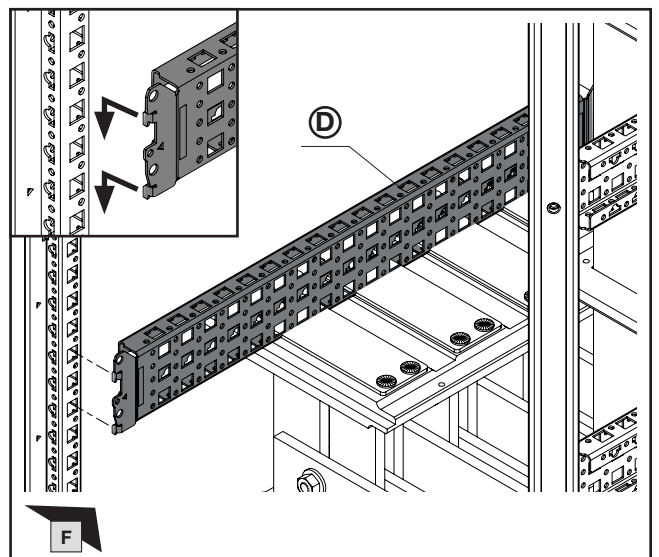
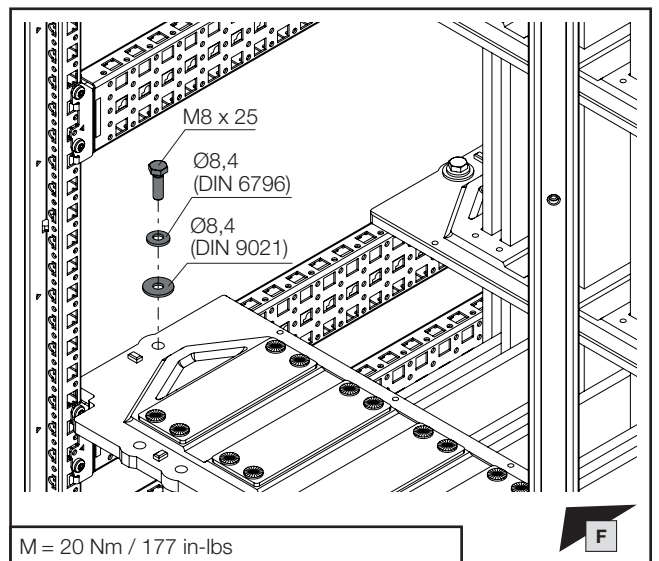
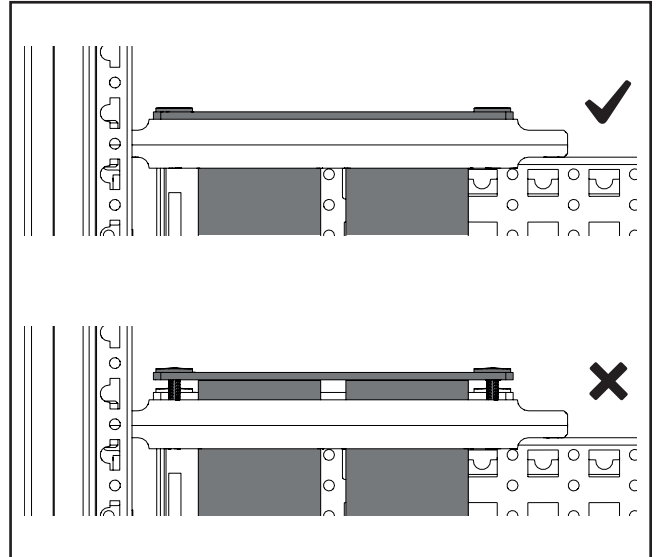
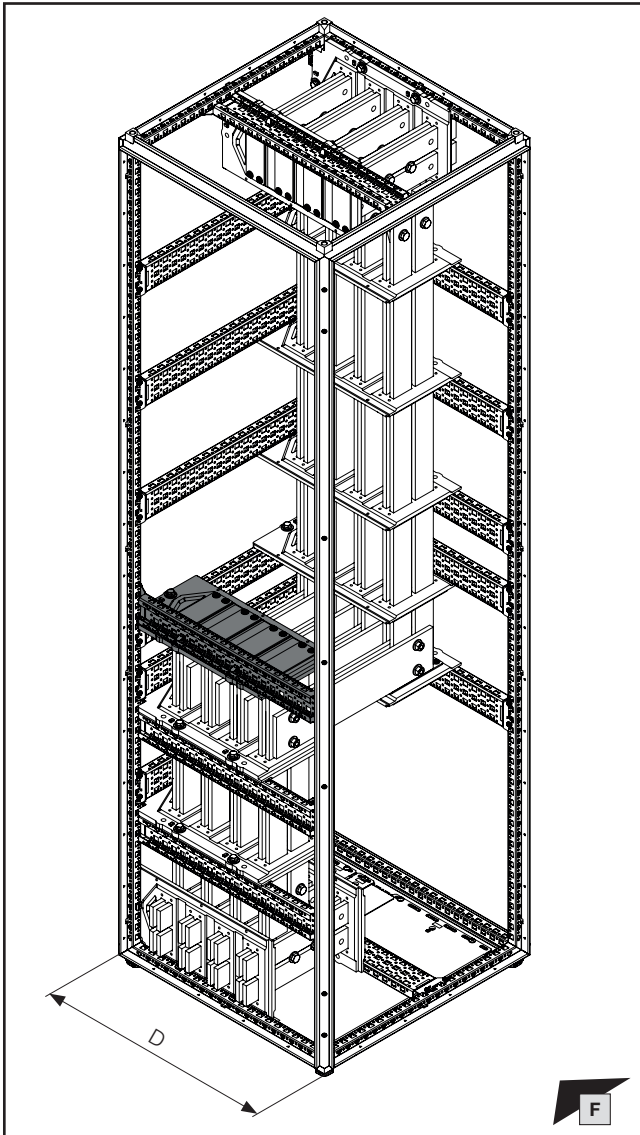

D mm	Best.-Nr. Model No. Référence
600	8617.130
800	8617.140

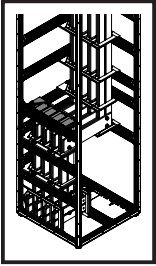

DE EN FR



1. Montage Hochführungsfeld – Einbaulage Boden auf Dach
1. Fitting the riser section – Mounting position: Base section to roof
1. Zone de montage vertical – position base vers toit

- 1.15 Montage System-Chassis und Sammelschienenhalter
- 1.15 Fitting the punched section with mounting flange and busbar support
- 1.15 Montage du rail de montage et des supports de jeux de barres

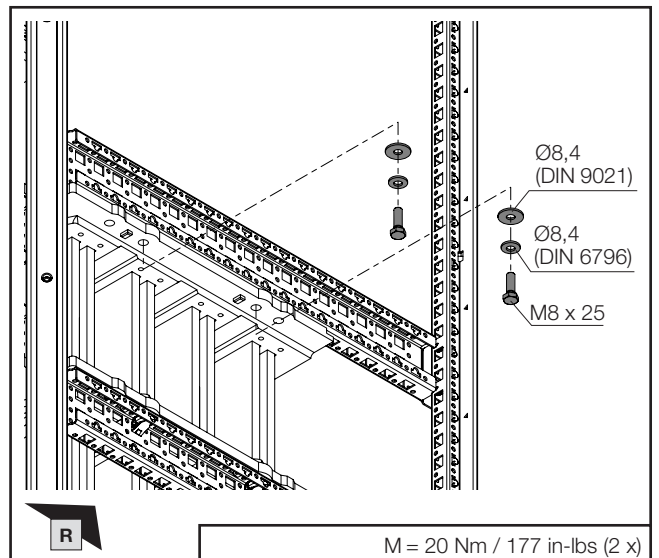
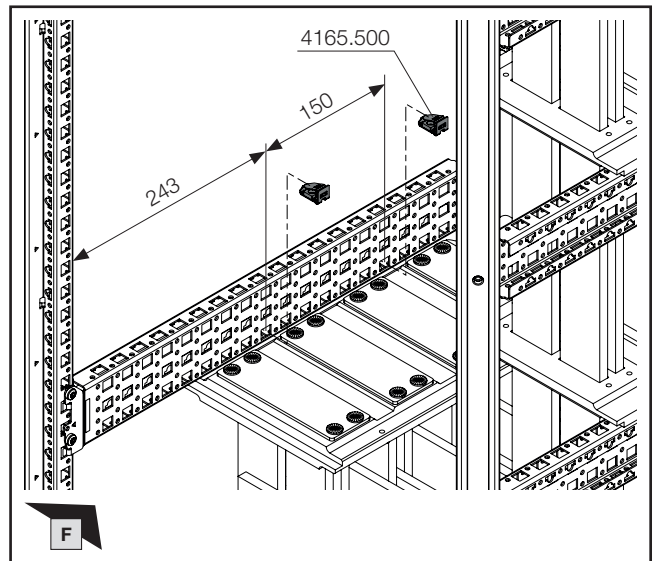
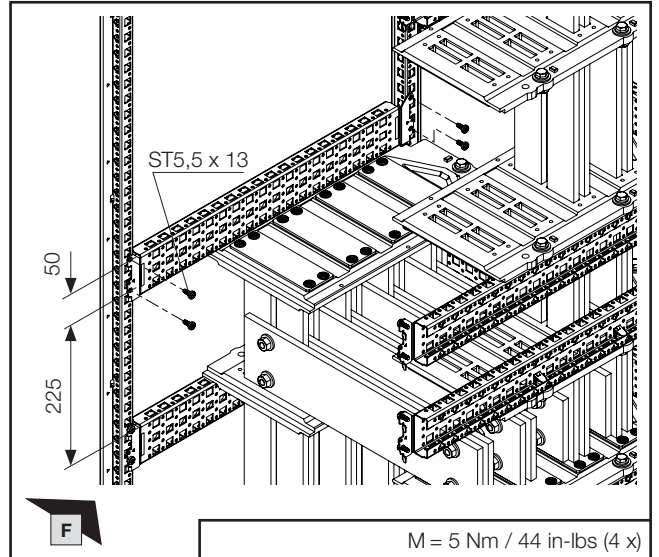
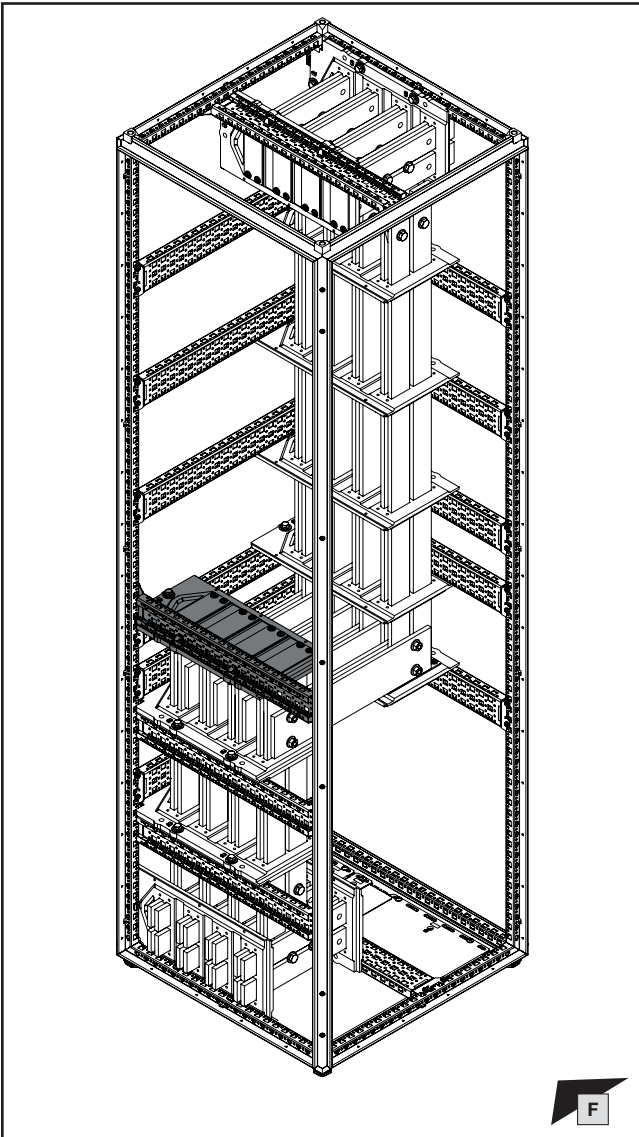

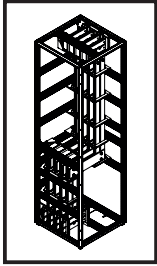

SW16/
SW17

DE EN FR



1. Montage Hochführungsfeld – Einbaulage Boden auf Dach
1. Fitting the riser section – Mounting position: Base section to roof
1. Zone de montage vertical – position base vers toit

- 1.16 Anziehen der Schrauben
- 1.16 Tightening the screws
- 1.16 Serrage des vis

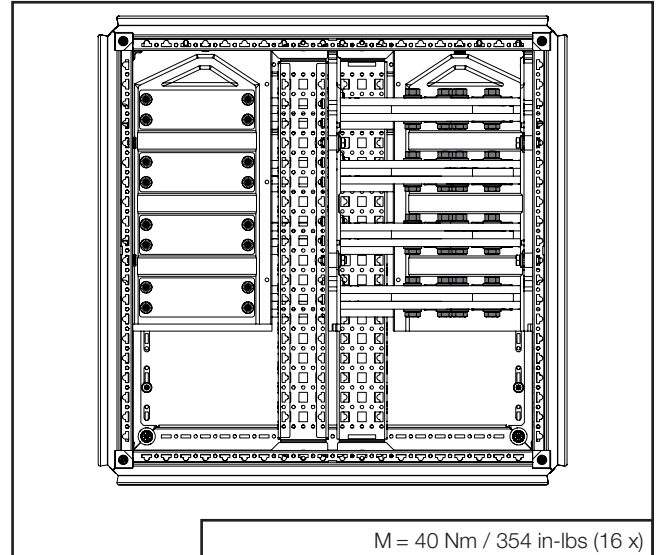
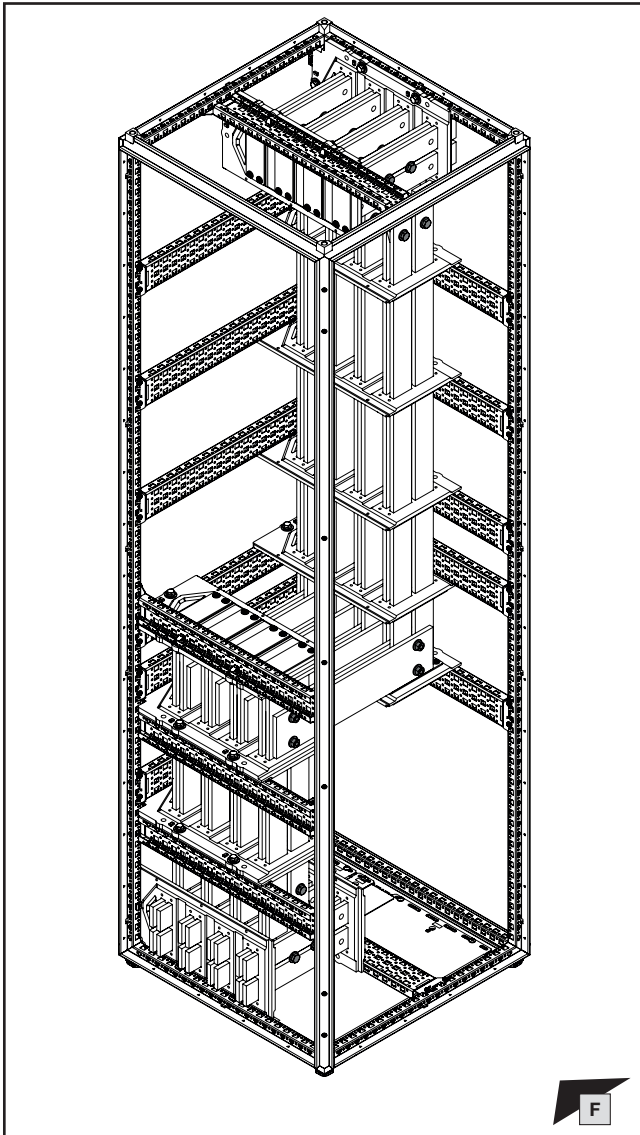

M = 40 Nm / 354 in-lbs (16 x)

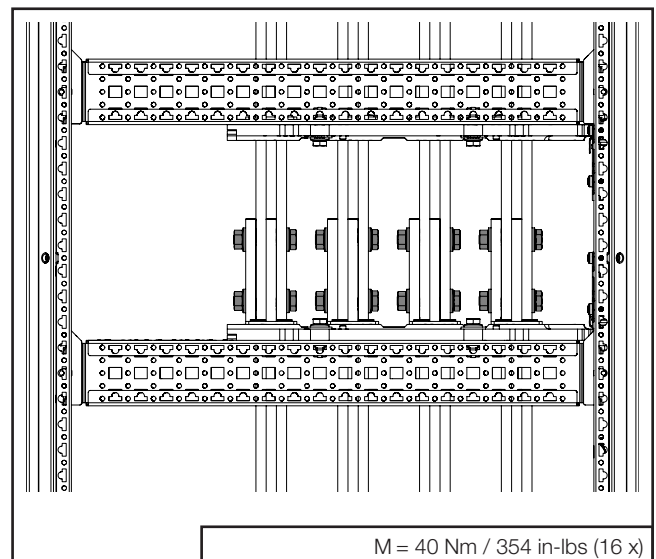

M = 40 Nm / 354 in-lbs (16 x)

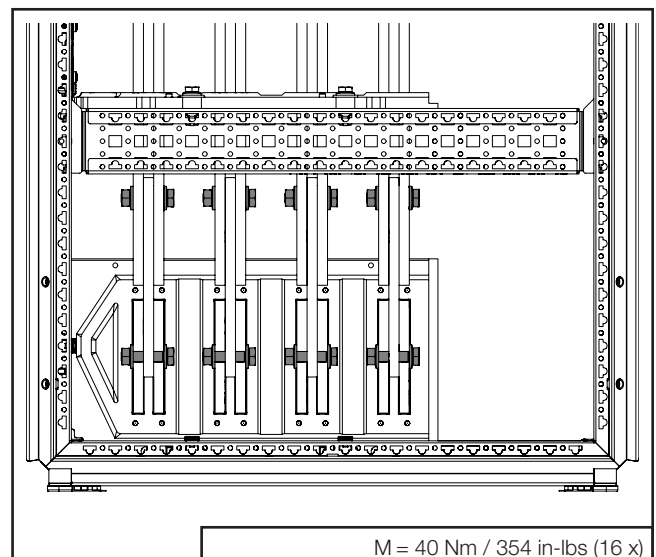

M = 40 Nm / 354 in-lbs (16 x)

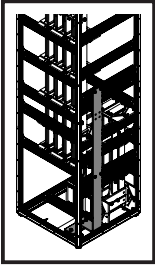

1. Montage Hochführungsfeld – Einbaulage Boden auf Dach
1. Fitting the riser section – Mounting position: Base section to roof
1. Zone de montage vertical – position base vers toit

- 1.17 Montage des unteren PE-/PEN-Sammelschienensystems
 1.17 Fitting the lower PE/PEN busbar system
 1.17 Montage des jeux de barres Terre / Terre-Neutre inférieurs

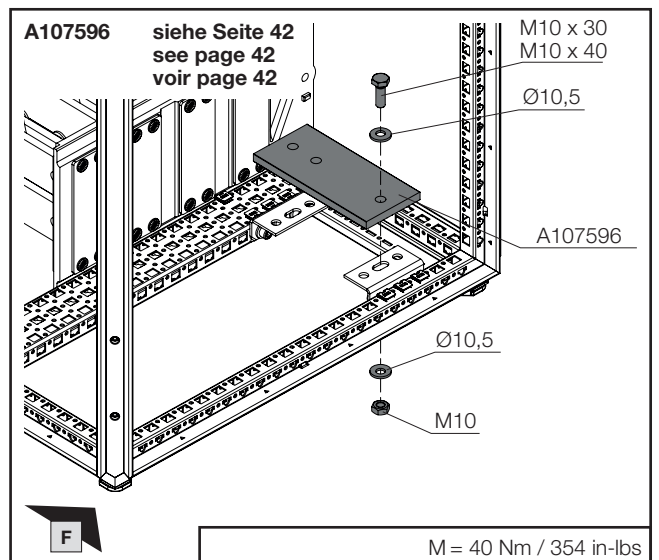
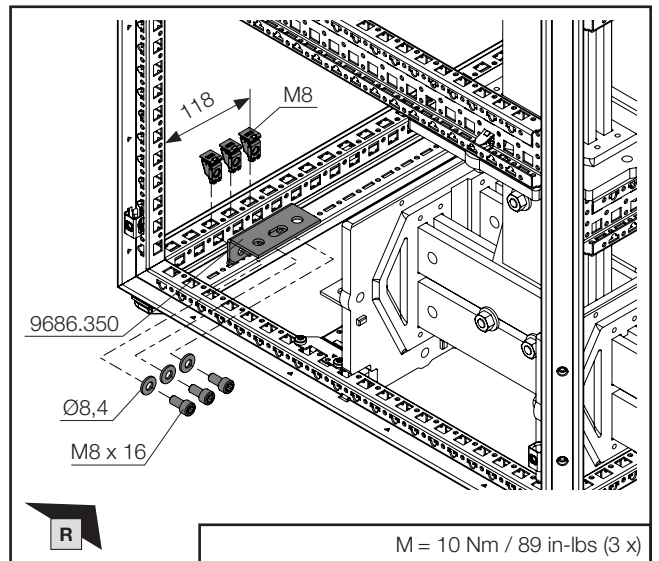
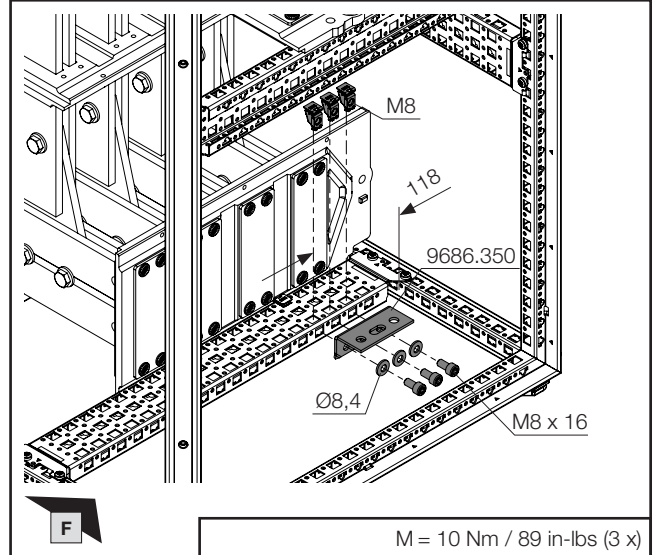
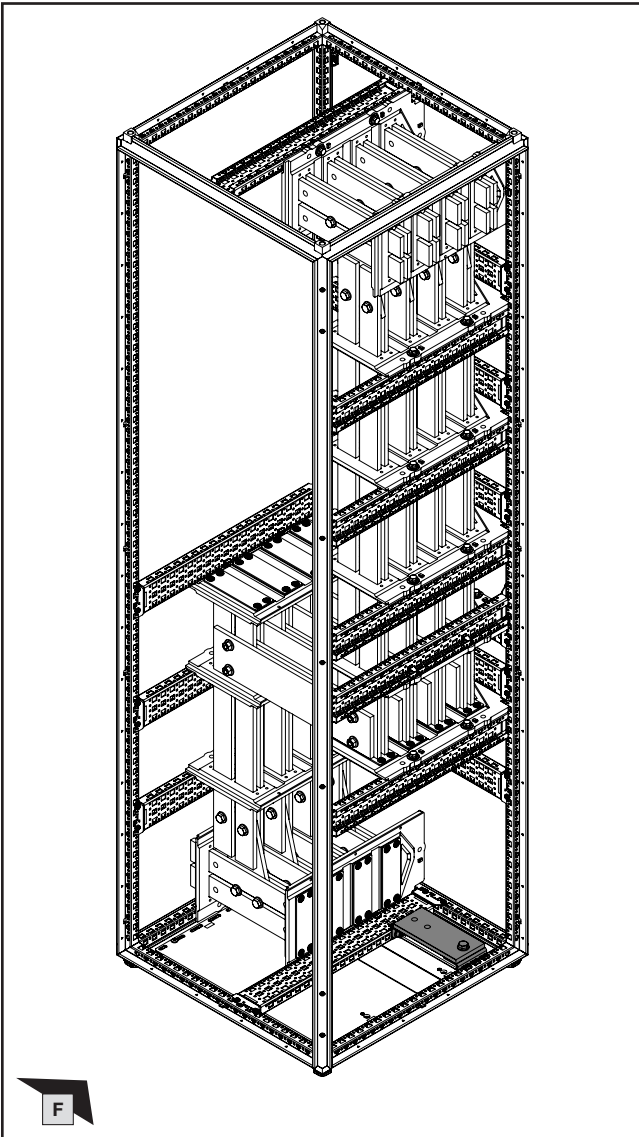

Montageanleitung VX25 Ri4Power – Schalt- und Energieverteilanlagen-System
 Assembly instructions VX25 Ri4Power – Switchgear and power distribution system
 Notice de montage VX25 Ri4Power – Distribution de courant
 DE/EN/FR

Schranksystem VX25 – Technische Dokumentation – Schutzleiteranschluss, Strombelastbarkeit
 VX25 Enclosure System – Technical documentation – PE conductor connection, current carrying capacity
 Armoires électriques VX25 – Manuel technique – Raccordement de mise à la terre et intensités maximales admissibles
 DE EN FR

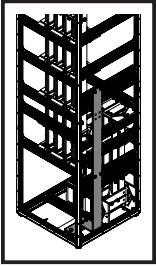

1. Montage Hochführungsfeld – Einbaulage Boden auf Dach
1. Fitting the riser section – Mounting position: Base section to roof
1. Zone de montage vertical – position base vers toit

- 1.17 Montage des unteren PE-/PEN-Sammelschienensystems
- 1.17 Fitting the lower PE/PEN busbar system
- 1.17 Montage des jeux de barres Terre / Terre-Neutre inférieurs

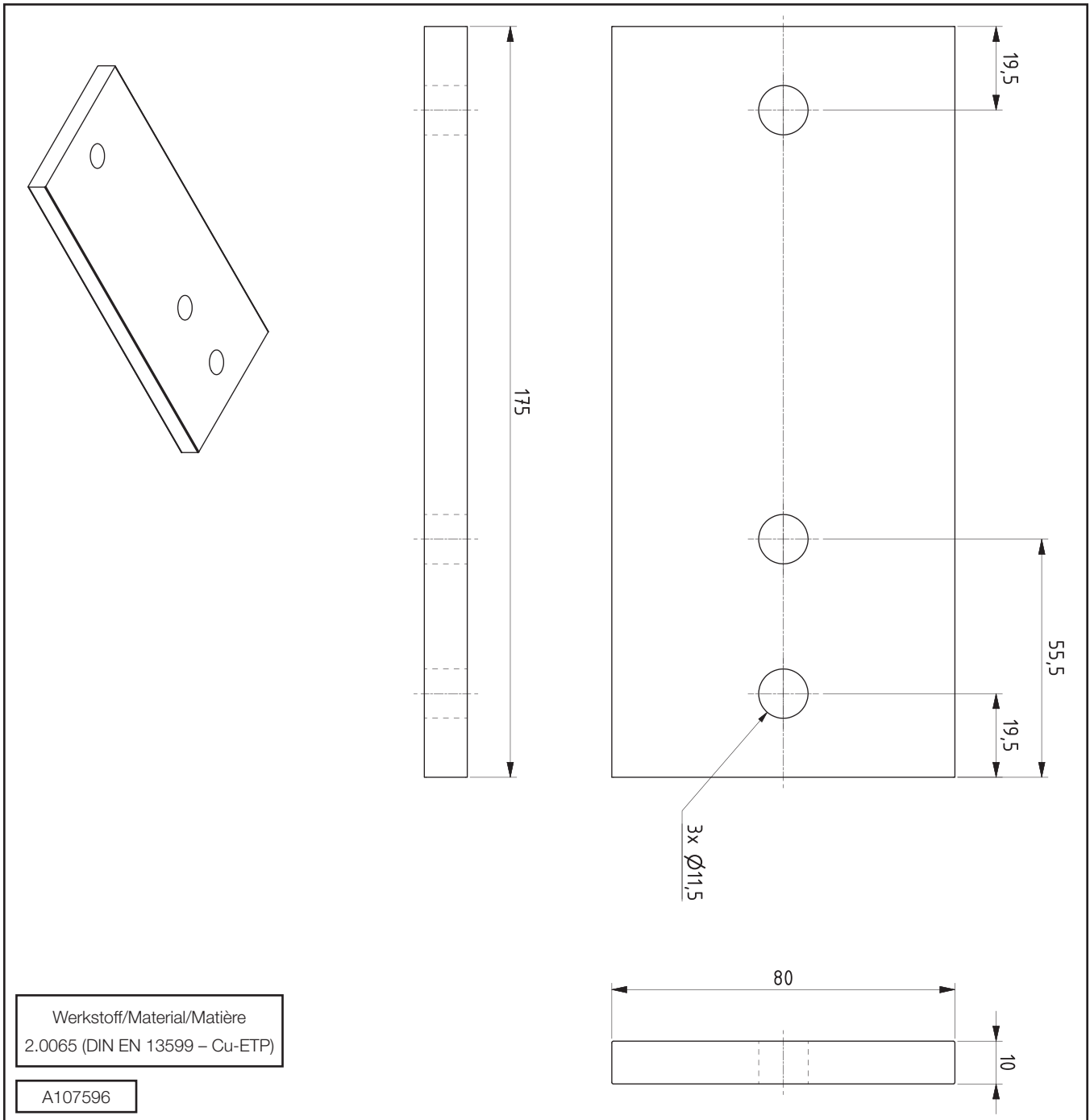

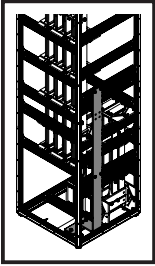

1. Montage Hochführungsfeld – Einbaulage Boden auf Dach
1. Fitting the riser section – Mounting position: Base section to roof
1. Zone de montage vertical – position base vers toit

- 1.17 Montage des unteren PE-/PEN-Sammelschienensystems
- 1.17 Fitting the lower PE/PEN busbar system
- 1.17 Montage des jeux de barres Terre / Terre-Neutre inférieurs

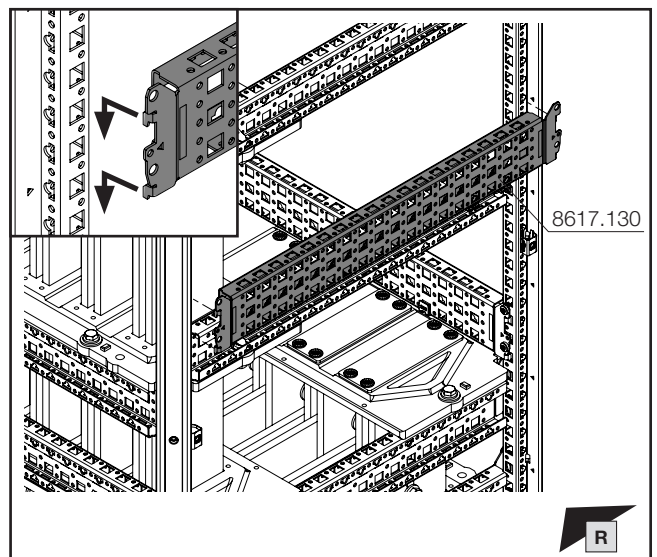
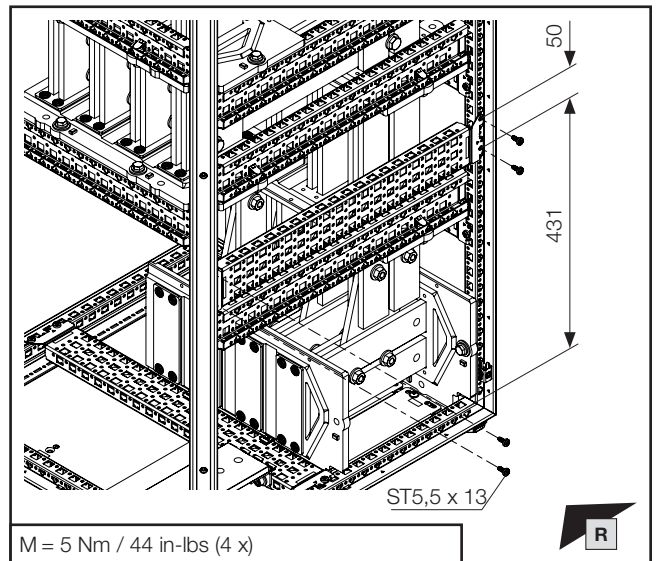
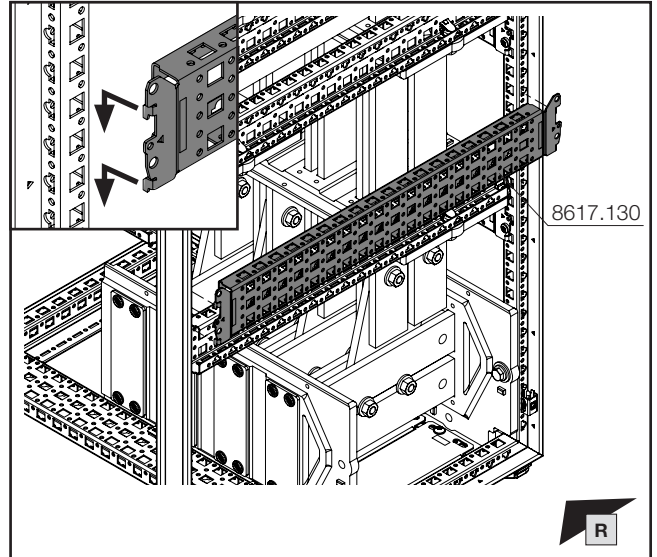
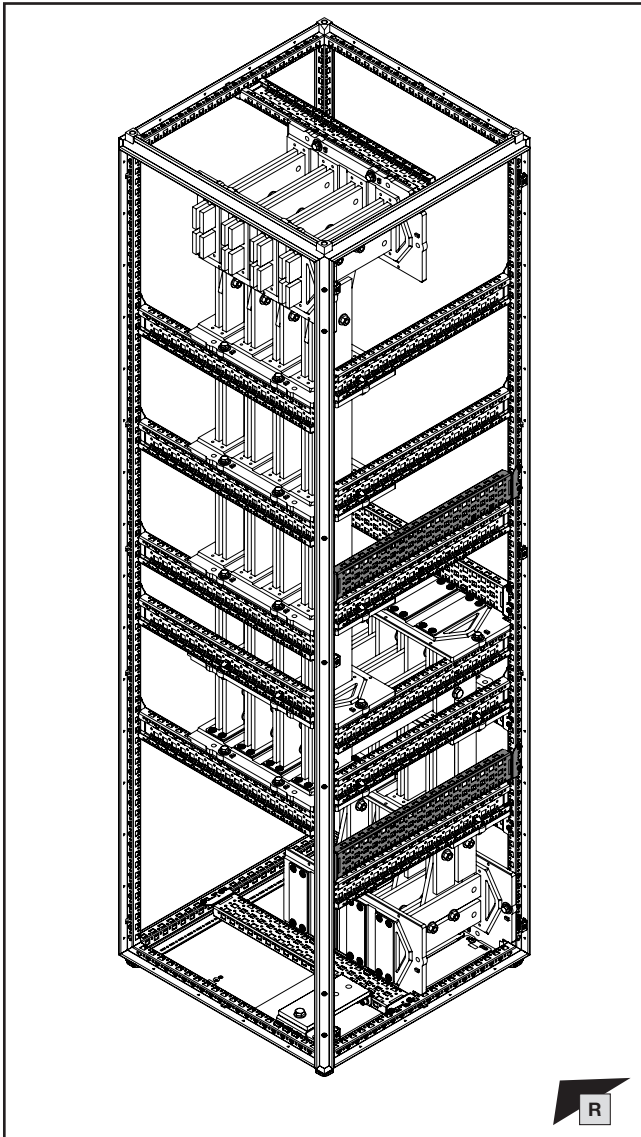

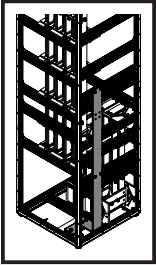

- 1. Montage Hochführungsfeld – Einbaulage Boden auf Dach
- 1. Fitting the riser section – Mounting position: Base section to roof
- 1. Zone de montage vertical – position base vers toit

- 1.17 Montage des unteren PE-/PEN-Sammelschienensystems
- 1.17 Fitting the lower PE/PEN busbar system
- 1.17 Montage des jeux de barres Terre / Terre-Neutre inférieurs

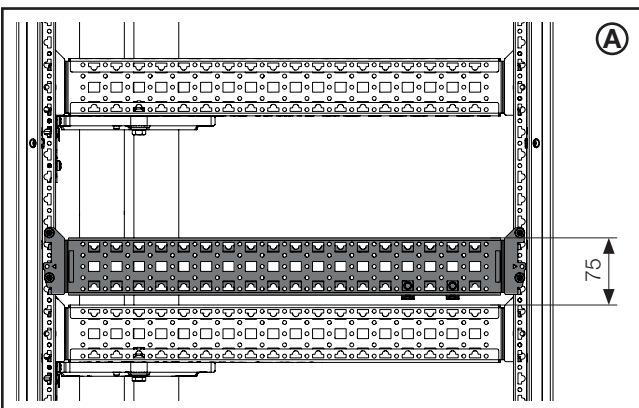
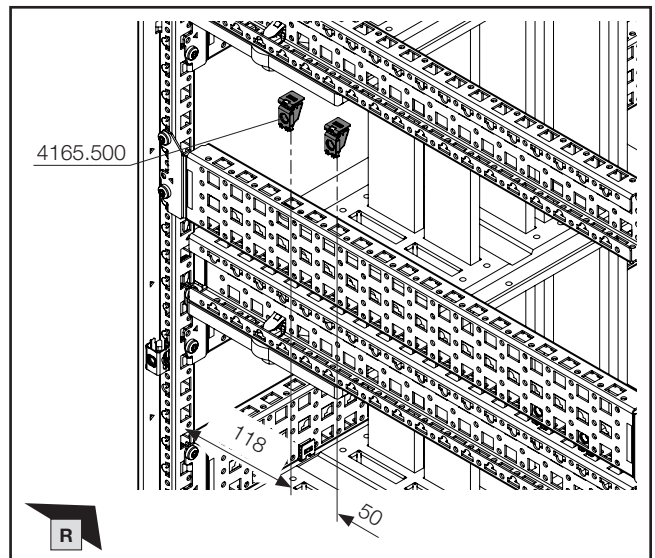
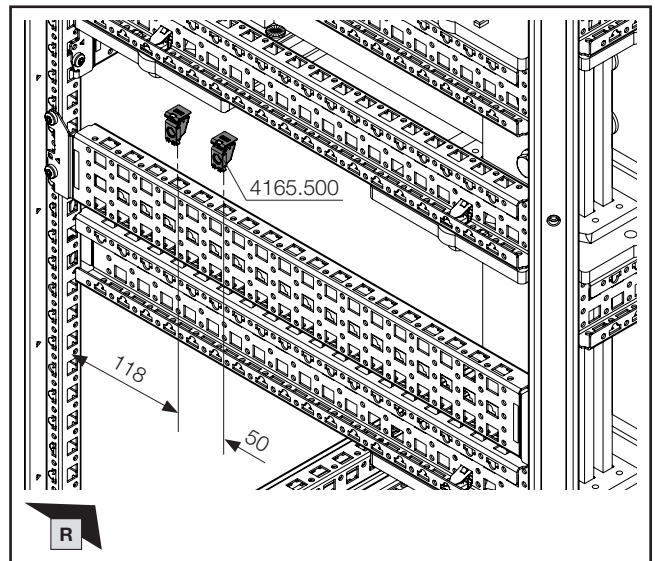
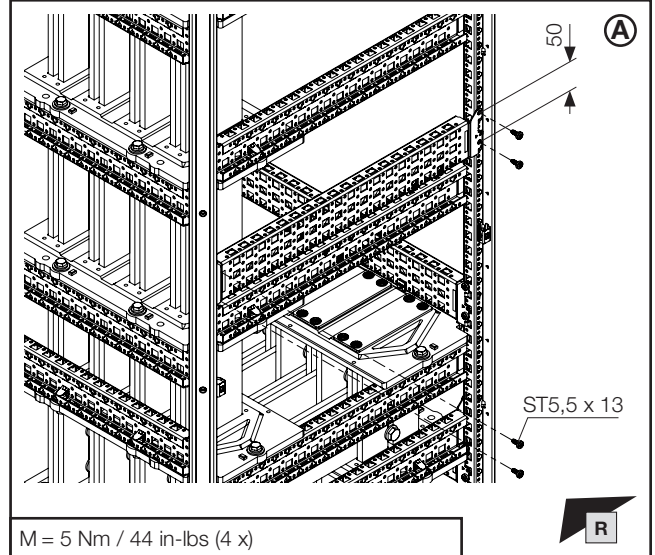
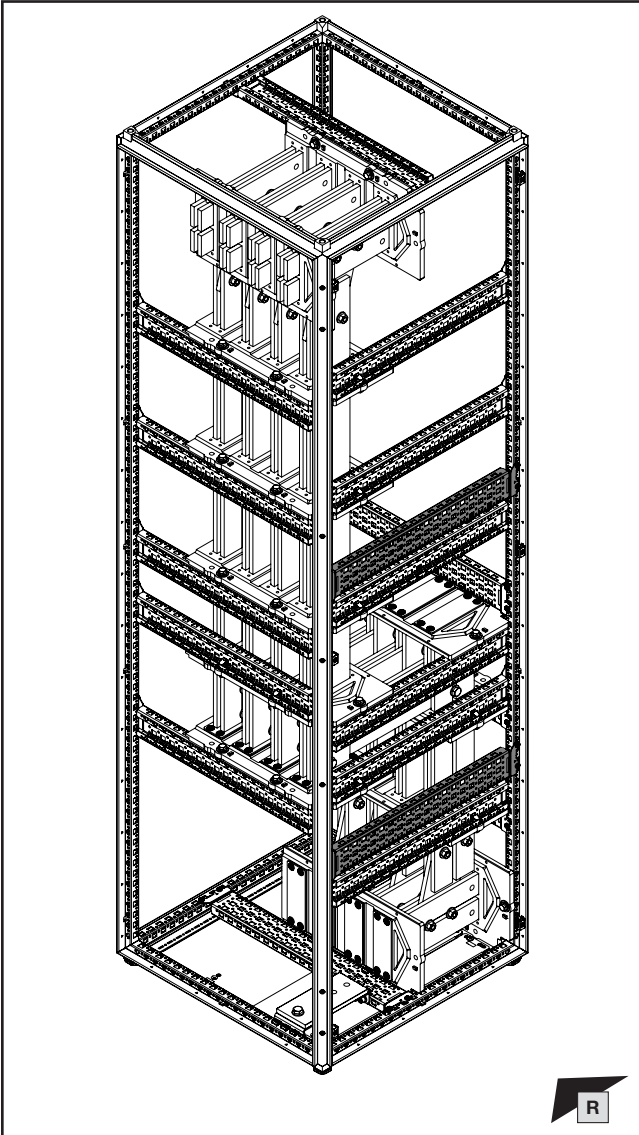

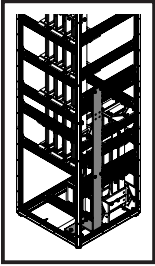

SW13



SW16/
SW17



DE EN FR



1. Montage Hochführungsfeld – Einbaulage Boden auf Dach
1. Fitting the riser section – Mounting position: Base section to roof
1. Zone de montage vertical – position base vers toit

- 1.17 Montage des unteren PE-/PEN-Sammelschienensystems
- 1.17 Fitting the lower PE/PEN busbar system
- 1.17 Montage des jeux de barres Terre / Terre-Neutre inférieurs

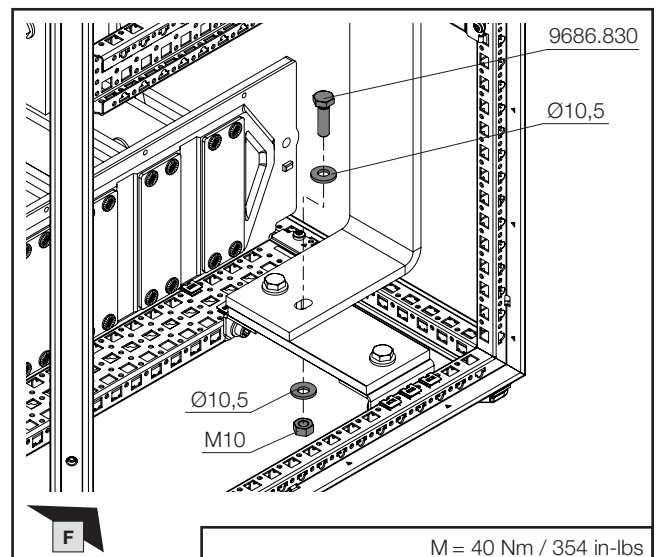
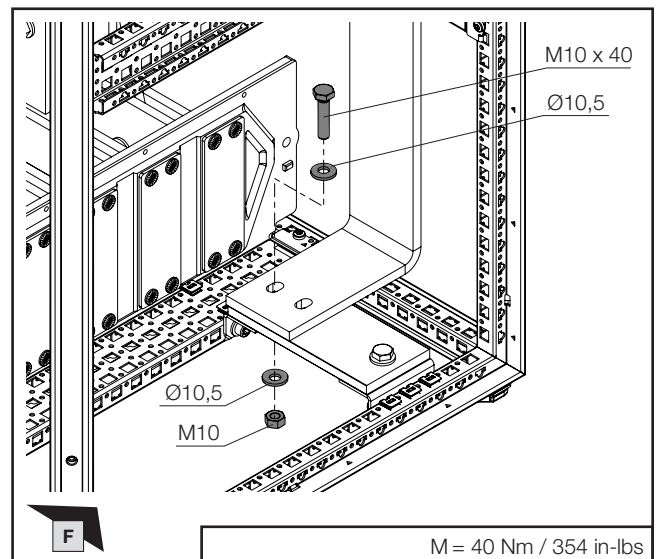
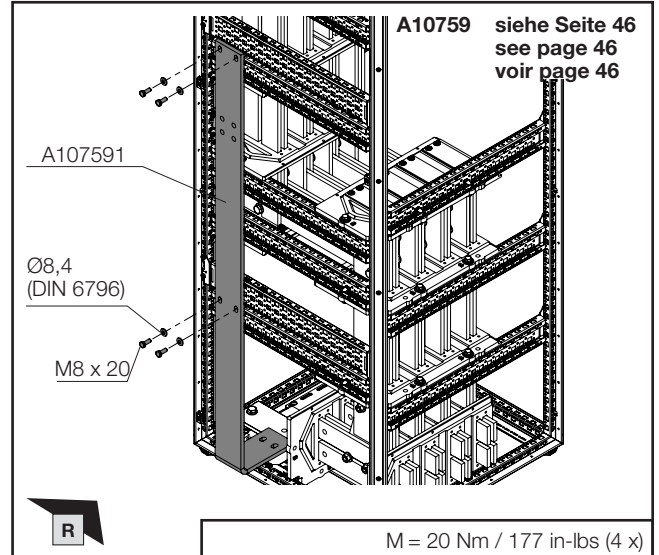
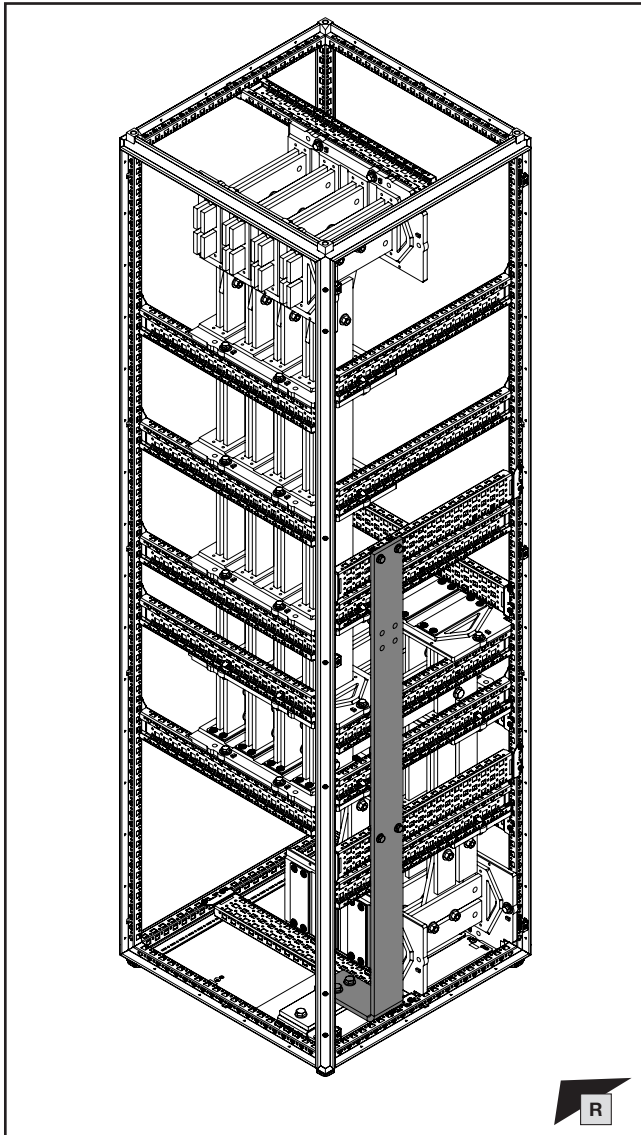

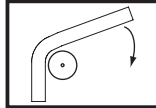
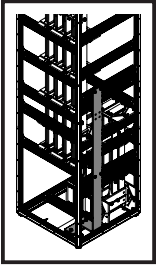

1. Montage Hochführungsfeld – Einbaulage Boden auf Dach
1. Fitting the riser section – Mounting position: Base section to roof
1. Zone de montage vertical – position base vers toit

- 1.17 Montage des unteren PE-/PEN-Sammelschienensystems
- 1.17 Fitting the lower PE/PEN busbar system
- 1.17 Montage des jeux de barres Terre / Terre-Neutre inférieurs

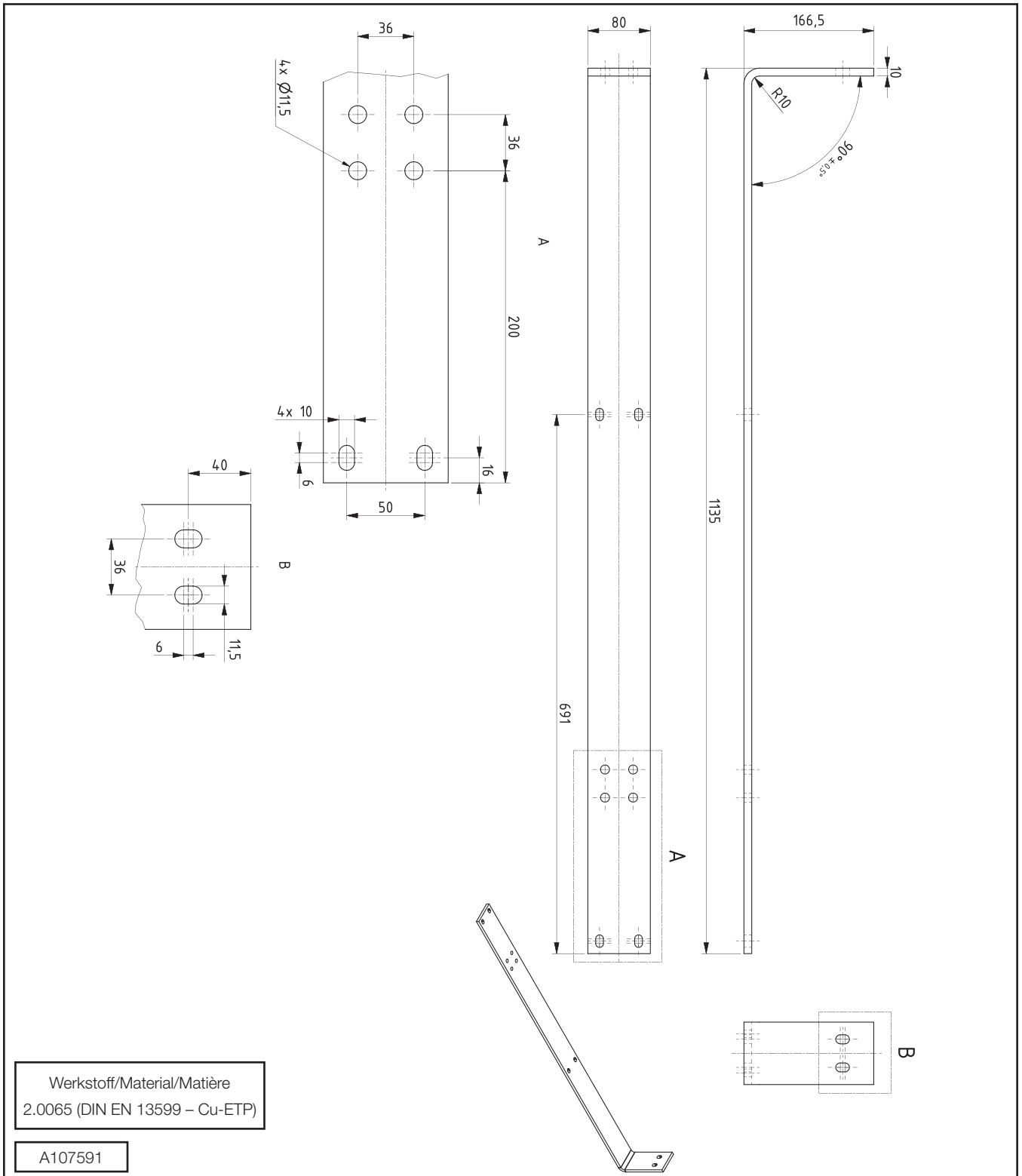

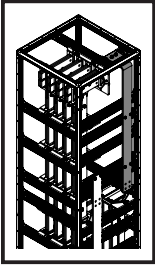

1. Montage Hochführungsfeld – Einbaulage Boden auf Dach
1. Fitting the riser section – Mounting position: Base section to roof
1. Zone de montage vertical – position base vers toit

- 1.18 Montage des oberen PE-/PEN-Sammelschienensystems
- 1.18 Fitting the upper PE/PEN busbar system
- 1.18 Montage des jeux de barres Terre / Terre-Neutre supérieurs

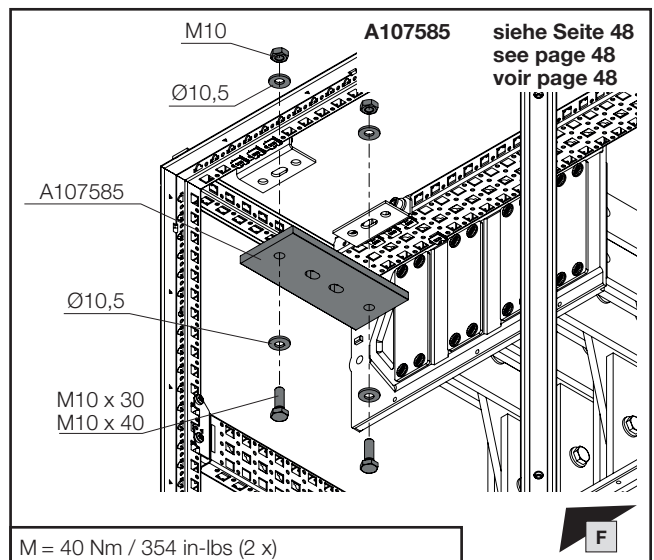
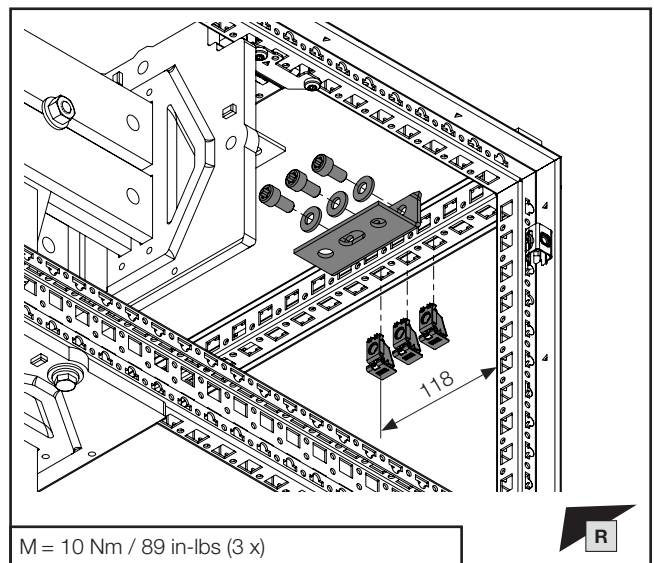
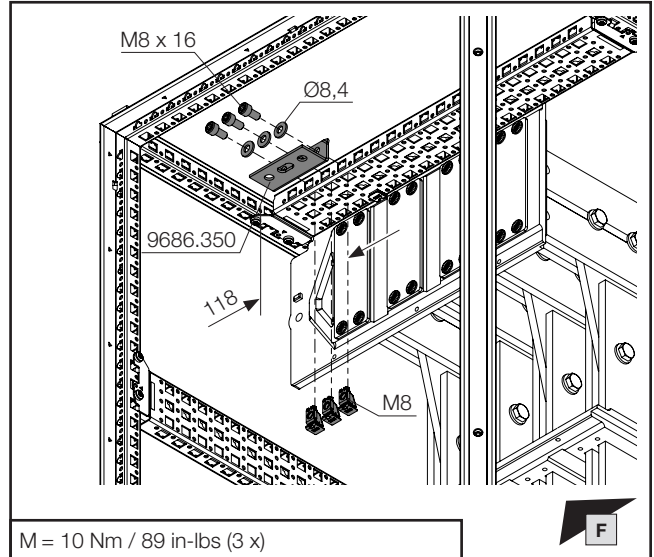
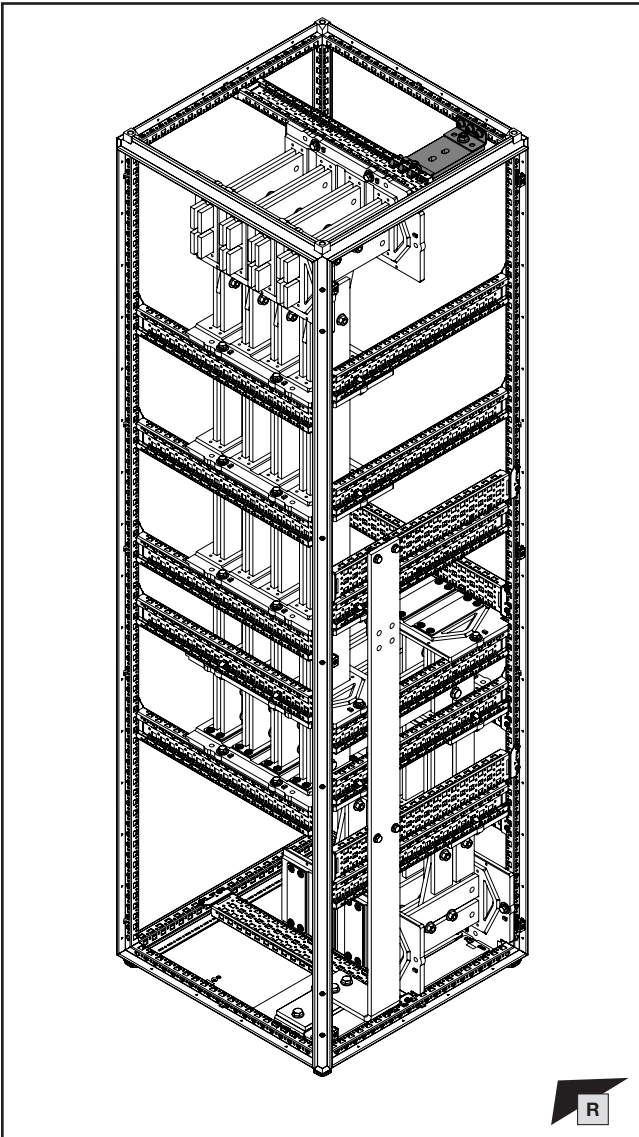

Montageanleitung VX25 Ri4Power – Schalt- und Energieverteilanlagen-System
 Assembly instructions VX25 Ri4Power – Switchgear and power distribution system
 Notice de montage VX25 Ri4Power – Distribution de courant



Schranksystem VX25 – Technische Dokumentation – Schutzleiteranschluss, Strombelastbarkeit
 VX25 Enclosure System – Technical documentation – PE conductor connection, current carrying capacity
 Armoires électriques VX25 – Manuel technique – Raccordement de mise à la terre et intensités maximales admissibles



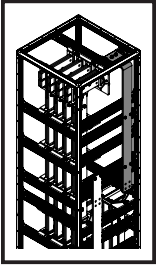

1. Montage Hochführungsfeld – Einbaulage Boden auf Dach
1. Fitting the riser section – Mounting position: Base section to roof
1. Zone de montage vertical – position base vers toit

- 1.18 Montage des oberen PE-/PEN-Sammelschienensystems
- 1.18 Fitting the upper PE/PEN busbar system
- 1.18 Montage des jeux de barres Terre / Terre-Neutre supérieurs

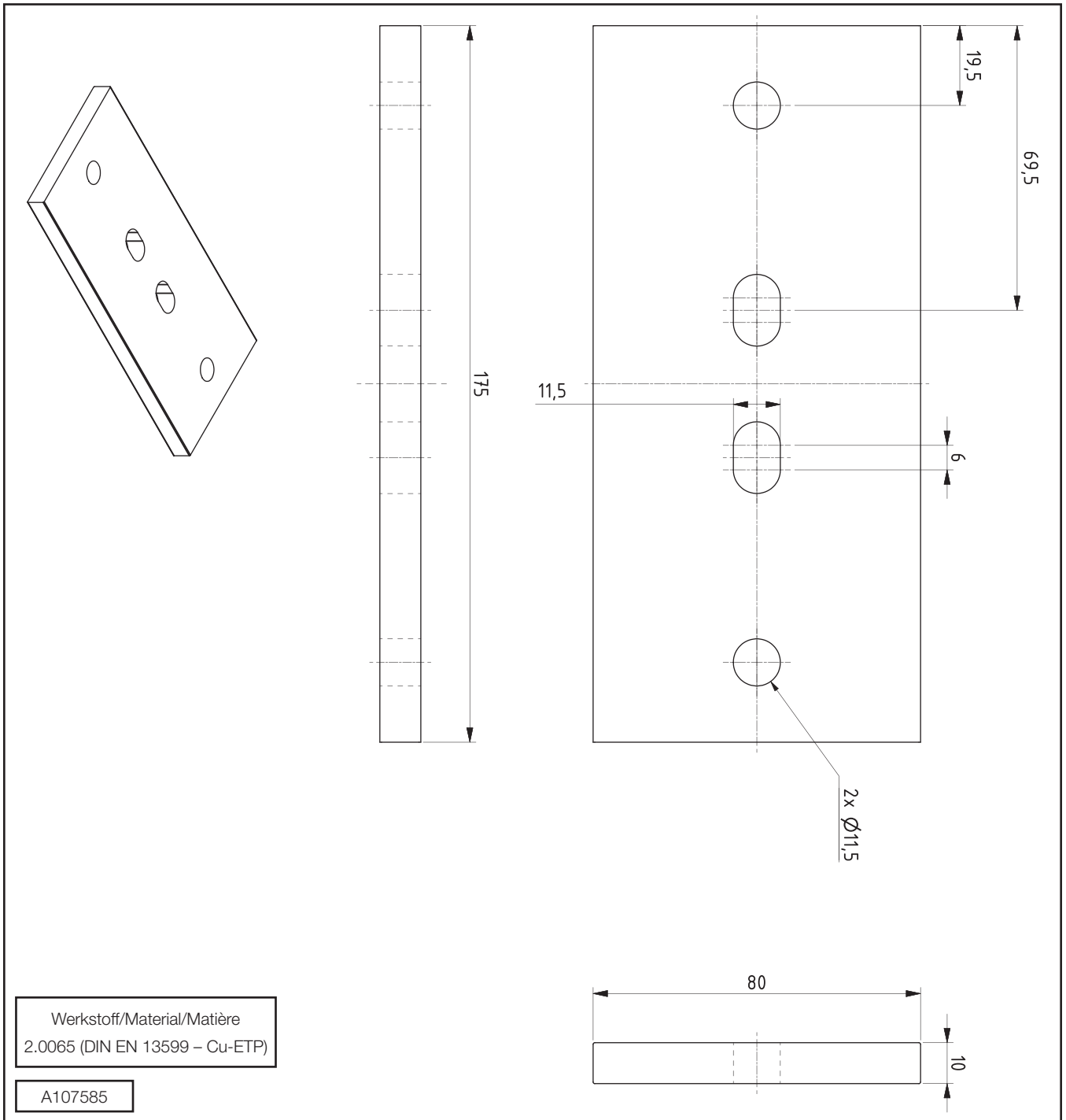

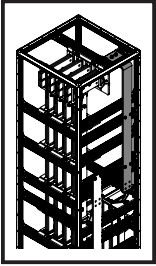

- 1. Montage Hochführungsfeld – Einbaulage Boden auf Dach
- 1. Fitting the riser section – Mounting position: Base section to roof
- 1. Zone de montage vertical – position base vers toit

- 1.18 Montage des oberen PE-/PEN-Sammelschienensystems
- 1.18 Fitting the upper PE/PEN busbar system
- 1.18 Montage des jeux de barres Terre / Terre-Neutre supérieurs

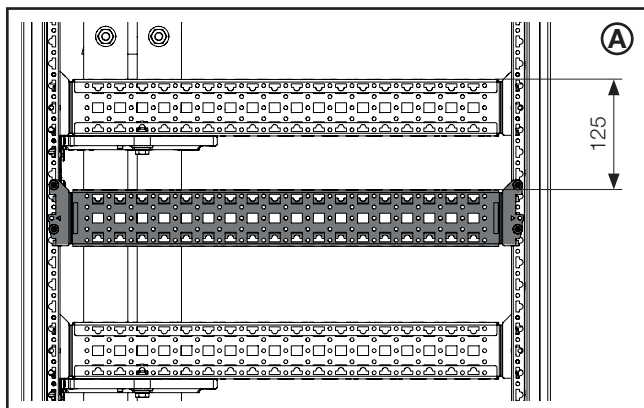
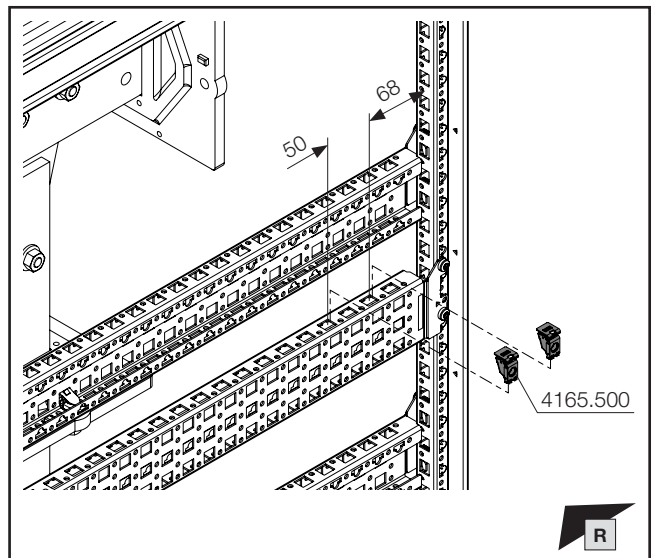
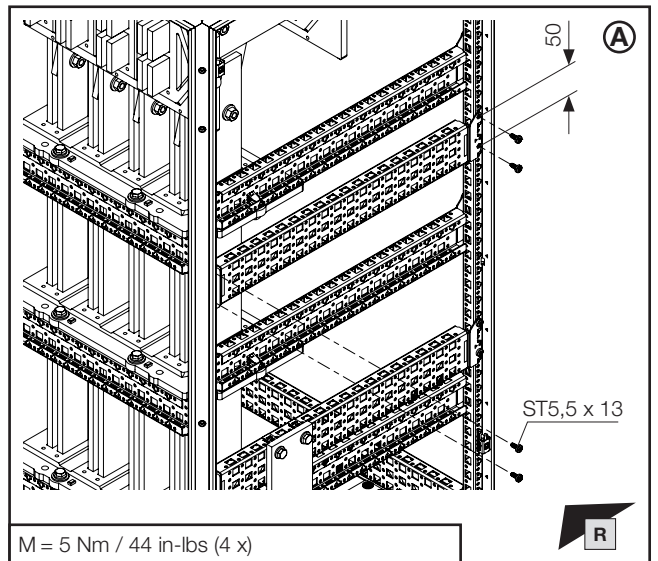
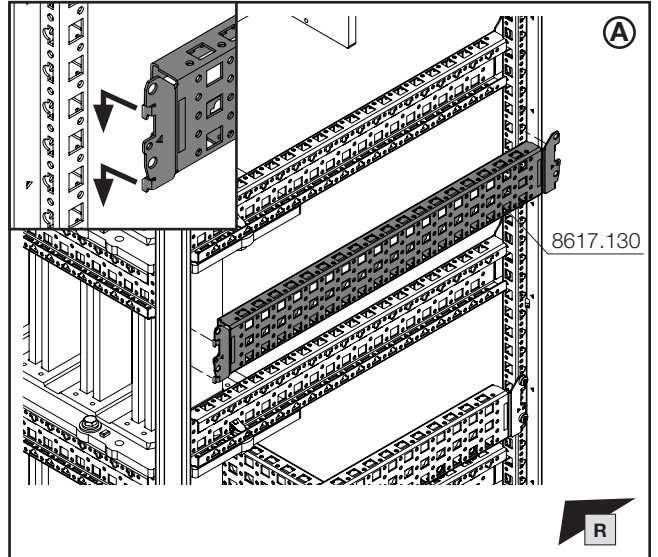
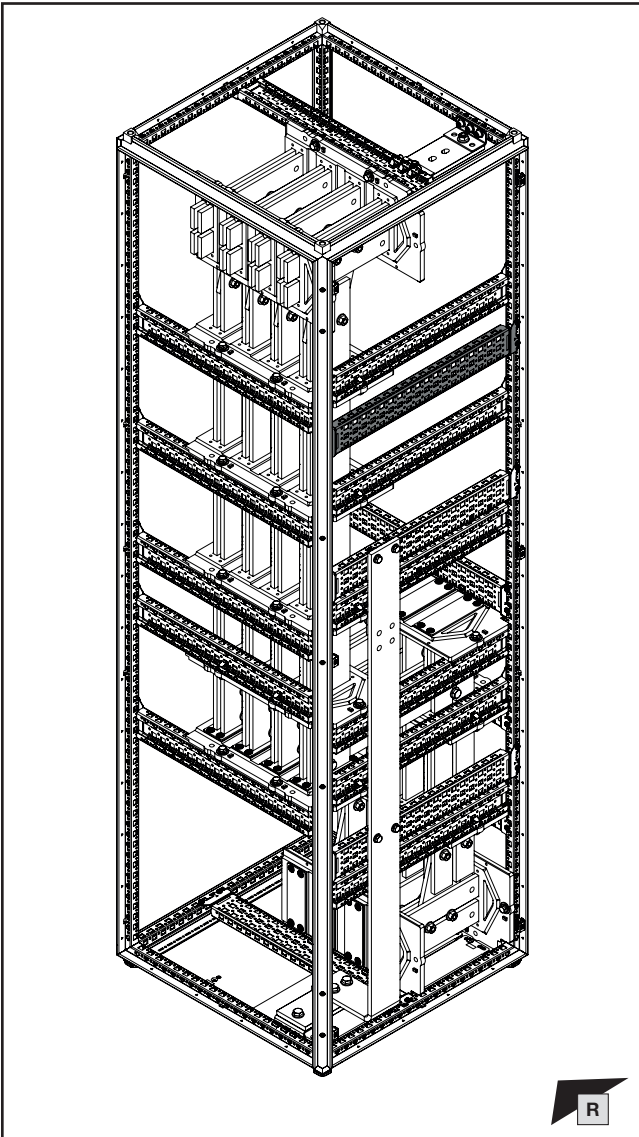

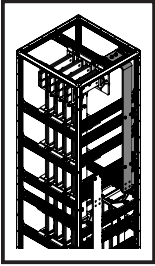

SW13



SW16/
SW17



DE EN FR



1. Montage Hochführungsfeld – Einbaulage Boden auf Dach
1. Fitting the riser section – Mounting position: Base section to roof
1. Zone de montage vertical – position base vers toit

- 1.18 Montage des oberen PE-/PEN-Sammelschienensystems
- 1.18 Fitting the upper PE/PEN busbar system
- 1.18 Montage des jeux de barres Terre / Terre-Neutre supérieurs

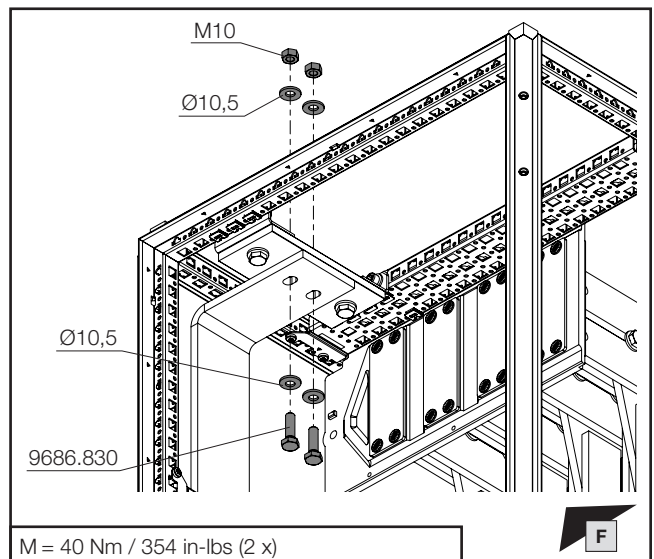
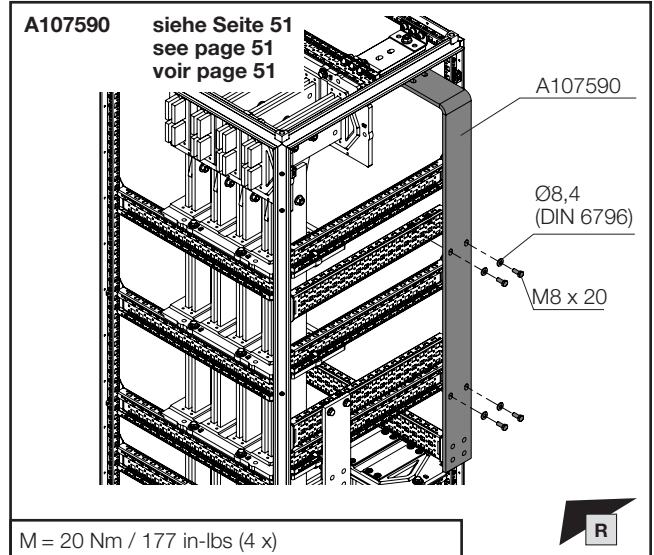
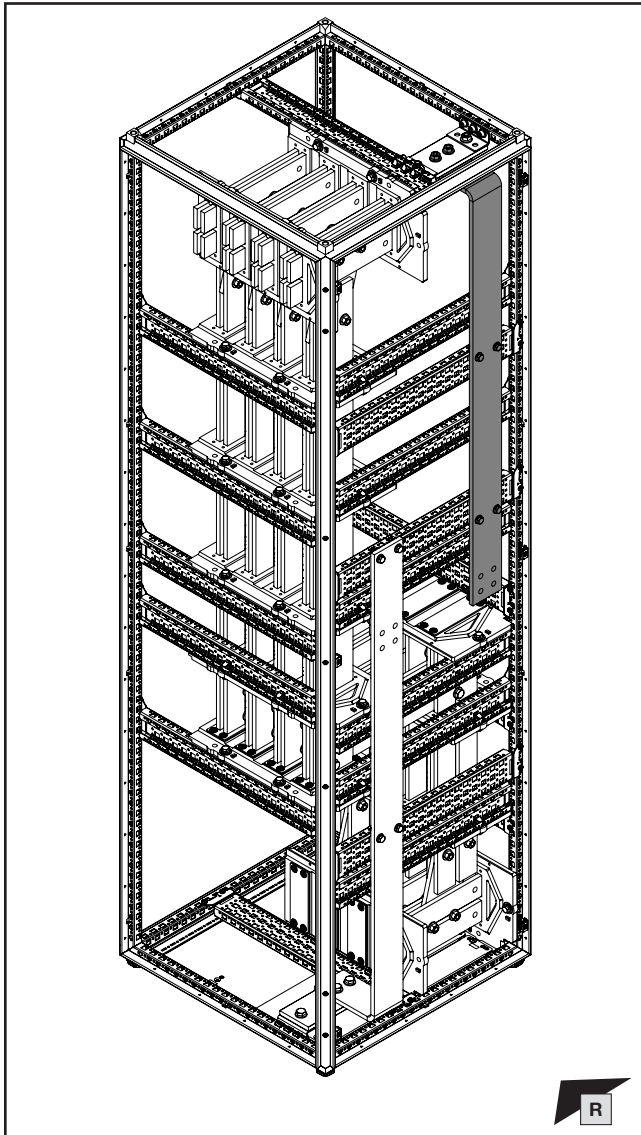

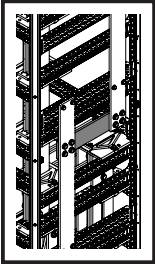

SW16/
SW17



1. Montage Hochführungsfeld – Einbaulage Boden auf Dach
1. Fitting the riser section – Mounting position: Base section to roof
1. Zone de montage vertical – position base vers toit

- 1.19 Verbindung des oberen und unteren PE-/PEN-Sammel-schienensystems
 1.19 Connecting the upper and lower PE/PEN busbar system
 1.19 Raccordement des jeux de barres Terre / Terre-Neutre supérieurs et inférieurs

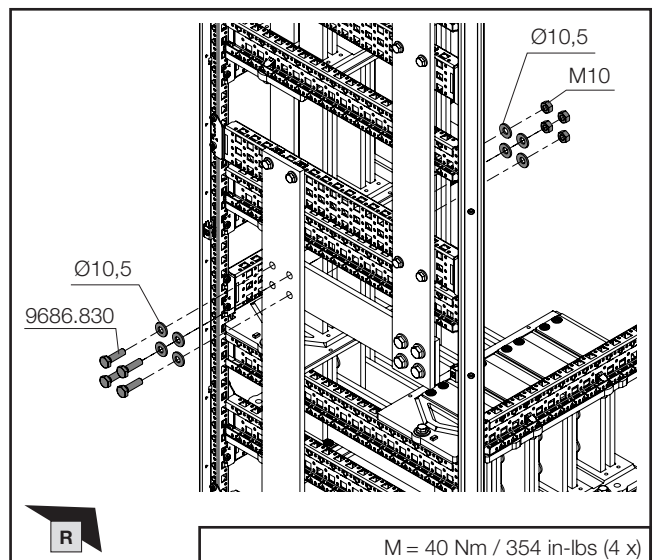
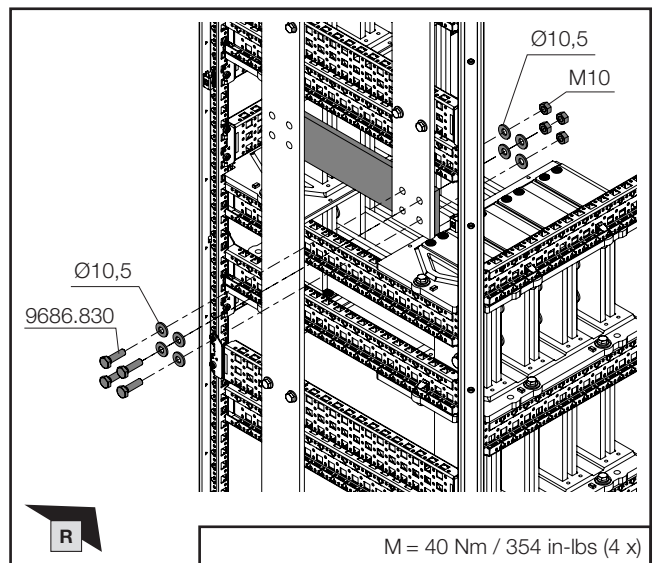
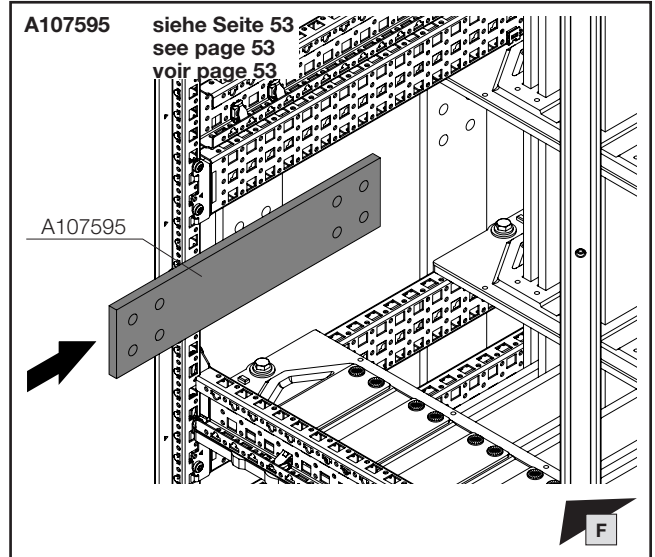
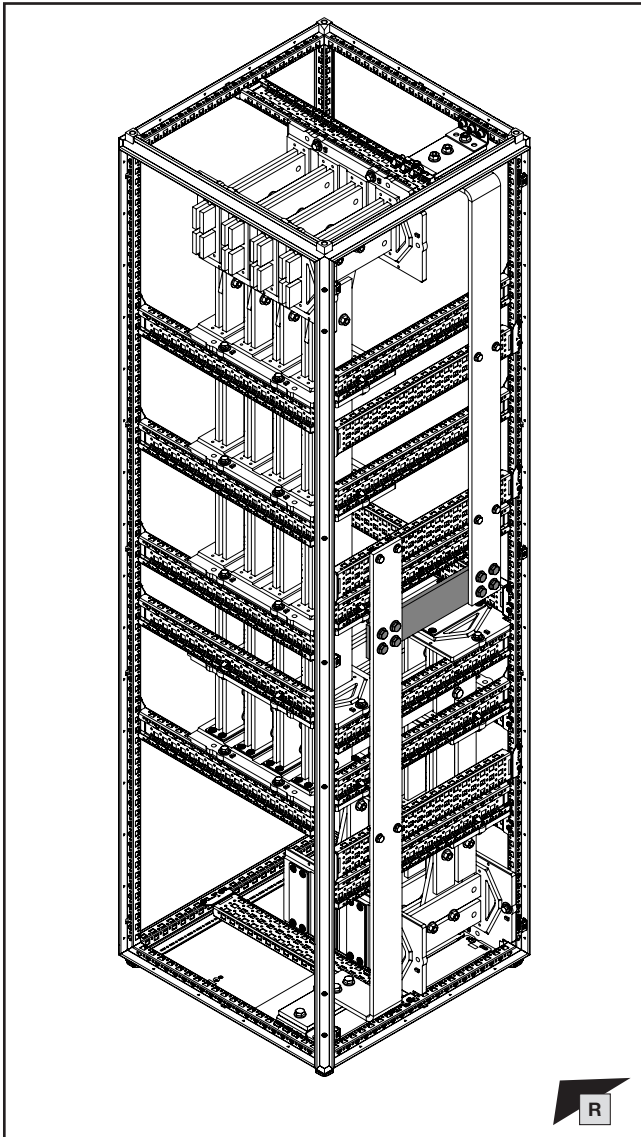

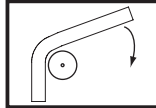
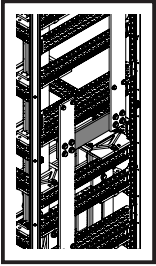

1. Montage Hochführungsfeld – Einbaulage Boden auf Dach
1. Fitting the riser section – Mounting position: Base section to roof
1. Zone de montage vertical – position base vers toit

- 1.19 Verbindung des oberen und unteren PE-/PEN-Sammelschienensystems
- 1.19 Connecting the upper and lower PE/PEN busbar system
- 1.19 Raccordement des jeux de barres Terre / Terre-Neutre supérieurs et inférieurs

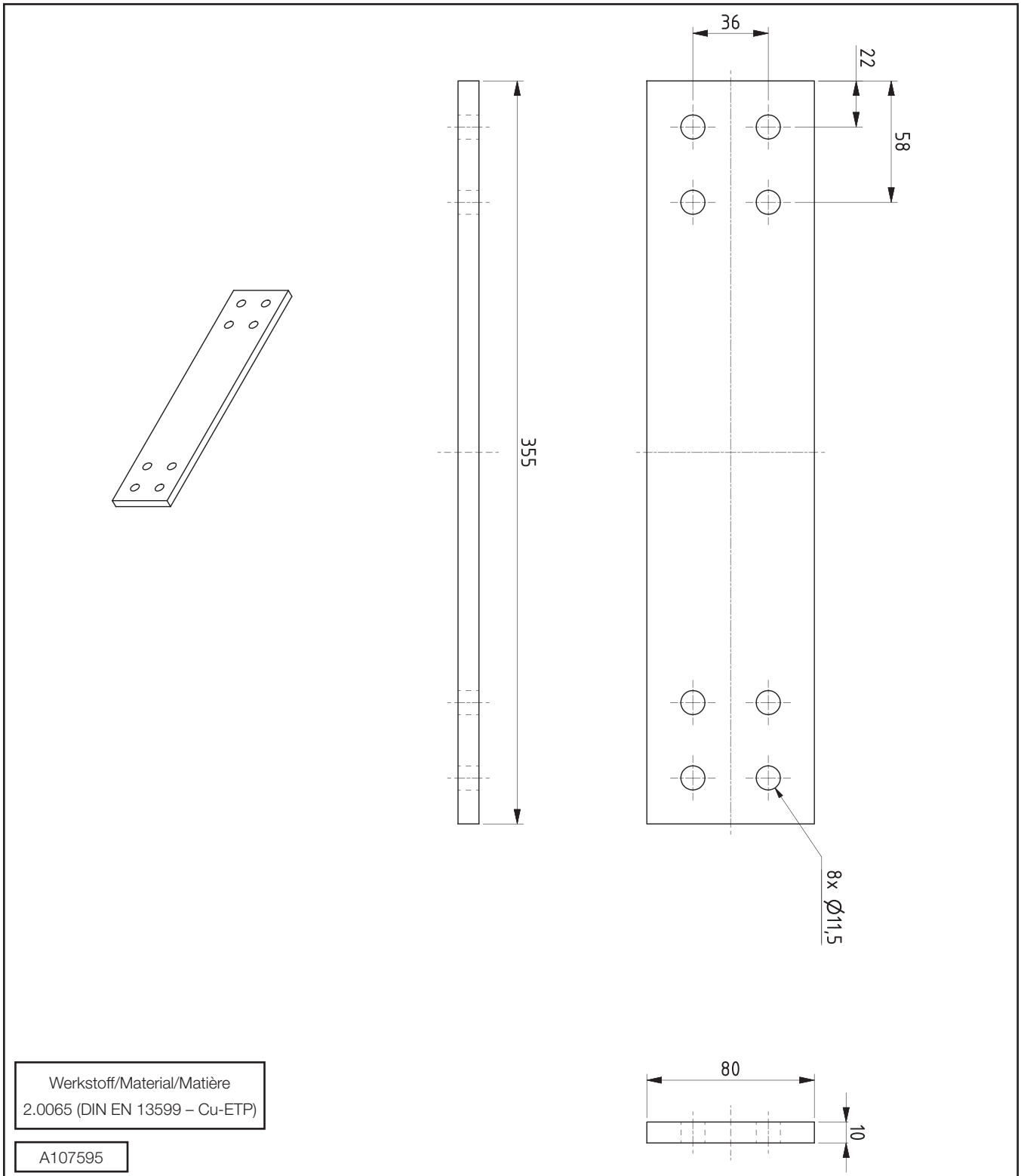

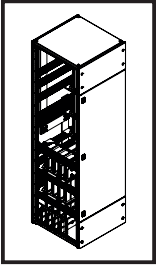

1. Montage Hochführungsfeld – Einbaulage Boden auf Dach
1. Fitting the riser section – Mounting position: Base section to roof
1. Zone de montage vertical – position base vers toit

- 1.20 Montage Flachteile und Dachblech
- 1.20 Fitting the panels and roof plate
- 1.20 Montage des pièces plates et du toit

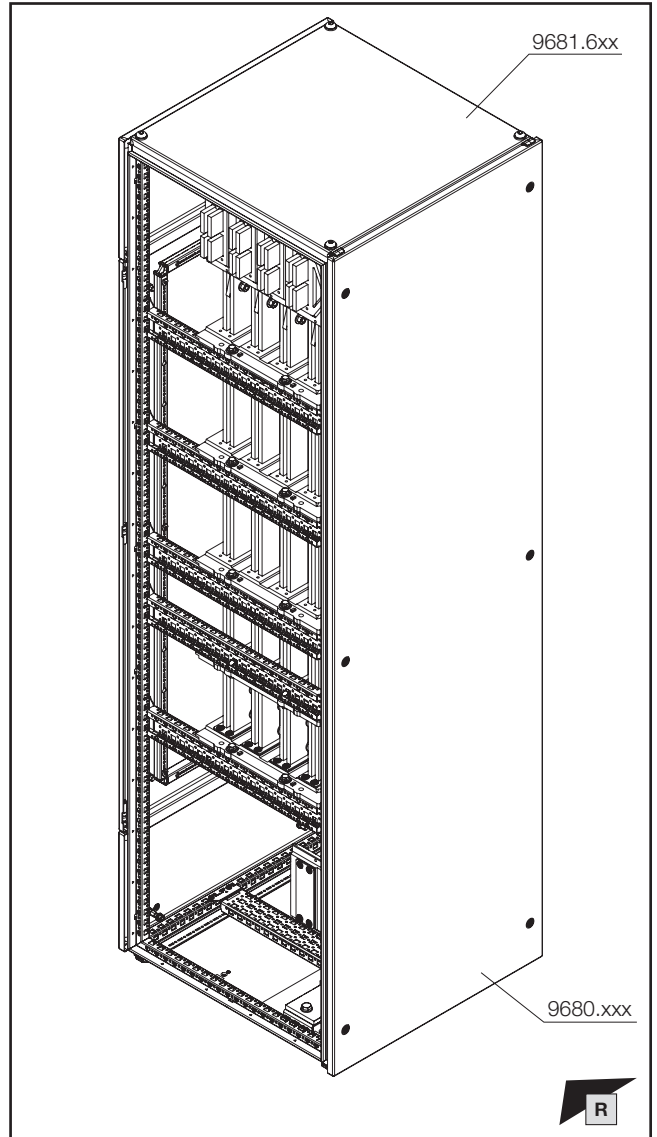
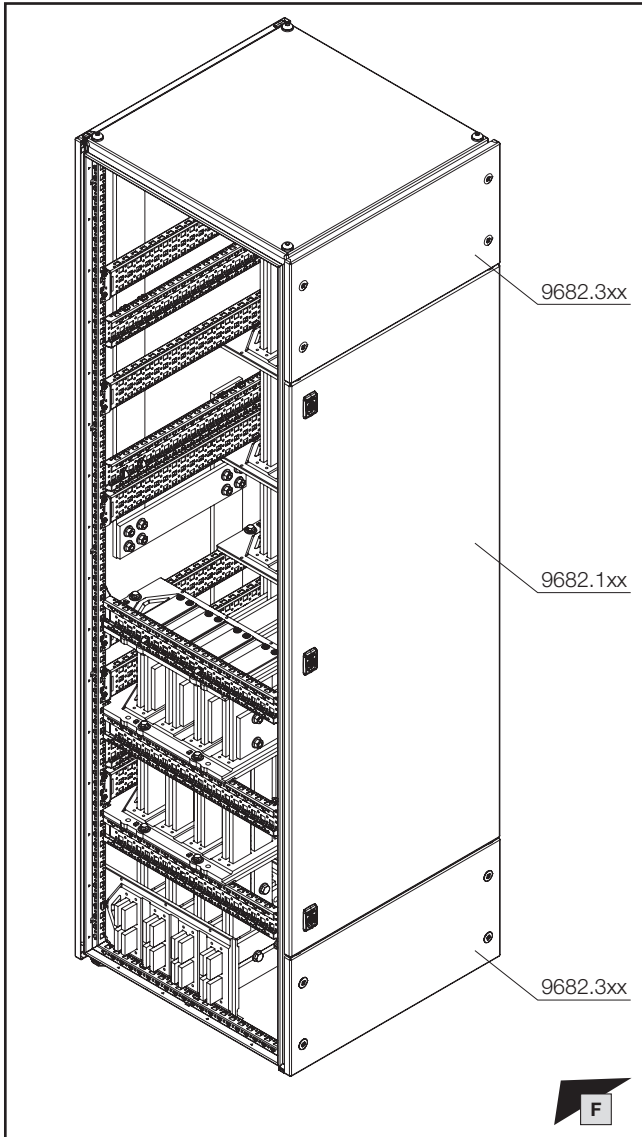

Hinweis / Note / Remarque

Beachten Sie für die abschließenden Arbeiten (Montage Flachteile, Frontgestaltung) je nach verwendetem Schrank die Beschreibungen in folgenden Anleitungen.

For the final work (fitting the panels, designing the front), please refer to the descriptions in the following instructions, depending on the enclosure used.

Pour les travaux finaux (montage des pièces plates, aménagement de la face avant), veuillez tenir compte, en fonction de l'armoire utilisée, des indications dans les notices suivantes.

Anreih-Schranksystem VX25
Enclosure baying system VX25
Armoires juxtaposables VX25

 **DE/EN/FR**

Modulare Frontgestaltung VX25
Modular front design VX25
Aménagement modulaire de la face avant VX25

 **DE/EN/FR**

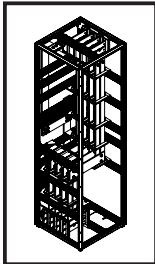

SW16/
SW17

2. Besonderheiten
2. Particular features
2. Caractéristiques particulières



- 2.1 Sammelschienensystem 2 x 50 x 10
- 2.1 Busbar system 2 x 50 x 10
- 2.1 Jeu de barres avec 2 barres de courant 50 x 10

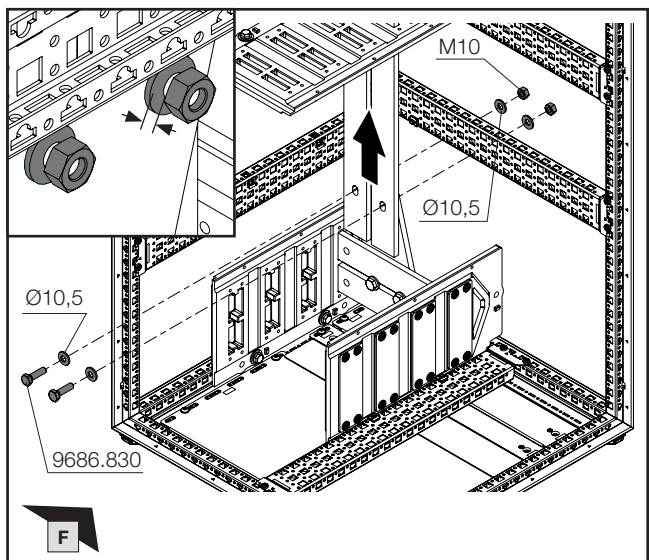
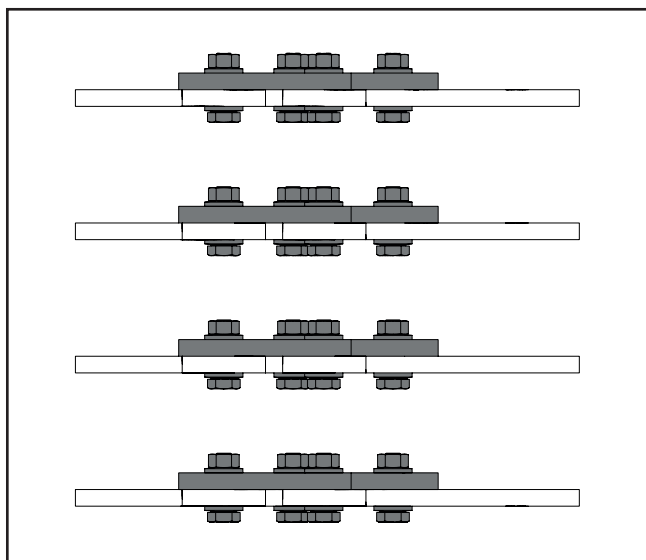
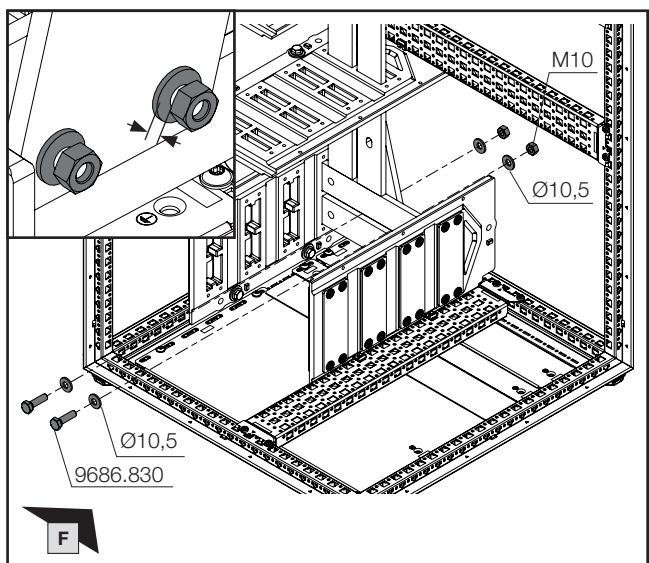
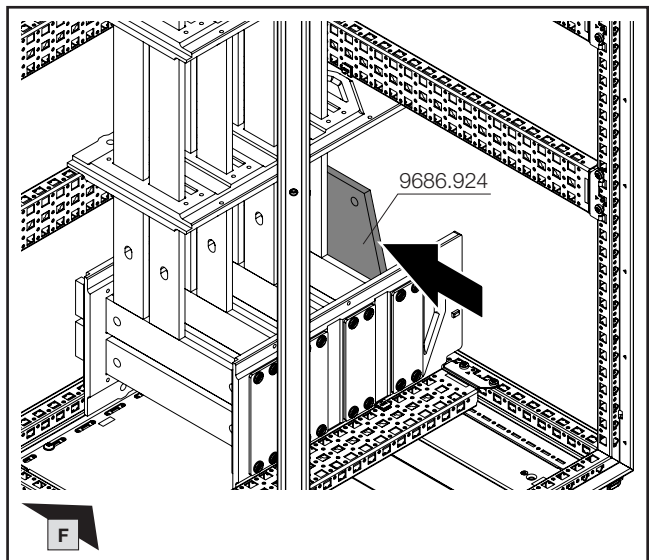
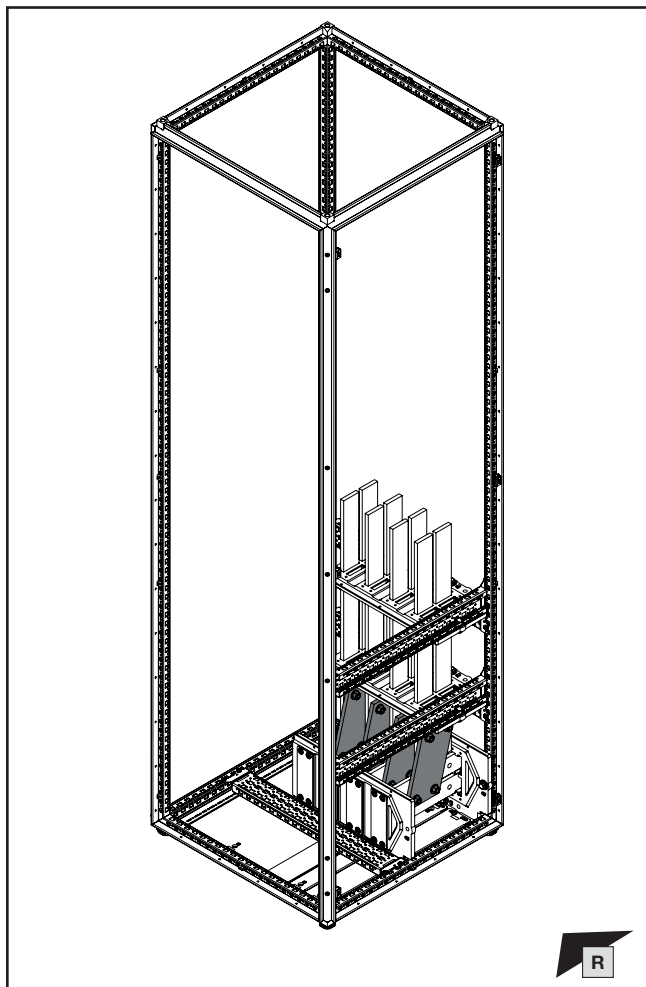

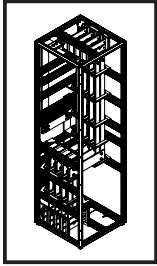

SW16/
SW17 

DE EN FR

2. Besonderheiten 2. Particular features 2. Caractéristiques particulières



- 2.1 Sammelschienensystem 2 x 50 x 10
- 2.1 Busbar system 2 x 50 x 10
- 2.1 Jeu de barres avec 2 barres de courant 50 x 10

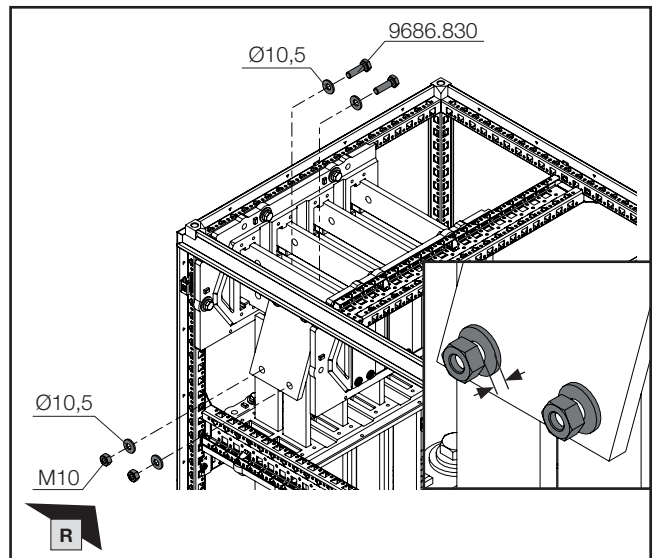
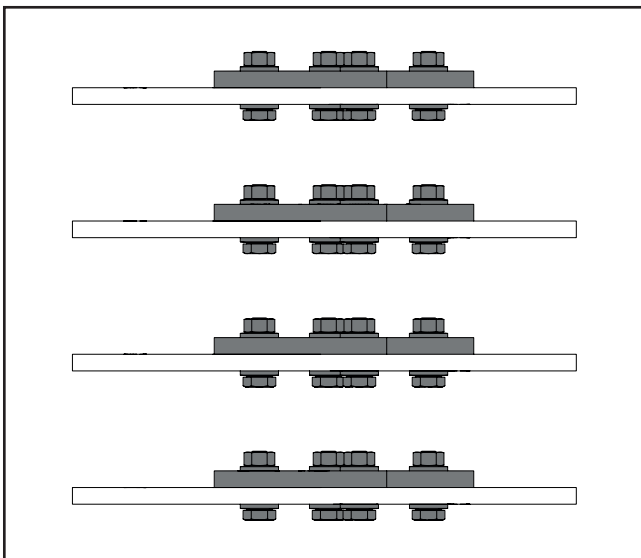
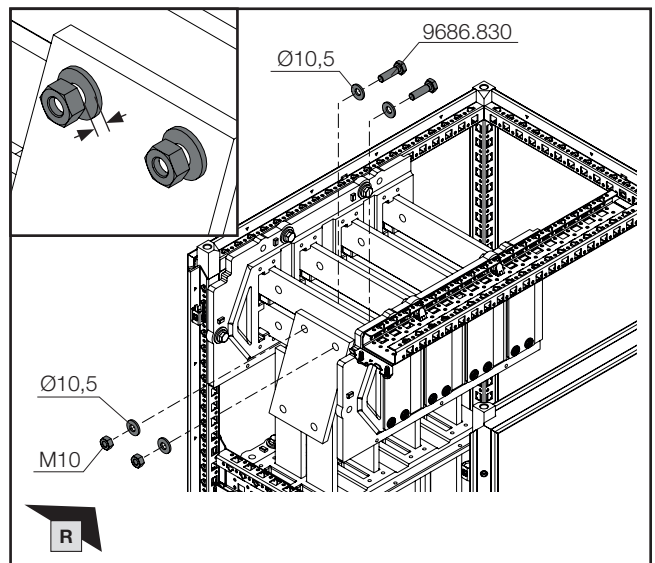
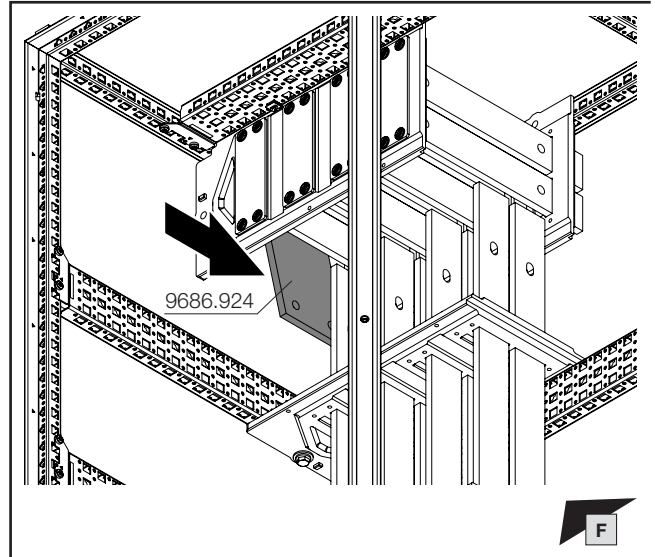
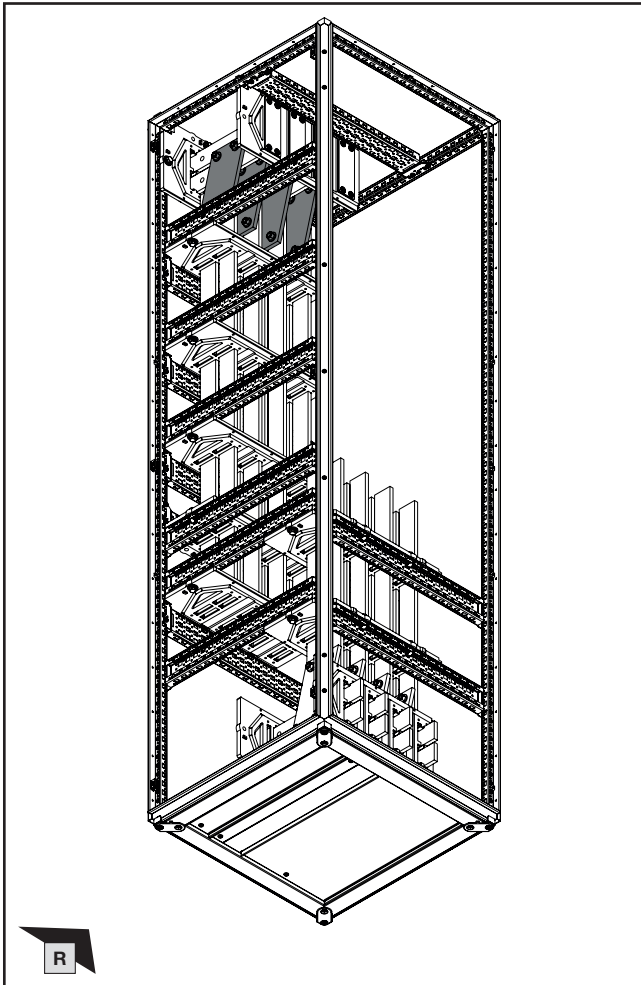

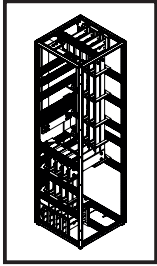

SW16/
SW17

DE EN FR

2. Besonderheiten 2. Particular features 2. Caractéristiques particulières



- 2.1 Sammelschienensystem 2 x 50 x 10
- 2.1 Busbar system 2 x 50 x 10
- 2.1 Jeu de barres avec 2 barres de courant 50 x 10

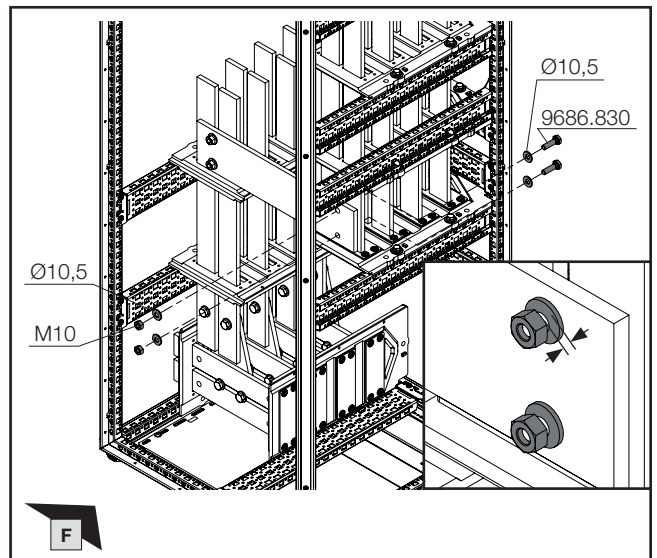
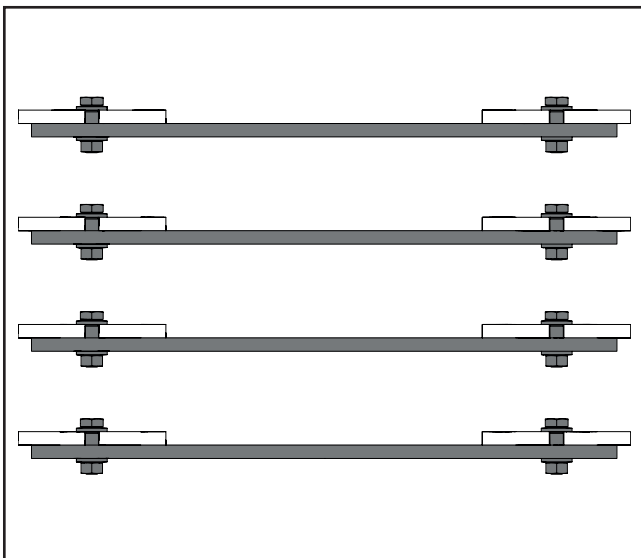
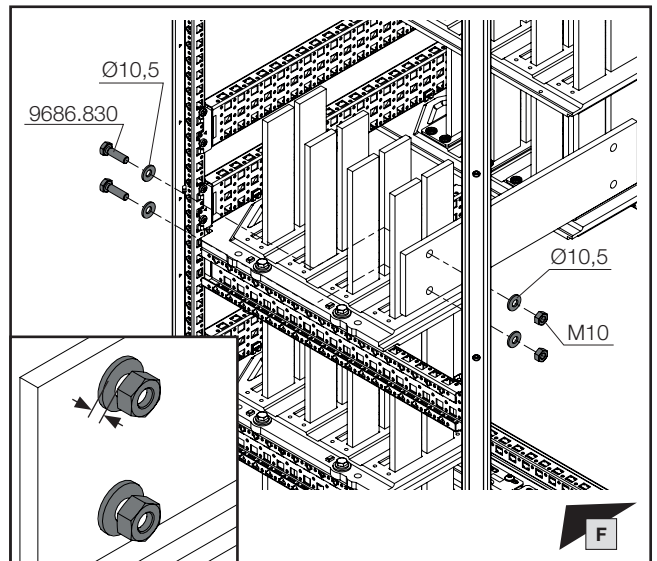
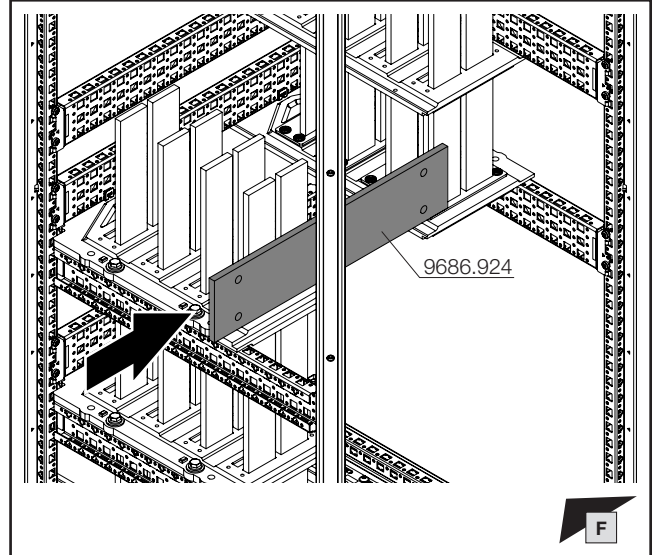
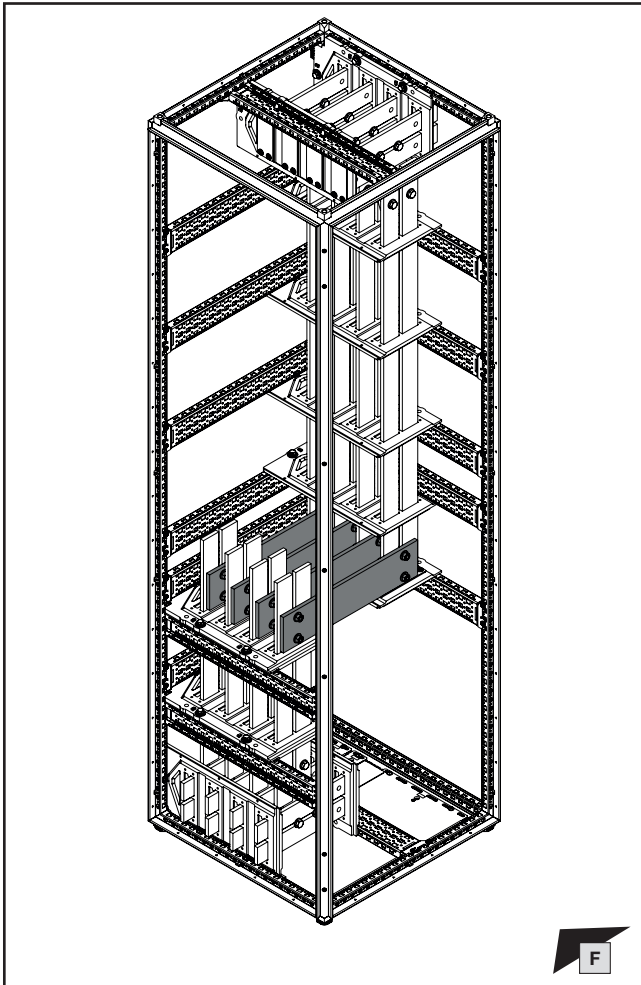

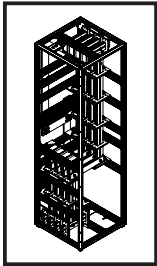

SW16/
SW17

2. Besonderheiten
2. Particular features
2. Caractéristiques particulières



- 2.2 Sammelschienensystem 4 x 30 x 10
- 2.2 Busbar system 4 x 30 x 10
- 2.2 Jeu de barres avec 4 barres de courant 30 x 10

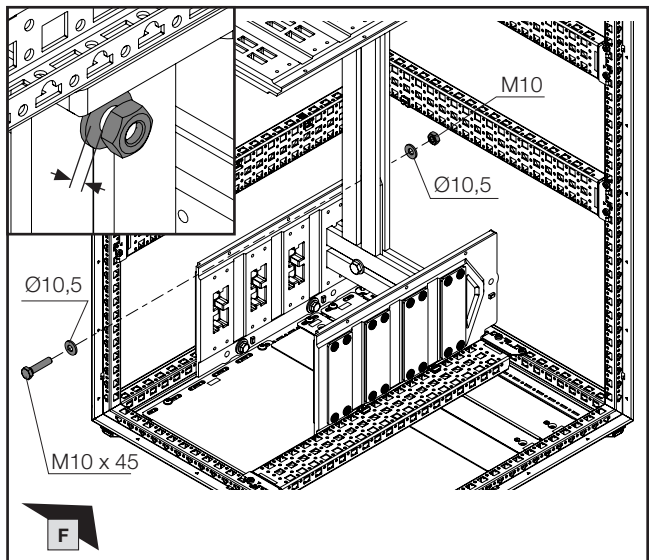
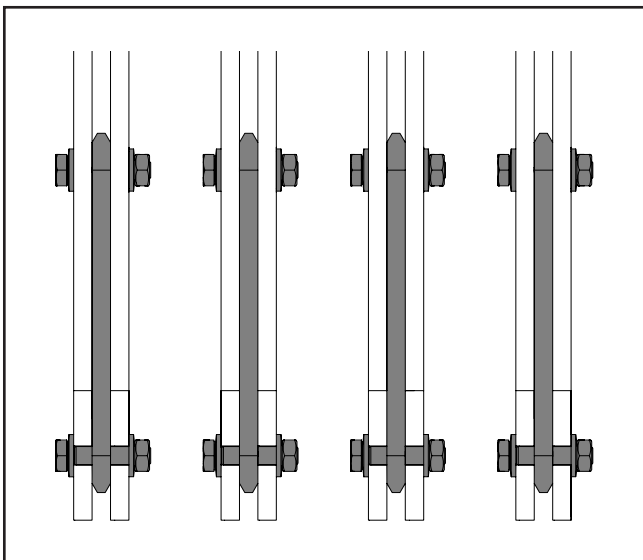
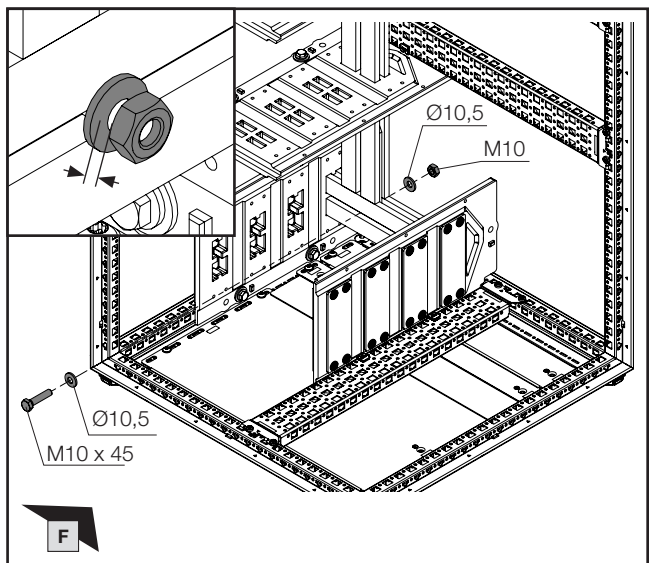
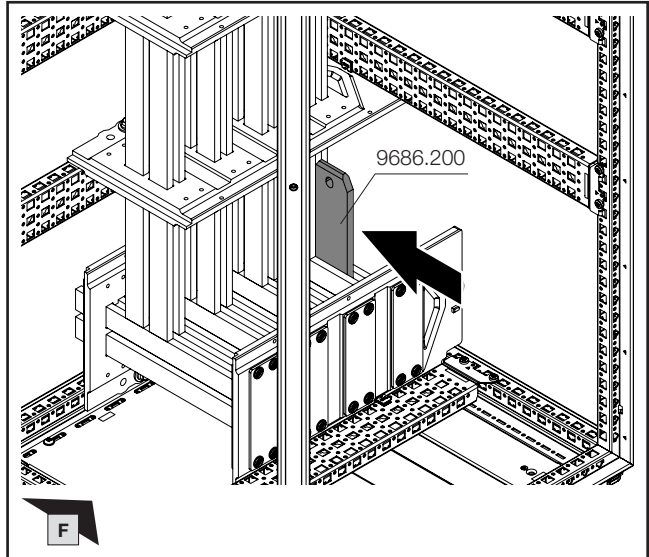
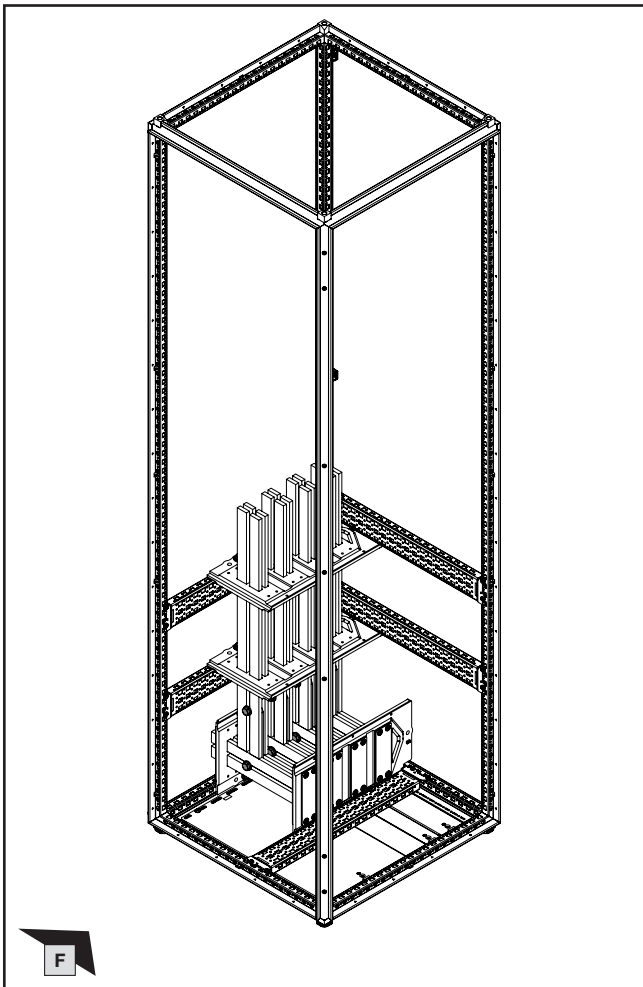

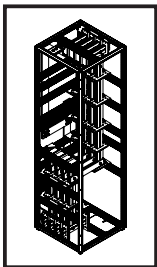

SW16/
SW17

2. Besonderheiten
2. Particular features
2. Caractéristiques particulières



- 2.2 Sammelschienensystem 4 x 30 x 10
- 2.2 Busbar system 4 x 30 x 10
- 2.2 Jeu de barres avec 4 barres de courant 30 x 10

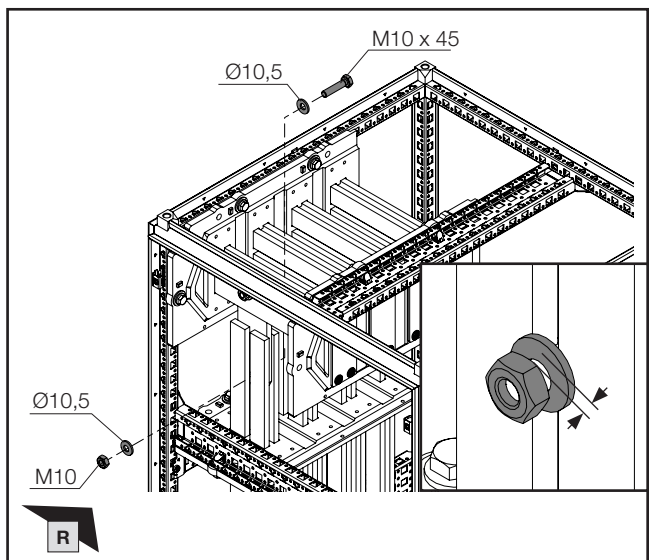
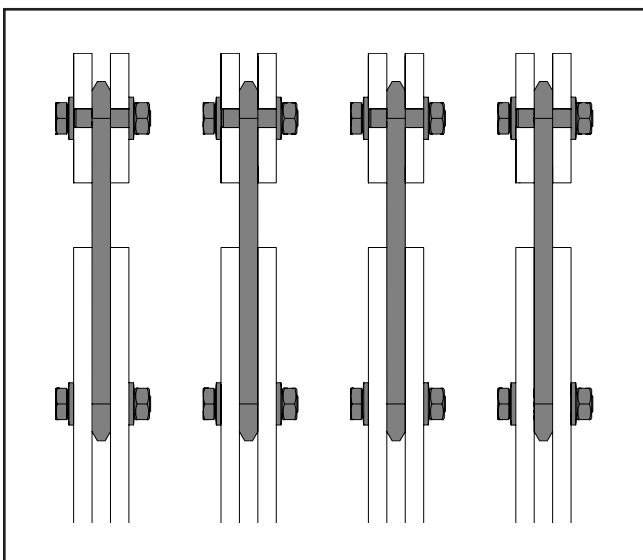
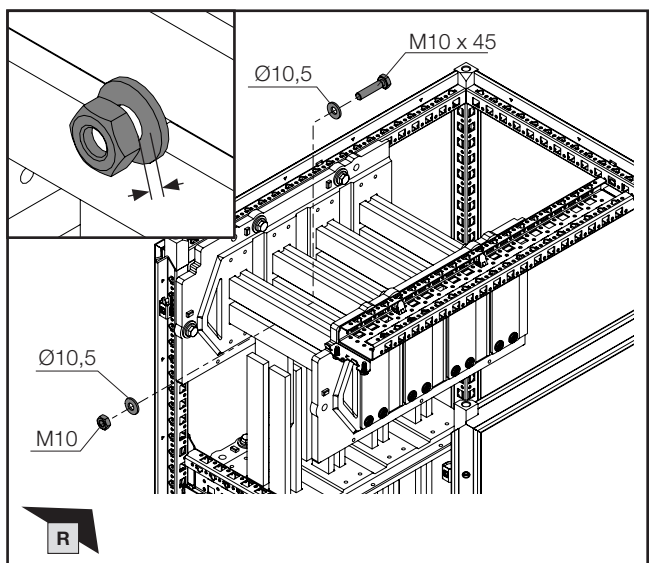
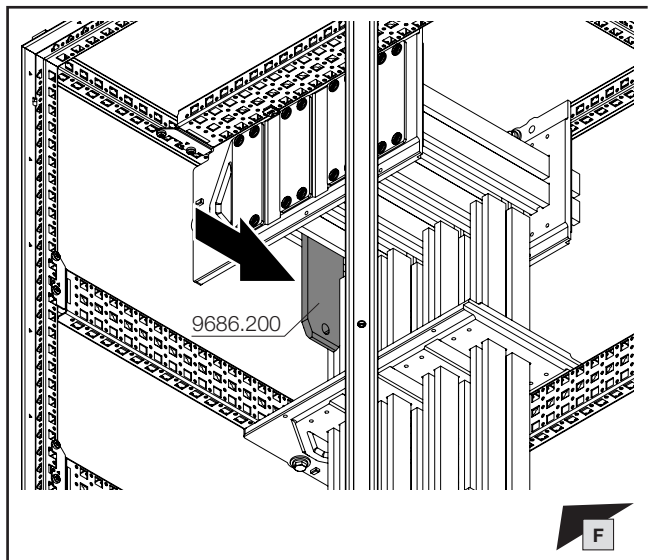
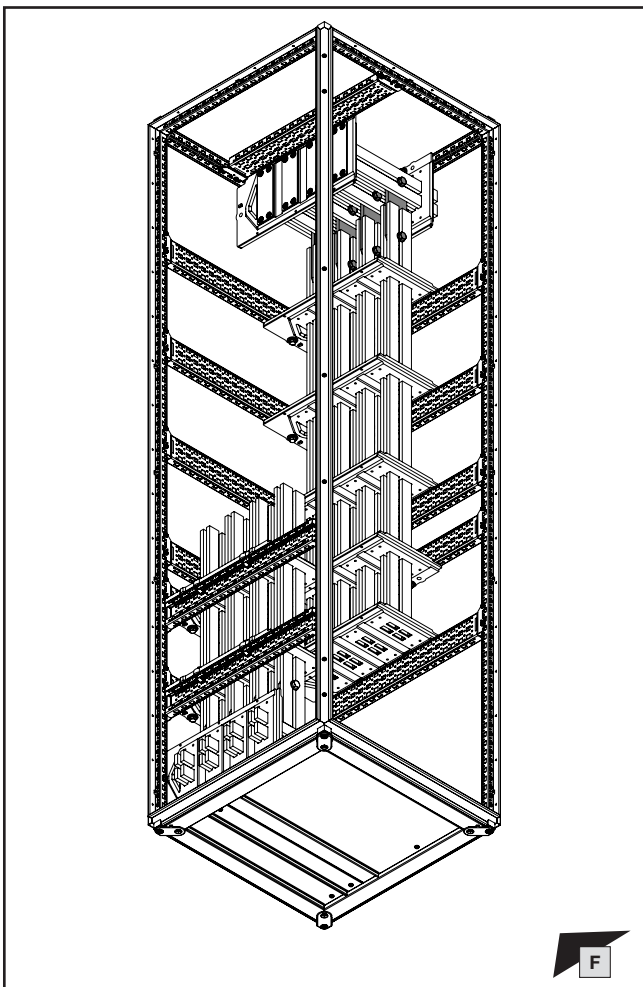

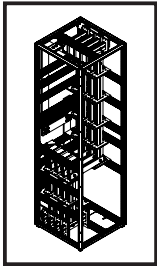

SW16/
SW17

2. Besonderheiten
2. Particular features
2. Caractéristiques particulières



- 2.2 Sammelschienensystem 4 x 30 x 10
- 2.2 Busbar system 4 x 30 x 10
- 2.2 Jeu de barres avec 4 barres de courant 30 x 10

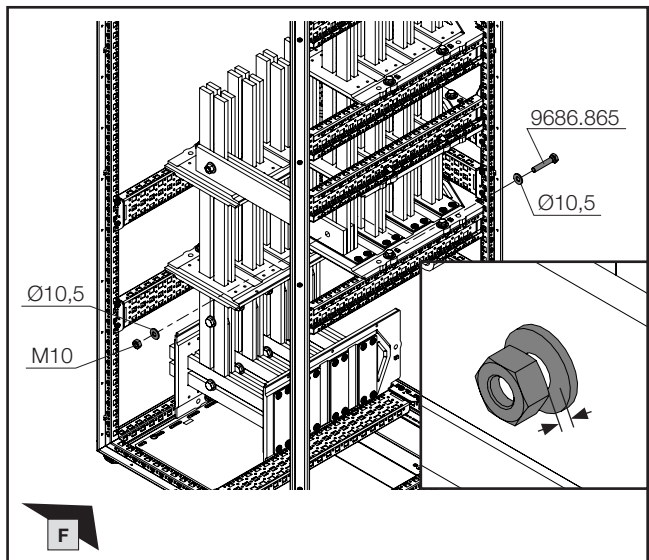
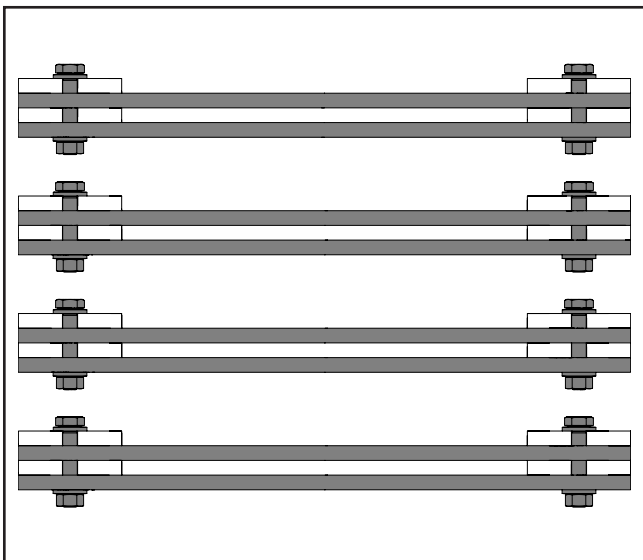
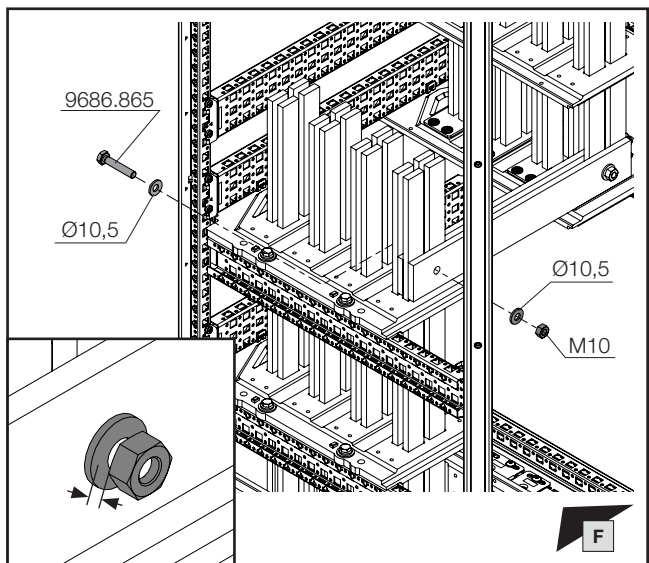
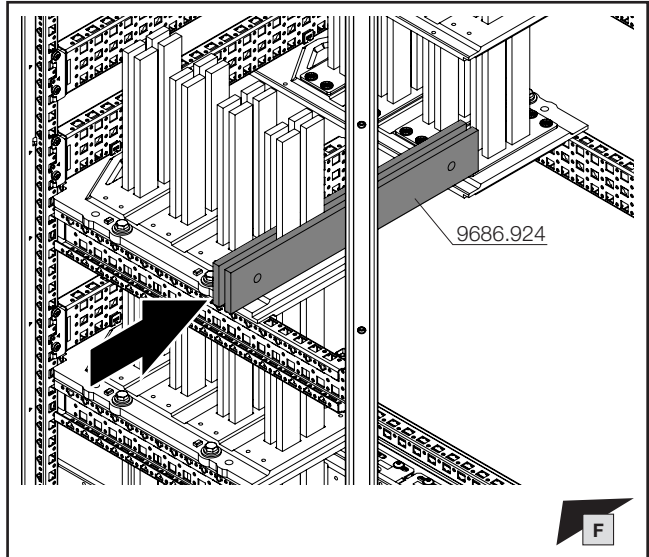
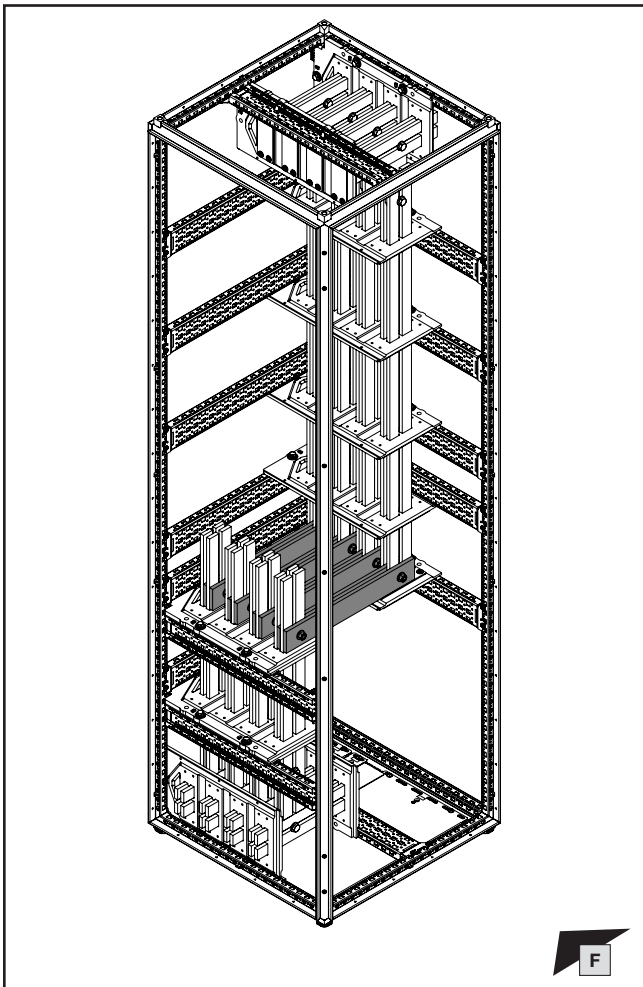

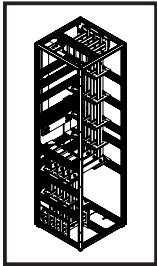

SW16/
SW17

2. Besonderheiten
2. Particular features
2. Caractéristiques particulières



- 2.3 Sammelschienensystem 2 x 30 x 10
- 2.3 Busbar system 2 x 30 x 10
- 2.3 Jeu de barres avec 2 barres de courant 30 x 10

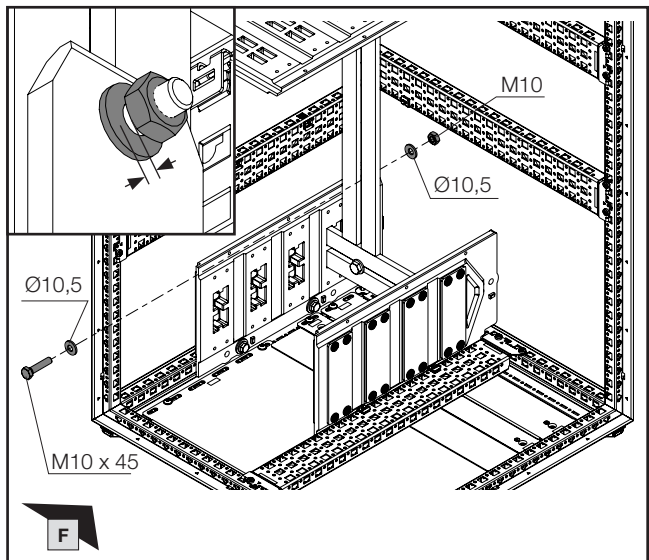
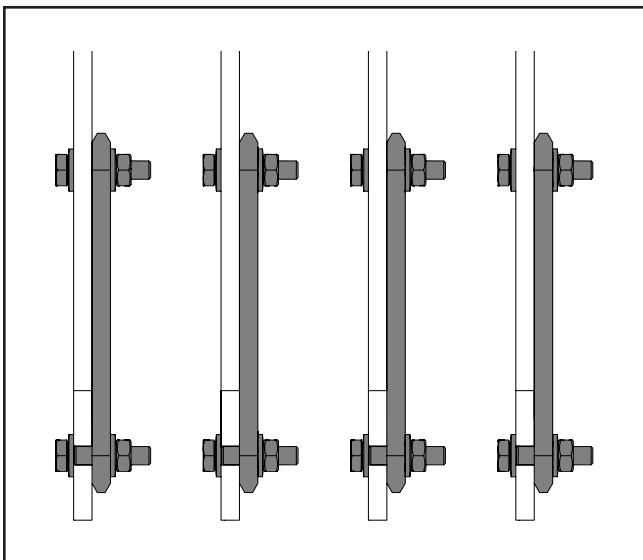
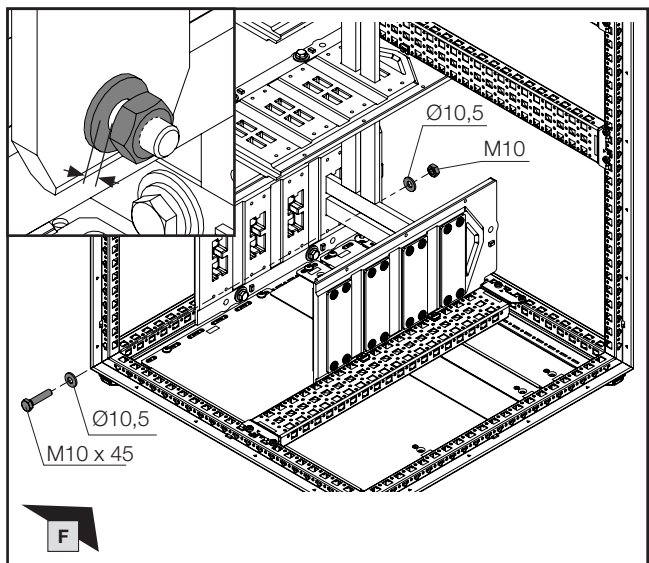
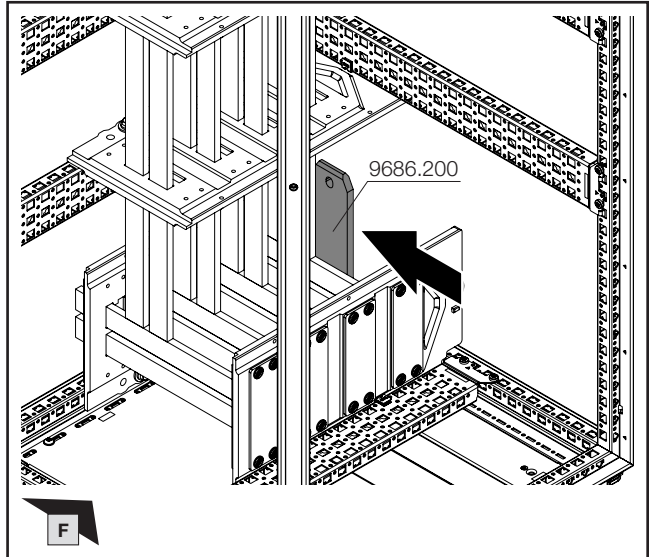
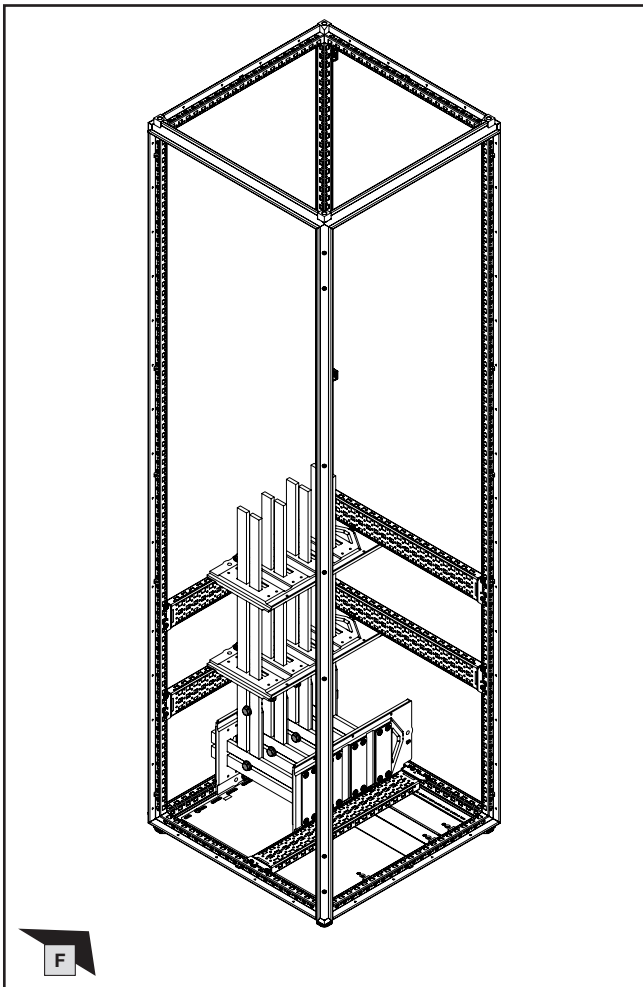

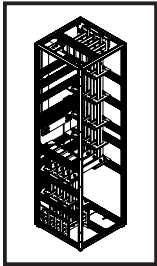

SW16/
SW17

DE EN FR

2. Besonderheiten

2. Particular features

2. Caractéristiques particulières



- 2.3 Sammelschienensystem 2 x 30 x 10
- 2.3 Busbar system 2 x 30 x 10
- 2.3 Jeu de barres avec 2 barres de courant 30 x 10

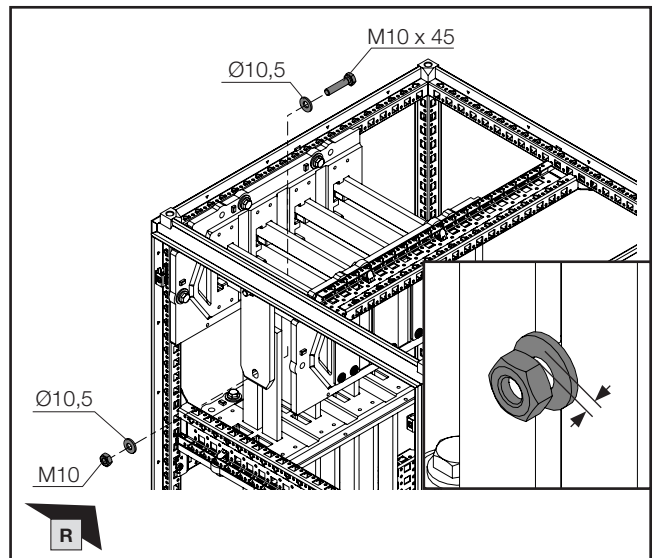
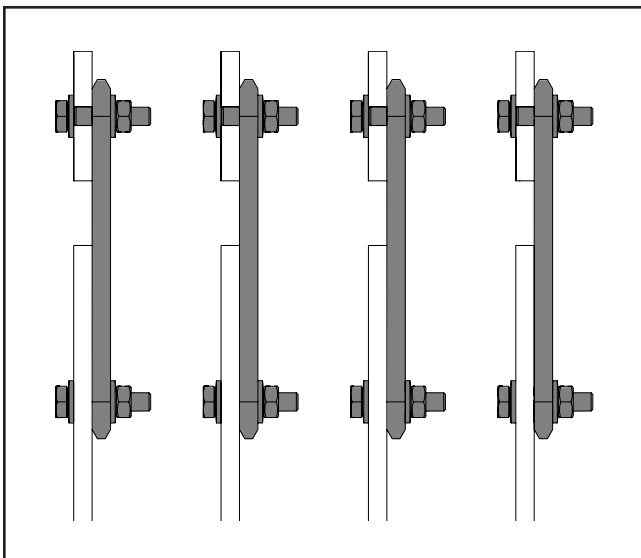
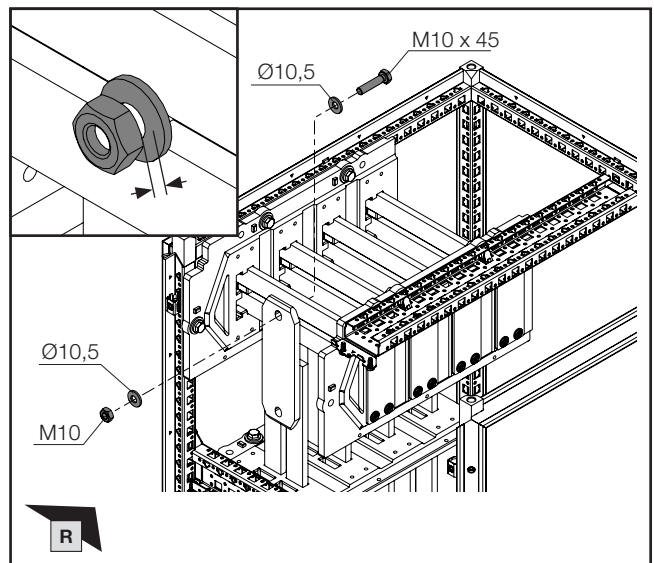
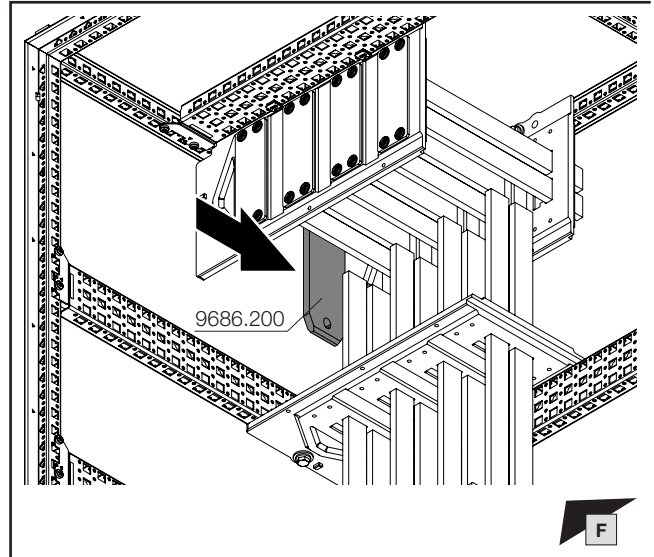
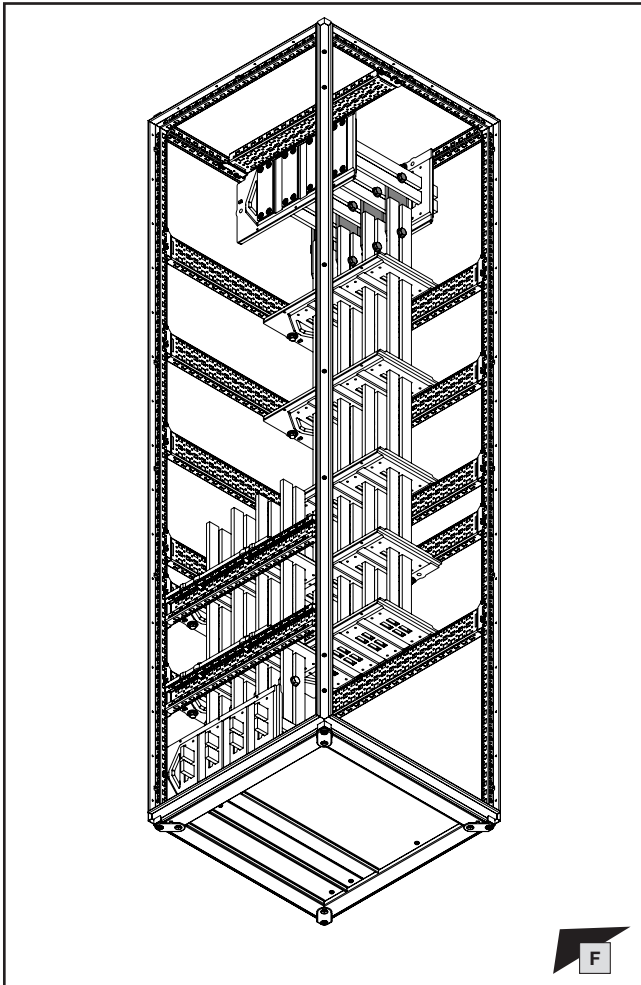

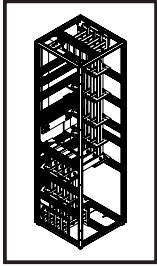

SW16/
SW17

DE EN FR

2. Besonderheiten 2. Particular features 2. Caractéristiques particulières



- 2.3 Sammelschienensystem 2 x 30 x 10
- 2.3 Busbar system 2 x 30 x 10
- 2.3 Jeu de barres avec 2 barres de courant 30 x 10

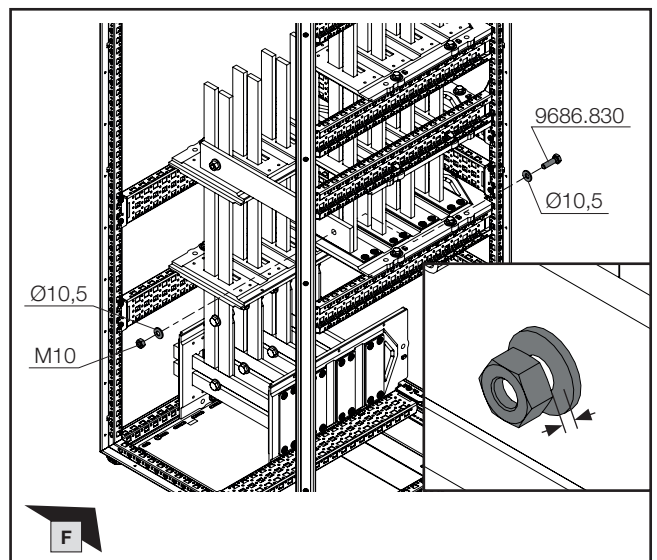
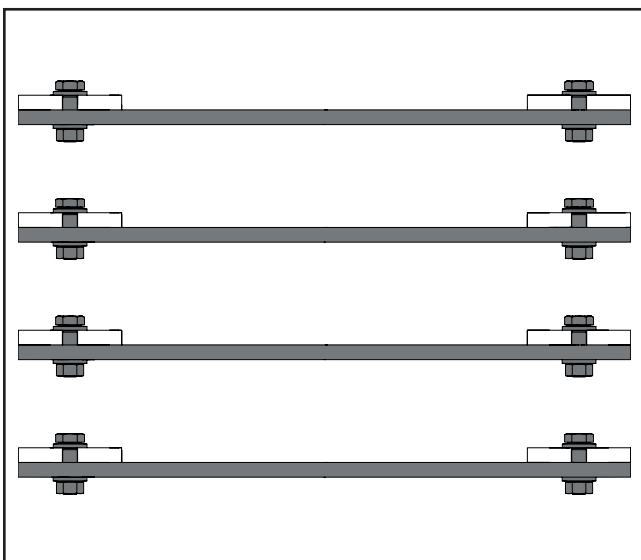
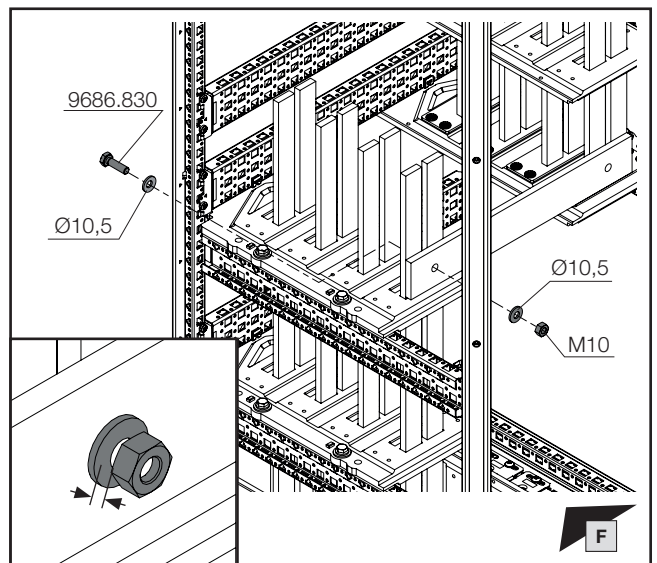
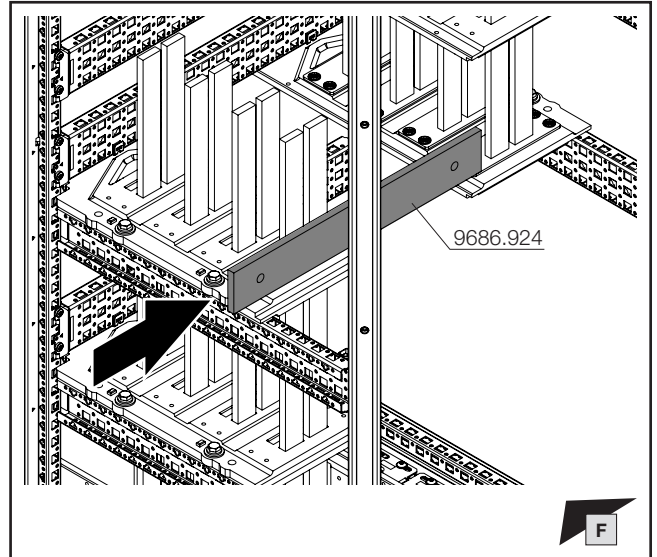
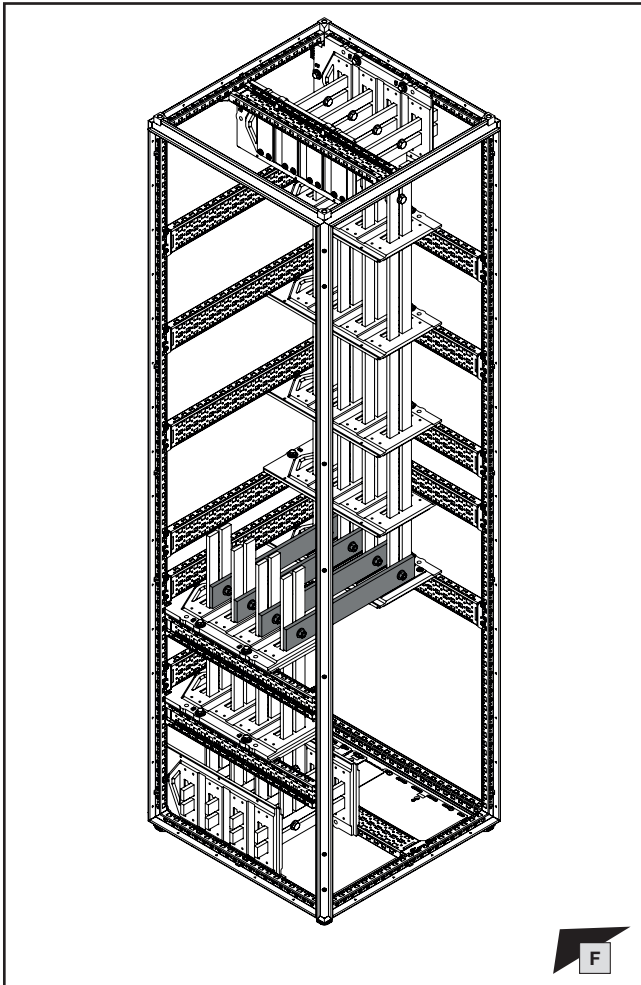

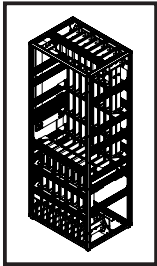

2. Besonderheiten
2. Particular features
2. Caractéristiques particulières

- 2.4 Hochführungsfeld 800 mm tief mit 2 x 4 x 50 x 10 Verteilungsbars
- 2.4 Riser section 800 mm deep with 2 x 4 x 50 x 10 distribution busbars
- 2.4 Zone de montage vertical 800 mm de profondeur avec jeux de barres de distribution 2 x 4 x 50 x 10

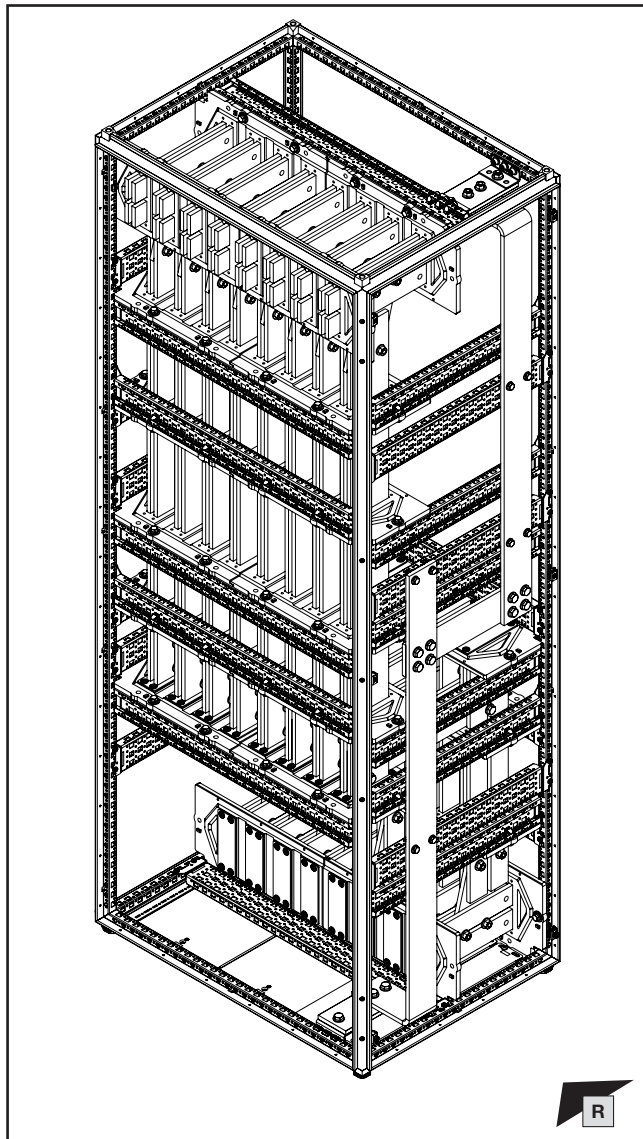
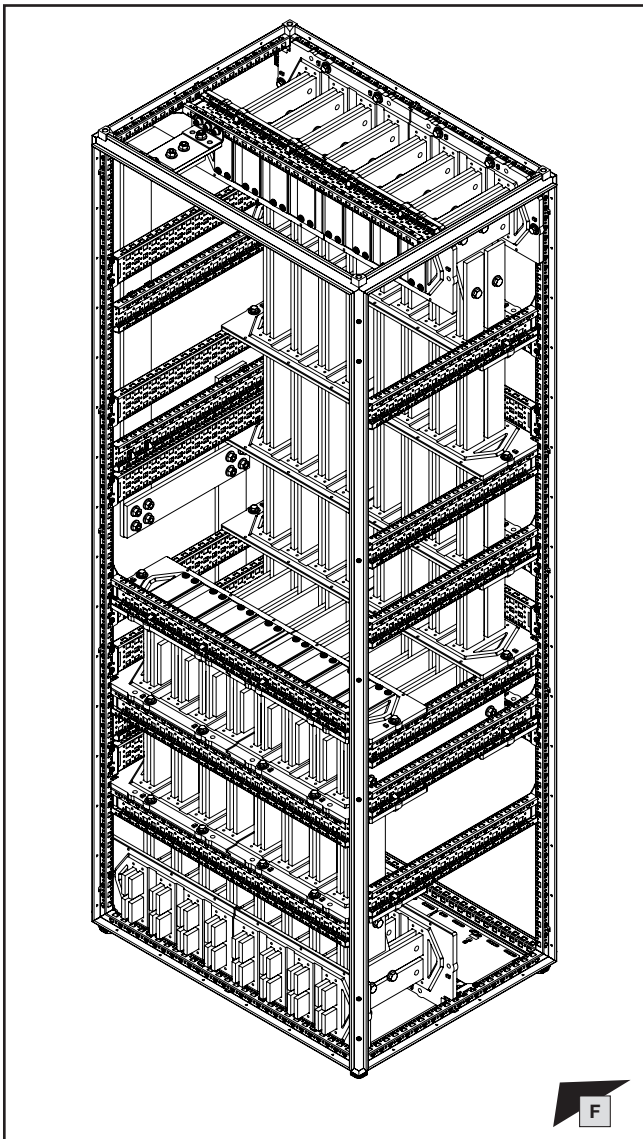

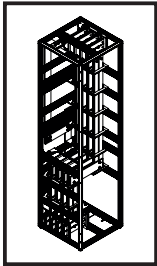

2. Besonderheiten
 2. Particular features
 2. Caractéristiques particulières

- 2.5 Hochführungsfeld 2200 mm hoch
- 2.5 Riser section 2200 mm high
- 2.5 Zone de montage vertical 2200 mm de hauteur

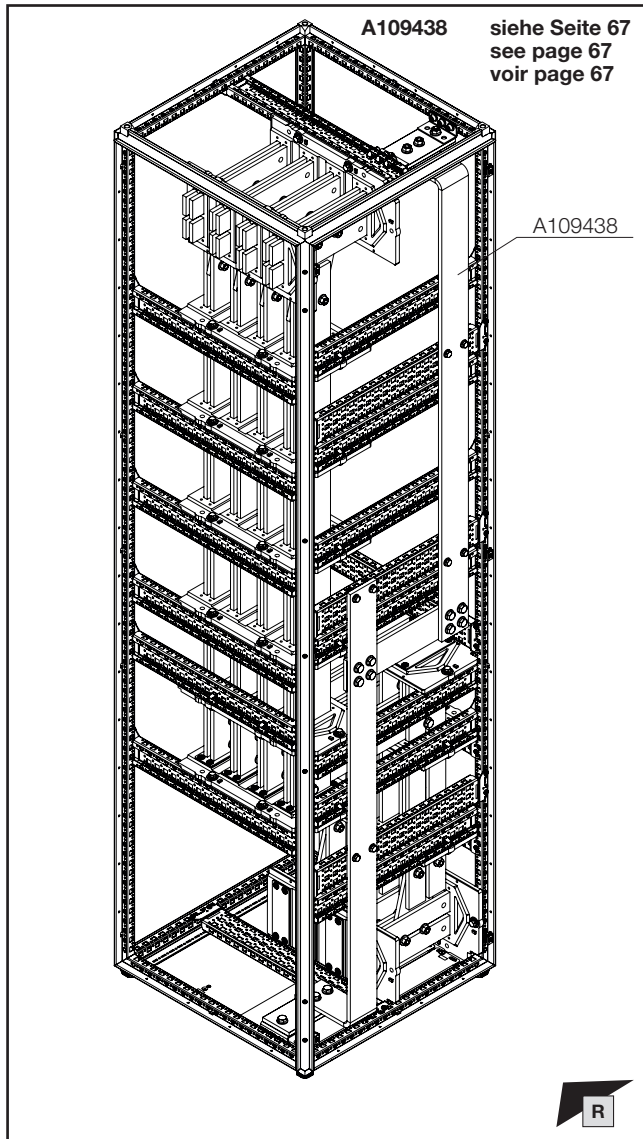
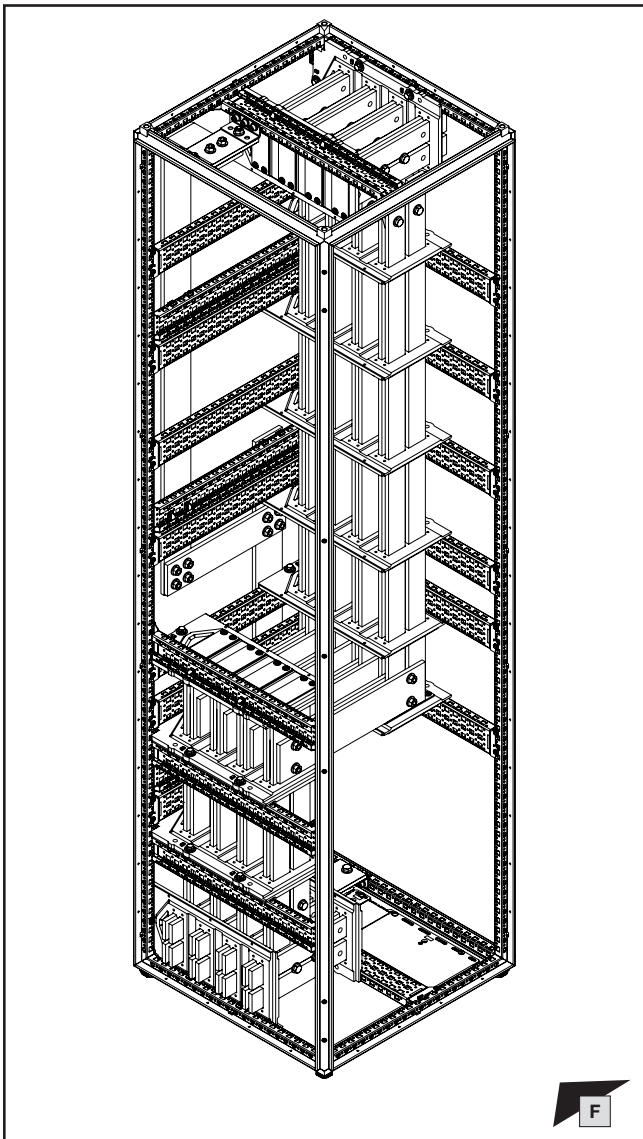

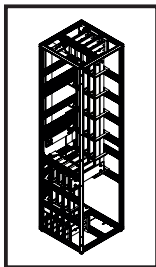

2. Besonderheiten
 2. Particular features
 2. Caractéristiques particulières

- 2.5 Hochführungsfeld 2200 mm hoch
- 2.5 Riser section 2200 mm high
- 2.5 Zone de montage vertical 2200 mm de hauteur

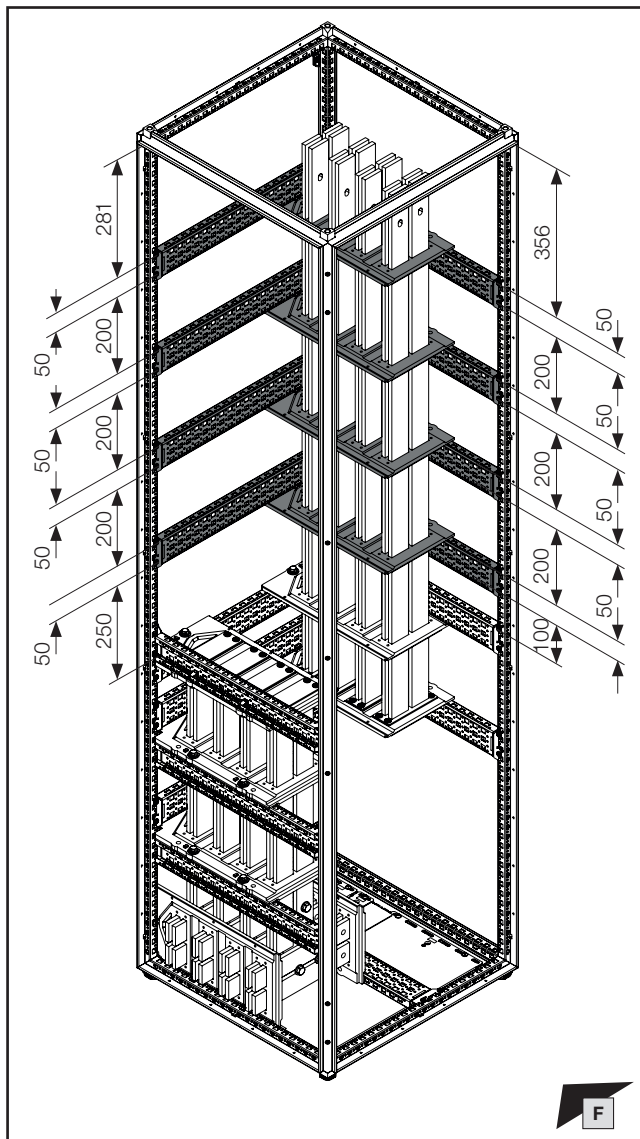
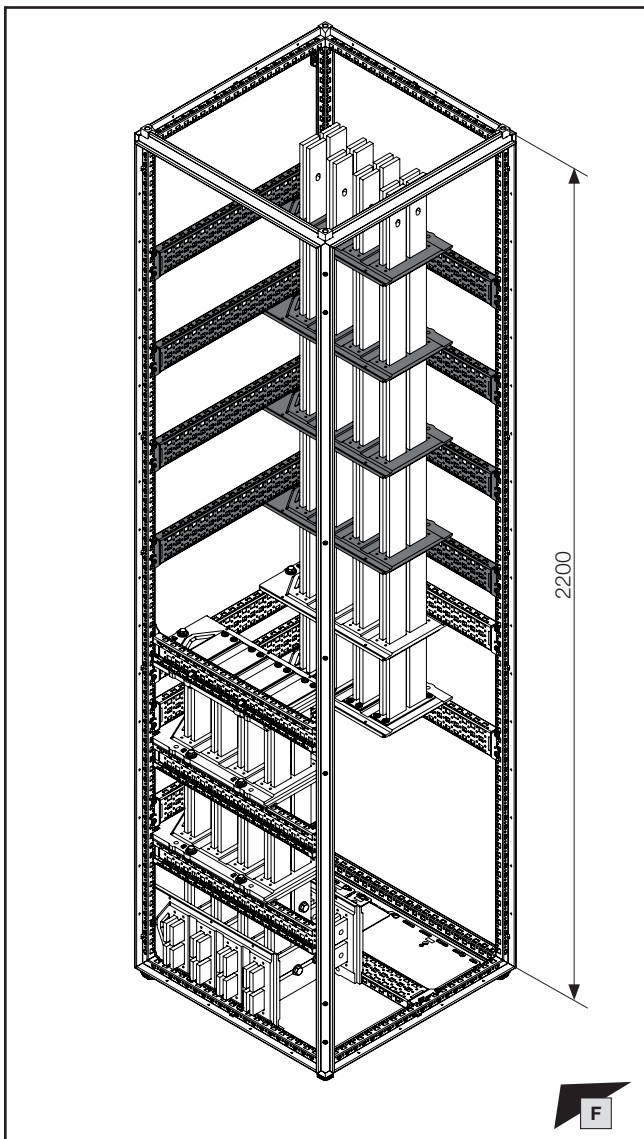

Hinweis / Note / Remarque

Bei erschwelter Montage Befestigungsschrauben der Sammelschienenhalter lösen und zum Abschluss des Montageschritts anziehen.

If fitting is difficult, loosen the assembly screws of the busbar supports and tighten them at the end of this step.

En cas de difficulté de montage, desserrer les vis de fixation des supports de jeux de barres et les resserrer en fin de montage.

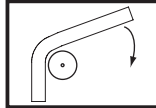
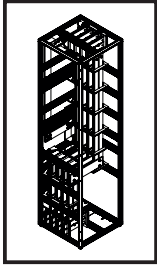

2. Besonderheiten

2. Particular features

2. Caractéristiques particulières

- 2.5 Hochführungsfeld 2200 mm hoch
- 2.5 Riser section 2200 mm high
- 2.5 Zone de montage vertical 2200 mm de hauteur

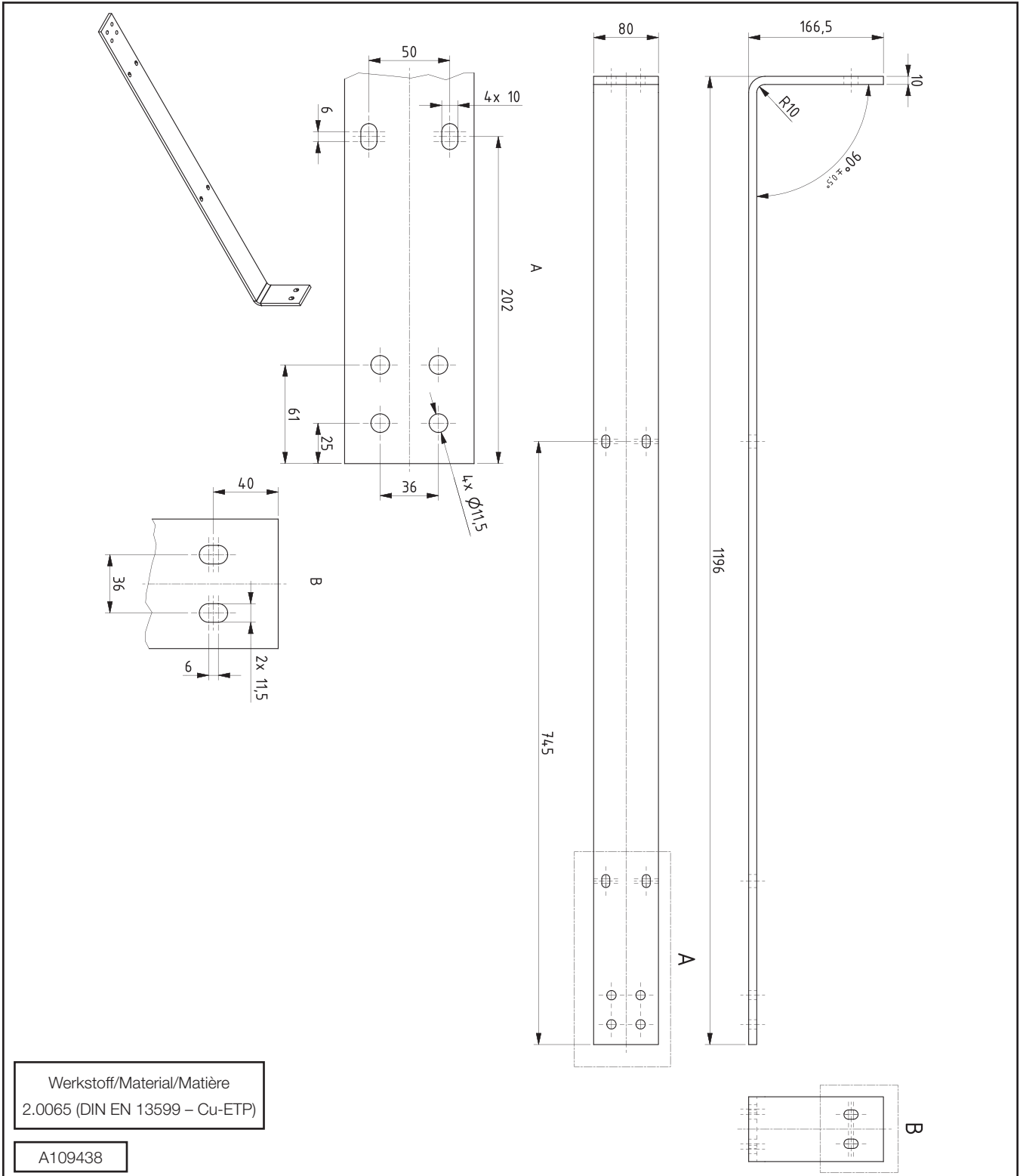

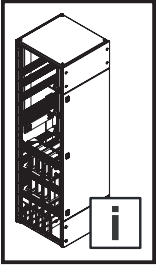

Artikelverzeichnis
List of model numbers
Liste des références

Best.-Nr. Model No. Référence	Kapitel Chapter Chapitre
4165.500	1.3
	1.5
	1.9
	1.11
	1.12
	1.15
	1.17
	1.18
8617.130	1.3
	1.4
	1.8
	1.11
	1.12
	1.15
	1.17
	1.18
8617.140	1.3
	1.4
	1.8
	1.11
	1.12
	1.15
	1.17
	1.18
9680.606	1.2
9680.608	1.2
9680.626	1.2
9680.628	1.2
9681.666	1.20
9681.668	1.20
9682.174	1.20
9682.176	1.20
9682.326	1.20
9682.346	1.20
9682.356	1.20
9686.000	1.3
	1.12
9686.010	1.3
	1.5
	1.9
	1.11
	1.12
	1.15
9686.030	1.3
	1.12
9686.040	1.3
	1.5
	1.9
	1.11
	1.12
	1.15
9686.080	1.3
	1.9
	1.12
	1.15
9686.200	2.2
	2.3
9686.350	1.17
	1.18
9686.830	1.17
	1.18
	1.19
	2.1
	2.3

Best.-Nr. Model No. Référence	Kapitel Chapter Chapitre
9686.845	1.7
	1.13
9686.865	1.14
	2.2
9686.924	1.3
	1.6
	1.7
	1.10
	1.12
	1.13
	1.14
	2.1
2.2	
2.3	

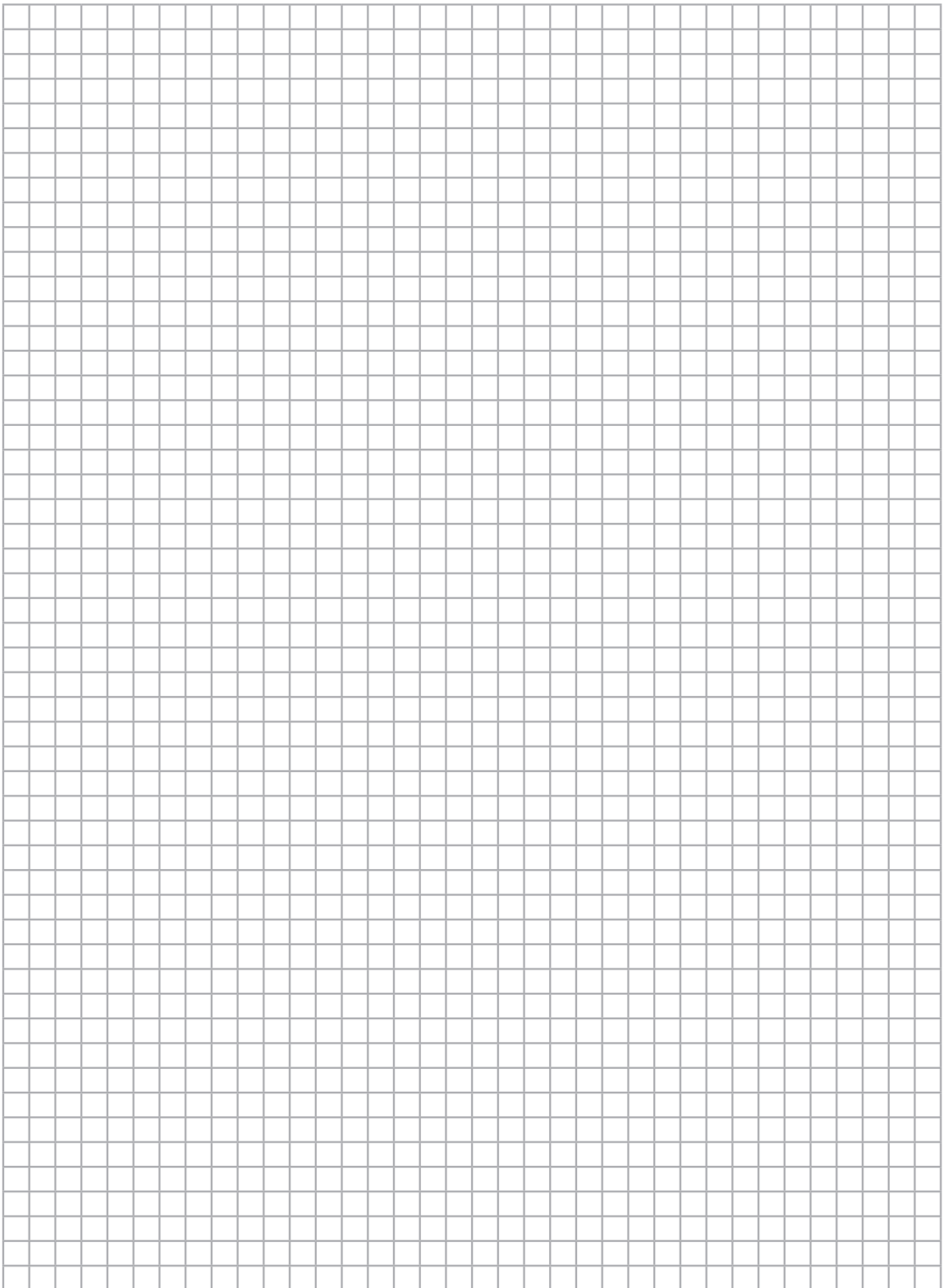

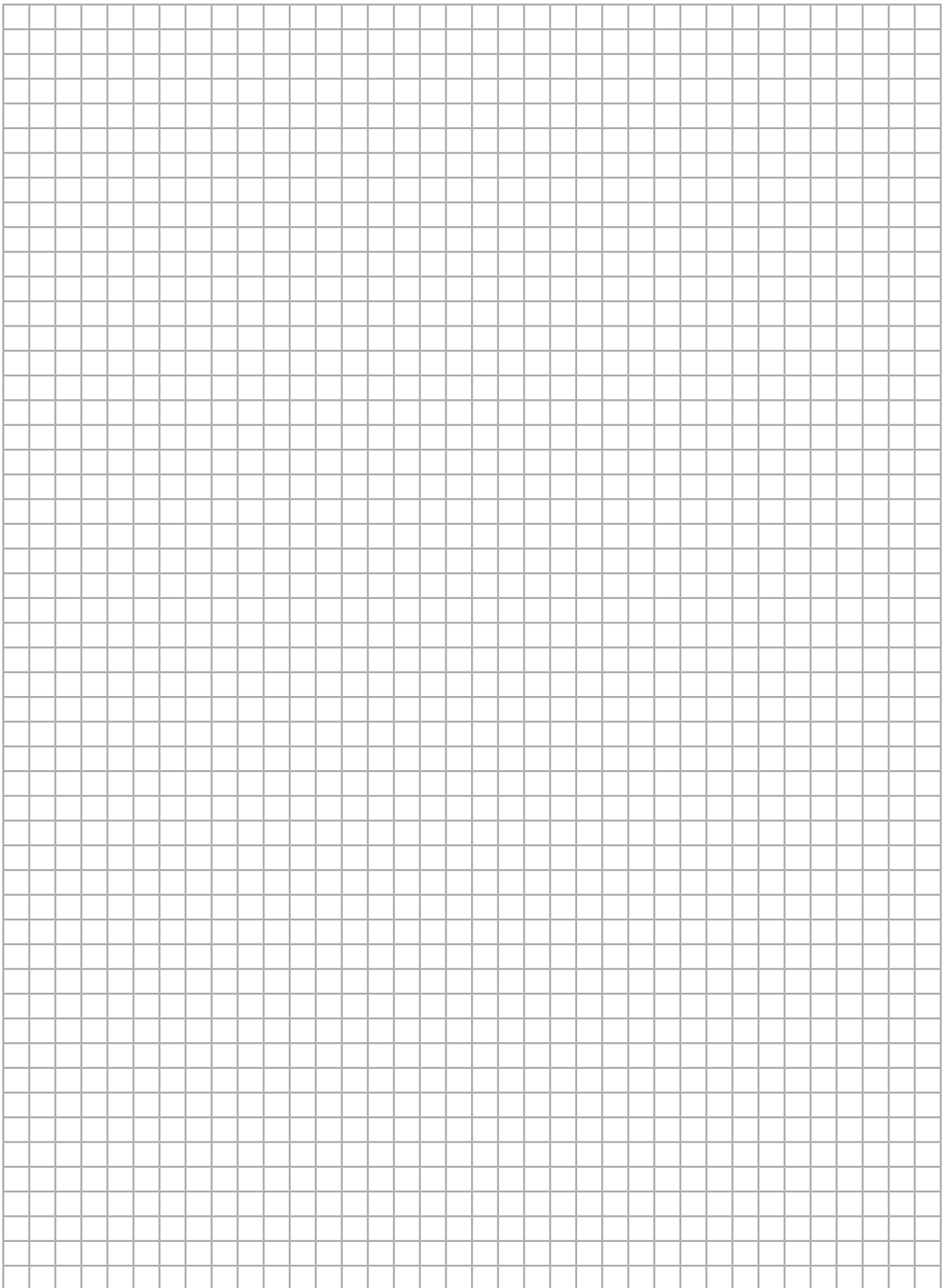

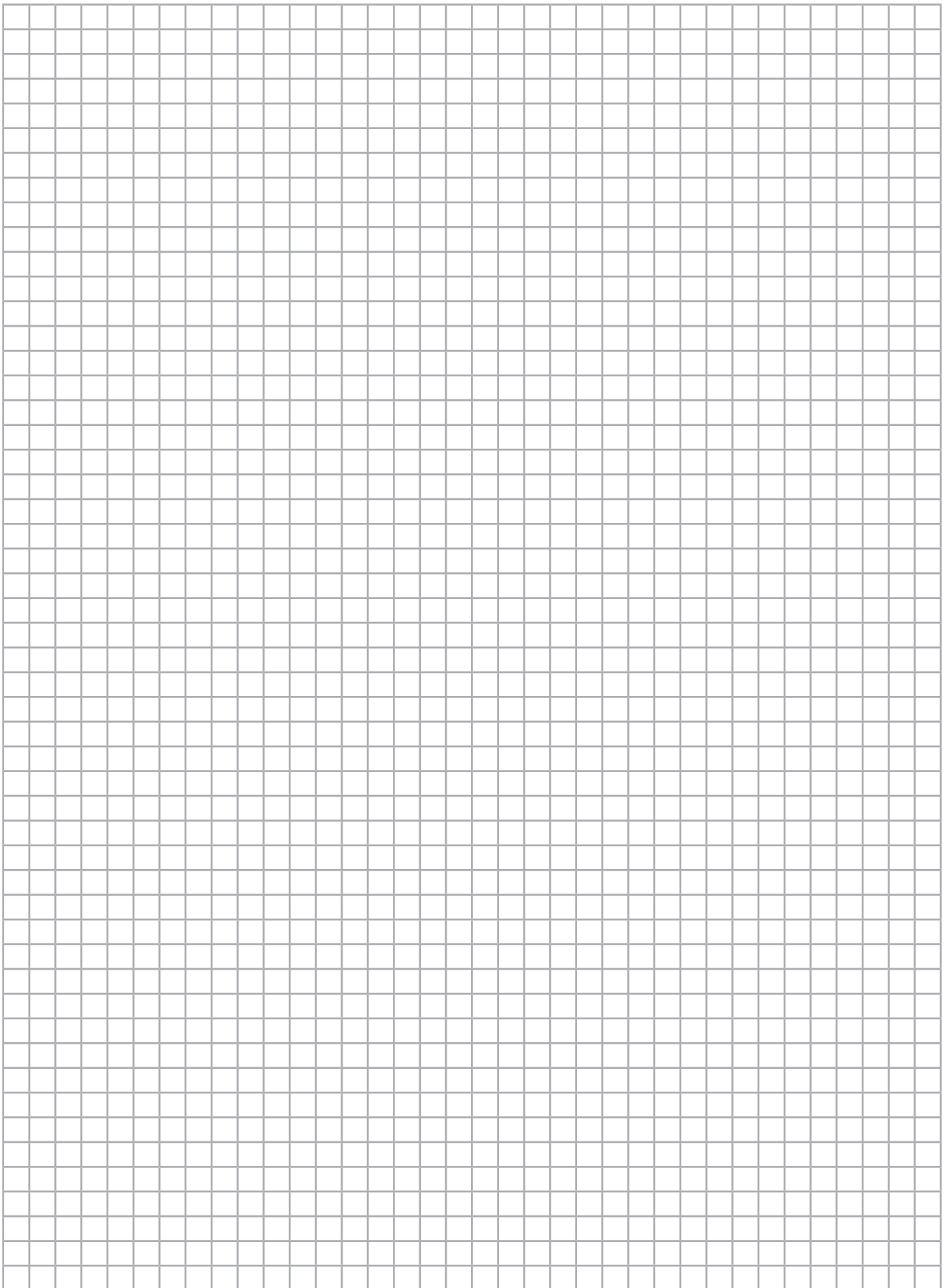

Rittal – The System.

Faster – better – everywhere.

- Enclosures
- Power Distribution
- Climate Control
- IT Infrastructure
- Software & Services

You can find the contact details of all Rittal companies throughout the world here.



www.rittal.com/contact

RITTAL GmbH & Co. KG
Auf dem Stuetzelberg · 35745 Herborn · Germany
Phone +49 2772 505-0
E-mail: info@rittal.de · www.rittal.com

08.2025/D-0000-00003435-01

ENCLOSURES

POWER DISTRIBUTION

CLIMATE CONTROL

IT INFRASTRUCTURE

SOFTWARE & SERVICES

FRIEDHELM LOH GROUP

