

Rittal – The System.

Faster – better – everywhere.



**Hochführungsfeld Boden-/
Rückbereich (Kapitel A.33)**

**Riser section, base area
(chapter A.33)**

**Zone d'installation verticale dans
la base (chapitre A.33)**

Anhang VX25 Ri4Power – Montageanleitung

Appendix VX25 Ri4Power – Assembly instructions

Annexe VX25 Ri4Power – Notice de montage

ENCLOSURES

POWER DISTRIBUTION

CLIMATE CONTROL

IT INFRASTRUCTURE

SOFTWARE & SERVICES

FRIEDHELM LOH GROUP



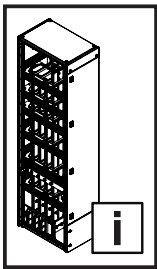

Inhaltsverzeichnis
Contents
Sommaire

DE

1. Montage Hochführungsfeld – Einbaulage Boden auf Rücken Mitte 6

1.1 Hochführungsfeld 600 mm oder 800 mm tief (4 x 50 x 10) – Hauptsammelschienensystem als 3-poliges System 6

1.2 Vorbereitung Modulschrank 7

1.3 Montage untere System-Chassis 8

1.4 Montage untere Sammelschienenhalter vertikal 11

1.5 Montage des unteren Hauptschienen-systems 14

1.6 Einbringung vertikale Verteilsammelschienen 18

1.7 Anbindung vertikales Verteilsammelschienen-system 20

1.8 Montage obere System-Chassis und Sammelschienenhalter 23

1.9 Montage des PE-/PEN-Sammelschienen-systems 30

1.10 Montage des N-Sammelschienen-systems 31

1.11 Montage des vertikalen Hauptschienen-systems 36

1.12 Montage der Anreihverbinder vertikales Hauptschienen-system 38

1.13 Montage des Stabilisators 39

1.14 Anziehen der Schrauben 43

2. Montage Beispielvariante Rückbereich Mitte – Sammelschienensystem N und PE 45

2.1 Beispielvariante Rückbereich Mitte – leeres Feld 45

2.2 Montage PE-/PEN-Sammelschienen-system 46

2.3 Montage des N-Sammelschienen-systems 52

2.4 Montage des rückwärtigen Hauptschienen-systems 54

3. Verbindung Hochführungsfeld und Beispielvariante Rückbereich Mitte 56

3.1 Verbindung des Hochführungsfelds und der Beispielvariante Rückbereich Mitte 56

3.2 Zusammenfügen der Schaltanlagenfelder – Montage der Anreihverbinder 57

3.3 Verschrauben der Längsverbinder 60

3.4 Montage Anschlusswinkel N 62

4. Modulare Frontgestaltung 65

4.1 Montage Flachteile und Dachblech 65

5. Besonderheit Sammelschienen-system 2 x 50 x 10 66

5.1 Montage des N-Sammelschienen-systems 66

5.2 Montage des vertikalen Hauptschienen-systems und der Anreihverbinder 67

5.3 Verbindung Hochführungsfeld und Feld Rückbereich 69

6. Besonderheit Hauptsammelschienen-system als 4-poliges System 70

6.1 Montage des Stabilisators 70

6.2 Montage des N-Sammelschienen-systems 71

7. Besonderheit 800 mm Schranktiefe (Übersicht) 72

8. Besonderheit Ausschnitt Form 2b Artikelverzeichnis 73 74

EN

1. Fitting the riser section – Mounting position: Base section via rear section in the centre 6

1.1 Riser section 600 mm or 800 mm deep (4 x 50 x 10) – Main busbar system as a 3-pole system 6

1.2 Preparing the modular enclosure 7

1.3 Fitting the lower punched sections with mounting flanges 8

1.4 Fitting the lower busbar supports, vertical 11

1.5 Fitting the lower main busbar system 14

1.6 Incorporating the vertical distribution busbars 18

1.7 Connecting the vertical multi-terminal busbar system 20

1.8 Fitting the upper punched sections with mounting flanges and busbar supports 23

1.9 Fitting the PE/PEN busbar system 30

1.10 Fitting the N busbar system 31

1.11 Fitting the vertical main busbar system 36

1.12 Fitting the baying connectors for the vertical main busbar system 38

1.13 Fitting the stabiliser 39

1.14 Tightening the screws 43

2. Fitting for a variant example – Rear area in the centre, busbar system N and PE 45

2.1 Variant example – Rear area, centre – Empty section 45

2.2 Fitting the PE/PEN busbar system 46

2.3 Fitting the N busbar system 52

2.4 Mounting the rear main busbar system 54

3. Connecting the riser section and the variant example for the rear area, centre 56

3.1 Connecting the riser section and the variant example for the rear area, centre 56

3.2 Joining the switchgear sections together – Fitting the baying connectors 57

3.3 Screw-fastening the longitudinal connectors 60

3.4 Fitting the N connection brackets 62

4. Modular front design 65

4.1 Fitting the panels and roof plate 65

5. Particular feature – busbar system 2 x 50 x 10 66

5.1 Fitting the N busbar system 66

5.2 Fitting the vertical main busbar system and the baying connectors 67

5.3 Connecting the riser section and the rear area section 69

6. Particular feature – Main busbar system as a 4-pole system 70

6.1 Fitting the stabiliser 70

6.2 Fitting the N busbar system 71

7. Particular feature – 800 mm enclosure depth (overview) 72

8. Particular feature – Cut-out for Form 2b 73

List of model numbers 74

FR

1. Montage de la zone d'installation verticale – jeux de barres dans la base à l'arrière au centre 6

1.1 Zone d'installation verticale de profondeur 600 mm ou 800 mm (4 x 50 x 10 mm) – jeu de barres principal tripolaire 6

1.2 Préparation de l'armoire modulaire 7

1.3 Montage sous rails de montage 8

1.4 Montage des supports de jeux de barres verticaux inférieurs 11

1.5 Montage des jeux de barres principaux inférieurs 14

1.6 Insertion des jeux de barres de distribution verticaux 18

1.7 Connexion aux jeux de barres de distribution verticaux 20

1.8 Montage des rails de montage supérieurs et des supports de jeux de barres 23

1.9 Montage des jeux de barres Terre / Terre-Neutre 30

1.10 Montage des jeux de barres Neutre 31

1.11 Montage des jeux de barres principaux verticalement 36

1.12 Montage des attaches de juxtaposition pour les jeux de barres principaux 38

1.13 Montage du stabilisateur 39

1.14 Serrage des vis 43

2. Exemple du montage au milieu à l'arrière – jeux de barres Neutre et Terre 45

2.1 Exemple du montage au milieu à l'arrière – zone vide 45

2.2 Montage des jeux de barres Terre / Terre-Neutre 46

2.3 Montage des jeux de barres Neutre 52

2.4 Montage des jeux de barres principaux à l'arrière 54

3. Raccordement zone de cheminement vertical et exemple de variante au milieu à l'arrière 56

3.1 Raccordement de la zone de cheminement vertical et de l'exemple de variante au milieu à l'arrière 56

3.2 Assemblage des différentes cellules de distribution électrique – montage des attaches de juxtaposition 57

3.3 Vissage des éléments de jonction longitudinaux 60

3.4 Montage des équerres de raccordement Neutre 62

4. Aménagement modulaire de la face avant 65

4.1 Montage des pièces plates et du toit 65

5. Caractéristiques particulières – jeu de barres avec 2 barres de courant 50 x 10 66

5.1 Montage des jeux de barres Neutre 66

5.2 Montage des jeux de barres principaux verticalement et des attaches de juxtaposition 67

5.3 Raccordement zone de cheminement vertical et zone à l'arrière 69

6. Caractéristique particulière – jeu de barres principal tétrapolaire 70

6.1 Montage du stabilisateur 70

6.2 Montage des jeux de barres Neutre 71

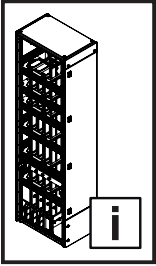

Inhaltsverzeichnis
Contents
Sommaire

FR

7.	Caractéristique particulière – profondeur d'armoire de 800 mm (vue d'ensemble)	72
8.	Caractéristique particulière – découpe forme 2b	73
	Liste des références	74

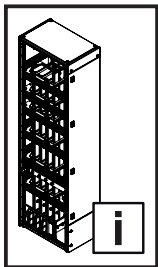

Inhaltsverzeichnis
Contents
Sommaire

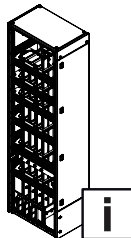

2-6,
74

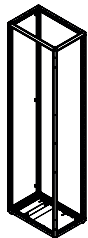

7

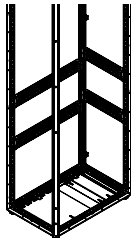

8-10

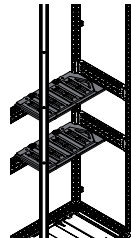

11-13

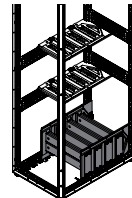

14-17



18-19

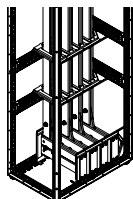

20-22

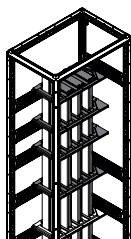

23-29

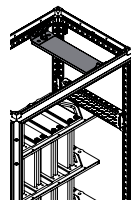

30

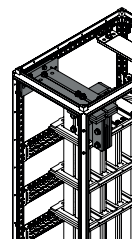

31-35

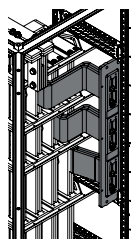

36-37

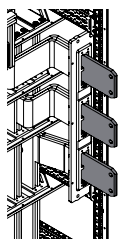

38

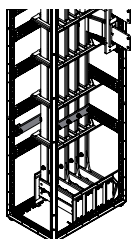

39-42

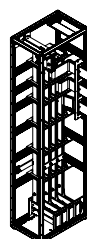

43-44

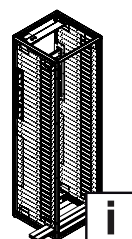

45

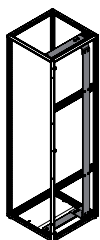

46-51

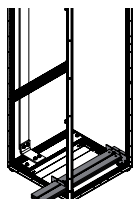

52-53

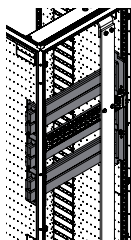

54-55

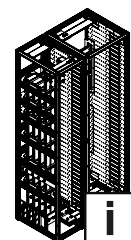

56

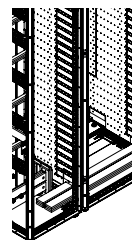

57-59

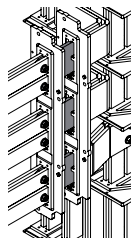

60-61

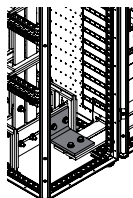

62-64

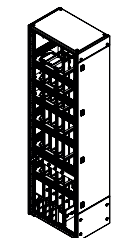

65

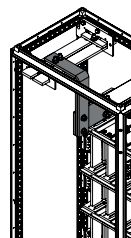

66

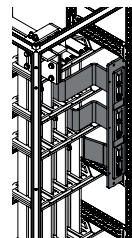

67-68

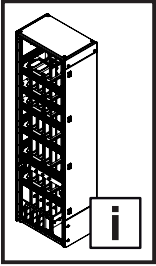

Inhaltsverzeichnis
Contents
Sommaire

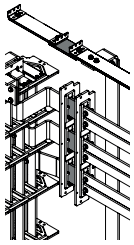

69

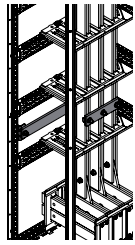

70

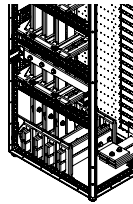

71

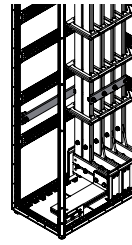

72

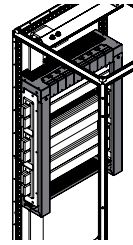

73

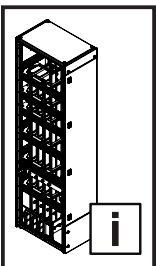

Mitgeltende Unterlagen
Other applicable documents
Autres documents applicables



DE

Für die hier beschriebenen Sammelschiene-
 komponenten steht diese Montageanleitung
 als Download unter www.rittal.de zur Verfü-
 gung. Für Schäden, die durch Nichtbeachtung
 dieser Anleitung entstehen, übernehmen wir
 keine Haftung. Zusätzlich gelten auch die
 Anleitungen des verwendeten Zubehörs sowie
 die VX25 Ri4Power Montageanleitung.

Bitte beachten Sie die Sicherheits- und
 Warnhinweise in der Montageanleitung „VX25
 Ri4Power – Schalt- und Energieverteilanlagen-
 System“.

**Montageanleitung VX25 Ri4Power – Schalt- und Energie-
 verteilanlagen-System**

**Assembly instructions VX25 Ri4Power – Switchgear and power
 distribution system**

Notice de montage VX25 Ri4Power – Distribution de courant

DE/EN/FR

EN

These assembly instructions for the described
 busbar components can be downloaded from
www.rittal.com. We cannot accept any liability
 for damage associated with failure to observe
 these instructions. The instructions for any
 accessories used, together with the VX25
 Ri4Power assembly instructions, also apply.

Please observe the safety and warning notes
 in the "VX25 Ri4Power – Switchgear and
 power distribution system" assembly instruc-
 tions.

FR

La présente notice de montage pour les com-
 posants du jeu de barres mentionnés ici peut
 être téléchargée sur le site internet
www.rittal.fr. Nous déclinons toute respon-
 sabilité en cas de dommages imputables à la
 non-observation des instructions contenues
 dans ce document. Veuillez également respec-
 ter les instructions relatives aux accessoires
 utilisés ainsi que la notice de montage VX25
 Ri4Power.

Veuillez respecter les consignes de sécurité et
 les avertissements figurant dans les instruc-
 tions de montage « VX25 Ri4Power – Distribu-
 tion de courant ».

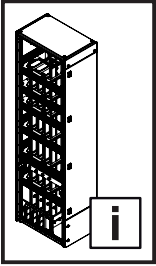

- 1. Montage Hochführungsfeld – Einbaulage Boden auf Rücken Mitte
- 1. Fitting the riser section – Mounting position: Base section via rear section in the centre
- 1. Montage de la zone d'installation verticale – jeux de barres dans la base à l'arrière au centre

- 1.1 Hochführungsfeld 600 mm oder 800 mm tief (4 x 50 x 10) – Hauptsammelschienensystem als 3-poliges System
- 1.1 Riser section 600 mm or 800 mm deep (4 x 50 x 10) – Main busbar system as a 3-pole system
- 1.1 Zone d'installation verticale de profondeur 600 mm ou 800 mm (4 x 50 x 10 mm) – jeu de barres principal tripolaire

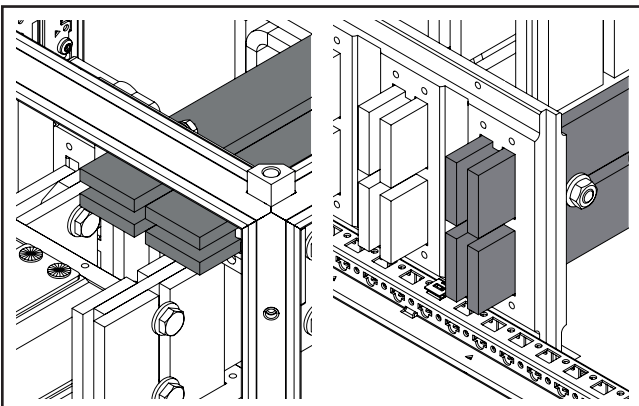
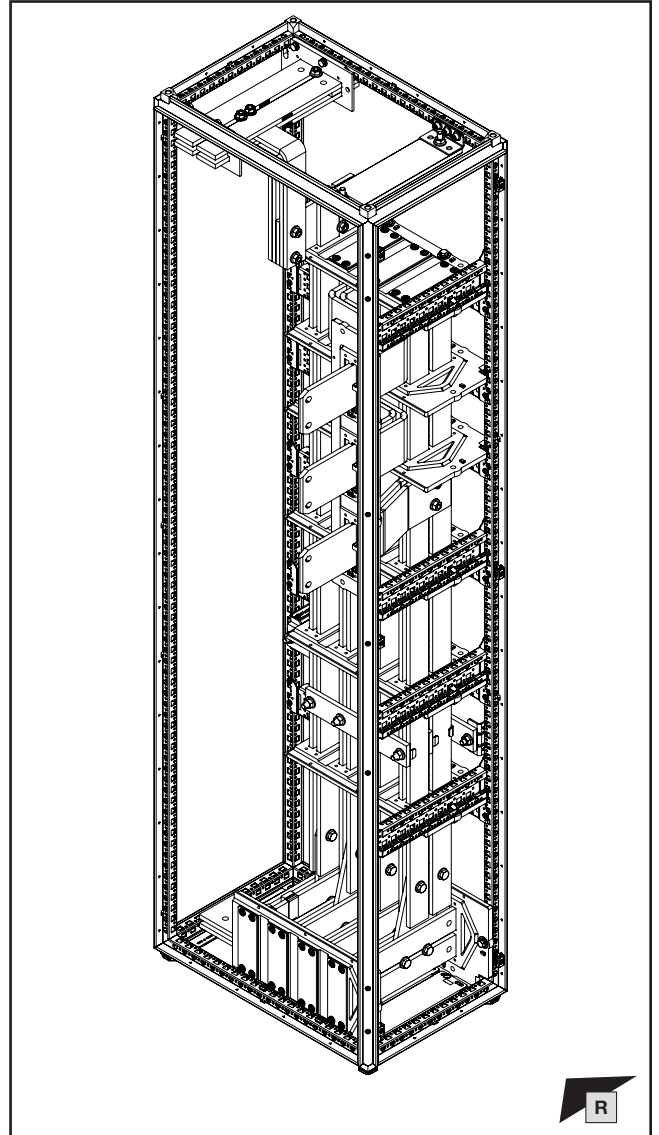
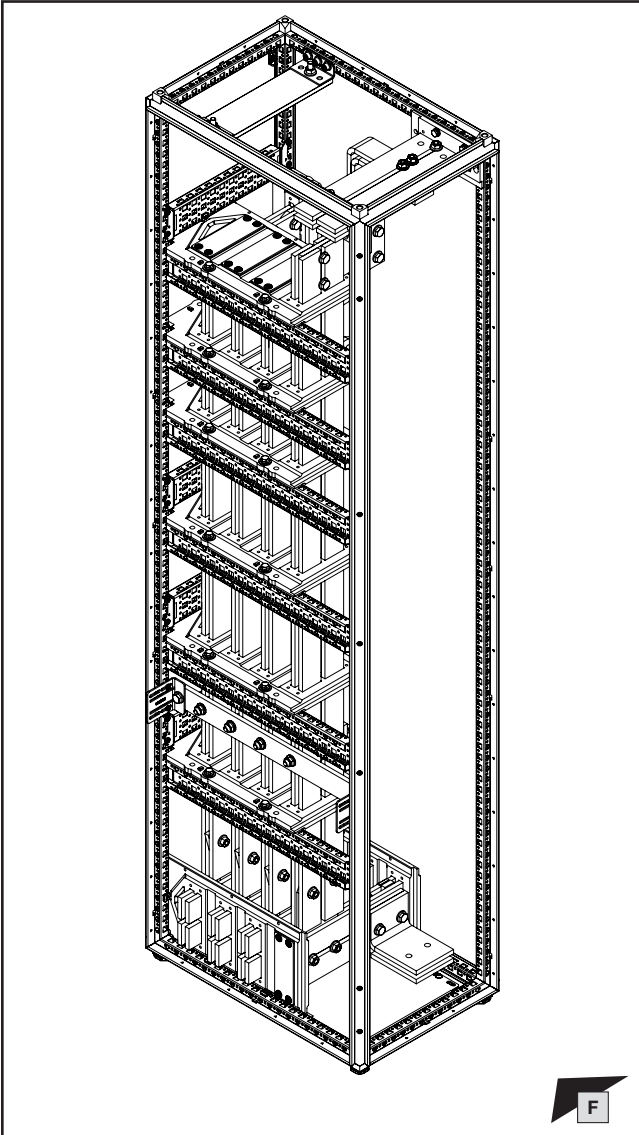

Hinweis / Note / Remarque

Neutralleiter N nach Wahl des Anlagenbetreibers im Bodenbereich oder im Dachbereich. Im Kapitel 1 wird die Montage im Dachbereich gezeigt, im Kapitel 6 die Montage im Bodenbereich.

Neutral conductor N in the base or roof area as selected by the system operator. Chapter 1 shows fitting in the roof area, chapter 6 fitting in the base area.

Neutre N dans la base ou sous le toit, selon le choix de l'exploitant de l'installation. Le montage sous le toit est montré dans le chapitre 1, le montage dans la base dans le chapitre 6.

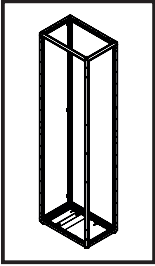

1. Montage Hochführungsfeld – Einbaulage Boden auf Rücken Mitte
1. Fitting the riser section – Mounting position: Base section via rear section in the centre
1. Montage de la zone d'installation verticale – jeux de barres dans la base à l'arrière au centre

- 1.2 Vorbereitung Modulschrank
- 1.2 Preparing the modular enclosure
- 1.2 Préparation de l'armoire modulaire

Montageanleitung VX25 Ri4Power – Schalt- und Energieverteilanlagen-System

Assembly instructions VX25 Ri4Power – Switchgear and power distribution system

Notice de montage VX25 Ri4Power – Distribution de courant

DE/EN/FR



Hinweis / Note / Remarque

Vorbereitende Arbeiten: siehe o. g. Anleitung, Kapitel „Demontage Flachteile“ und „Vorbereitung Montage Frontblenden“.

Preparatory work: see above mentioned assembly instructions, chapter "Dismantling panels" and "Preparation of mounting front panels".

Pour les travaux préliminaires, voir les chapitres « Démontage des pièces plates » et « Préparation du montage des faces avant » de la notice de montage ci-dessus.



Hinweis / Note / Remarque

Für Schutzzeitigkeit Störlichtbogenklasse A/B Montagereihenfolge in den entsprechenden Kapiteln der o. g. Anleitung beachten.

For arcing class A/B protection, please follow the assembly sequence as set out in the relevant chapters of the aforementioned assembly instructions.

Pour la protection contre les arcs électriques de catégorie A/B, suivez la séquence de montage indiquée dans les chapitres correspondantes des instructions ci-dessus.

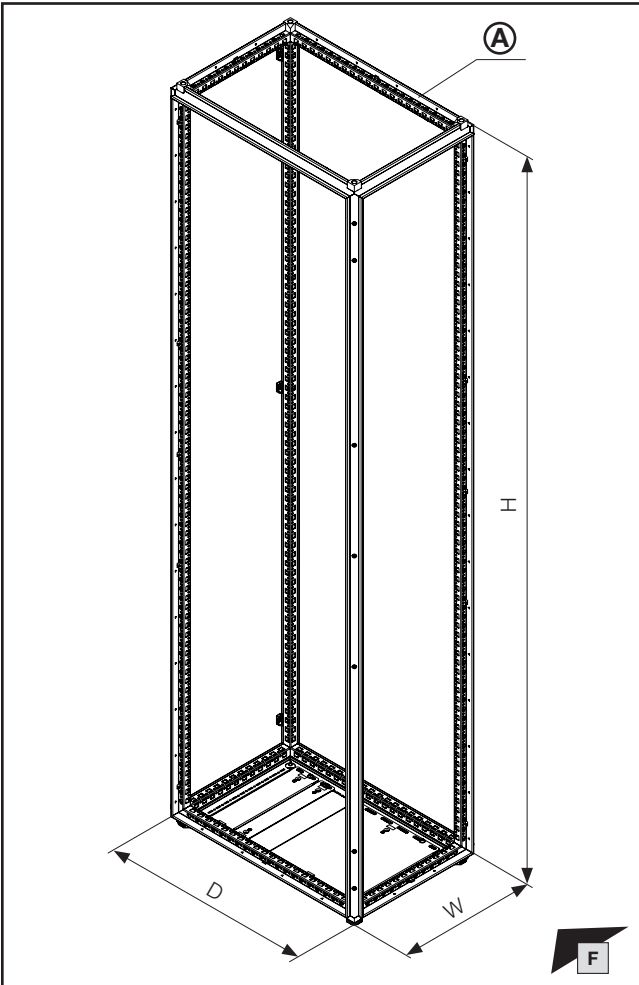

Hinweis / Note / Remarque

Die Angaben „W“ (Breite), „H“ (Höhe) und „D“ (Tiefe) der Schränke beziehen sich jeweils auf die nominalen Abmessungen der Schränke.

The information "W" (width), "H" (height) and "D" (depth) each refer to the nominal dimensions of the enclosures.

Les informations « W » (largeur), « H » (hauteur) et « D » (profondeur) se réfèrent chacune aux dimensions nominales des armoires.



Hinweis / Note / Remarque

Alternativ: Basisschrank aus Produktauswahl „Anreih-Schranksystem VX25“.

Option: Basic enclosure from the "baying enclosure system VX25" product selection.

Option : armoire électrique juxtaposable VX25 classique.

W mm	H mm	D mm	Ⓐ Best.-Nr. Model No. Référence
400	2000	600	9680.406
400	2000	800	9680.408
400	2200	600	9680.426
400	2200	800	9680.428

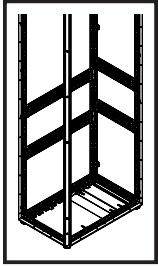

DE EN FR



1. Montage Hochführungsfeld – Einbaulage Boden auf Rücken Mitte
1. Fitting the riser section – Mounting position: Base section via rear section in the centre
1. Montage de la zone d'installation verticale – jeux de barres dans la base à l'arrière au centre

- 1.3 Montage untere System-Chassis
- 1.3 Fitting the lower punched sections with mounting flanges
- 1.3 Montage sous rails de montage

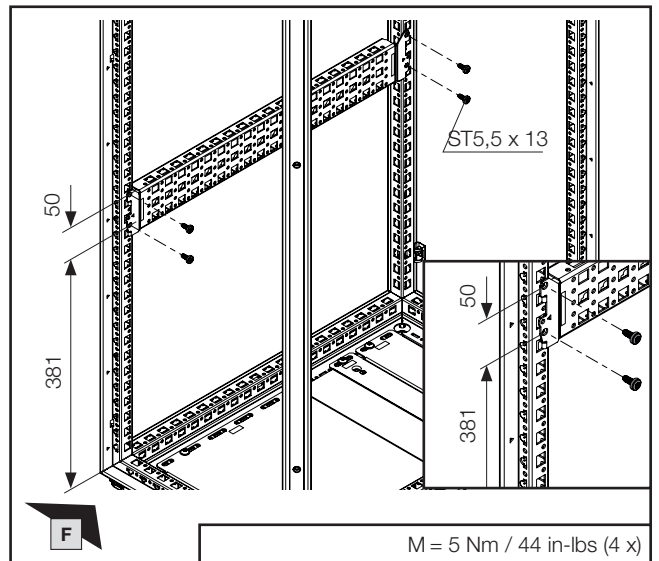
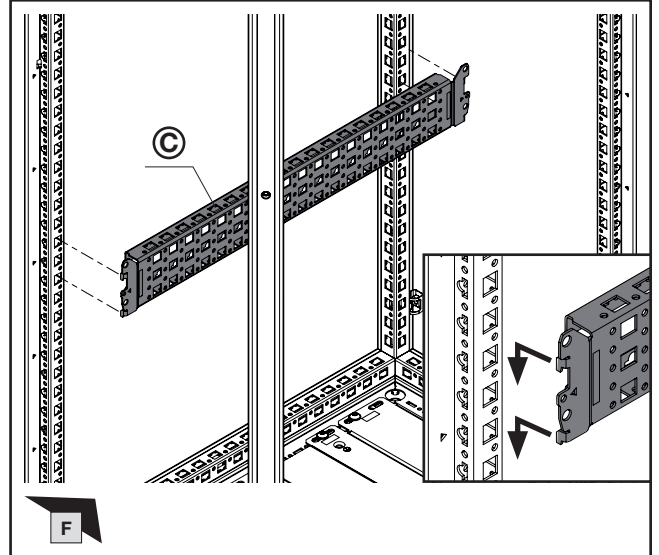
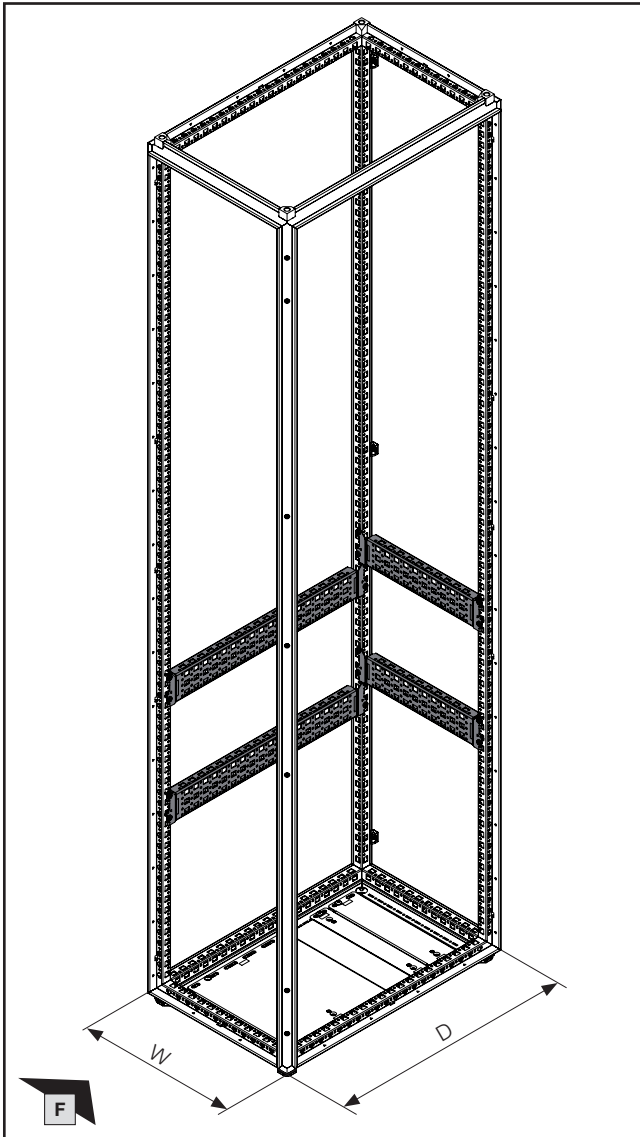

M = 5 Nm / 44 in-lbs (4 x)

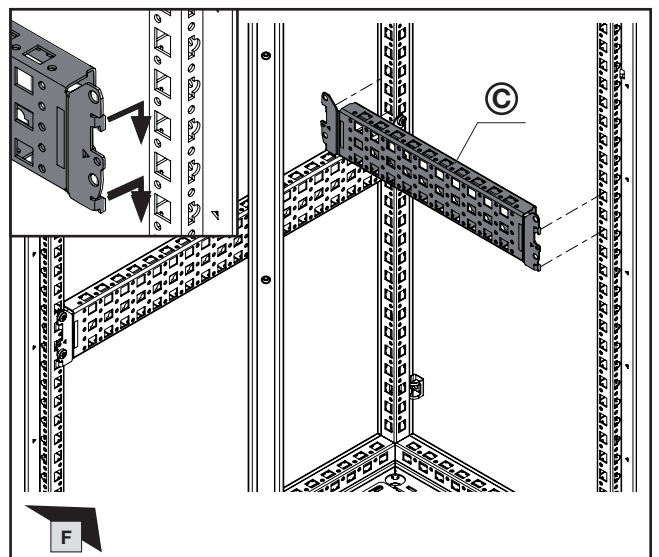

D mm	W mm	© Best.-Nr. Model No. Référence
x	400	8617.110
600	x	8617.130
800	x	8617.140

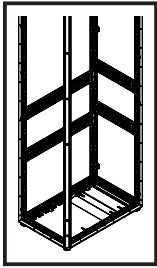

DE EN FR



1. Montage Hochführungsfeld – Einbaulage Boden auf Rücken Mitte
1. Fitting the riser section – Mounting position: Base section via rear section in the centre
1. Montage de la zone d'installation verticale – jeux de barres dans la base à l'arrière au centre

- 1.3 Montage untere System-Chassis
- 1.3 Fitting the lower punched sections with mounting flanges
- 1.3 Montage sous rails de montage

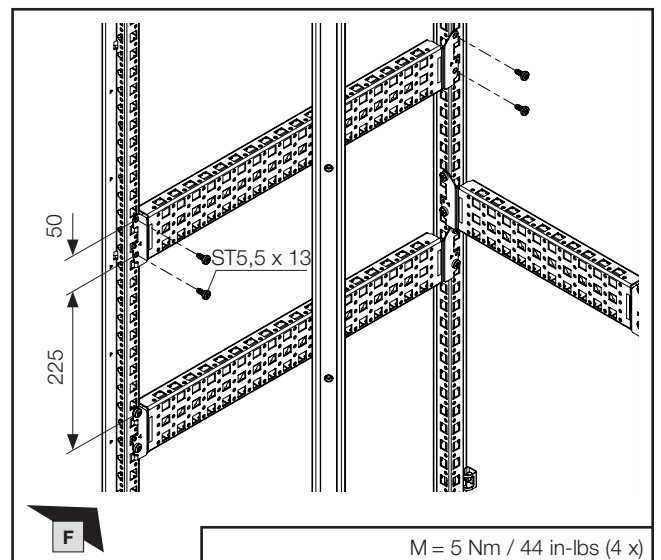
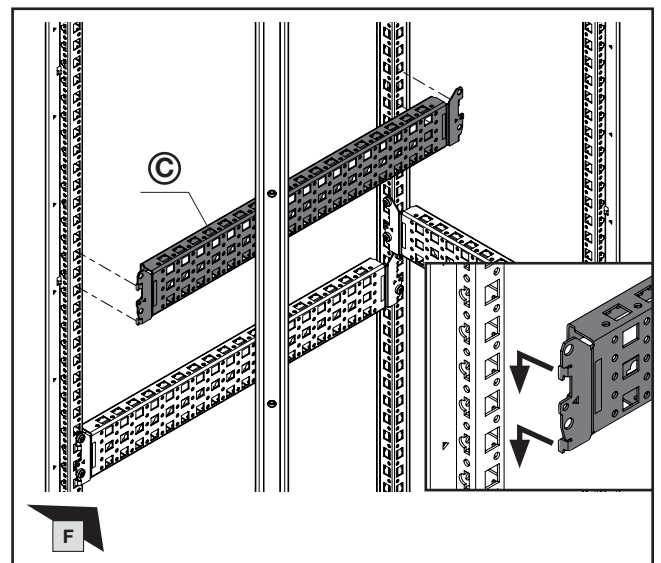
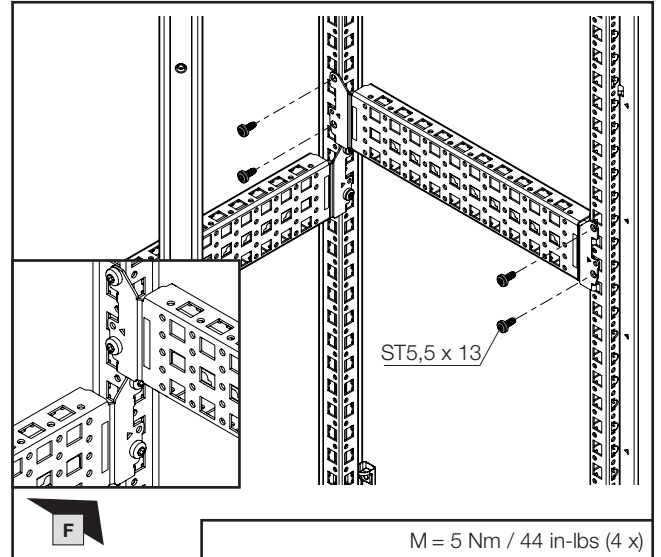
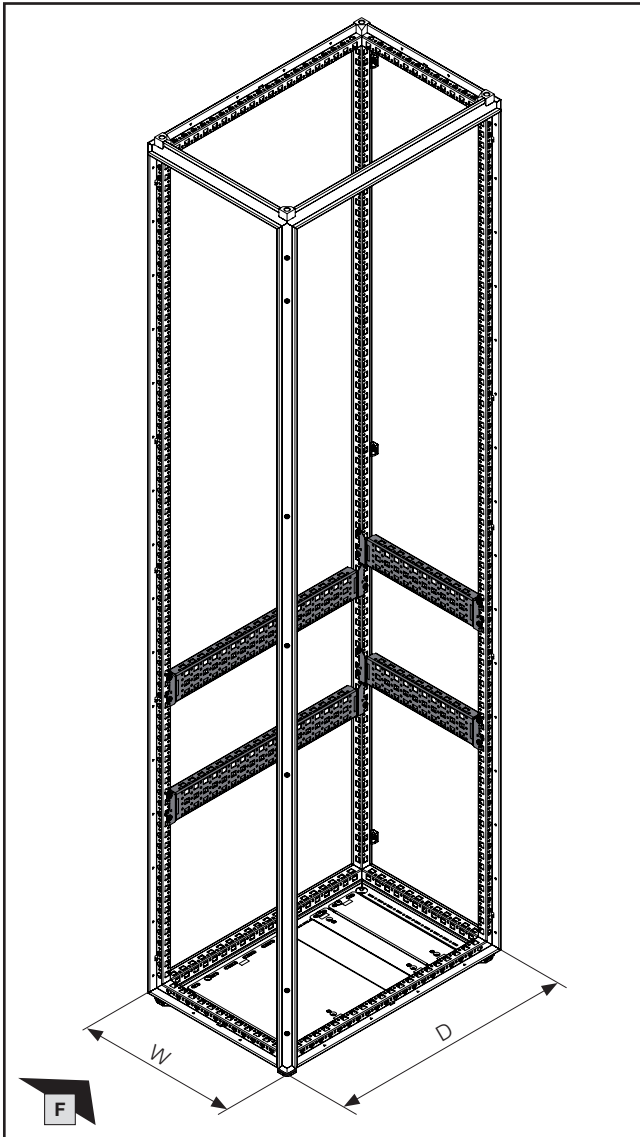

D mm	W mm	© Best.-Nr. Model No. Référence
x	400	8617.110
600	x	8617.130
800	x	8617.140

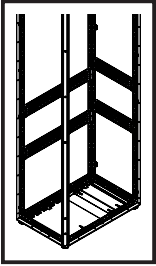

DE EN FR



1. Montage Hochführungsfeld – Einbaulage Boden auf Rücken Mitte
1. Fitting the riser section – Mounting position: Base section via rear section in the centre
1. Montage de la zone d'installation verticale – jeux de barres dans la base à l'arrière au centre

- 1.3 Montage untere System-Chassis
- 1.3 Fitting the lower punched sections with mounting flanges
- 1.3 Montage sous rails de montage

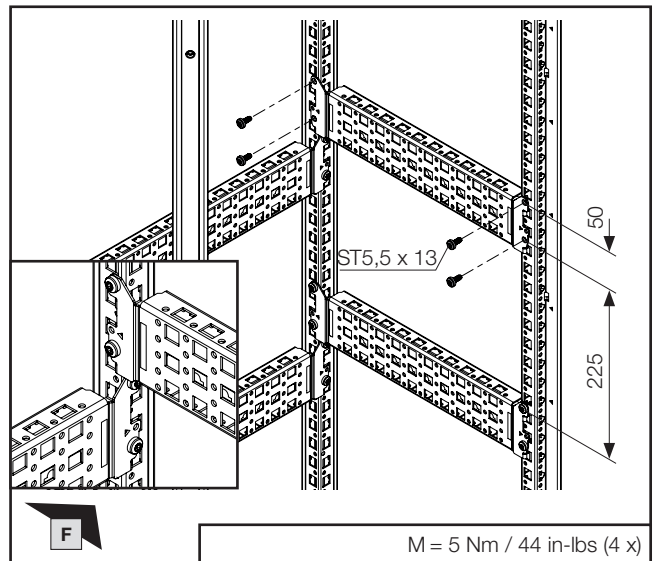
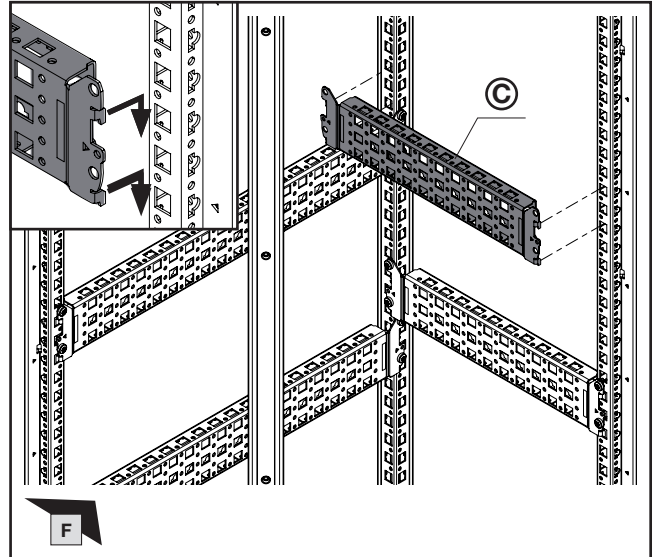
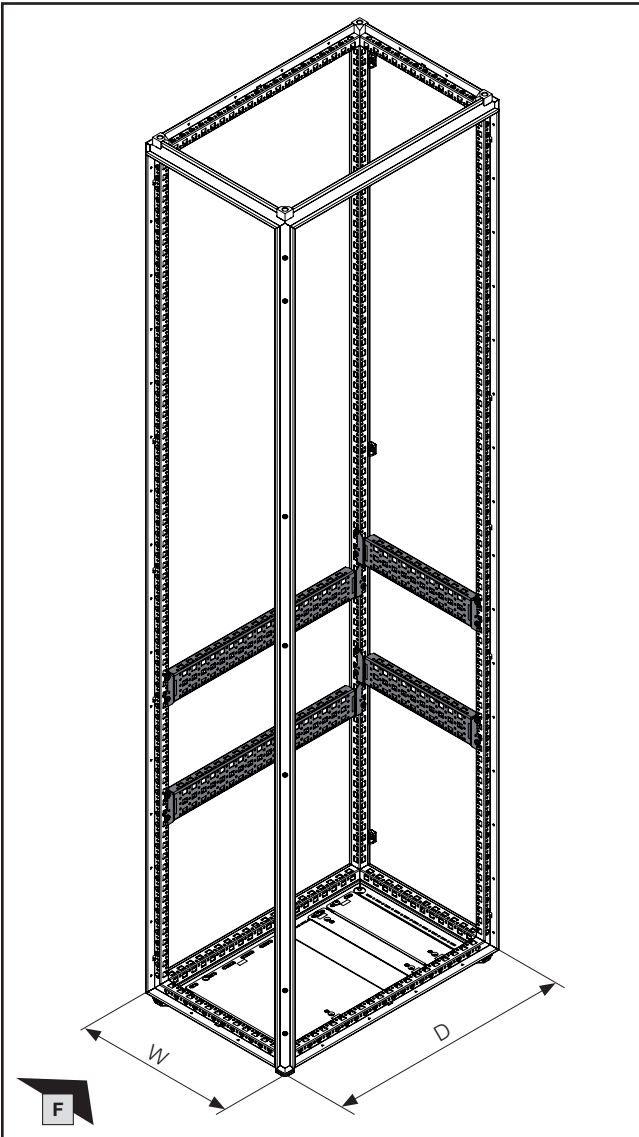

D mm	W mm	© Best.-Nr. Model No. Référence
x	400	8617.110
600	x	8617.130
800	x	8617.140

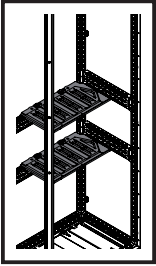

DE EN FR



- 1. Montage Hochführungsfeld – Einbaulage Boden auf Rücken Mitte
- 1. Fitting the riser section – Mounting position: Base section via rear section in the centre
- 1. Montage de la zone d'installation verticale – jeux de barres dans la base à l'arrière au centre

- 1.4 Montage untere Sammelschienenhalter vertikal
- 1.4 Fitting the lower busbar supports, vertical
- 1.4 Montage des supports de jeux de barres verticaux inférieurs

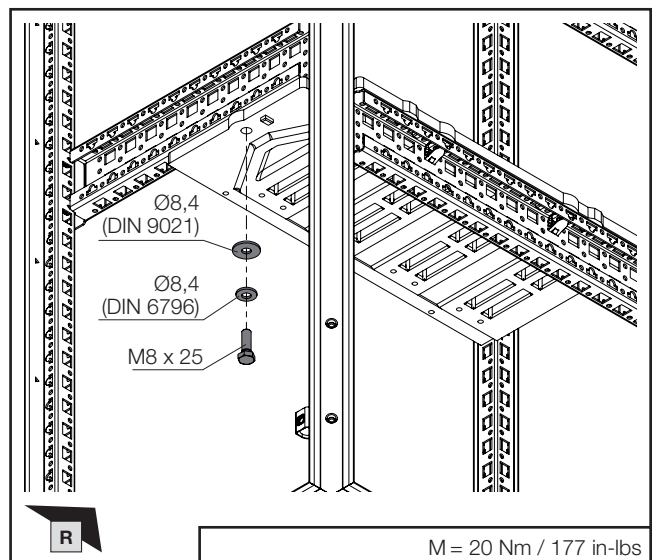
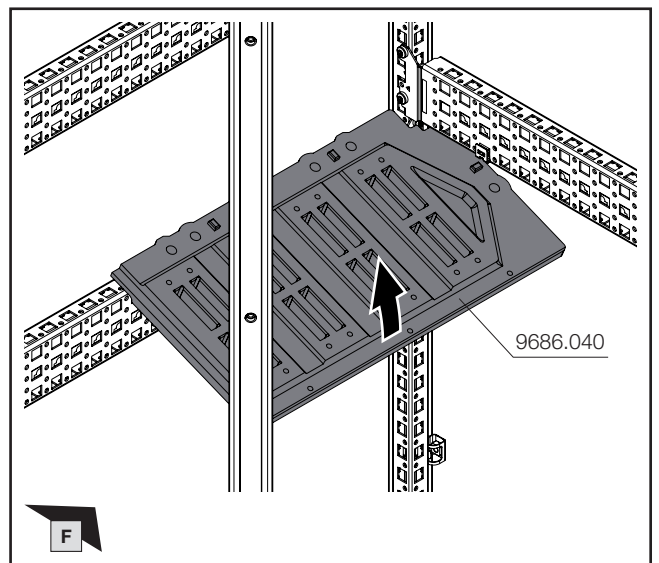
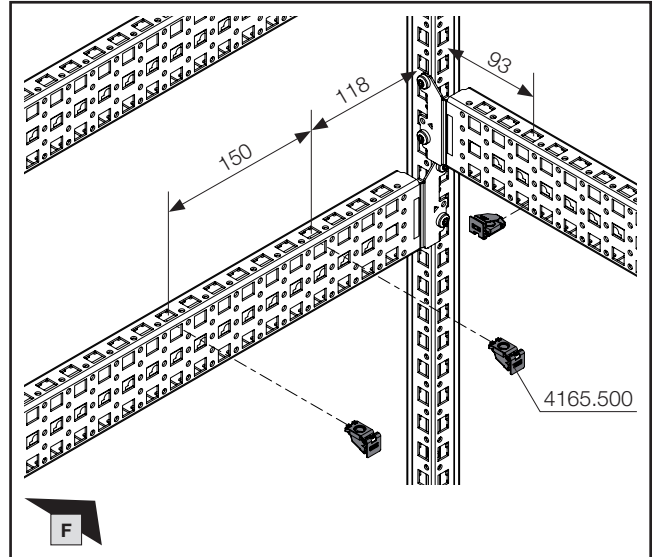
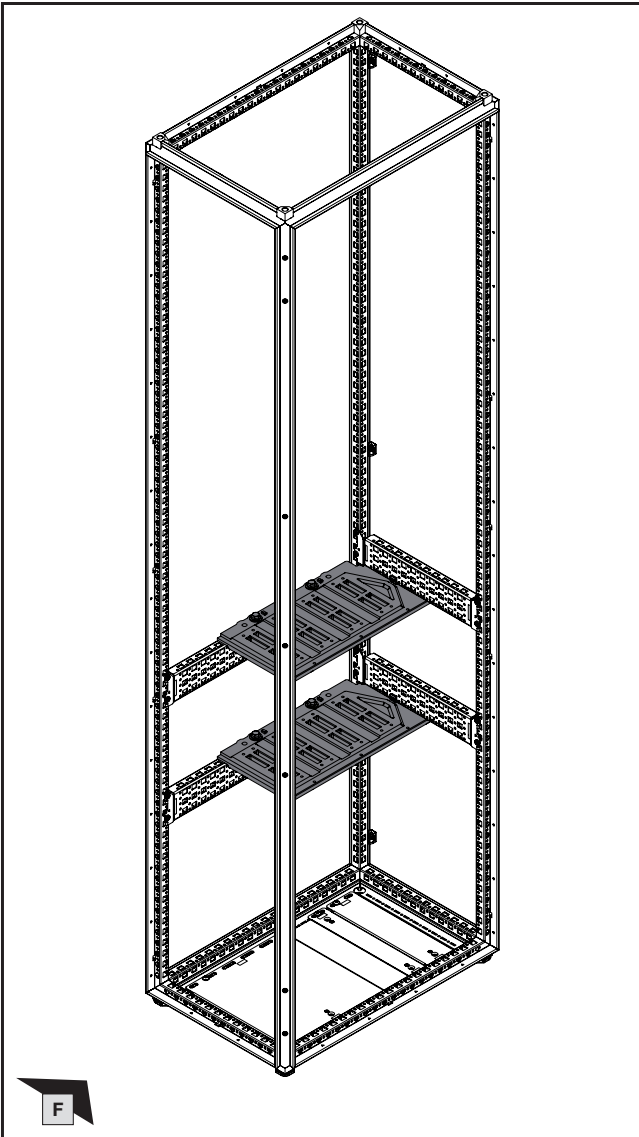

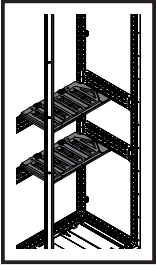

DE EN FR



1. Montage Hochführungsfeld – Einbaulage Boden auf Rücken Mitte
1. Fitting the riser section – Mounting position: Base section via rear section in the centre
1. Montage de la zone d'installation verticale – jeux de barres dans la base à l'arrière au centre

- 1.4 Montage untere Sammelschienenhalter vertikal
- 1.4 Fitting the lower busbar supports, vertical
- 1.4 Montage des supports de jeux de barres verticaux inférieurs

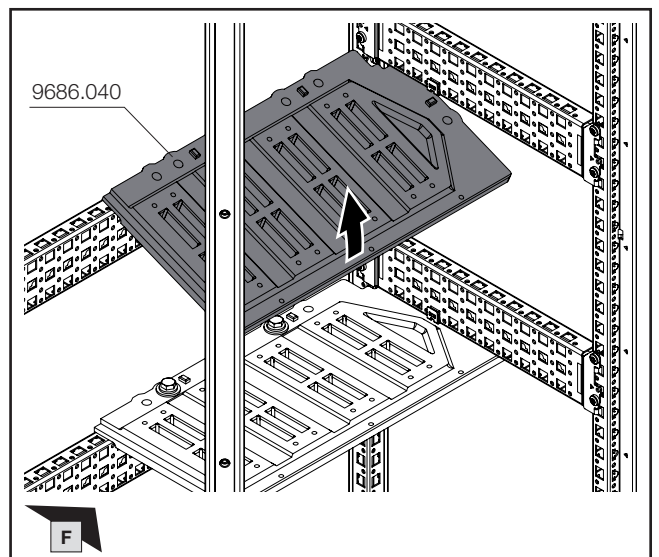
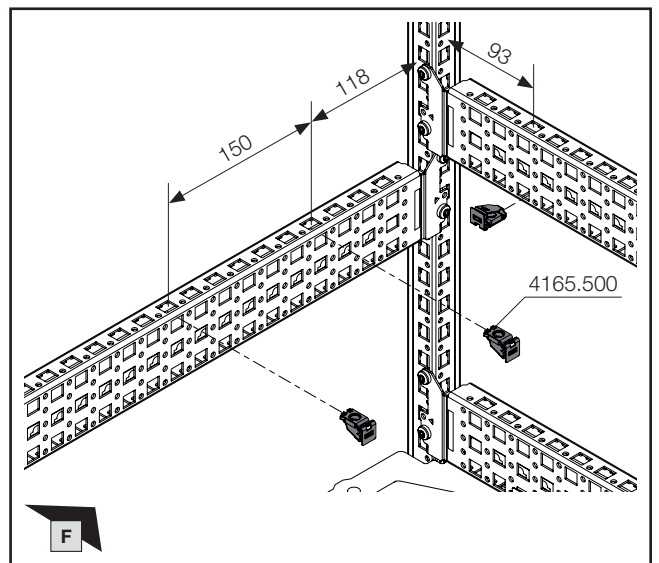
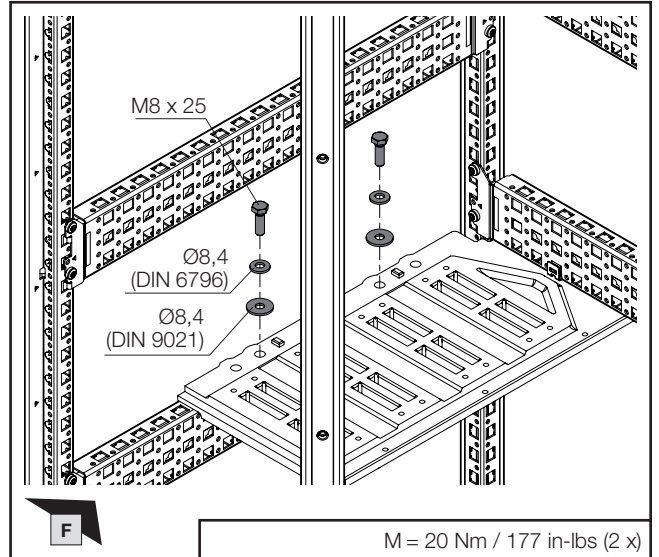
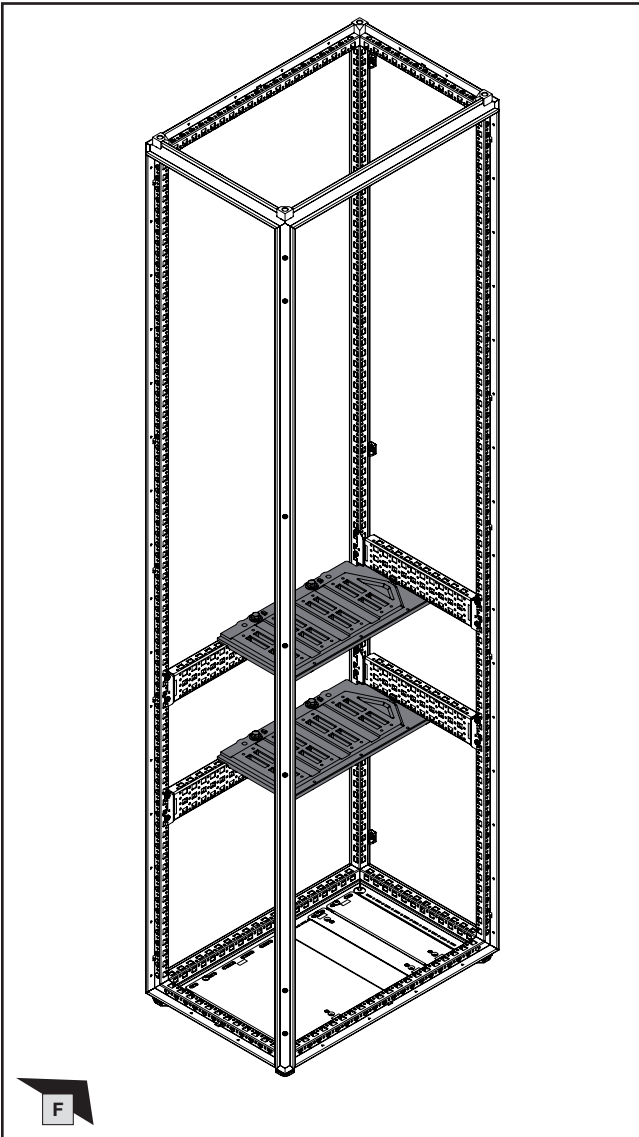

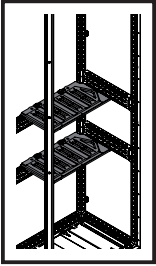

SW13



DE EN FR



1. Montage Hochführungsfeld – Einbaulage Boden auf Rücken Mitte
1. Fitting the riser section – Mounting position: Base section via rear section in the centre
1. Montage de la zone d'installation verticale – jeux de barres dans la base à l'arrière au centre

- 1.4 Montage untere Sammelschienenhalter vertikal
- 1.4 Fitting the lower busbar supports, vertical
- 1.4 Montage des supports de jeux de barres verticaux inférieurs

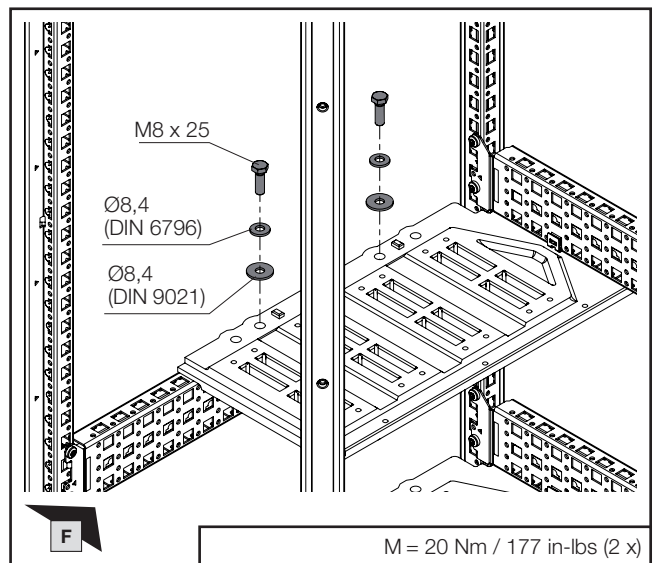
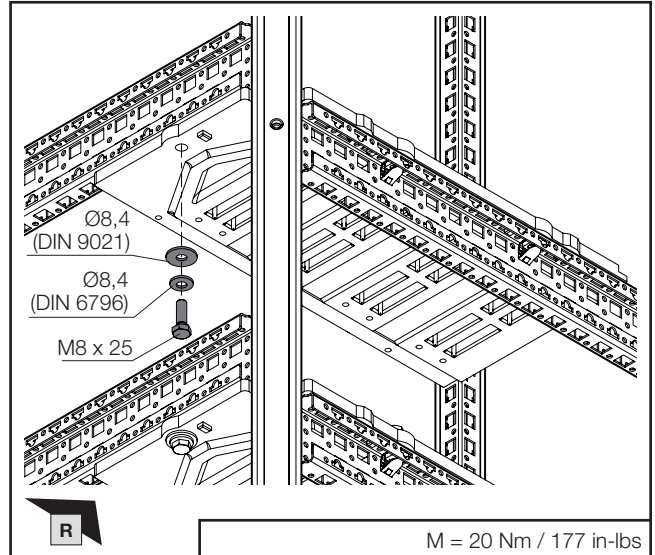
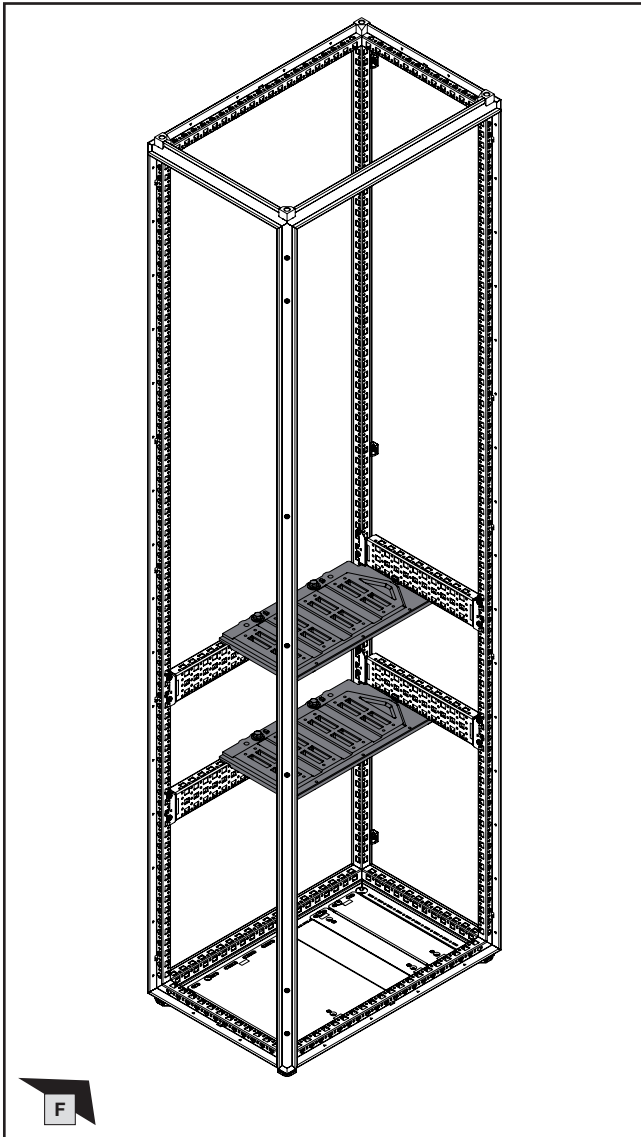

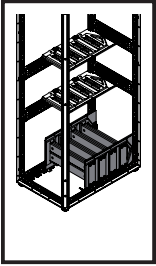

DE EN FR



1. Montage Hochführungsfeld – Einbaulage Boden auf Rücken Mitte
1. Fitting the riser section – Mounting position: Base section via rear section in the centre
1. Montage de la zone d'installation verticale – jeux de barres dans la base à l'arrière au centre

- 1.5 Montage des unteren Hauptschienensystems
- 1.5 Fitting the lower main busbar system
- 1.5 Montage des jeux de barres principaux inférieurs

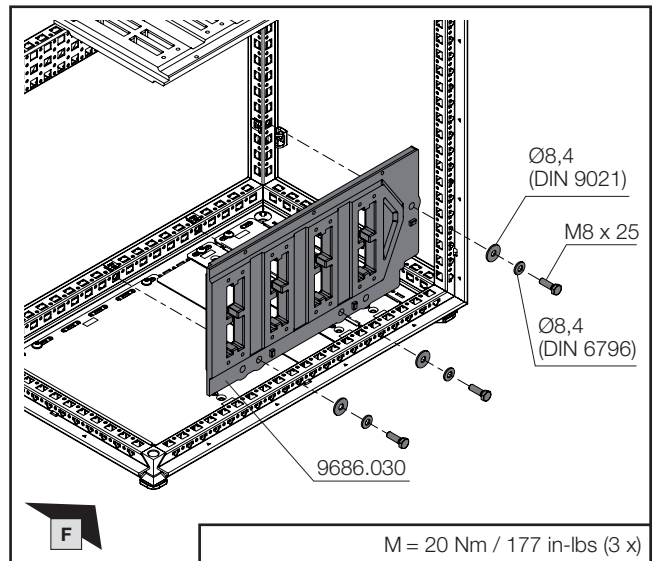
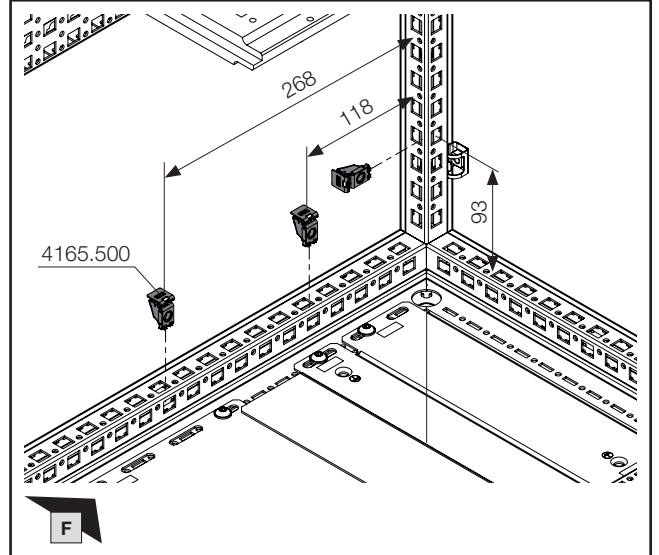
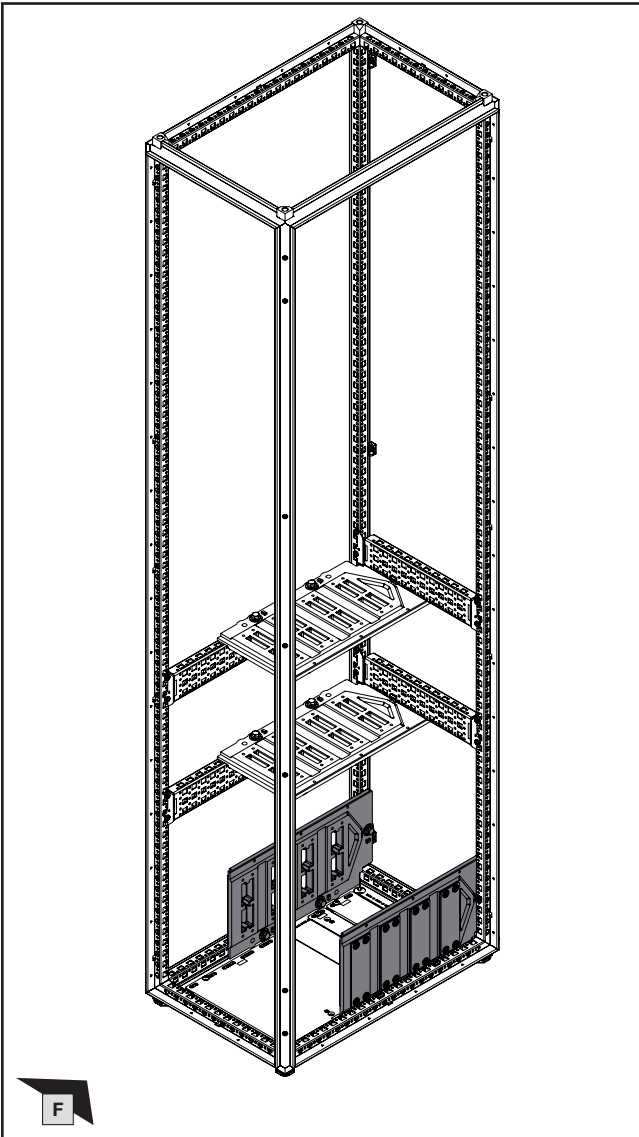

M = 20 Nm / 177 in-lbs (3 x)

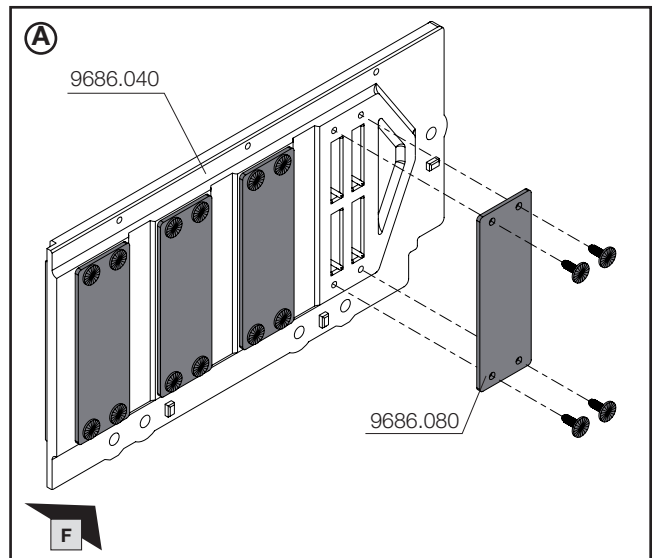

Montageanleitung VX25 Ri4Power – Schalt- und Energieverteilanlagen-System

Assembly instructions VX25 Ri4Power – Switchgear and power distribution system

Notice de montage VX25 Ri4Power – Distribution de courant

DE/EN/FR



Hinweis / Note / Remarque

Für Schutzeigenschaft Störlichtbogenklasse B Montagerihenfolge in den entsprechenden Abschnitten der o. g. Anleitung beachten.

For arcing class B protection, please follow the assembly sequence as set out in the relevant chapters of the aforementioned assembly instructions.

Pour la protection contre les arcs électriques de catégorie B, suivez la séquence de montage indiquée dans les sections correspondantes des instructions ci-dessus.

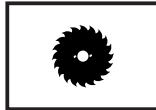
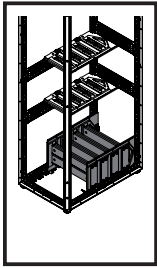

DE EN FR



1. Montage Hochführungsfeld – Einbaulage Boden auf Rücken Mitte
1. Fitting the riser section – Mounting position: Base section via rear section in the centre
1. Montage de la zone d'installation verticale – jeux de barres dans la base à l'arrière au centre

- 1.5 Montage des unteren Hauptschienensystems
- 1.5 Fitting the lower main busbar system
- 1.5 Montage des jeux de barres principaux inférieurs

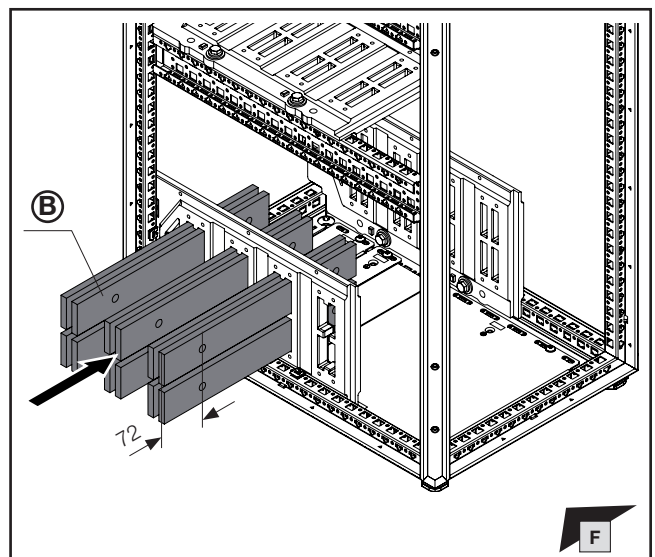
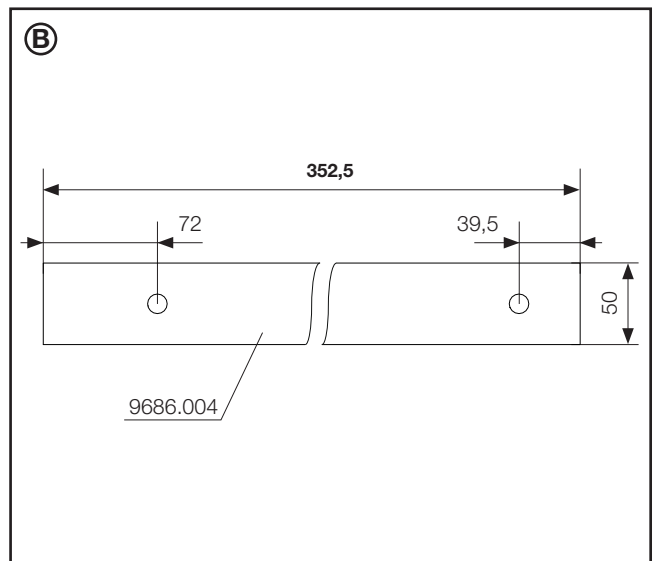
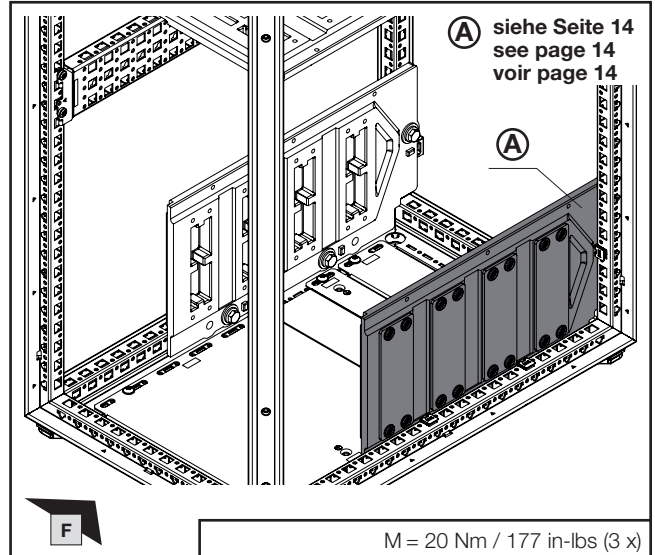
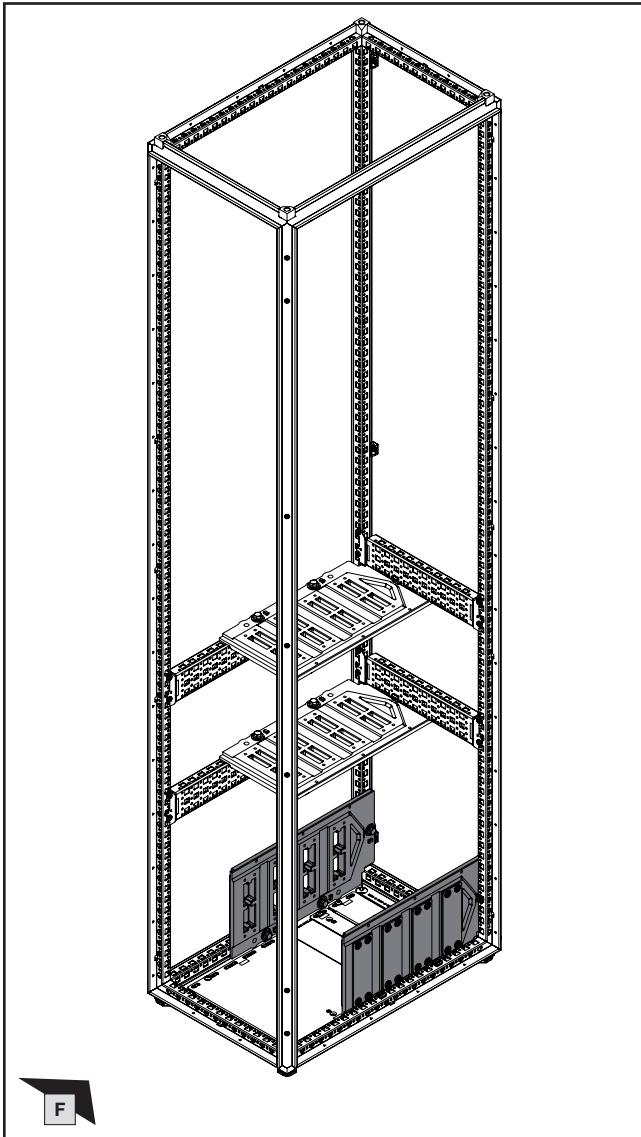

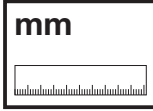
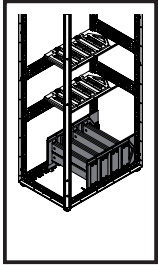

1. Montage Hochführungsfeld – Einbaulage Boden auf Rücken Mitte
 1. Fitting the riser section – Mounting position: Base section via rear section in the centre
 1. Montage de la zone d'installation verticale – jeux de barres dans la base à l'arrière au centre

- 1.5 Montage des unteren Hauptschienensystems
 1.5 Fitting the lower main busbar system
 1.5 Montage des jeux de barres principaux inférieurs

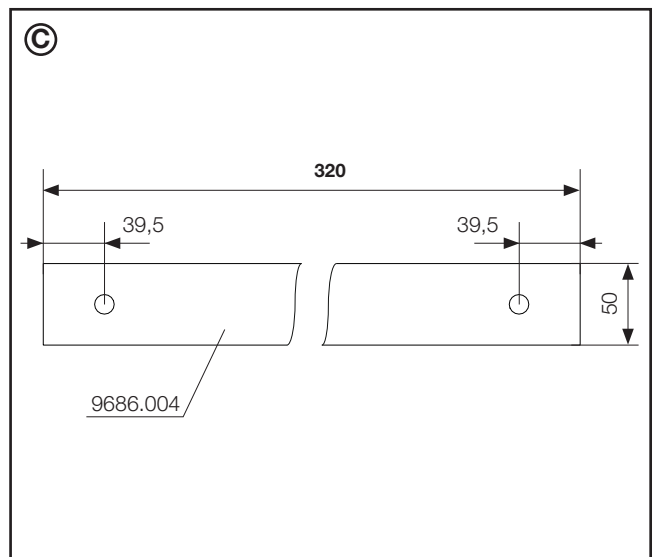
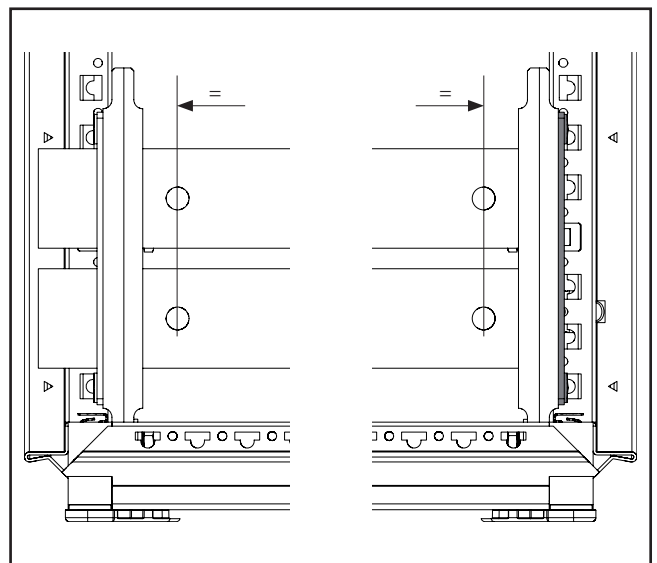
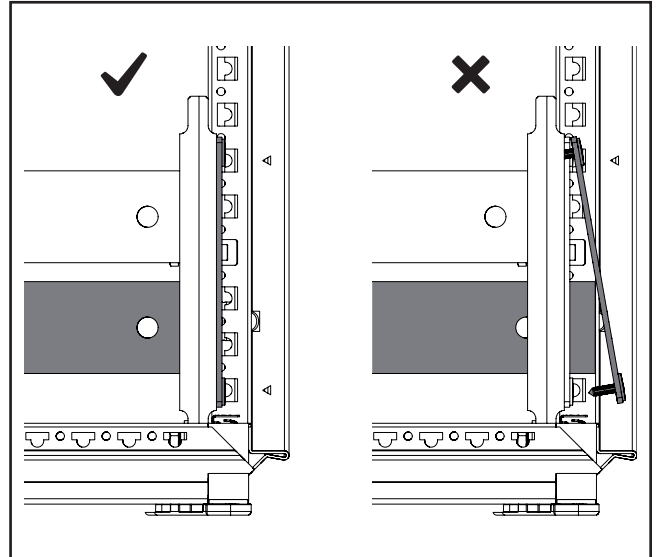
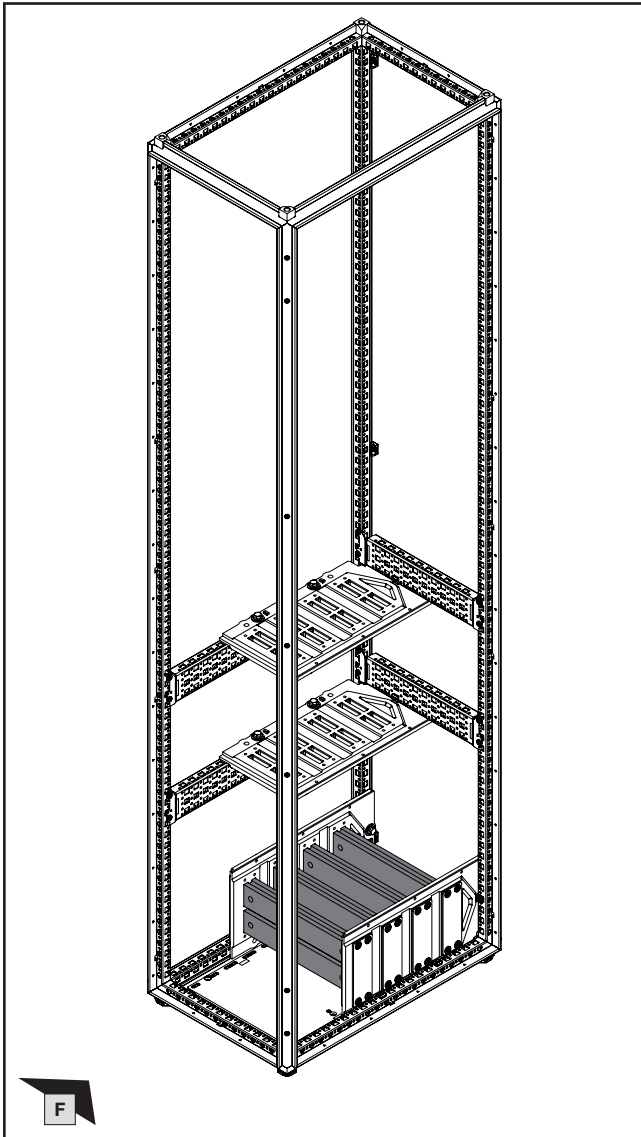

Hinweis / Note / Remarque ©
 Längsverbinder und vertikale Schienen nur bei separat im Dach geführtem N/PEN (siehe Kapitel 1.1).
 Longitudinal connectors and vertical rails only with N/PEN routed separately in the roof (see chapter 1.1).
 Éléments de jonction longitudinaux et barres verticales uniquement avec N/PEN qui chemine séparément sous le toit (voir chapitre 1.1).

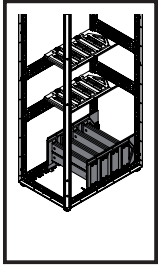

- 1. Montage Hochführungsfeld – Einbaulage Boden auf Rücken Mitte
- 1. Fitting the riser section – Mounting position: Base section via rear section in the centre
- 1. Montage de la zone d'installation verticale – jeux de barres dans la base à l'arrière au centre

- 1.5 Montage des unteren Hauptschienensystems
- 1.5 Fitting the lower main busbar system
- 1.5 Montage des jeux de barres principaux inférieurs

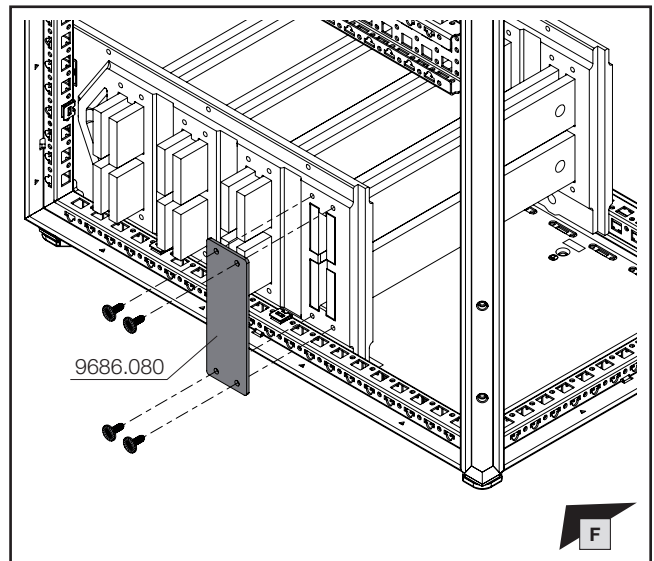
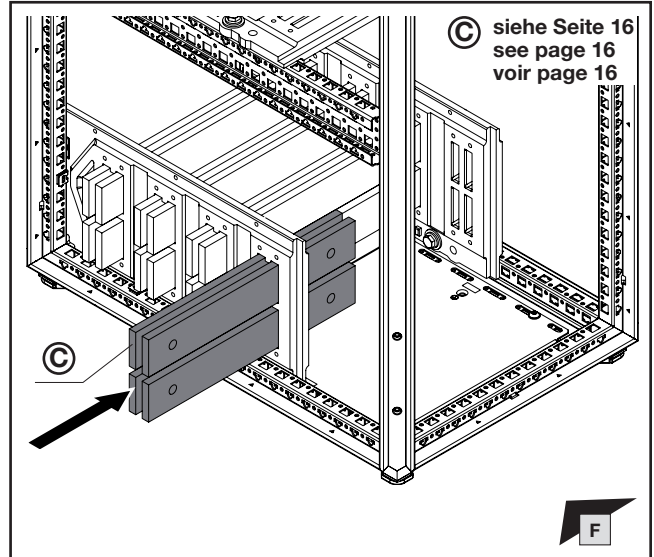
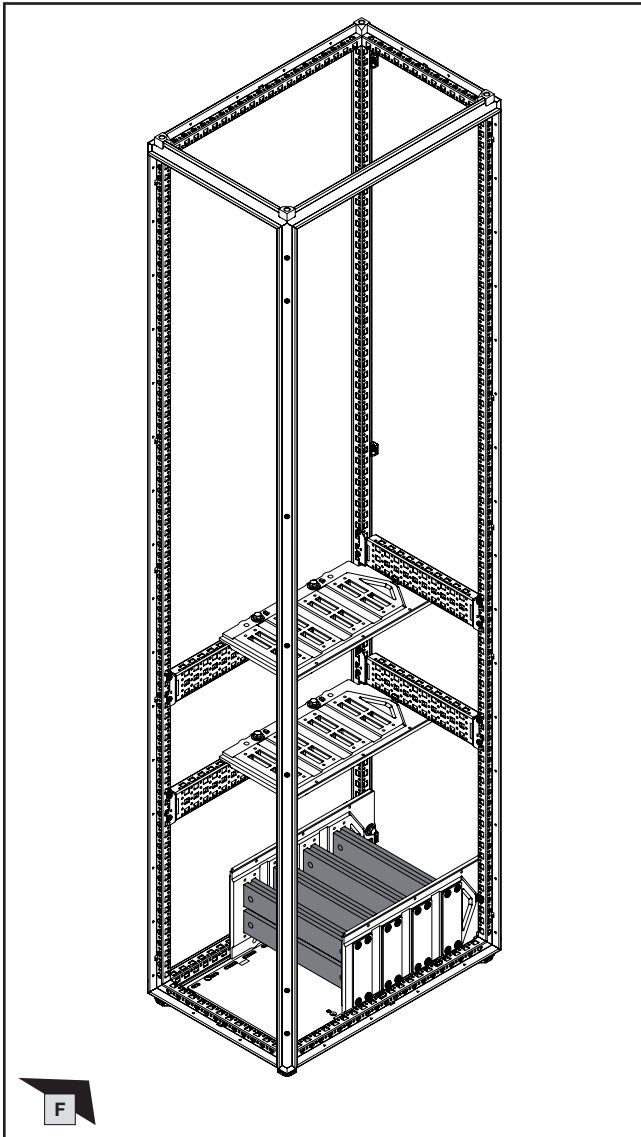

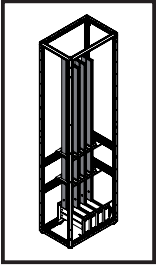

1. Montage Hochführungsfeld – Einbaulage Boden auf Rücken Mitte
1. Fitting the riser section – Mounting position: Base section via rear section in the centre
1. Montage de la zone d'installation verticale – jeux de barres dans la base à l'arrière au centre

- 1.6 Einbringung vertikale Verteilsammelschienen
- 1.6 Incorporating the vertical distribution busbars
- 1.6 Insertion des jeux de barres de distribution verticaux

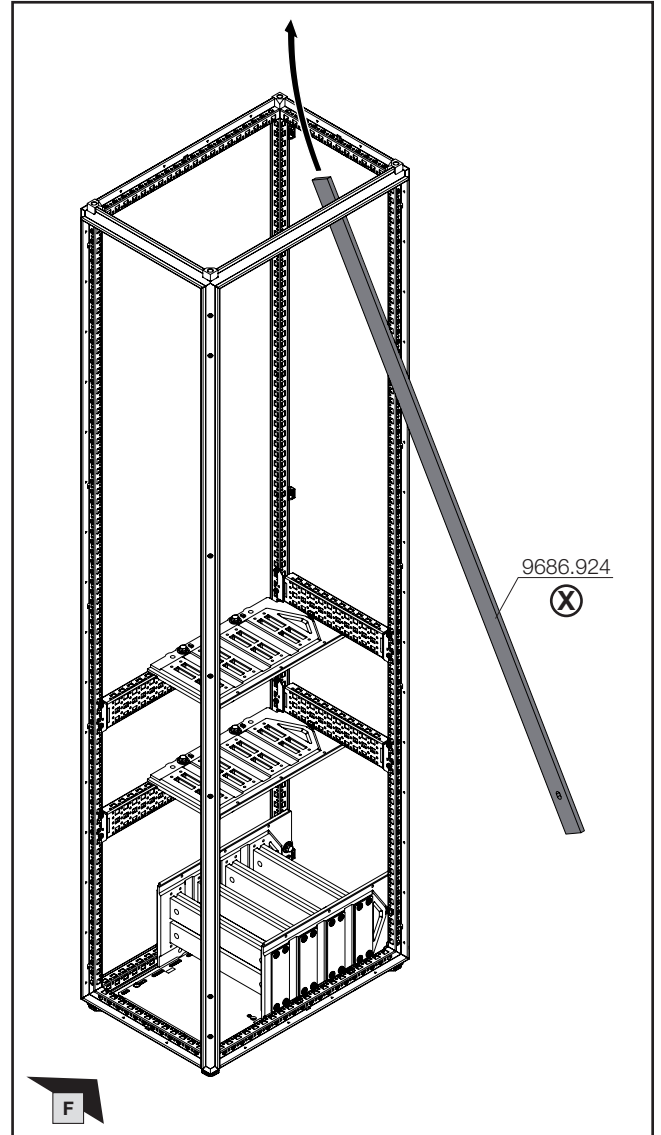
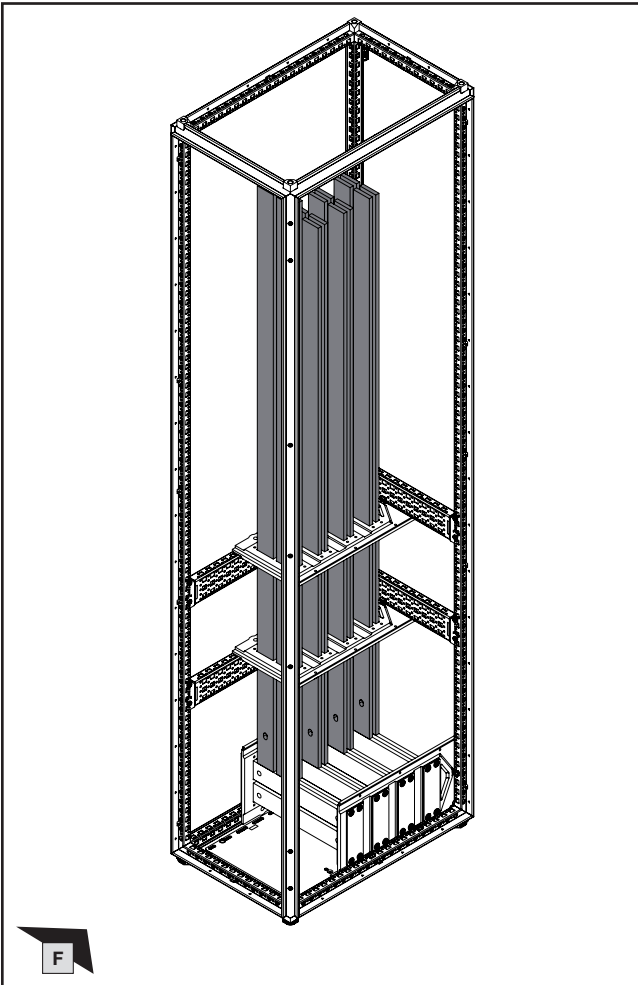

Hinweis / Note / Remarque (X)

Die Länge der Sammelschienen wird mit Hilfe der Online-Berechnungssoftware „RiPower“ im Niederspannungsschaltanlagen Konfigurator ermittelt.

The length of the busbars is determined using the online calculation software "RiPower" in the low-voltage switchgear configurator.

La longueur des jeux de barres est déterminée à l'aide du logiciel de calcul en ligne « RiPower » du configurateur de TGBT.



RiPower

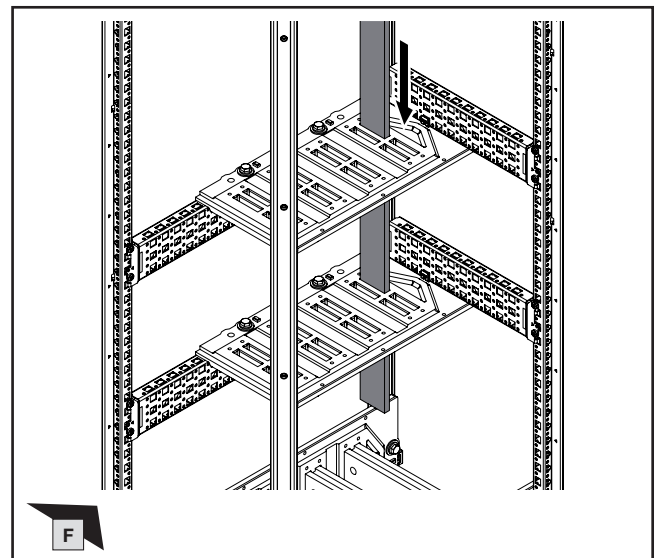

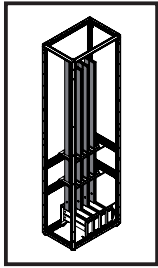

1. Montage Hochführungsfeld – Einbaulage Boden auf Rücken Mitte
1. Fitting the riser section – Mounting position: Base section via rear section in the centre
1. Montage de la zone d'installation verticale – jeux de barres dans la base à l'arrière au centre

- 1.6 Einbringung vertikale Verteilsammelschienen
- 1.6 Incorporating the vertical distribution busbars
- 1.6 Insertion des jeux de barres de distribution verticaux

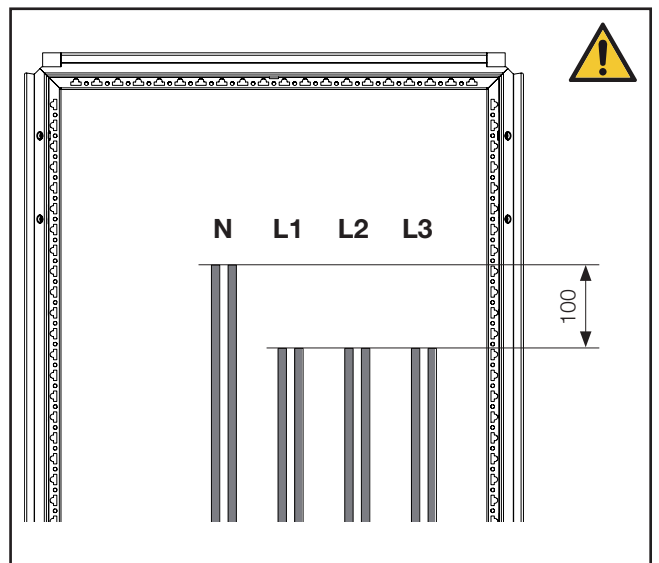
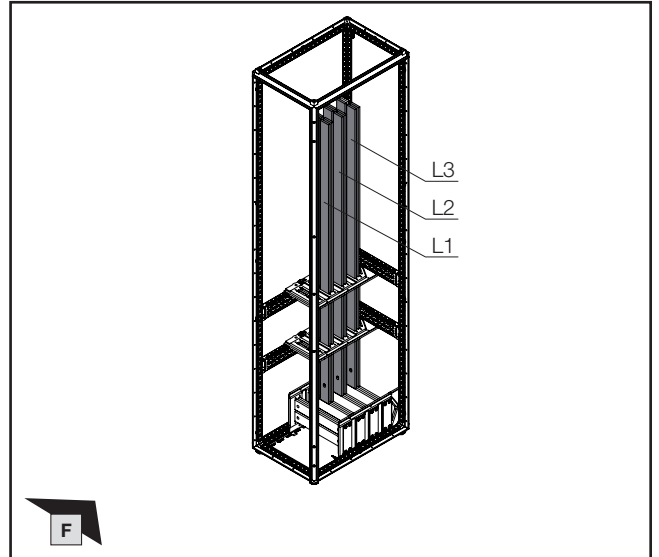
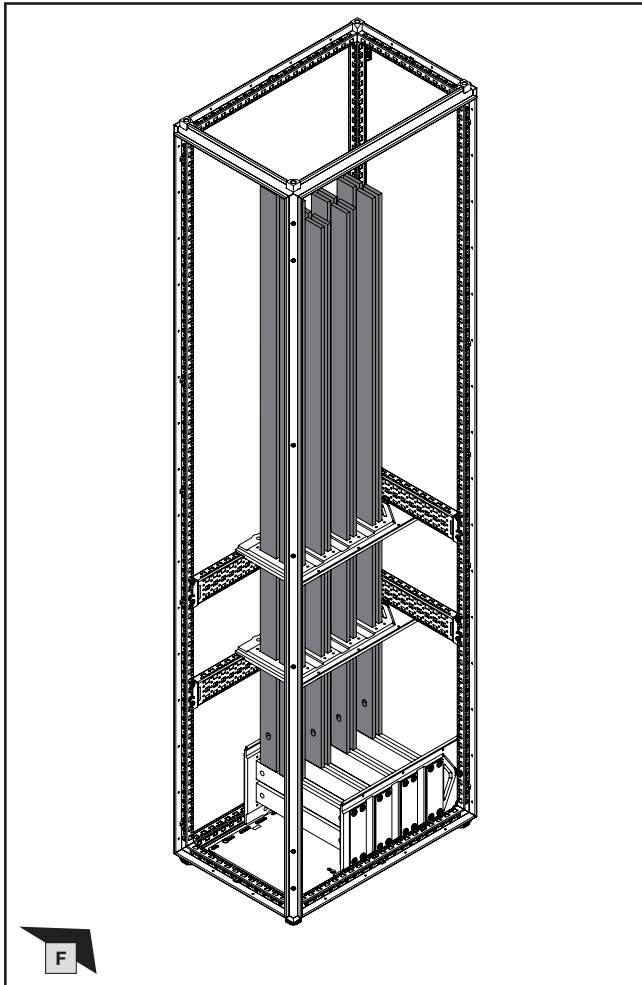

Hinweis / Note / Remarque (X)

Die Länge der Sammelschienen wird mit Hilfe der Online-Berechnungssoftware „RiPower“ im Niederspannungsschaltanlagen Konfigurator ermittelt.

The length of the busbars is determined using the online calculation software "RiPower" in the low-voltage switchgear configurator.

La longueur des jeux de barres est déterminée à l'aide du logiciel de calcul en ligne « RiPower » du configurateur de TGBT.



RiPower

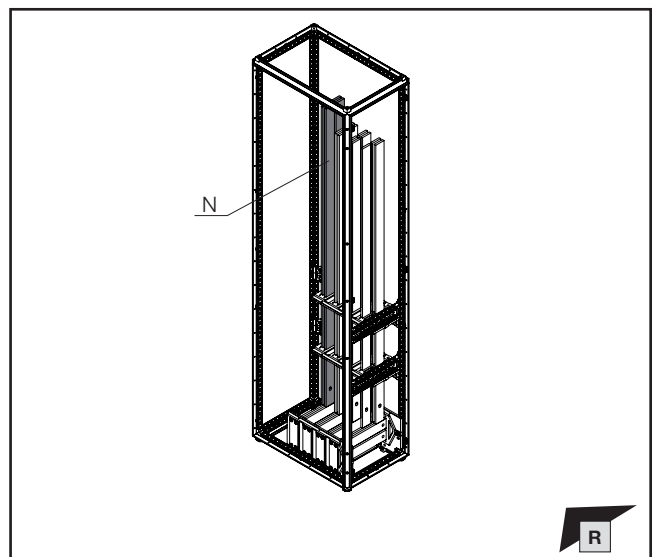

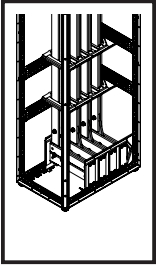

SW16/
SW17

DE EN FR



1. Montage Hochführungsfeld – Einbaulage Boden auf Rücken Mitte
1. Fitting the riser section – Mounting position: Base section via rear section in the centre
1. Montage de la zone d'installation verticale – jeux de barres dans la base à l'arrière au centre

- 1.7 Anbindung vertikales Verteilsammelschienensystem
- 1.7 Connecting the vertical multi-terminal busbar system
- 1.7 Connexion aux jeux de barres de distribution verticaux

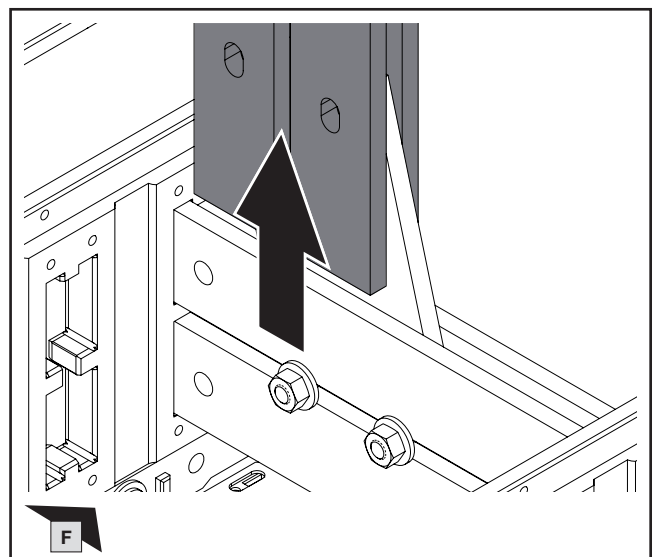
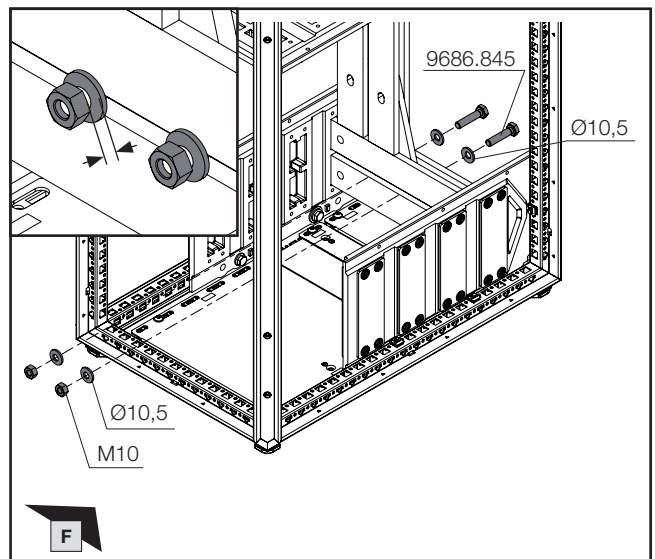
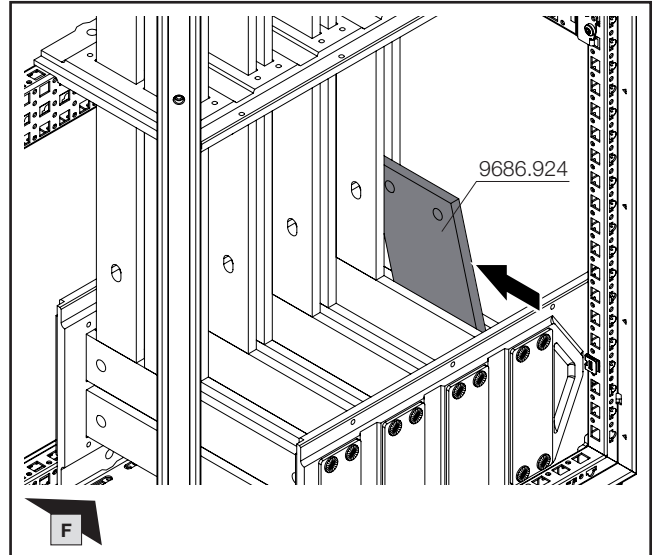
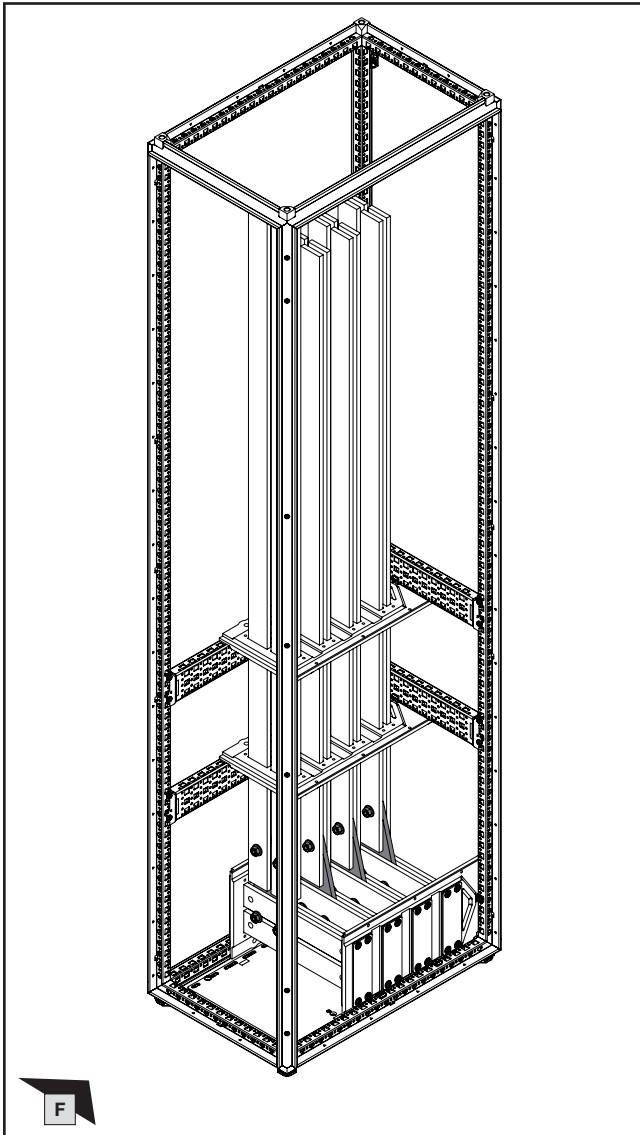

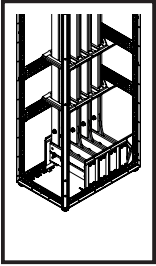

SW16/
SW17

DE EN FR



1. Montage Hochführungsfeld – Einbaulage Boden auf Rücken Mitte
1. Fitting the riser section – Mounting position: Base section via rear section in the centre
1. Montage de la zone d'installation verticale – jeux de barres dans la base à l'arrière au centre

- 1.7 Anbindung vertikales Verteilsammelschienensystem
- 1.7 Connecting the vertical multi-terminal busbar system
- 1.7 Connexion aux jeux de barres de distribution verticaux

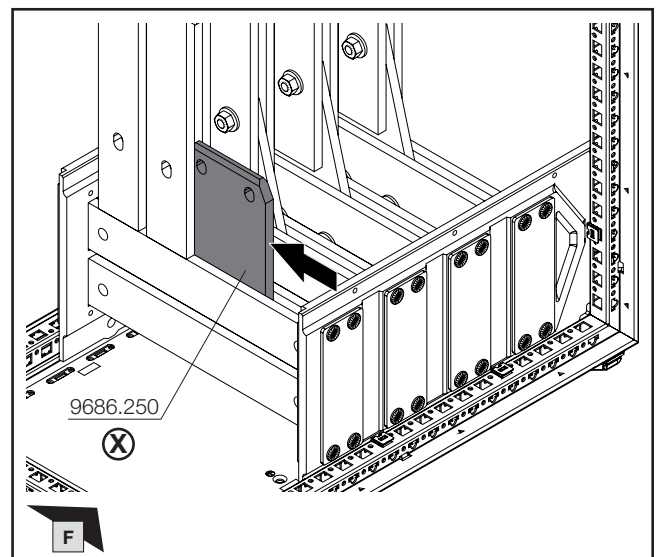
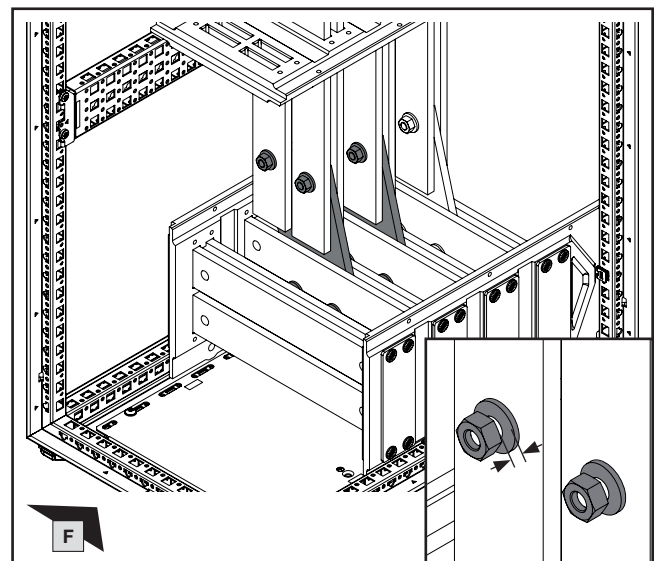
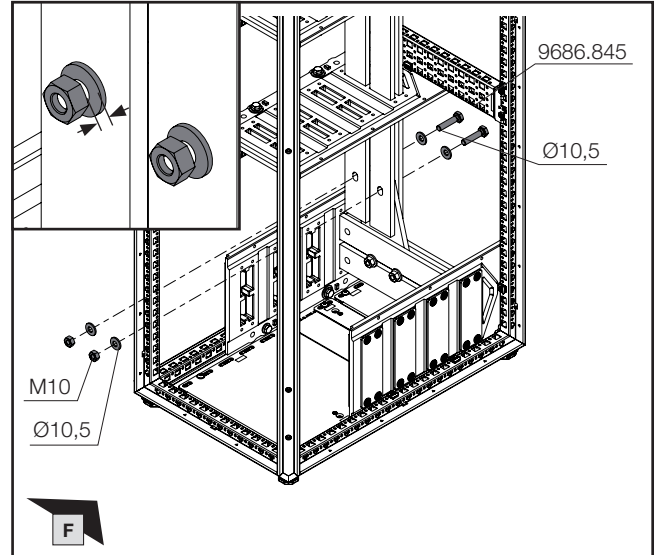
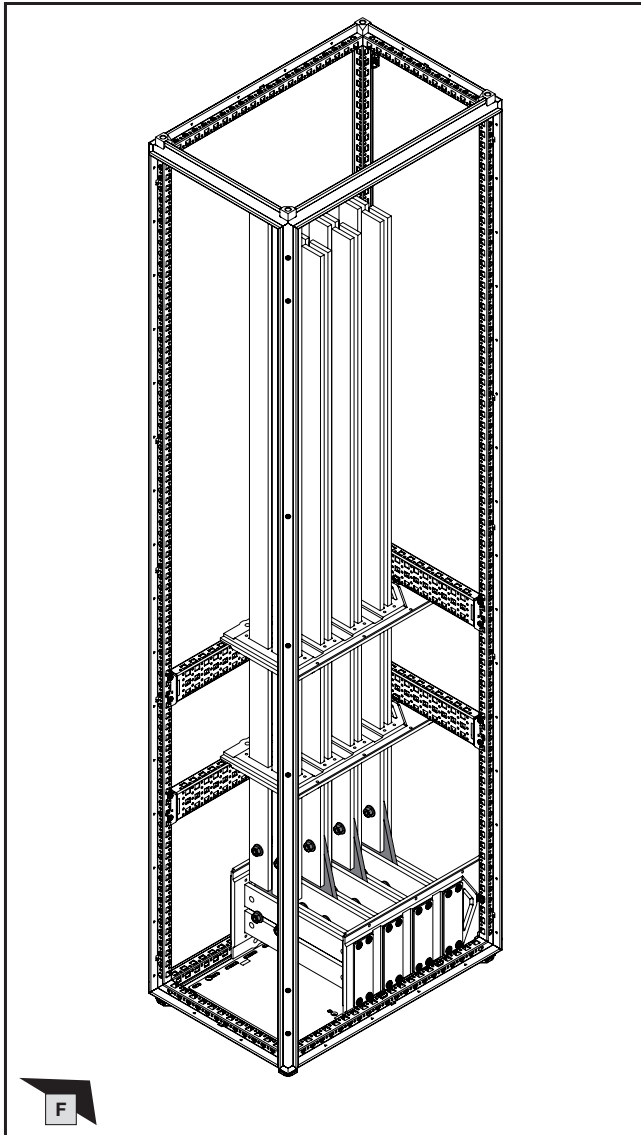

Hinweis / Note / Remarque (X)

Längsverbinder und vertikale Schienen nur bei separat im Dach geführtem N/PEN (siehe Kapitel 1.1).

Longitudinal connectors and vertical rails only with N/PEN routed separately in the roof (see chapter 1.1).

Éléments de jonction longitudinaux et barres verticales uniquement avec N/PEN qui chemine séparément sous le toit (voir chapitre 1.1).

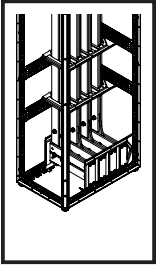

SW16/
SW17



1. Montage Hochführungsfeld – Einbaulage Boden auf Rücken Mitte
1. Fitting the riser section – Mounting position: Base section via rear section in the centre
1. Montage de la zone d'installation verticale – jeux de barres dans la base à l'arrière au centre

- 1.7 Anbindung vertikales Verteilsammelschienensystem
- 1.7 Connecting the vertical multi-terminal busbar system
- 1.7 Connexion aux jeux de barres de distribution verticaux

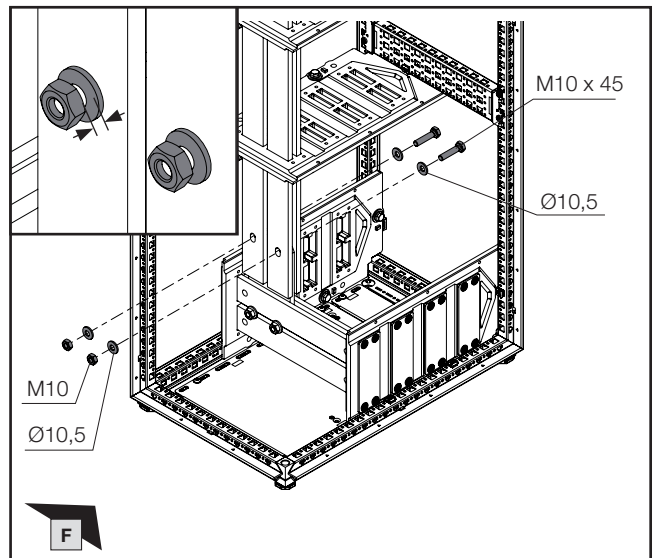
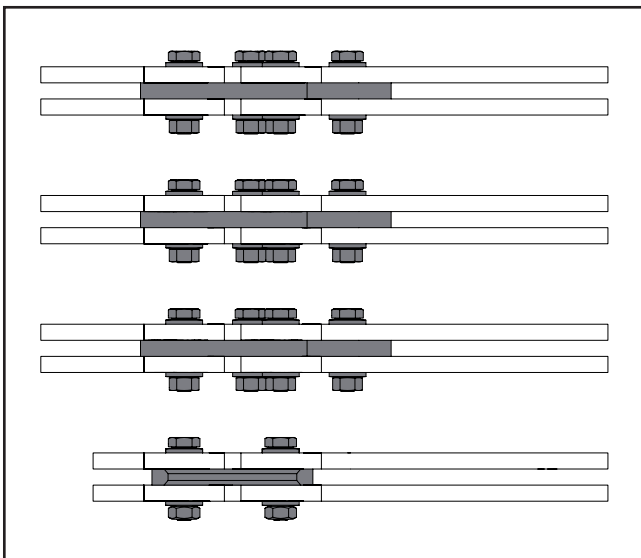
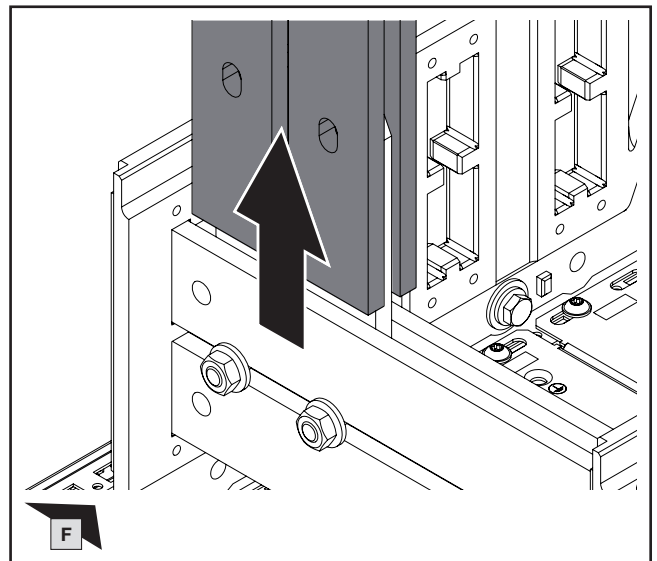
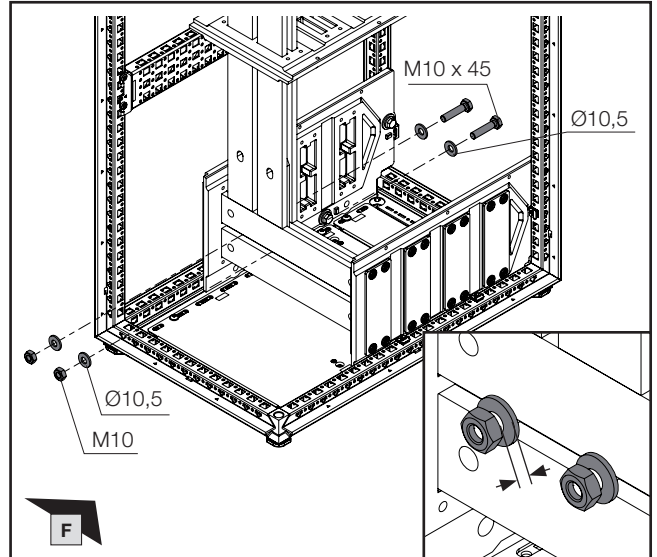
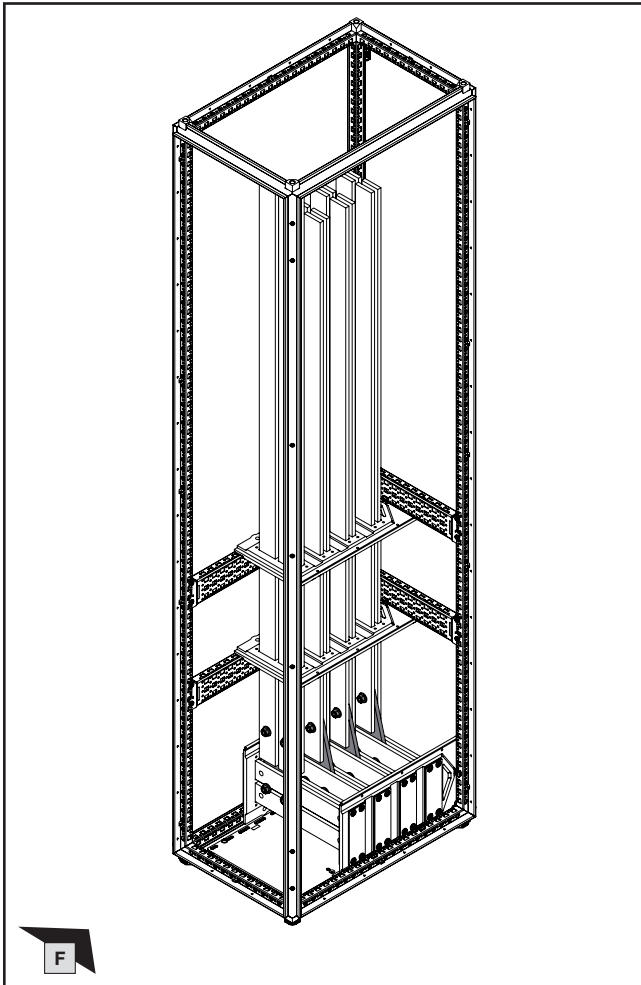

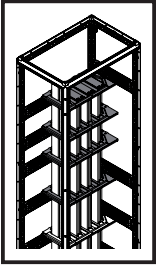

1. Montage Hochführungsfeld – Einbaulage Boden auf Rücken Mitte
1. Fitting the riser section – Mounting position: Base section via rear section in the centre
1. Montage de la zone d'installation verticale – jeux de barres dans la base à l'arrière au centre

- 1.8 Montage obere System-Chassis und Sammelschienenhalter
- 1.8 Fitting the upper punched sections with mounting flanges and busbar supports
- 1.8 Montage des rails de montage supérieurs et des supports de jeux de barres

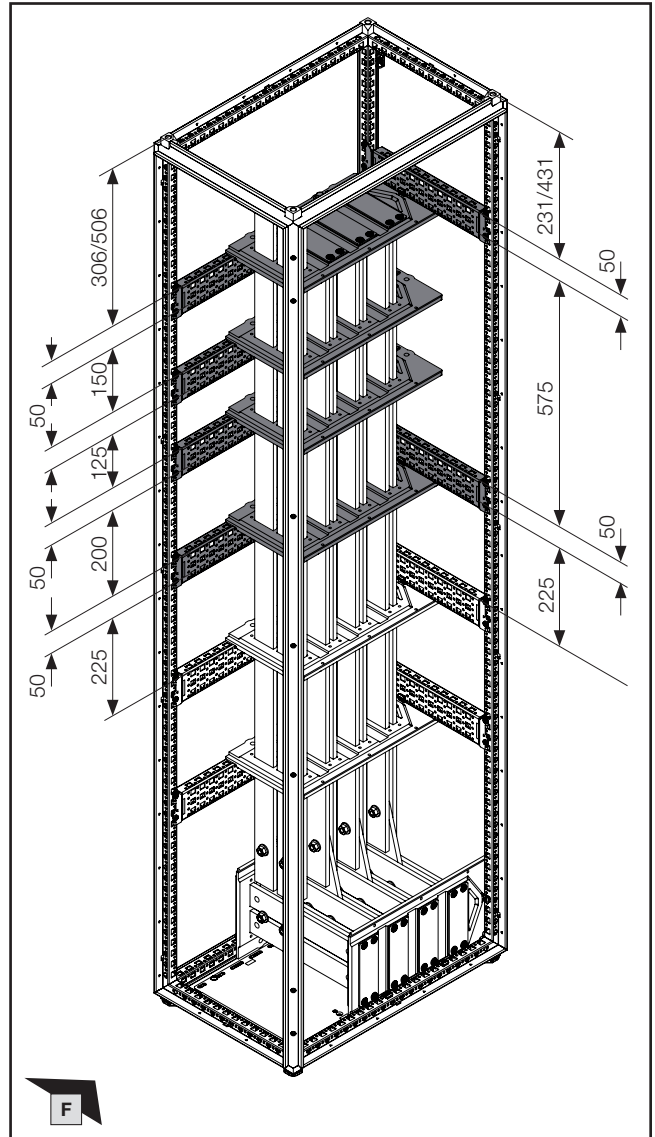
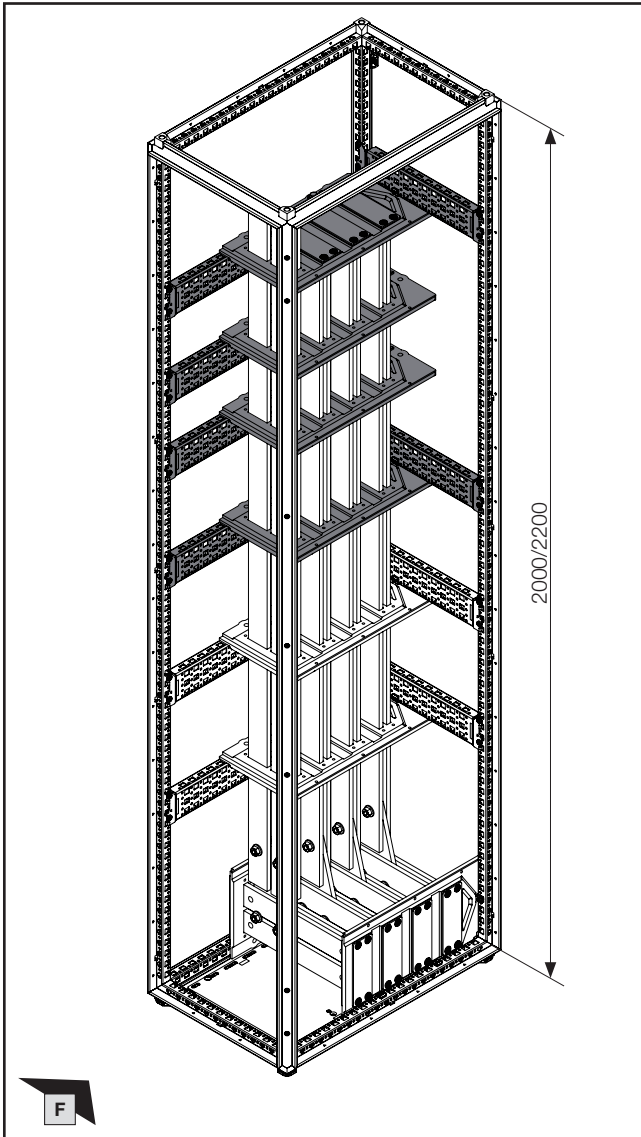

Hinweis / Note / Remarque

Bei erschwelter Montage Befestigungsschrauben der Sammelschienenhalter lösen und zum Abschluss des Montageschritts anziehen.

If fitting is difficult, loosen the assembly screws of the busbar supports and tighten them at the end of this step.

En cas de difficulté de montage, desserrer les vis de fixation des supports de jeux de barres et les resserrer en fin de montage.



Hinweis / Note / Remarque

Die Reihenfolge der Montage auf den nächsten drei Seiten ist schrittweise zu befolgen.

The assembly sequence on the next three pages must be followed step by step.

L'ordre de montage sur les trois prochaines pages doit être respecté étape par étape.

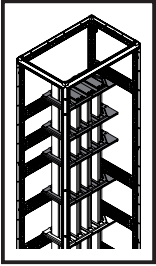

- 1. Montage Hochführungsfeld – Einbaulage Boden auf Rücken Mitte
- 1. Fitting the riser section – Mounting position: Base section via rear section in the centre
- 1. Montage de la zone d'installation verticale – jeux de barres dans la base à l'arrière au centre

- 1.8 Montage obere System-Chassis und Sammelschienehalter
- 1.8 Fitting the upper punched sections with mounting flanges and busbar supports
- 1.8 Montage des rails de montage supérieurs et des supports de jeux de barres

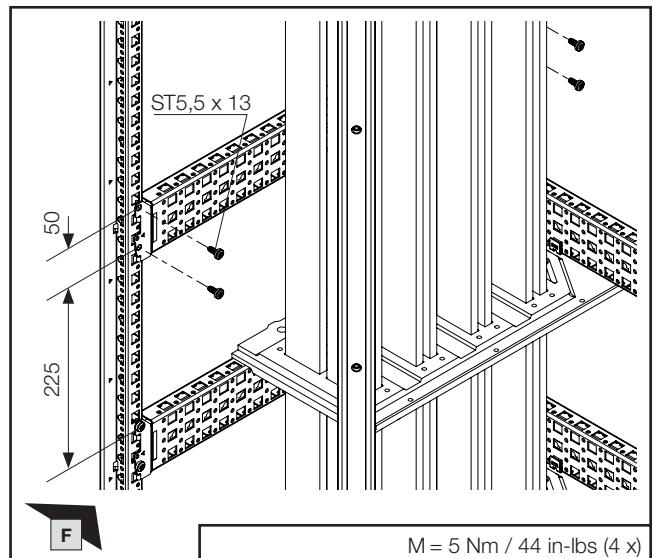
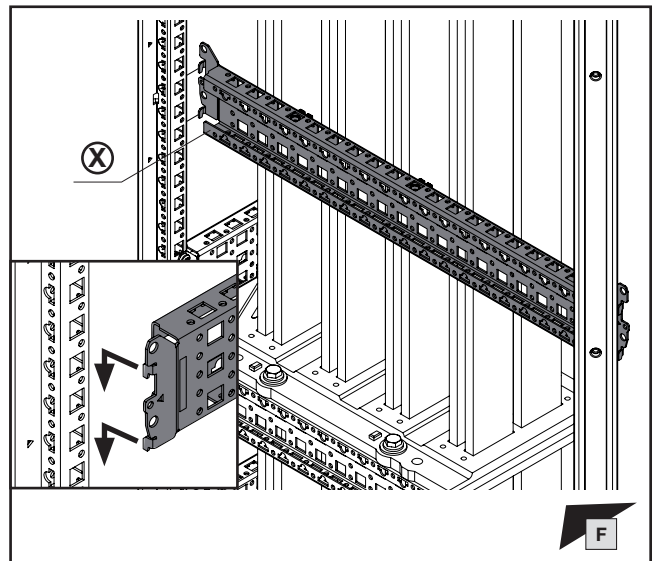
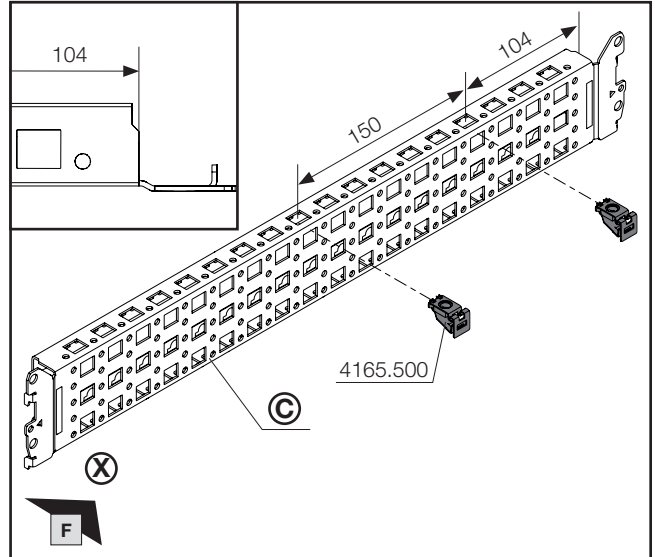
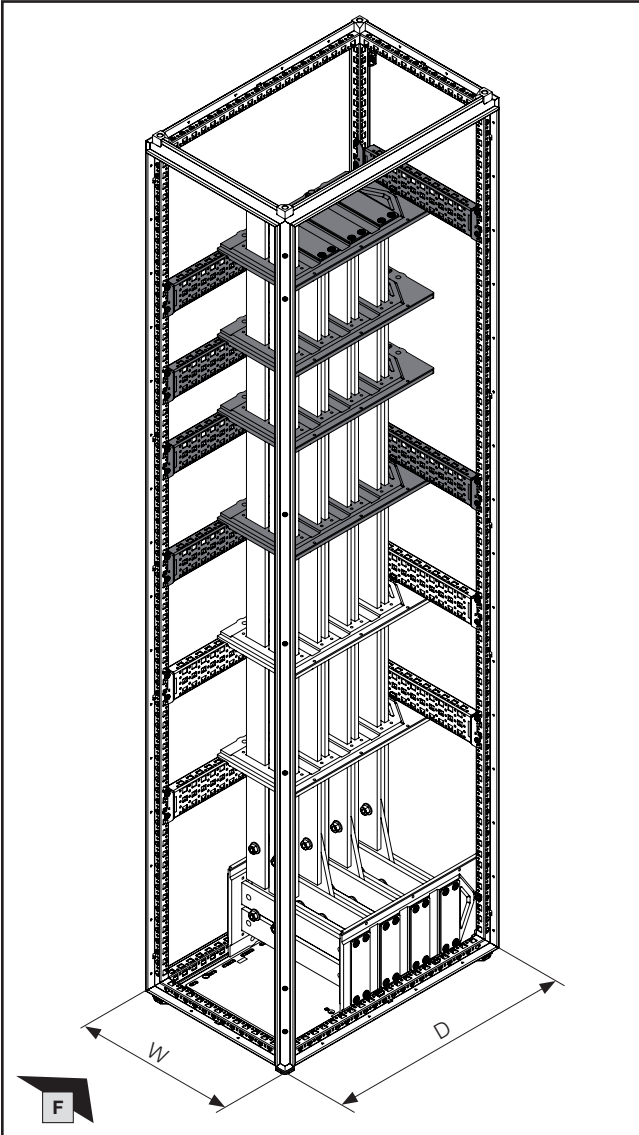

D mm	W mm	Best.-Nr. Model No. Référence
x	400	8617.110
600	x	8617.130
800	x	8617.140

M = 5 Nm / 44 in-lbs (4 x)

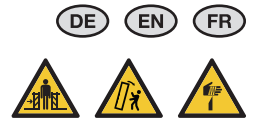
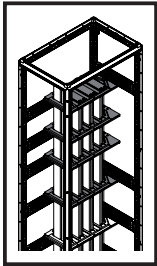

- 1. Montage Hochführungsfeld – Einbaulage Boden auf Rücken Mitte
- 1. Fitting the riser section – Mounting position: Base section via rear section in the centre
- 1. Montage de la zone d'installation verticale – jeux de barres dans la base à l'arrière au centre

- 1.8 Montage obere System-Chassis und Sammelschienehalter
- 1.8 Fitting the upper punched sections with mounting flanges and busbar supports
- 1.8 Montage des rails de montage supérieurs et des supports de jeux de barres

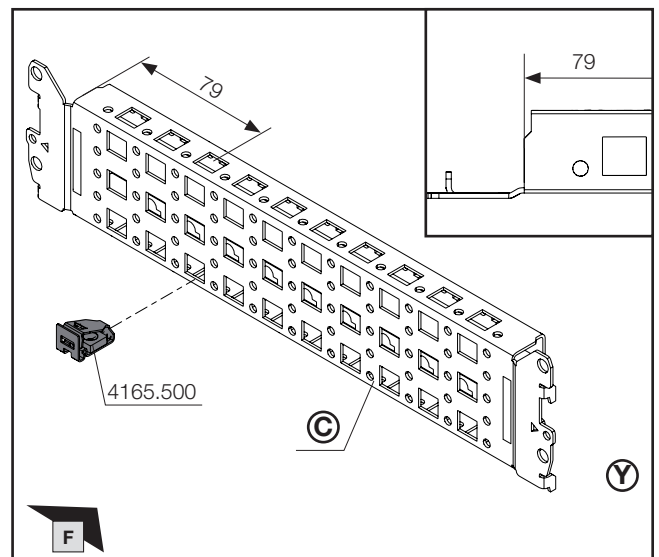
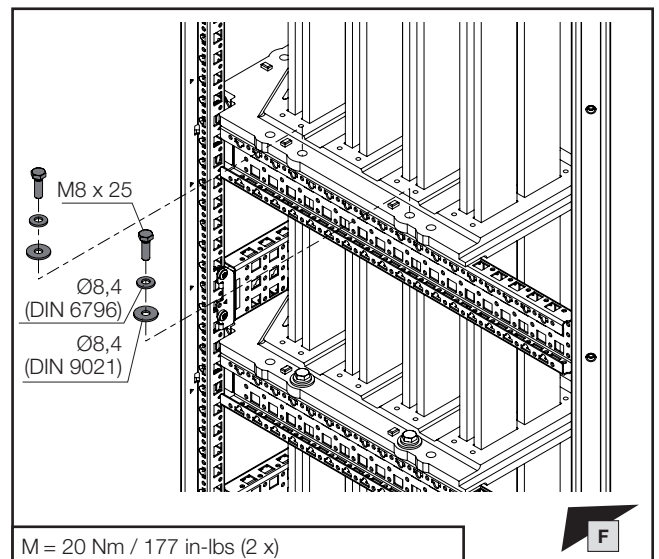
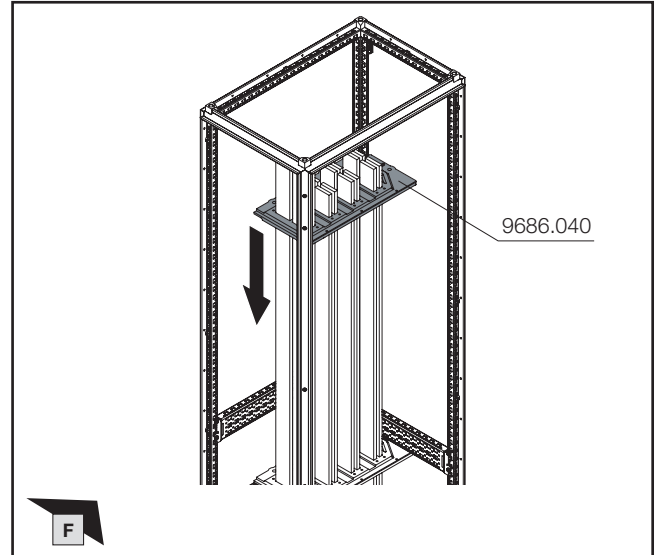
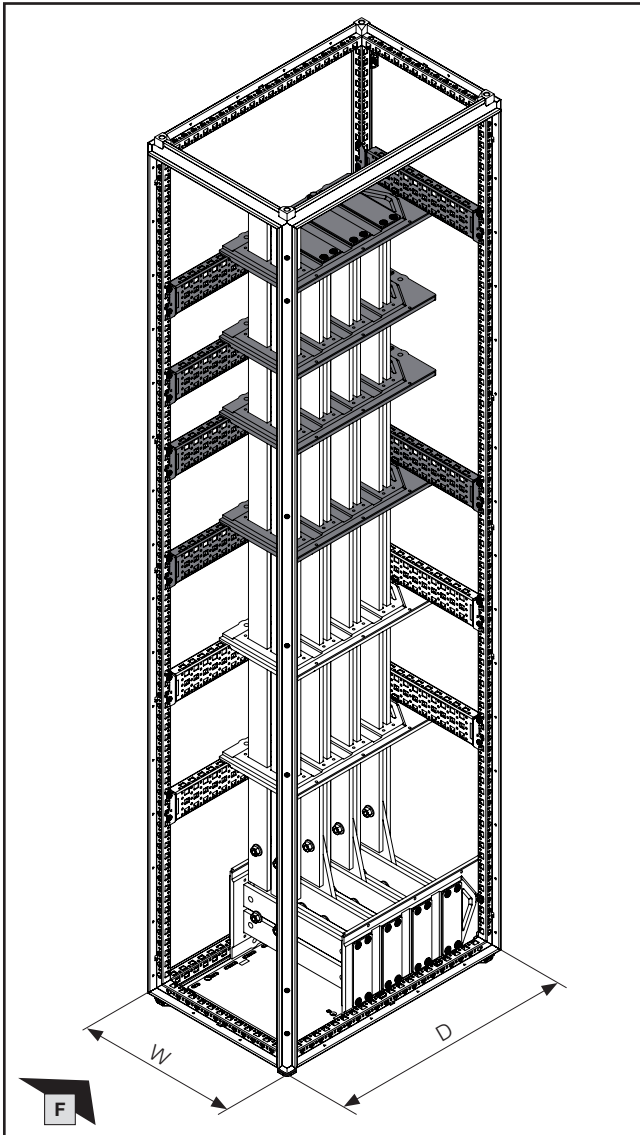

D mm	W mm	Best.-Nr. Model No. Référence
x	400	8617.110
600	x	8617.130
800	x	8617.140

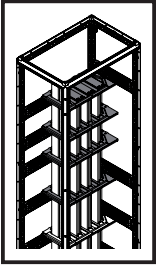

- 1. Montage Hochführungsfeld – Einbaulage Boden auf Rücken Mitte
- 1. Fitting the riser section – Mounting position: Base section via rear section in the centre
- 1. Montage de la zone d'installation verticale – jeux de barres dans la base à l'arrière au centre

- 1.8 Montage obere System-Chassis und Sammelschienehalter
- 1.8 Fitting the upper punched sections with mounting flanges and busbar supports
- 1.8 Montage des rails de montage supérieurs et des supports de jeux de barres

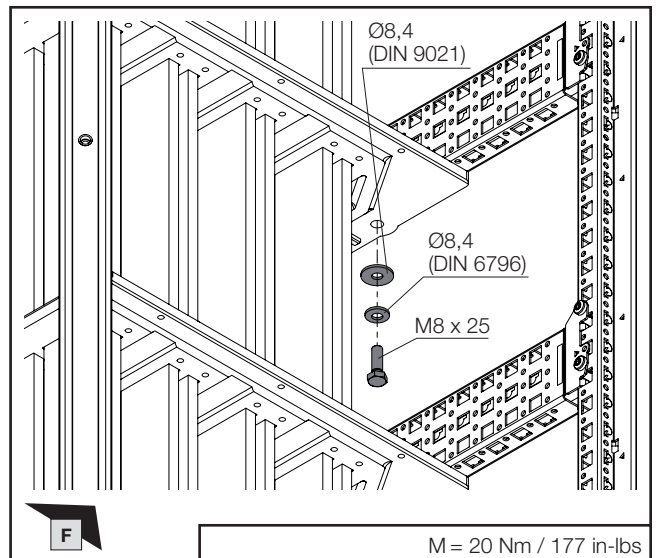
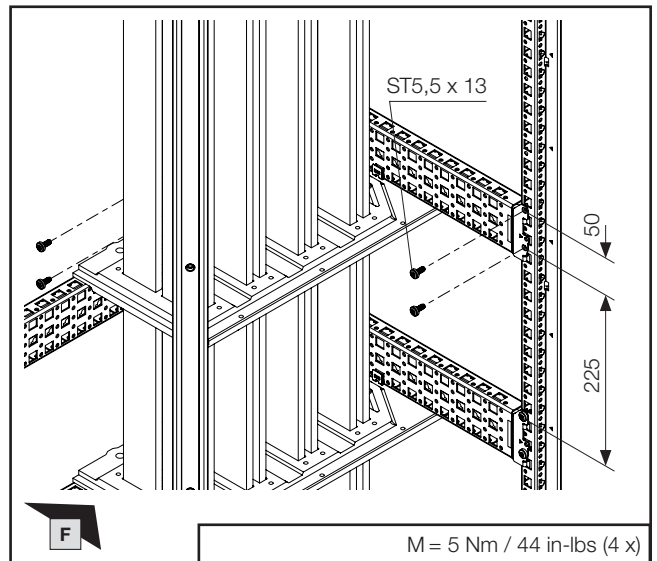
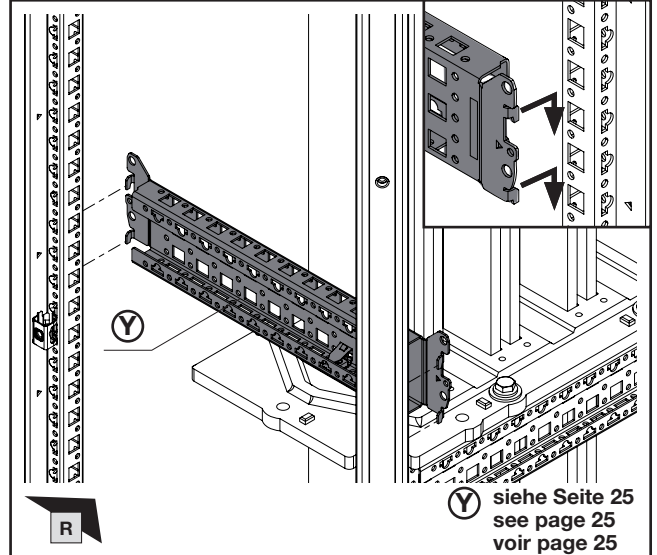
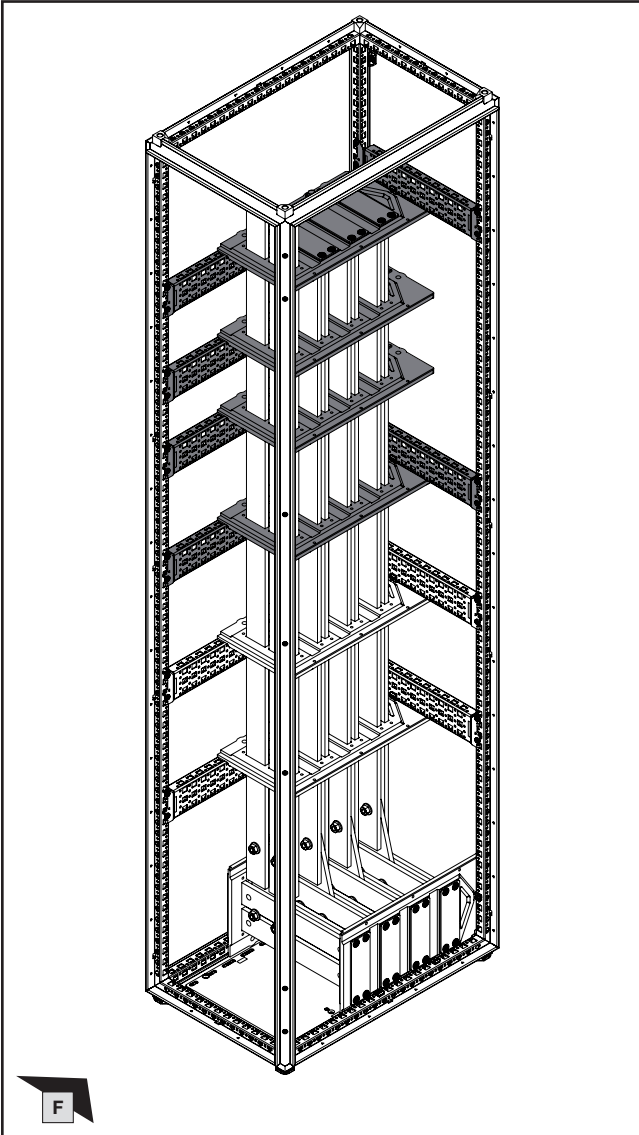

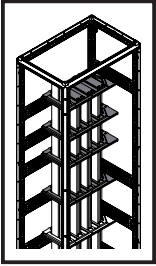

1. Montage Hochführungsfeld – Einbaulage Boden auf Rücken Mitte
1. Fitting the riser section – Mounting position: Base section via rear section in the centre
1. Montage de la zone d'installation verticale – jeux de barres dans la base à l'arrière au centre

- 1.8 Montage obere System-Chassis und Sammelschienehalter
- 1.8 Fitting the upper punched sections with mounting flanges and busbar supports
- 1.8 Montage des rails de montage supérieurs et des supports de jeux de barres

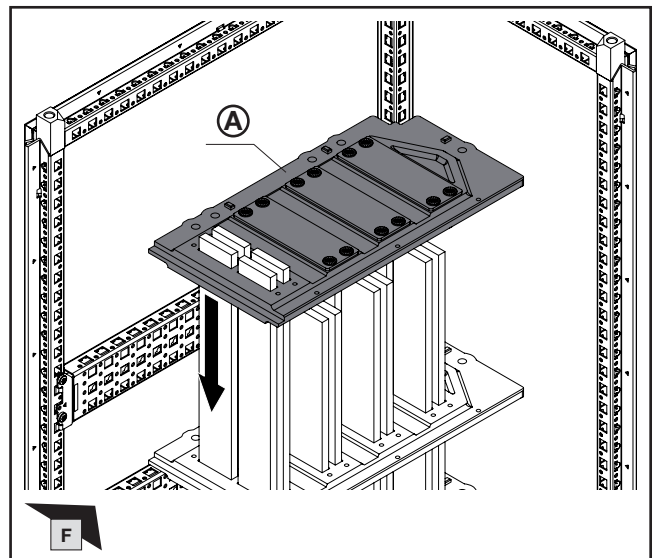
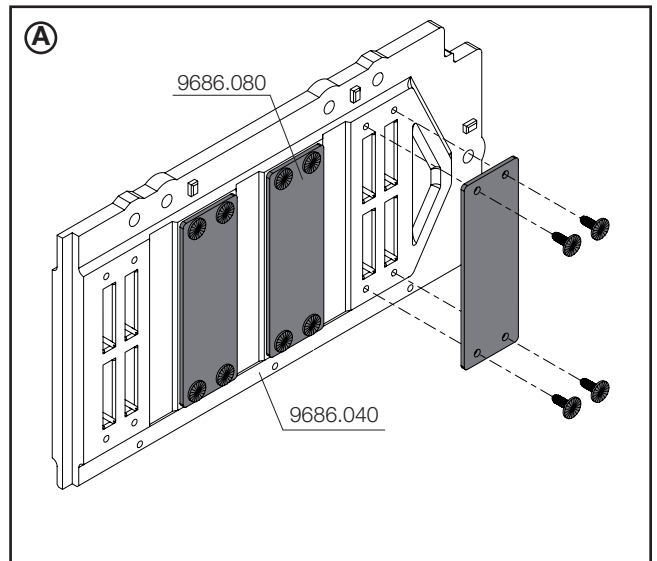
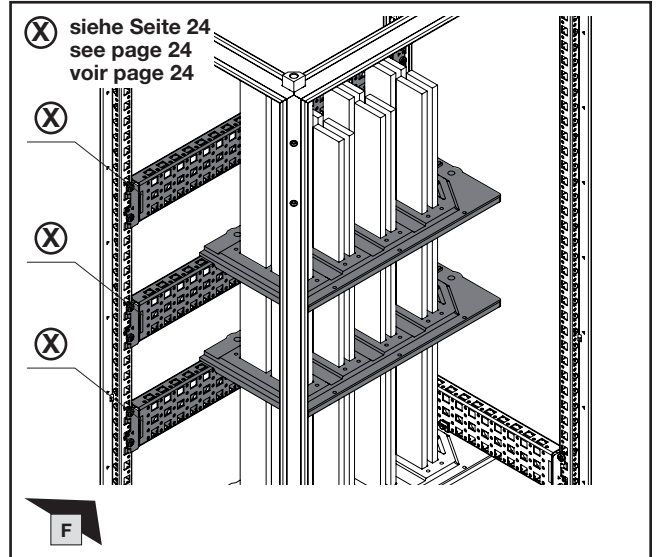
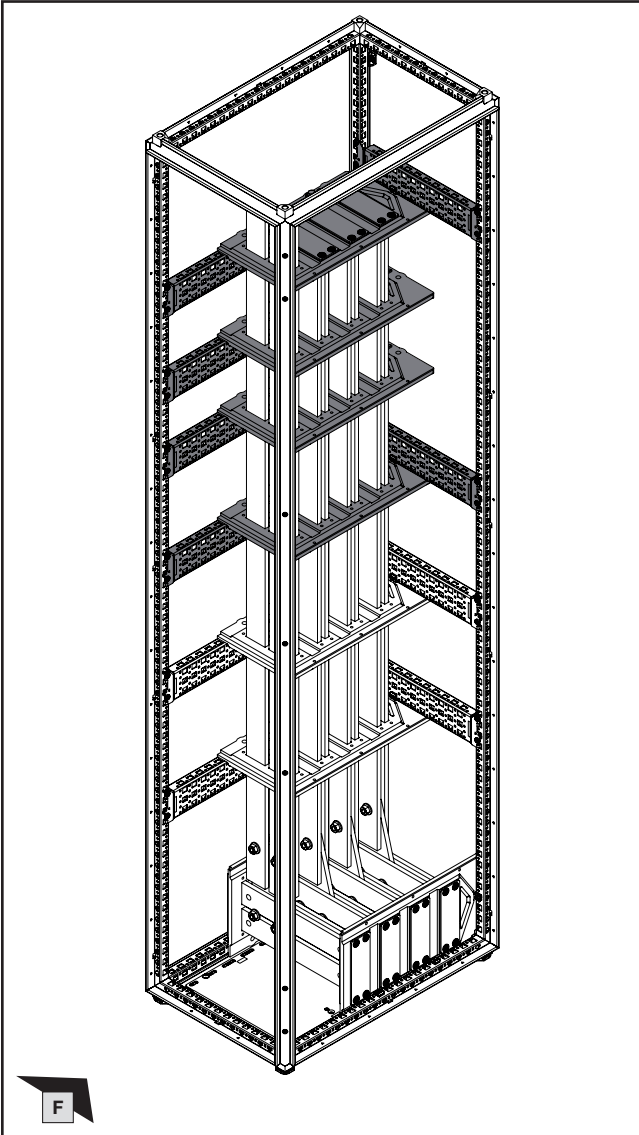

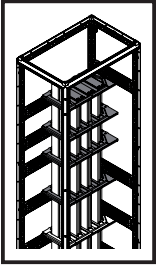

- 1. Montage Hochführungsfeld – Einbaulage Boden auf Rücken Mitte
- 1. Fitting the riser section – Mounting position: Base section via rear section in the centre
- 1. Montage de la zone d'installation verticale – jeux de barres dans la base à l'arrière au centre

- 1.8 Montage obere System-Chassis und Sammelschienenhalter
- 1.8 Fitting the upper punched sections with mounting flanges and busbar supports
- 1.8 Montage des rails de montage supérieurs et des supports de jeux de barres

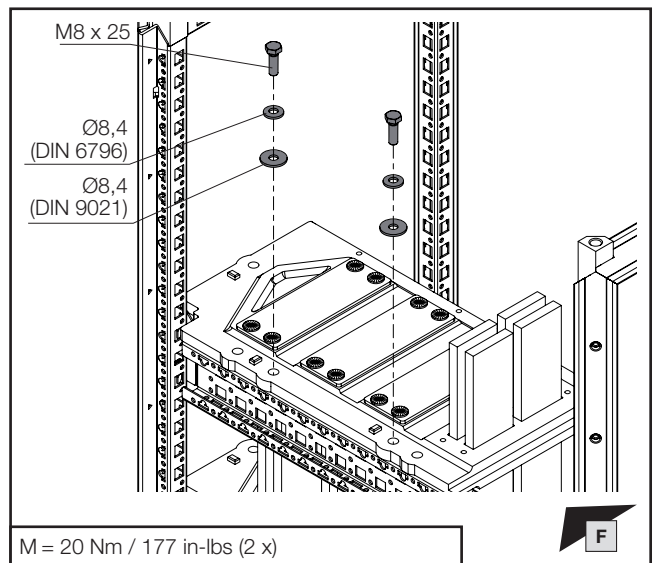
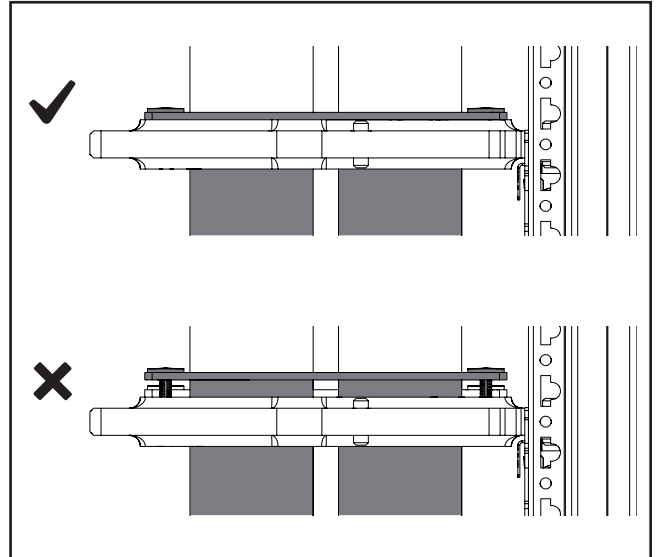
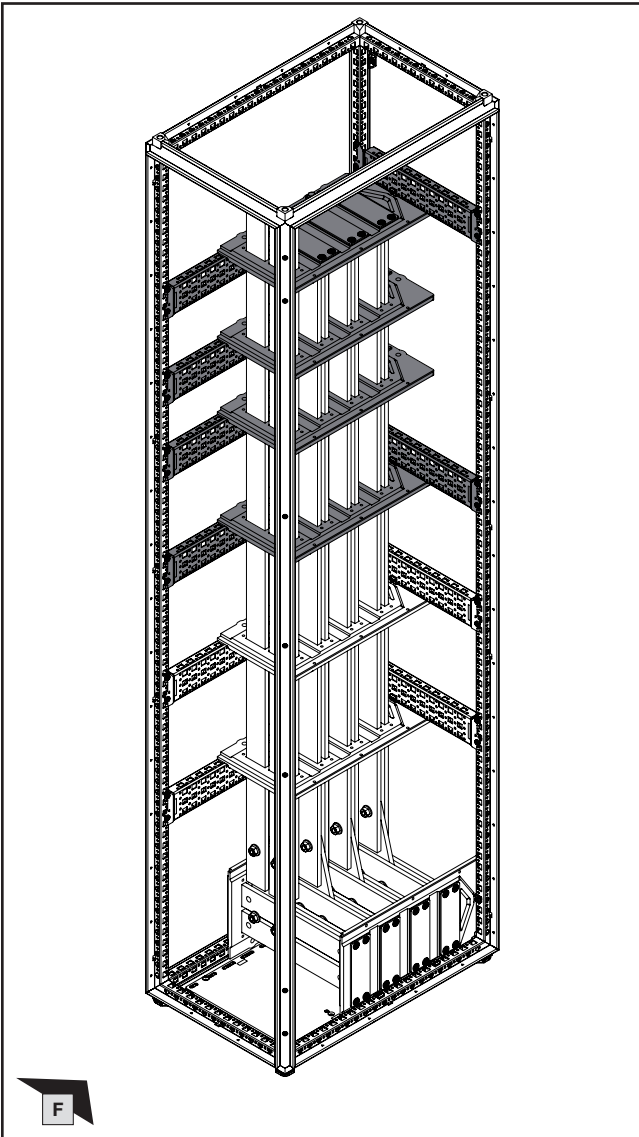

M = 20 Nm / 177 in-lbs (2 x)

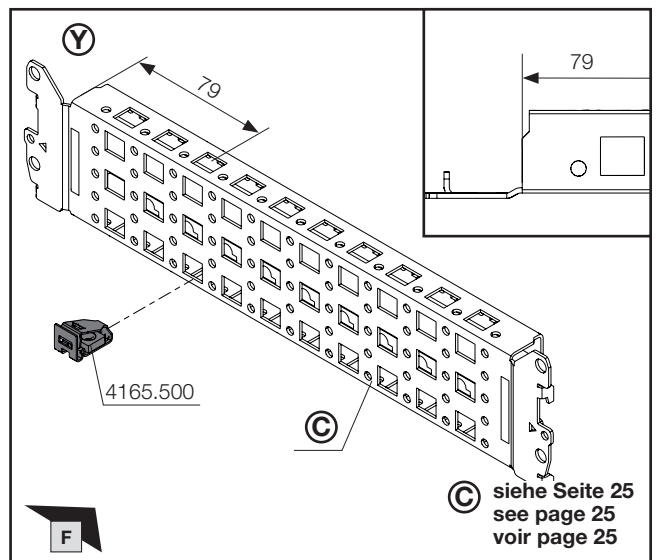
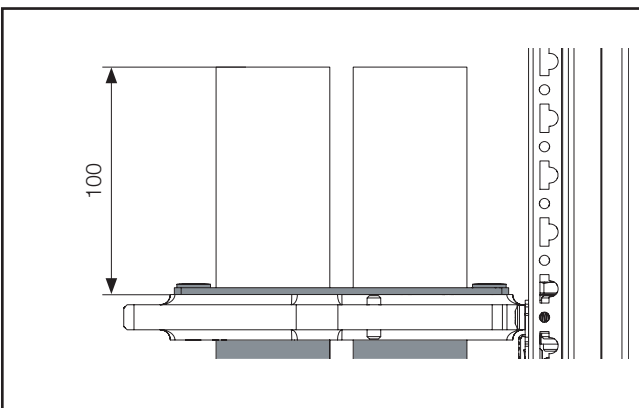

© siehe Seite 25
see page 25
voir page 25



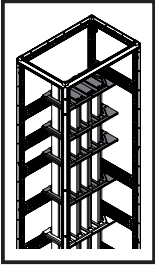

TX30



SW13



DE EN FR



1. Montage Hochführungsfeld – Einbaulage Boden auf Rücken Mitte
1. Fitting the riser section – Mounting position: Base section via rear section in the centre
1. Montage de la zone d'installation verticale – jeux de barres dans la base à l'arrière au centre

- 1.8 Montage obere System-Chassis und Sammelschienehalter
- 1.8 Fitting the upper punched sections with mounting flanges and busbar supports
- 1.8 Montage des rails de montage supérieurs et des supports de jeux de barres

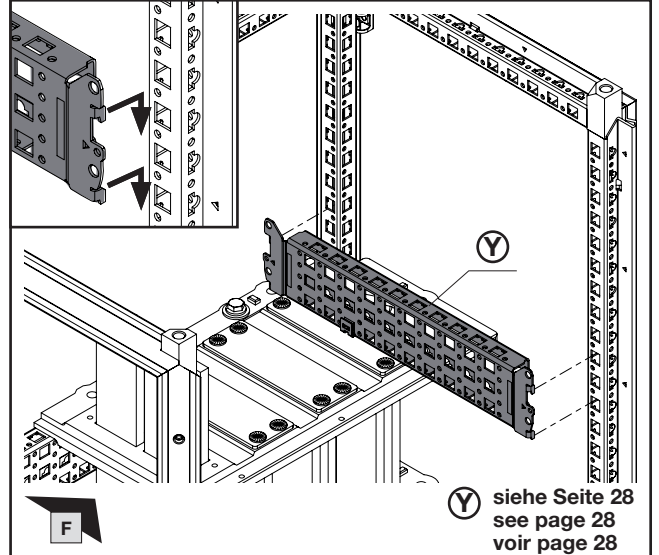
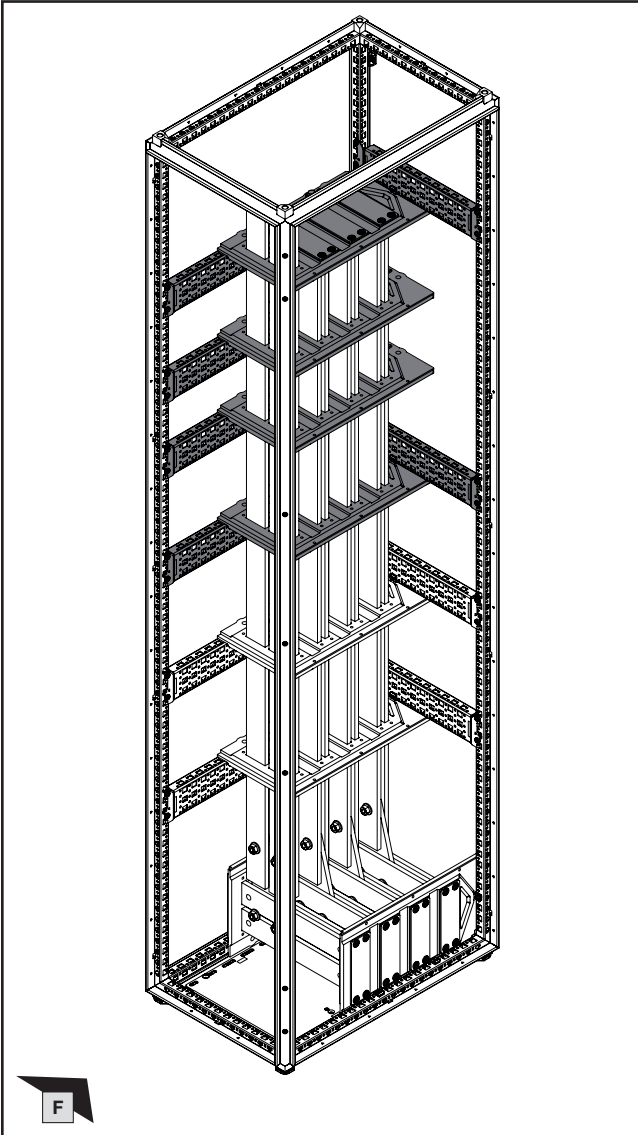

Y siehe Seite 28
see page 28
voir page 28

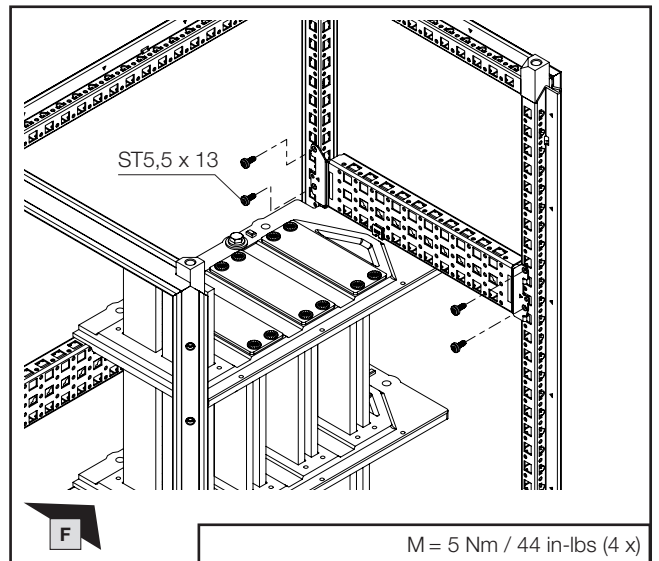

ST5,5 x 13

M = 5 Nm / 44 in-lbs (4 x)

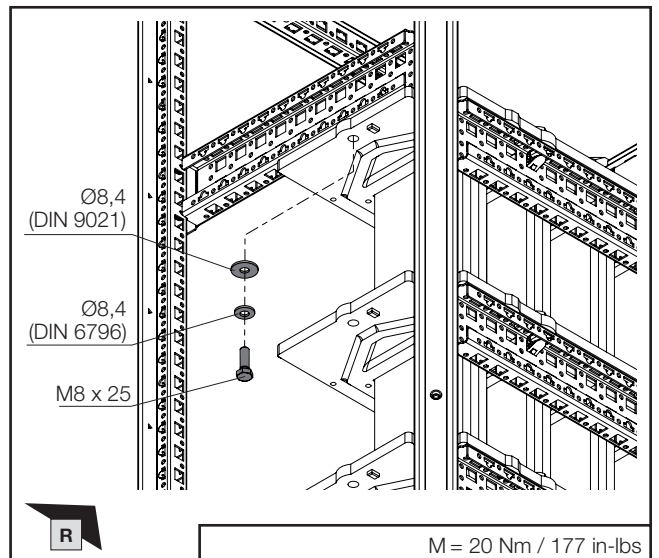

Ø8,4
(DIN 9021)

Ø8,4
(DIN 6796)

M8 x 25

M = 20 Nm / 177 in-lbs

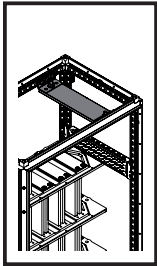

- 1. Montage Hochführungsfeld – Einbaulage Boden auf Rücken Mitte
- 1. Fitting the riser section – Mounting position: Base section via rear section in the centre
- 1. Montage de la zone d'installation verticale – jeux de barres dans la base à l'arrière au centre

- 1.9 Montage des PE-/PEN-Sammelschienensystems
- 1.9 Fitting the PE/PEN busbar system
- 1.9 Montage des jeux de barres Terre / Terre-Neutre

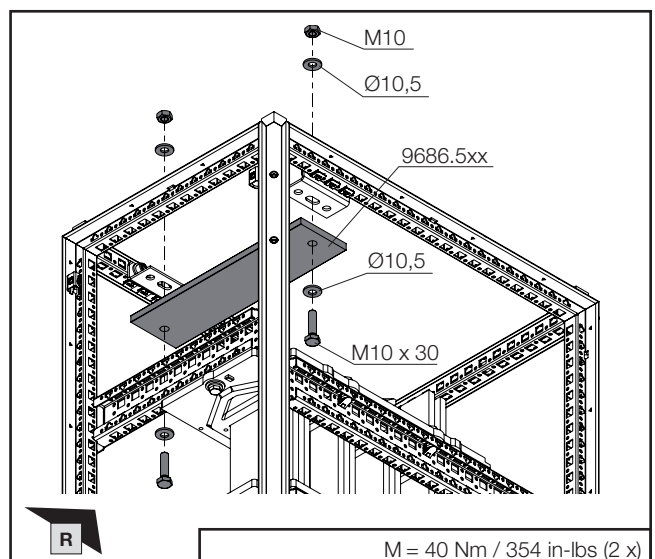
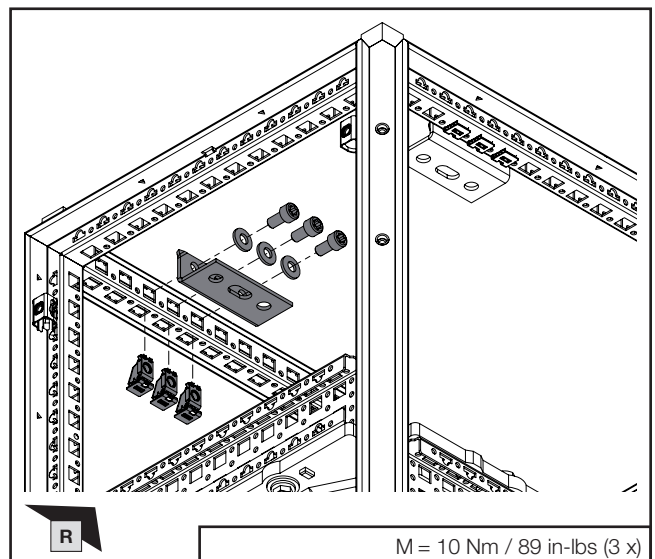
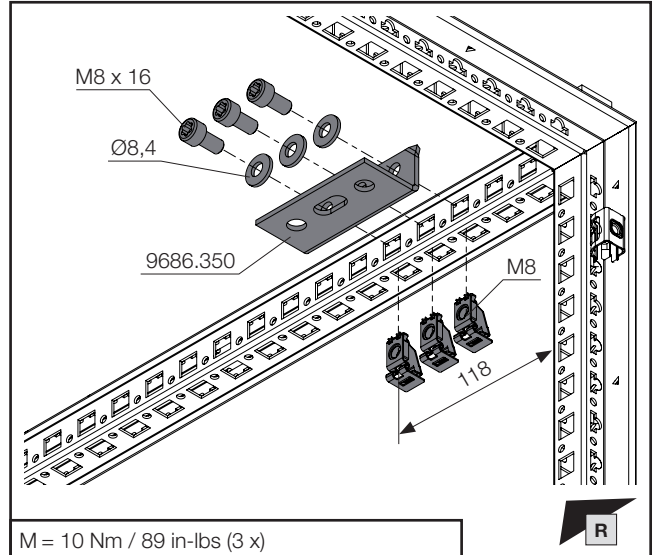
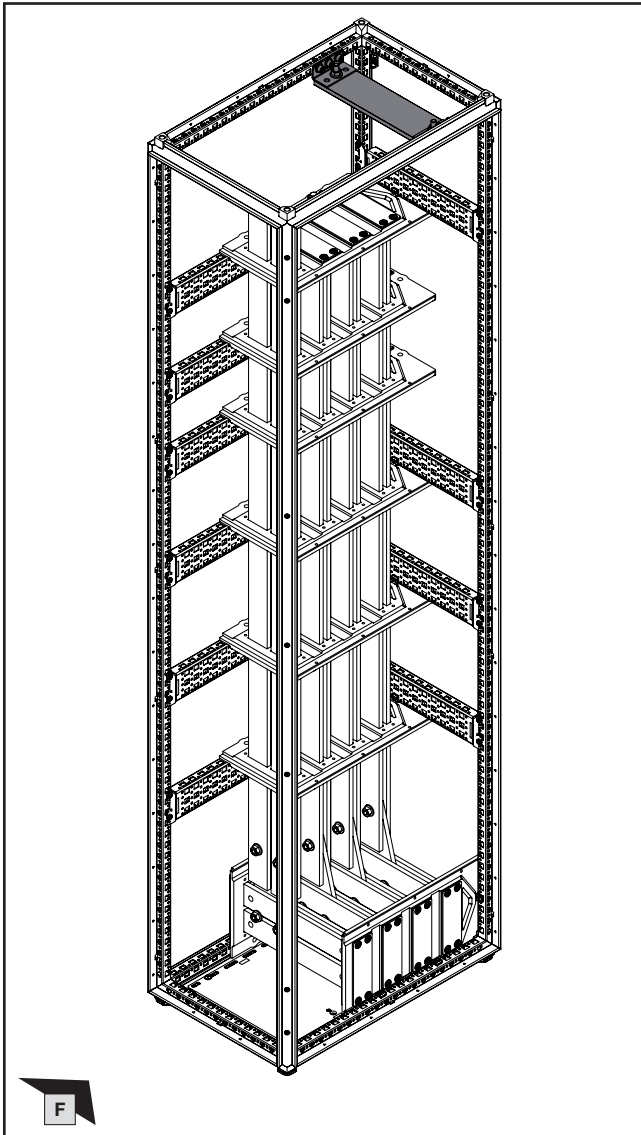

Montageanleitung VX25 Ri4Power – Schalt- und Energieverteilanlagen-System

Assembly instructions VX25 Ri4Power – Switchgear and power distribution system

Notice de montage VX25 Ri4Power – Distribution de courant

DE/EN/FR

Schranksystem VX25 – Technische Dokumentation – Schutzleiteranschluss, Strombelastbarkeit

VX25 Enclosure System – Technical documentation – PE conductor connection, current carrying capacity

Armoires électriques VX25 – Manuel technique – Raccordement de mise à la terre et intensités maximales admissibles

DE EN FR

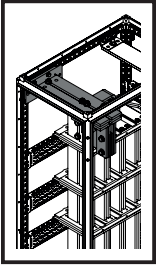

1. Montage Hochführungsfeld – Einbaulage Boden auf Rücken Mitte
1. Fitting the riser section – Mounting position: Base section via rear section in the centre
1. Montage de la zone d'installation verticale – jeux de barres dans la base à l'arrière au centre

- 1.10 Montage des N-Sammelschienensystems
- 1.10 Fitting the N busbar system
- 1.10 Montage des jeux de barres Neutre

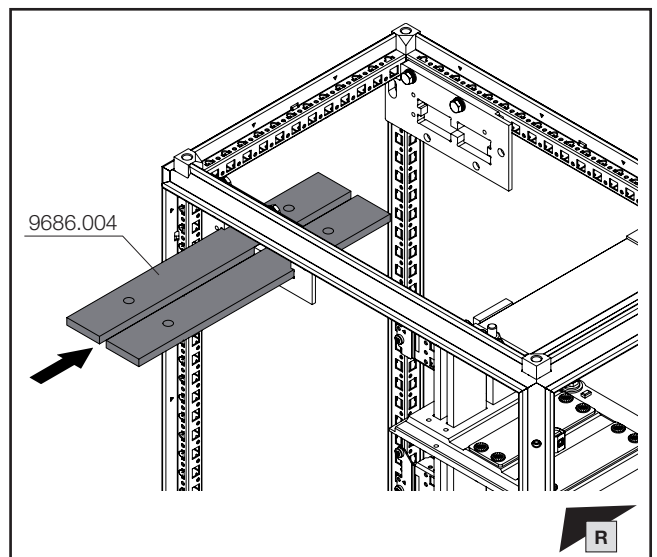
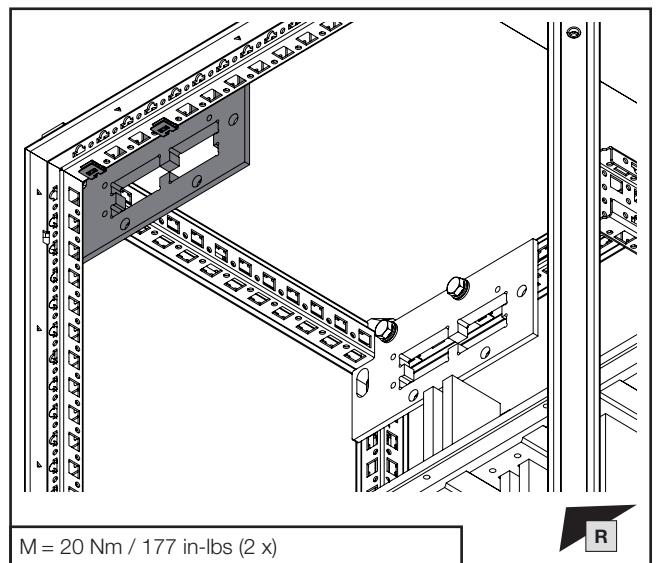
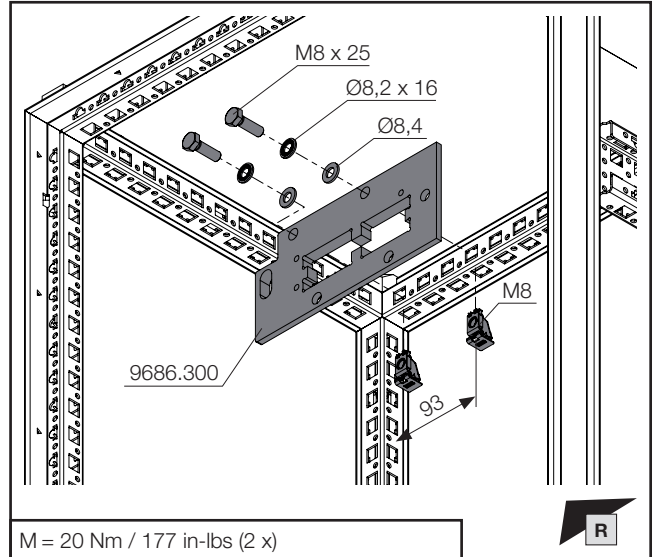
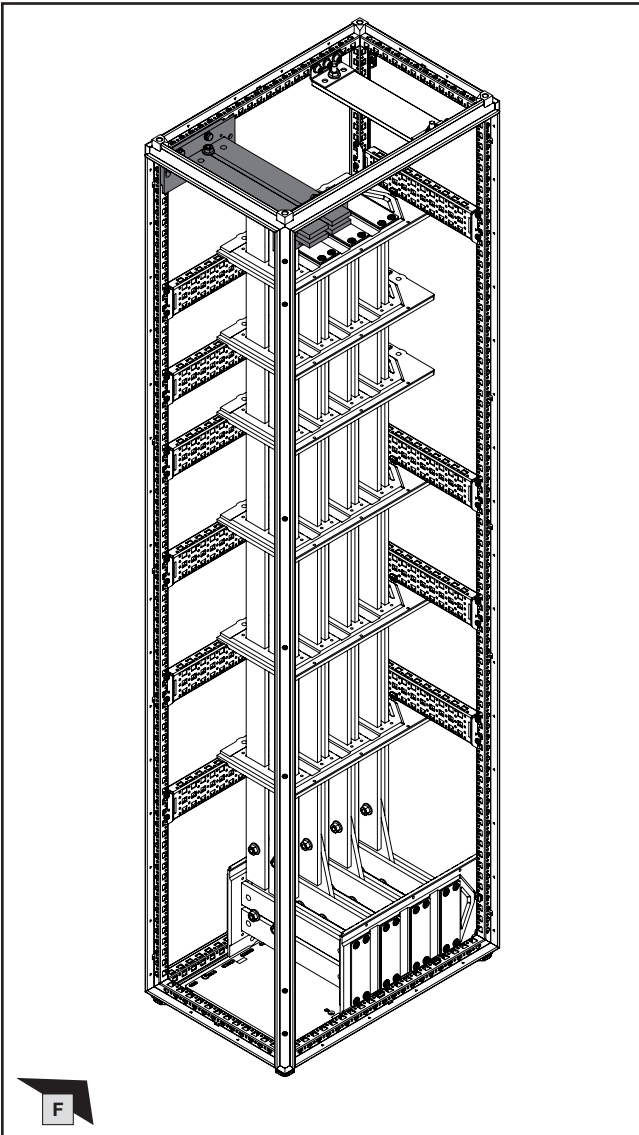

Montageanleitung VX25 Ri4Power – Schalt- und Energieverteilanlagen-System

Assembly instructions VX25 Ri4Power – Switchgear and power distribution system

Notice de montage VX25 Ri4Power – Distribution de courant

DE/EN/FR



Hinweis / Note / Remarque

Besonderheit 2 x 50 x 10 N-Sammelschiene: siehe Kapitel 5

Particular feature – 2 x 50 x 10 N busbar: see chapter 5

Caractéristiques particulières – jeu de barres Neutre avec 2 barres de courant 50 x 10 : voir chapitre 5

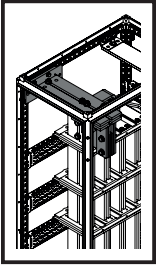

SW16/
SW17



1. Montage Hochführungsfeld – Einbaulage Boden auf Rücken Mitte
1. Fitting the riser section – Mounting position: Base section via rear section in the centre
1. Montage de la zone d'installation verticale – jeux de barres dans la base à l'arrière au centre

- 1.10 Montage des N-Sammelschienensystems
- 1.10 Fitting the N busbar system
- 1.10 Montage des jeux de barres Neutre

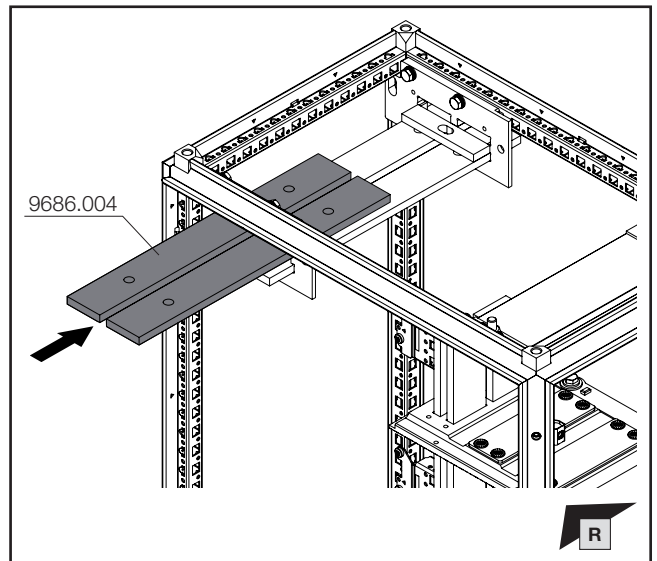
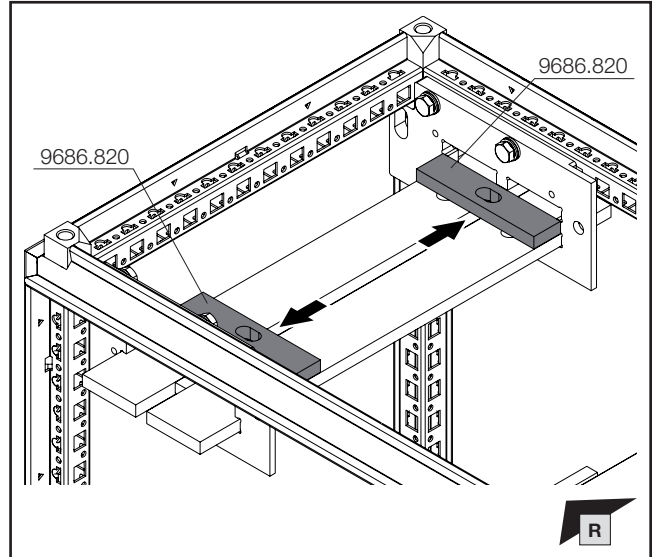
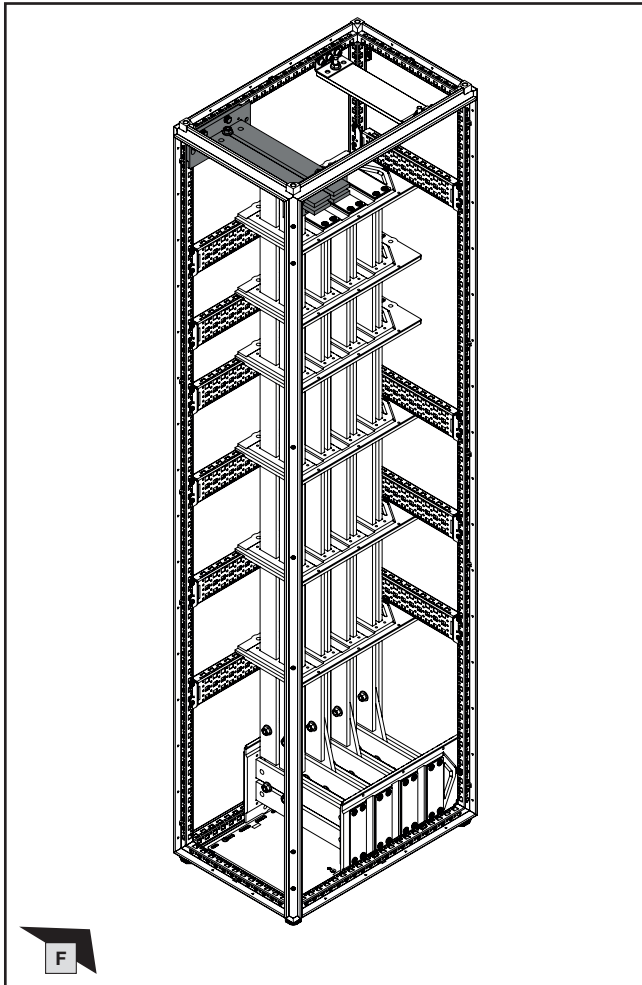

Anzahl N-Sammelschienen Quantity N busbars Nombre des jeux de barres Neutre	(A) Best.-Nr. Model No. Référence
2	9686.830
4	9686.845

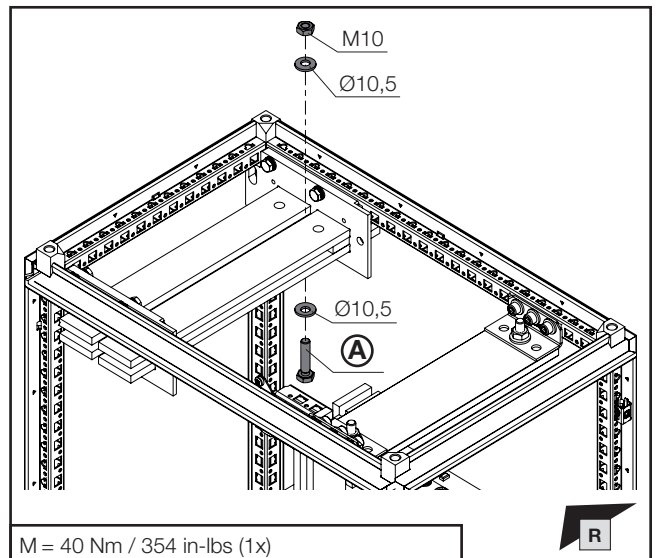
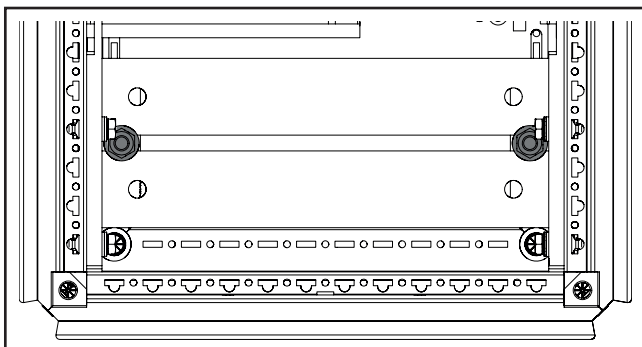

M = 40 Nm / 354 in-lbs (1x)

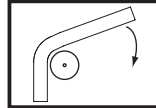
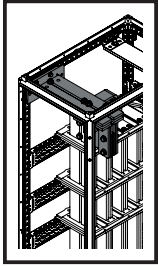

1. Montage Hochführungsfeld – Einbaulage Boden auf Rücken Mitte
1. Fitting the riser section – Mounting position: Base section via rear section in the centre
1. Montage de la zone d'installation verticale – jeux de barres dans la base à l'arrière au centre

- 1.10 Montage des N-Sammelschienensystems
- 1.10 Fitting the N busbar system
- 1.10 Montage des jeux de barres Neutre

A107358

Werkstoff/Material/Matière
2.0065 (DIN EN 13599 – Cu-ETP)

Ausführung Version Modèle	A mm	B mm	100 % N (4 x 50 x 10)	50 % N (2 x 50 x 10)
600_50 mm_N1.1	249,5	171,5	✓	✓
600_50 mm_N1.2	239,5	151,5	✓	✗
600_50 mm_N1.3	269,5	181,5	✓	✓
600_50 mm_N1.4	229,5	141,5	✓	✗
800_50 mm_N1.1	249,5	371,5	✓	✓
800_50 mm_N1.2	239,5	351,5	✓	✗
800_50 mm_N1.3	269,5	381,5	✓	✓
800_50 mm_N1.4	229,5	341,5	✓	✗

A112994

Werkstoff/Material/Matière
2.0065 (DIN EN 13599 – Cu-ETP)

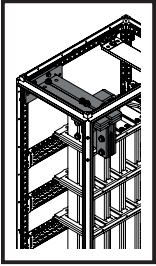

SW16/
SW17

DE EN FR



1. Montage Hochführungsfeld – Einbaulage Boden auf Rücken Mitte
1. Fitting the riser section – Mounting position: Base section via rear section in the centre
1. Montage de la zone d'installation verticale – jeux de barres dans la base à l'arrière au centre

- 1.10 Montage des N-Sammelschienensystems
- 1.10 Fitting the N busbar system
- 1.10 Montage des jeux de barres Neutre

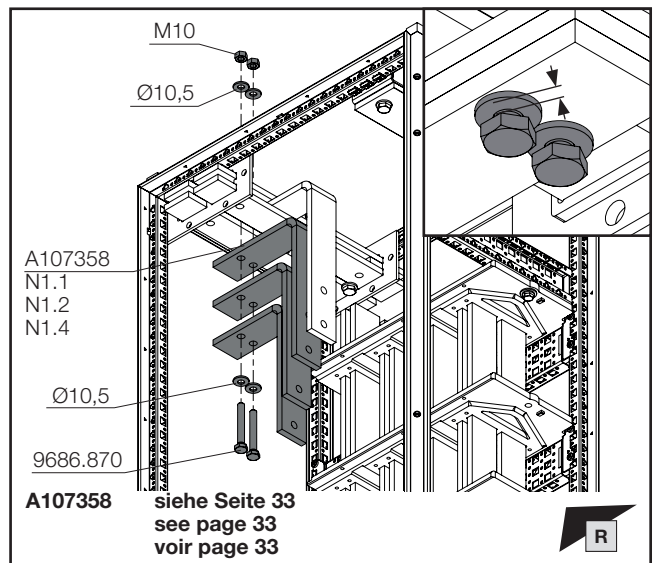
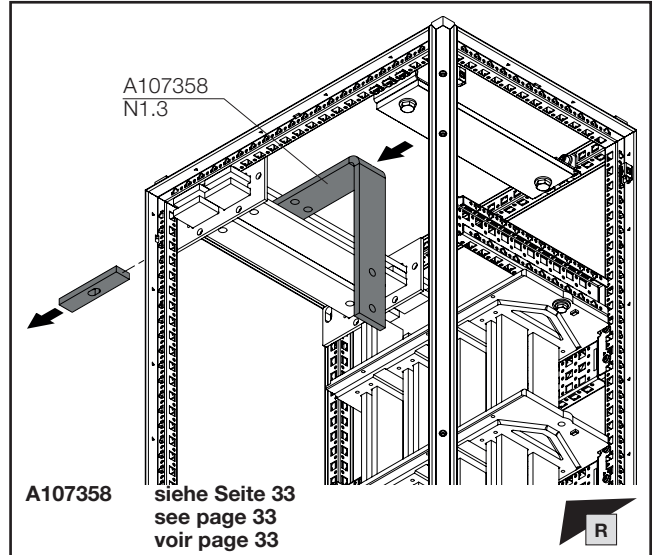
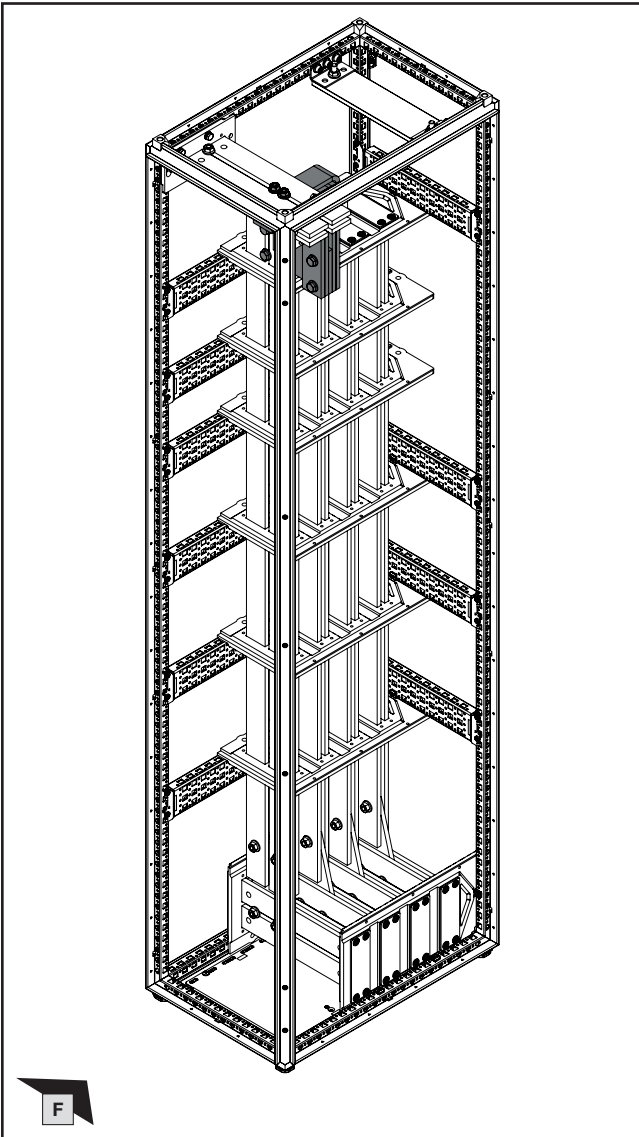

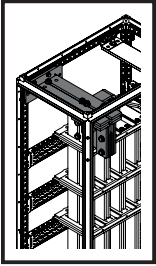

SW16/
SW17

DE EN FR



1. Montage Hochführungsfeld – Einbaulage Boden auf Rücken Mitte
1. Fitting the riser section – Mounting position: Base section via rear section in the centre
1. Montage de la zone d'installation verticale – jeux de barres dans la base à l'arrière au centre

- 1.10 Montage des N-Sammelschienensystems
- 1.10 Fitting the N busbar system
- 1.10 Montage des jeux de barres Neutre

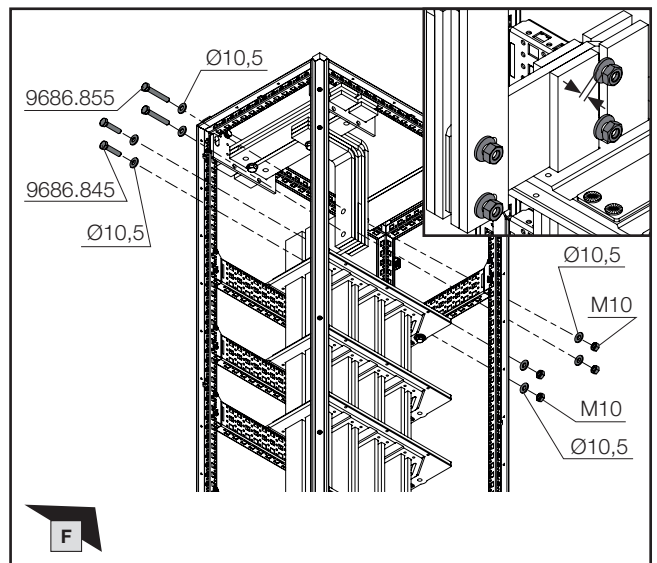
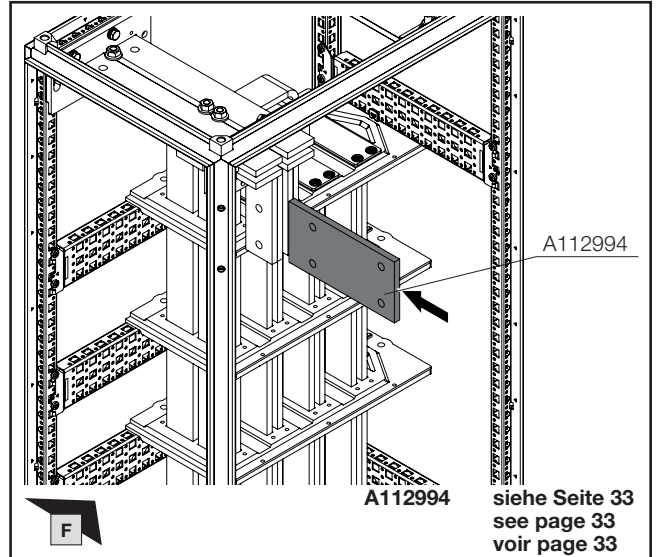
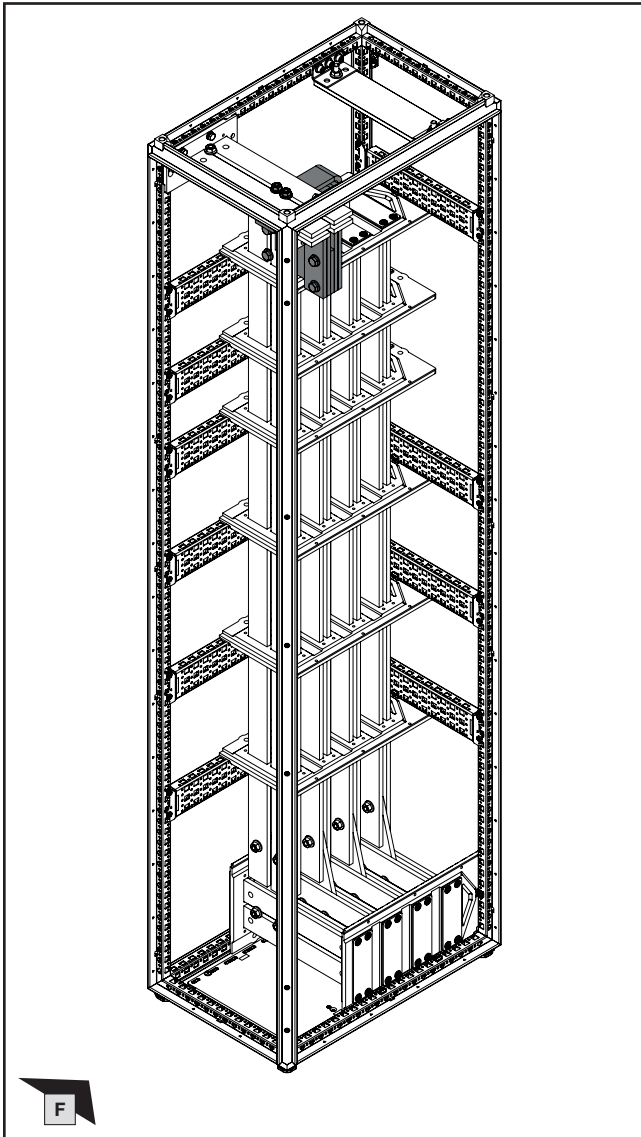

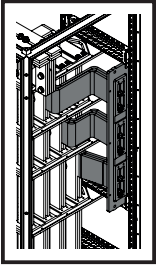

SW16/
SW17

DE EN FR



1. Montage Hochführungsfeld – Einbaulage Boden auf Rücken Mitte
1. Fitting the riser section – Mounting position: Base section via rear section in the centre
1. Montage de la zone d'installation verticale – jeux de barres dans la base à l'arrière au centre

- 1.11 Montage des vertikal Hauptschienensystems
- 1.11 Fitting the vertical main busbar system
- 1.11 Montage des jeux de barres principaux verticalement

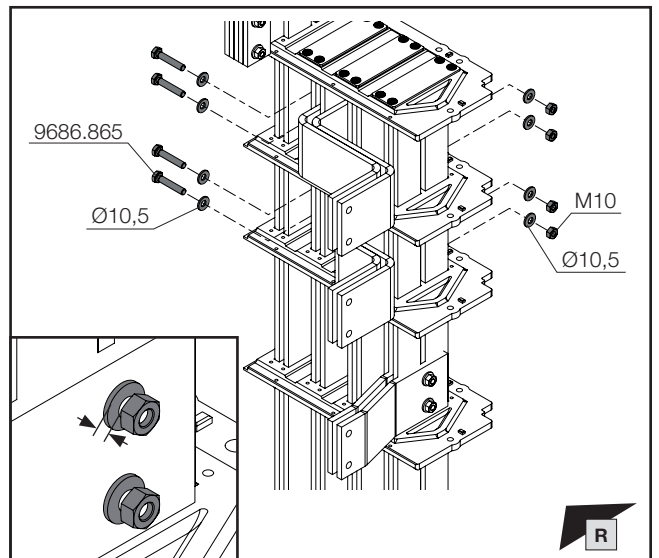
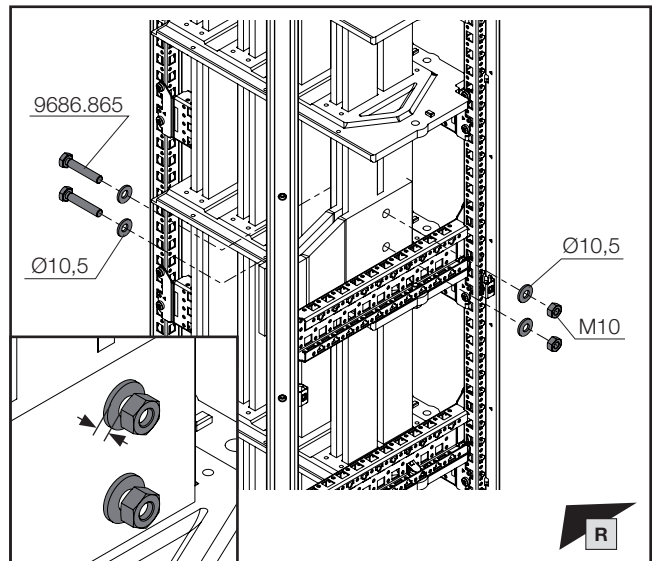
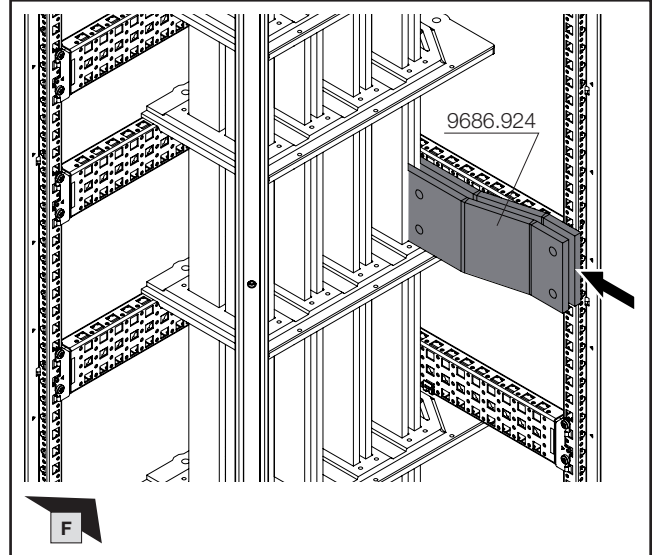
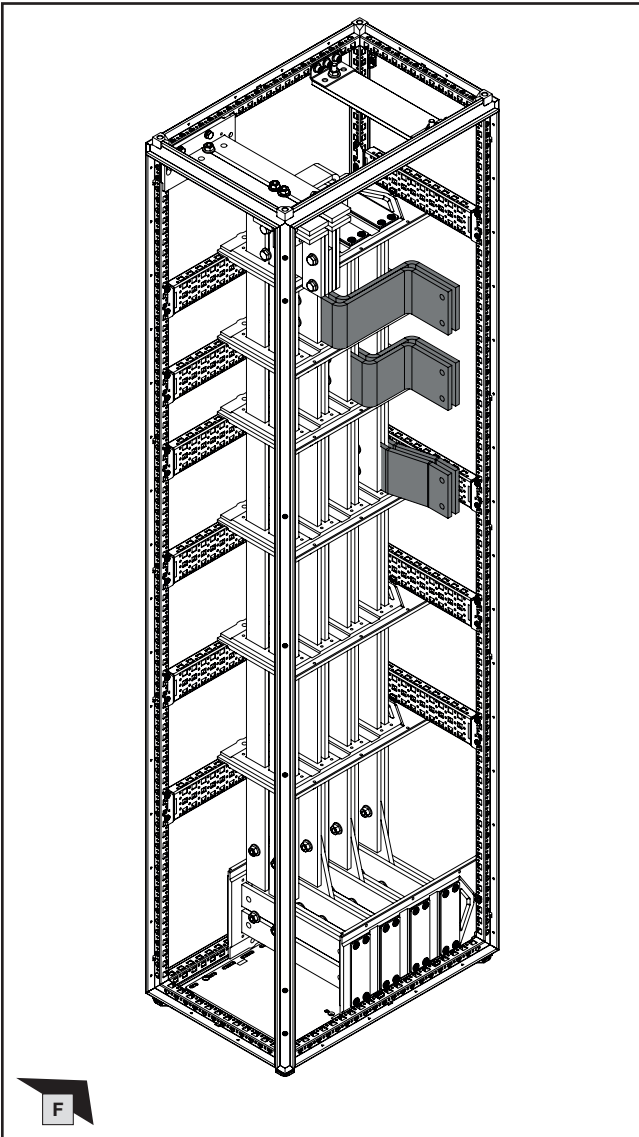

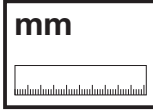
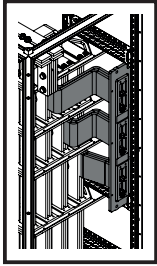

DE EN FR



1. Montage Hochführungsfeld – Einbaulage Boden auf Rücken Mitte
1. Fitting the riser section – Mounting position: Base section via rear section in the centre
1. Montage de la zone d'installation verticale – jeux de barres dans la base à l'arrière au centre

- 1.11 Montage des vertikalen Hauptschienensystems
- 1.11 Fitting the vertical main busbar system
- 1.11 Montage des jeux de barres principaux verticalement

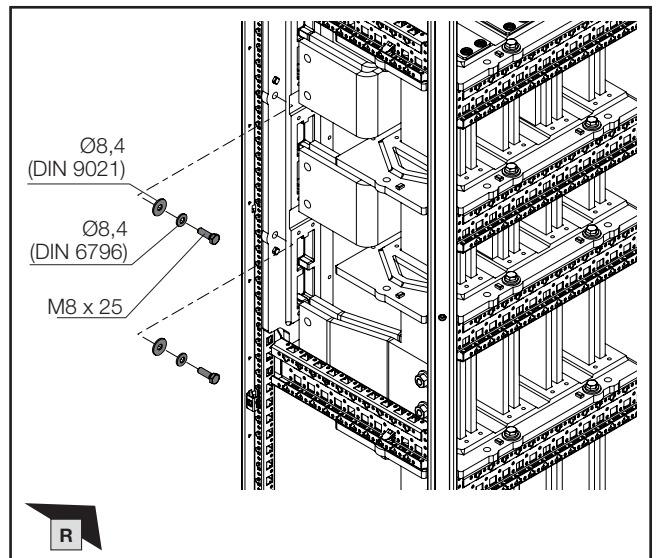
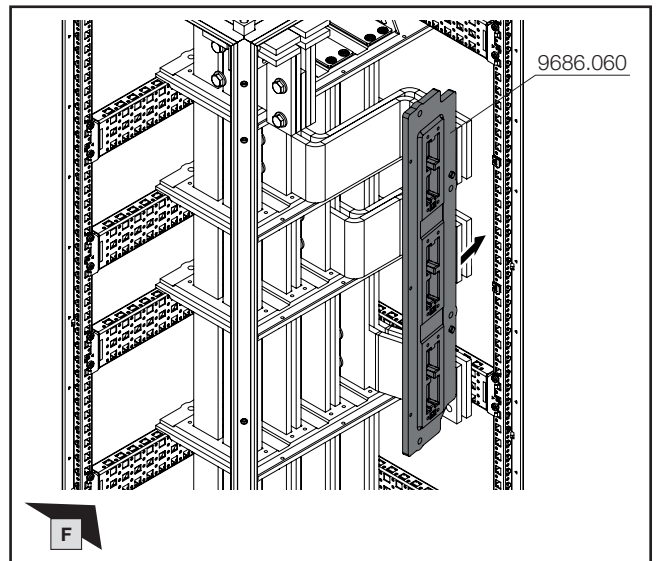
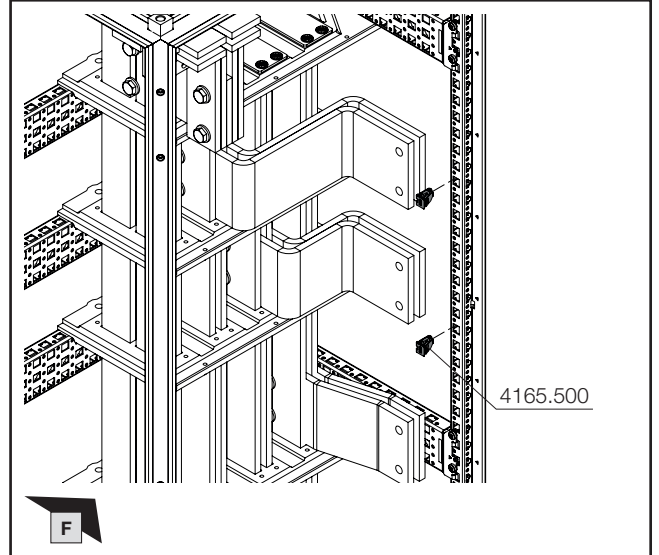
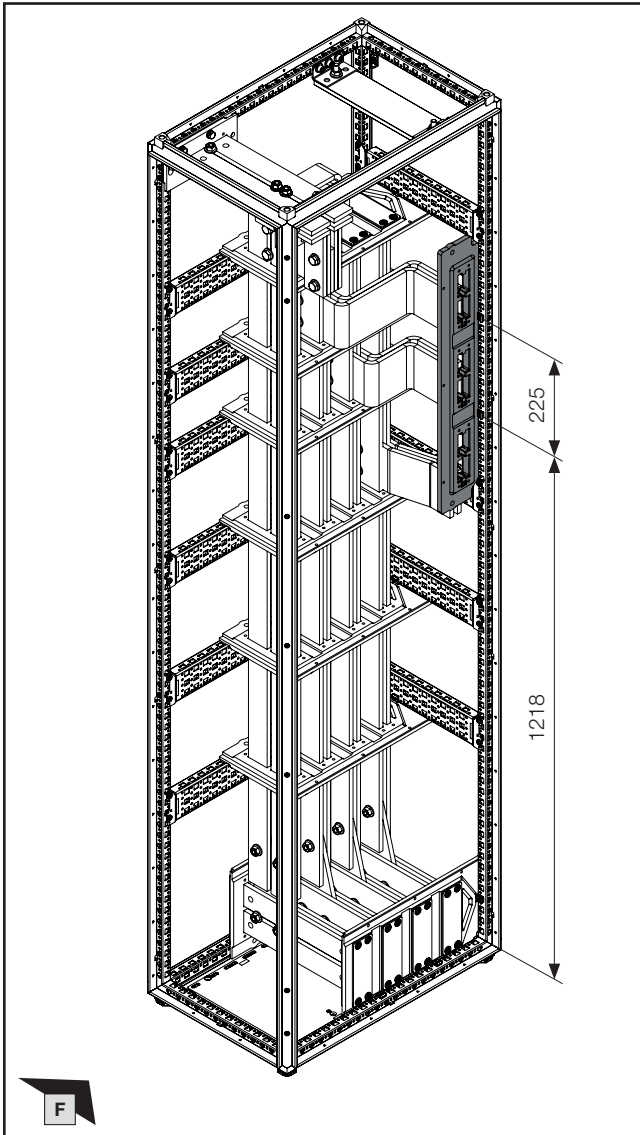

Montageanleitung VX25 Ri4Power – Schalt- und Energieverteilanlagen-System

Assembly instructions VX25 Ri4Power – Switchgear and power distribution system

Notice de montage VX25 Ri4Power – Distribution de courant

DE/EN/FR



Hinweis / Note / Remarque

Für Schutzeigenschaft Störlichtbogenklasse B Montagerihenfolge in den entsprechenden Abschnitten der o. g. Anleitung beachten.

For arcing class B protection, please follow the assembly sequence as set out in the relevant chapters of the aforementioned assembly instructions.

Pour la protection contre les arcs électriques de catégorie B, suivez la séquence de montage indiquée dans les sections correspondantes des instructions ci-dessus.

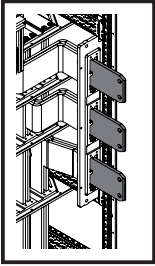

- 1. Montage Hochführungsfeld – Einbaulage Boden auf Rücken Mitte
- 1. Fitting the riser section – Mounting position: Base section via rear section in the centre
- 1. Montage de la zone d'installation verticale – jeux de barres dans la base à l'arrière au centre

- 1.12 Montage der Anreihverbinder vertikales Hauptschienen-system
- 1.12 Fitting the baying connectors for the vertical main bus-bar system
- 1.12 Montage des attaches de juxtaposition pour les jeux de barres principaux

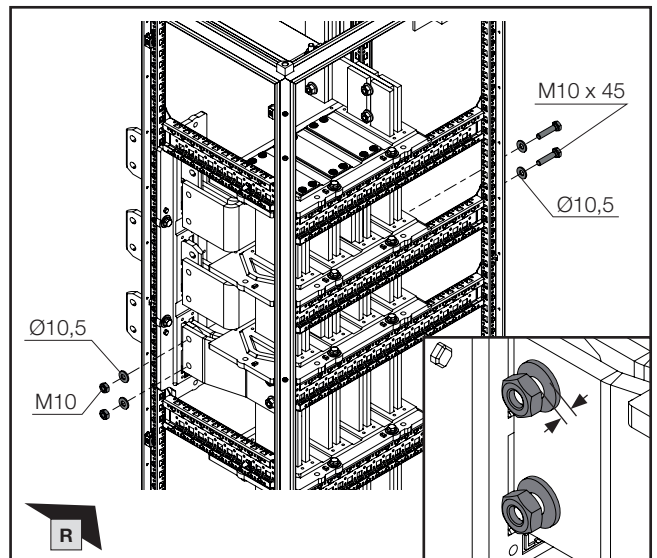
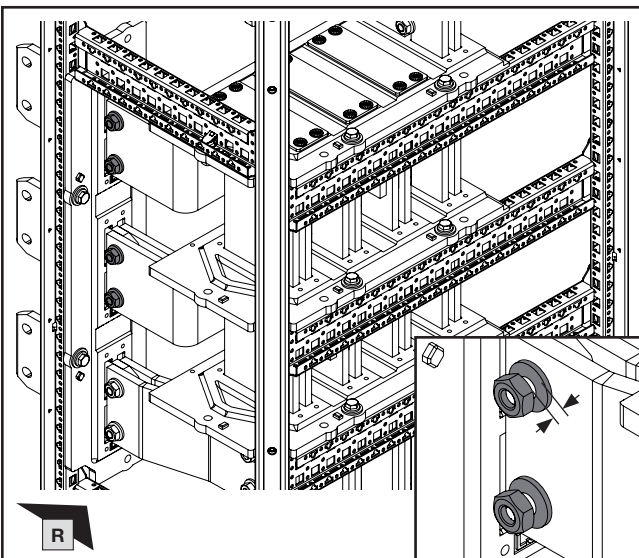
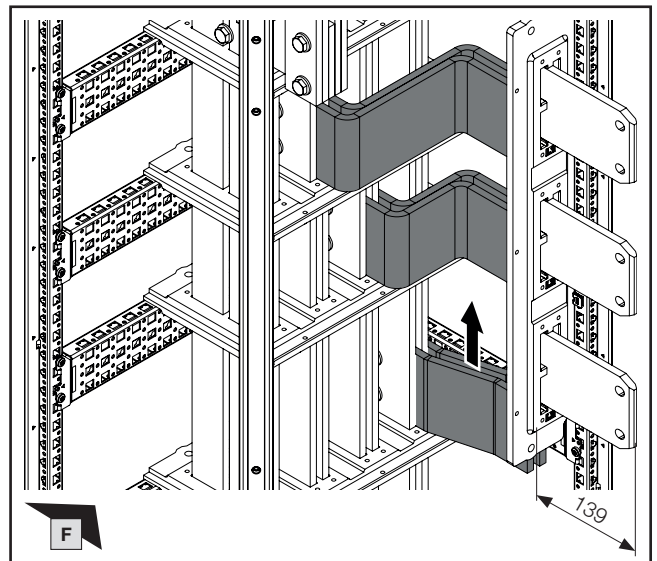
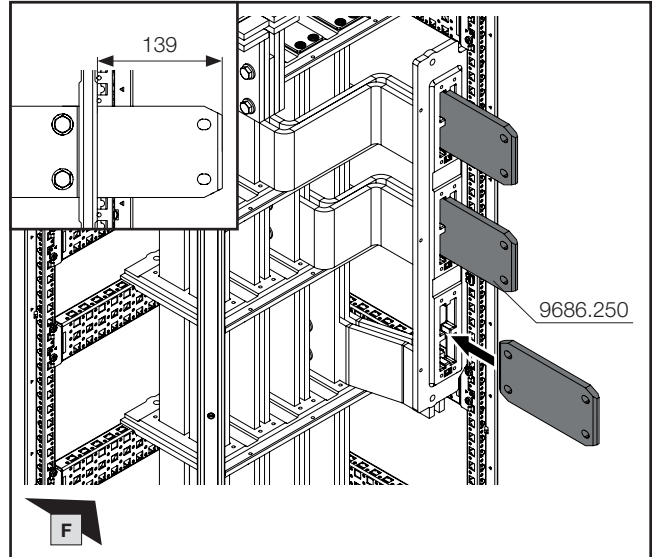
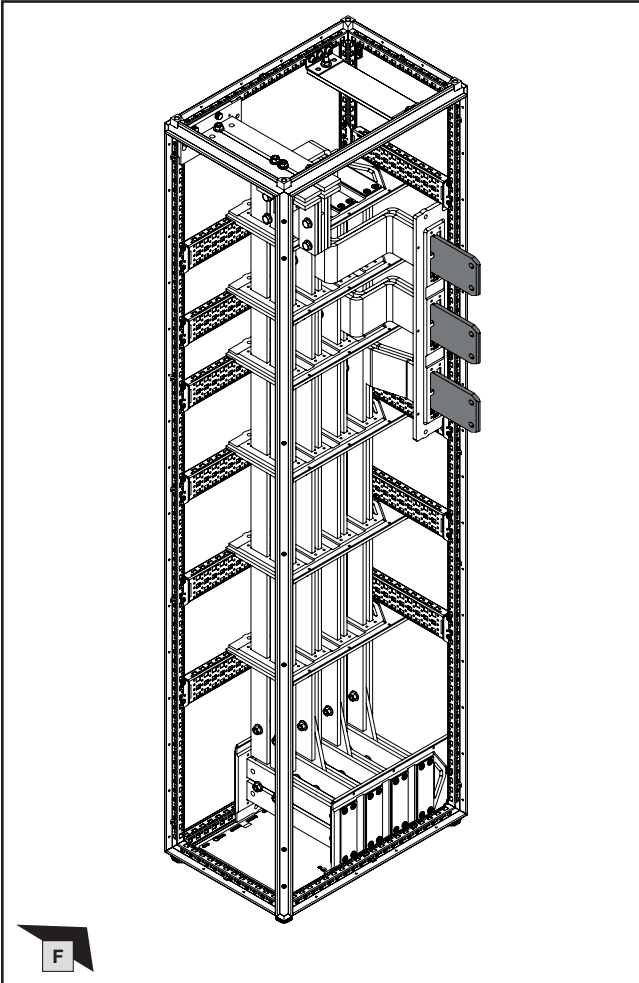

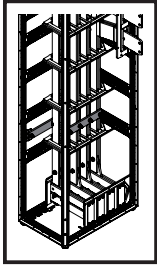

1. Montage Hochführungsfeld – Einbaulage Boden auf Rücken Mitte
 1. Fitting the riser section – Mounting position: Base section via rear section in the centre
 1. Montage de la zone d'installation verticale – jeux de barres dans la base à l'arrière au centre

- 1.13 Montage des Stabilisators
 1.13 Fitting the stabiliser
 1.13 Montage du stabilisateur

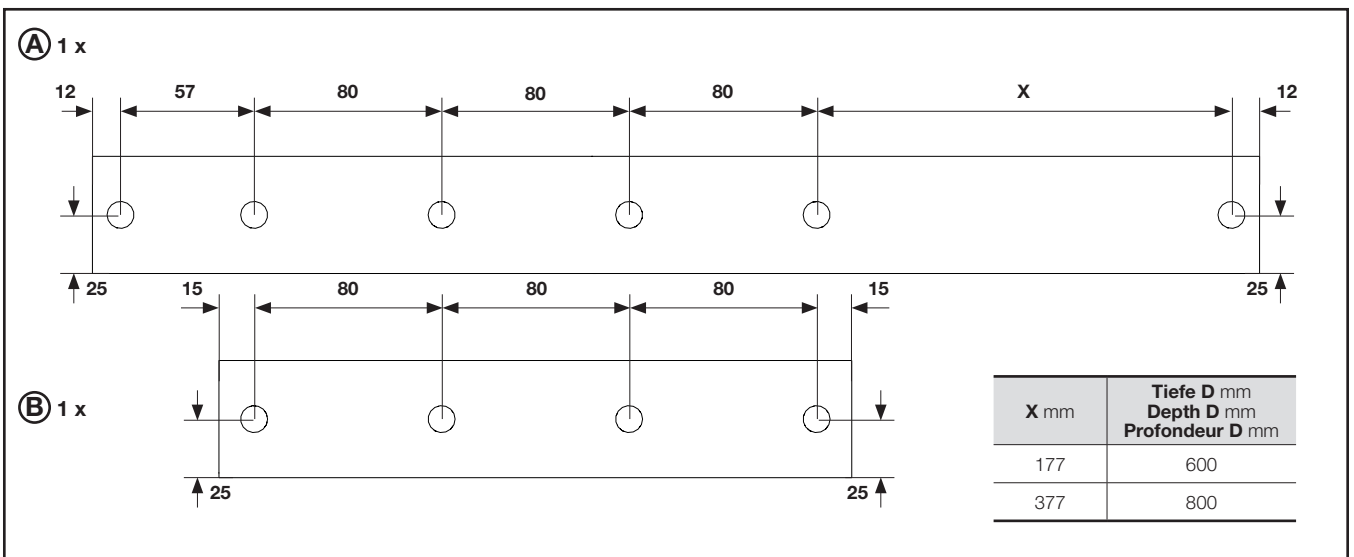
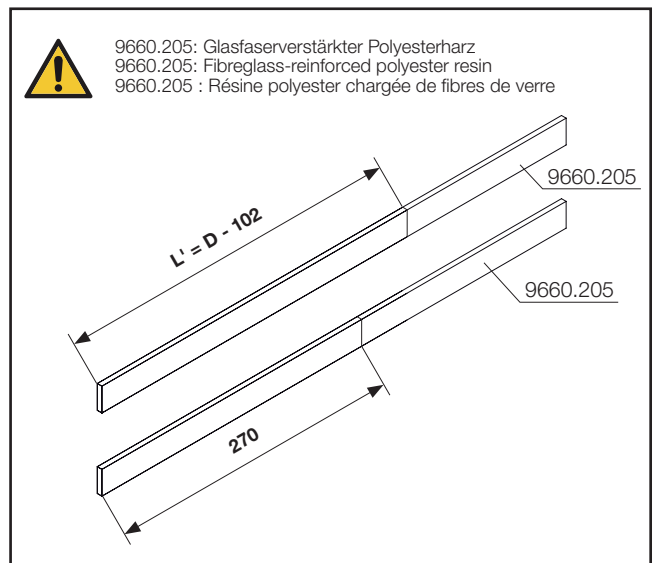
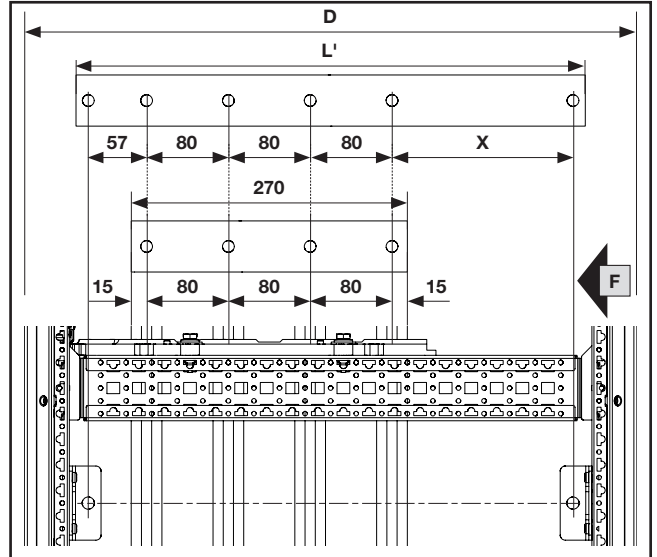
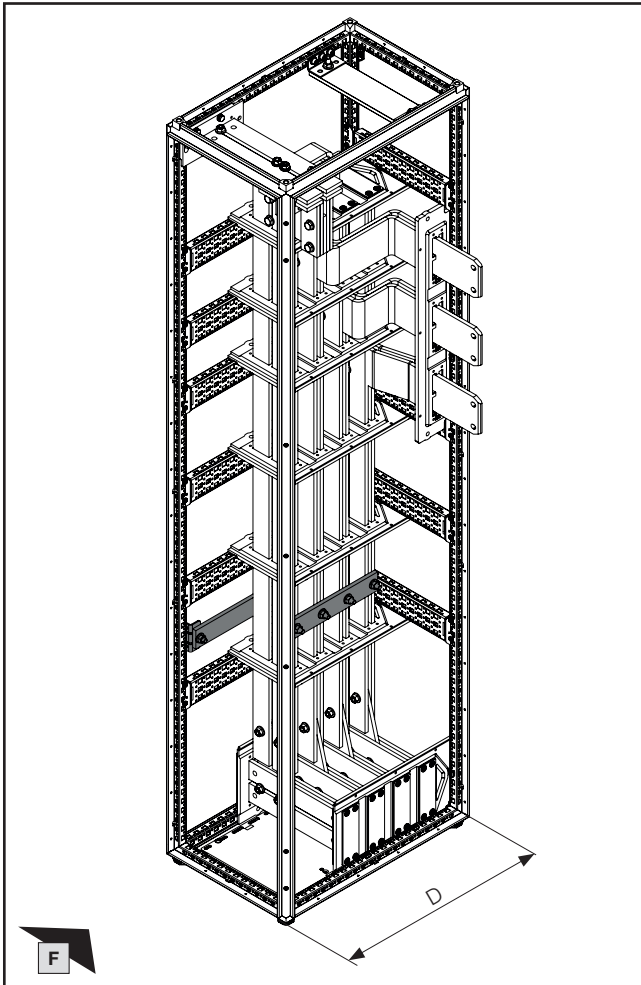

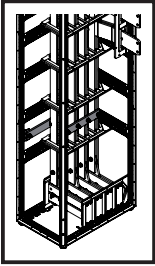

1. Montage Hochführungsfeld – Einbaulage Boden auf Rücken Mitte
1. Fitting the riser section – Mounting position: Base section via rear section in the centre
1. Montage de la zone d'installation verticale – jeux de barres dans la base à l'arrière au centre

- 1.13 Montage des Stabilisateurs
- 1.13 Fitting the stabiliser
- 1.13 Montage du stabilisateur

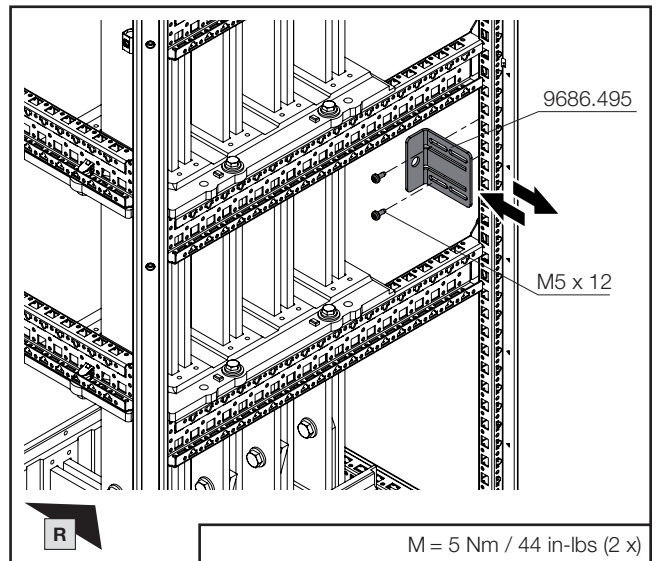
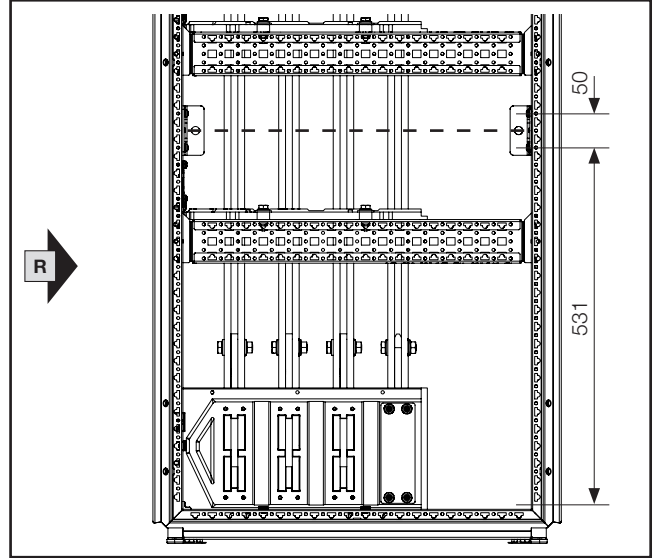
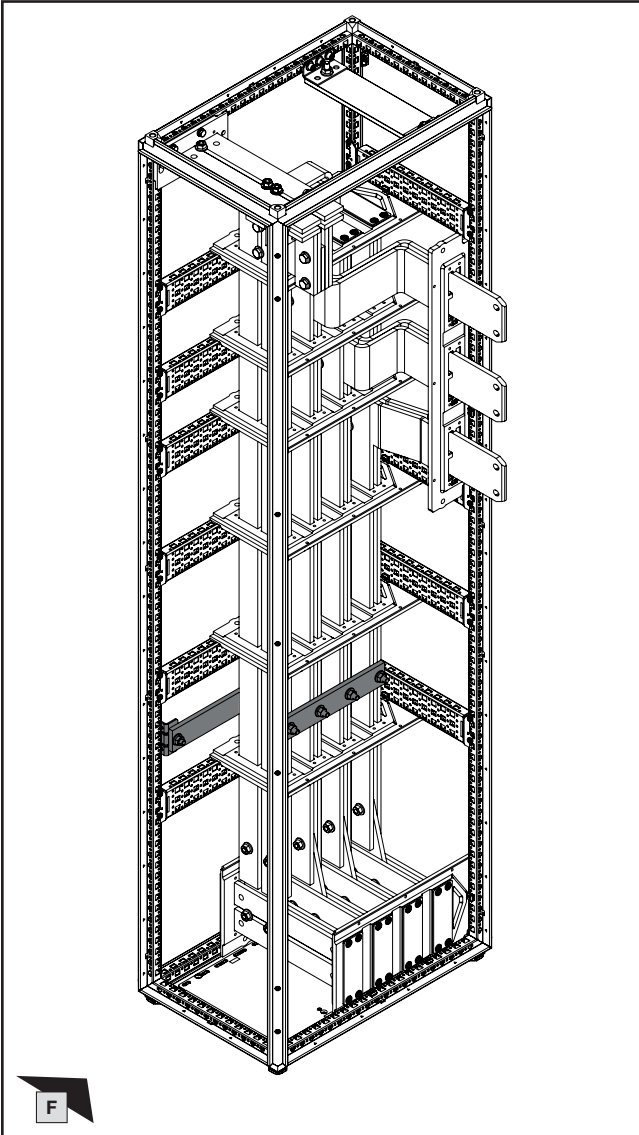

M = 5 Nm / 44 in-lbs (2 x)

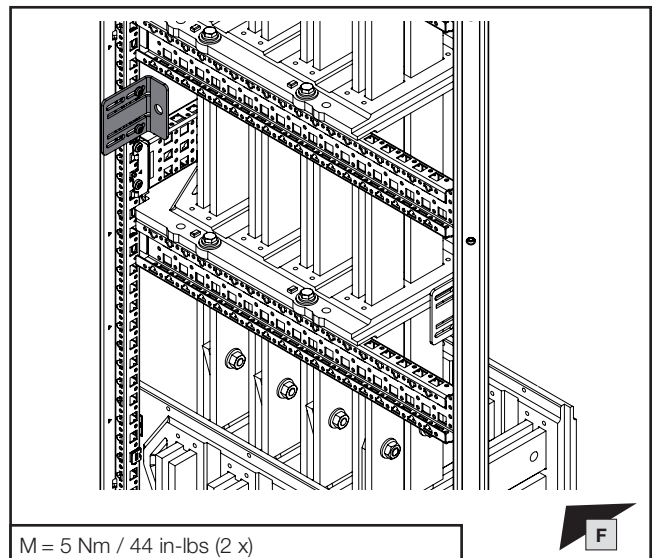
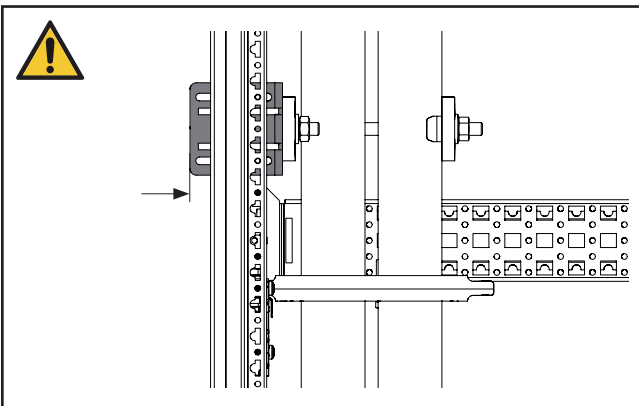

M = 5 Nm / 44 in-lbs (2 x)

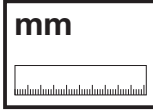
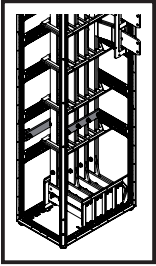

DE EN FR



1. Montage Hochführungsfeld – Einbaulage Boden auf Rücken Mitte
1. Fitting the riser section – Mounting position: Base section via rear section in the centre
1. Montage de la zone d'installation verticale – jeux de barres dans la base à l'arrière au centre

- 1.13 Montage des Stabilisators
- 1.13 Fitting the stabiliser
- 1.13 Montage du stabilisateur

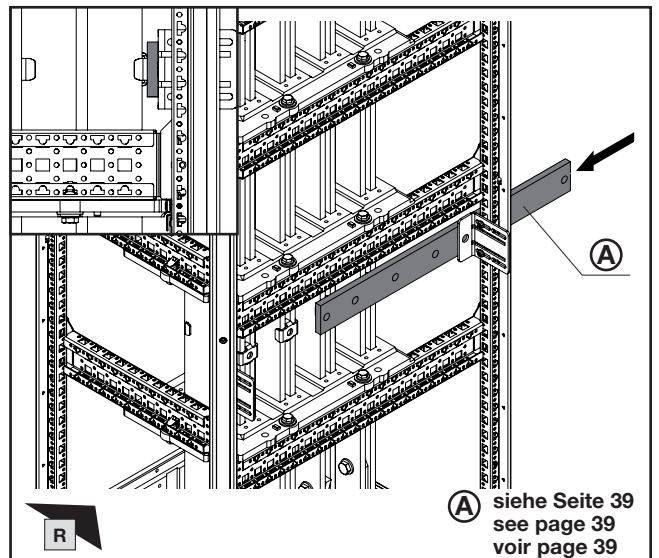
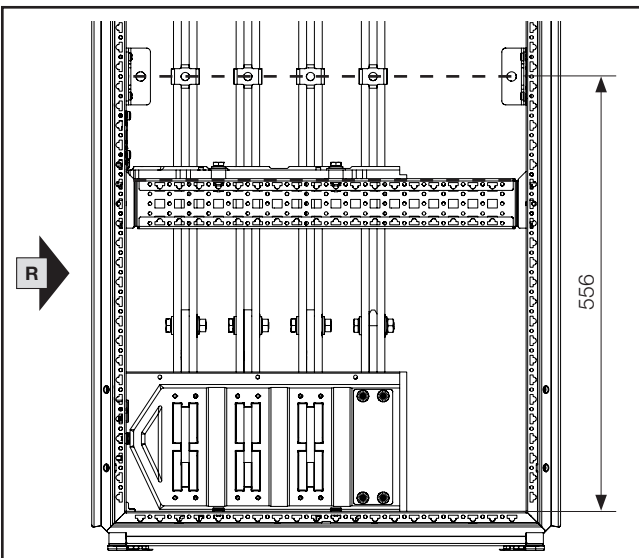
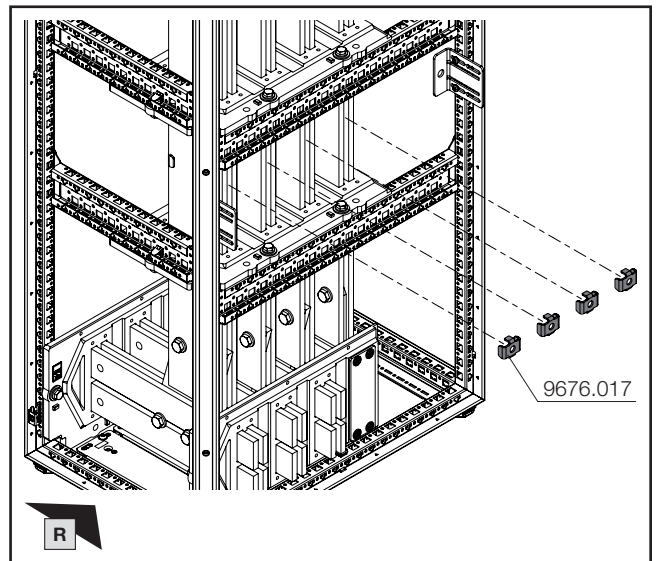
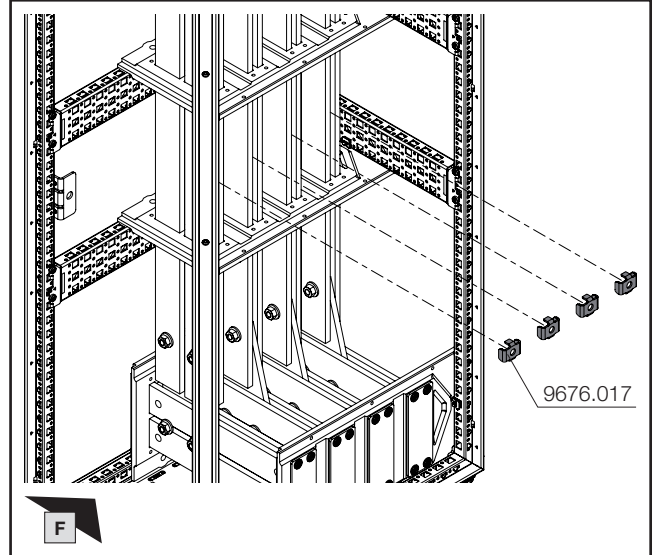
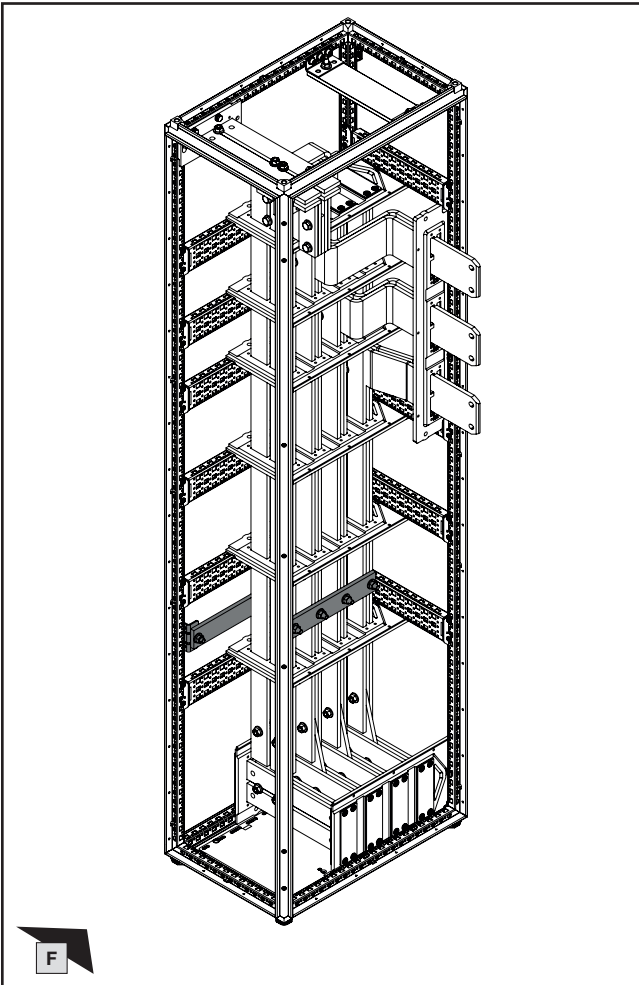

A siehe Seite 39
see page 39
voir page 39

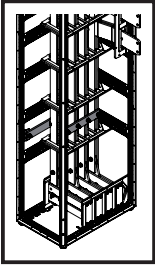

SW16/
SW17

DE EN FR



1. Montage Hochführungsfeld – Einbaulage Boden auf Rücken Mitte
1. Fitting the riser section – Mounting position: Base section via rear section in the centre
1. Montage de la zone d'installation verticale – jeux de barres dans la base à l'arrière au centre

- 1.13 Montage des Stabilisateurs
- 1.13 Fitting the stabiliser
- 1.13 Montage du stabilisateur

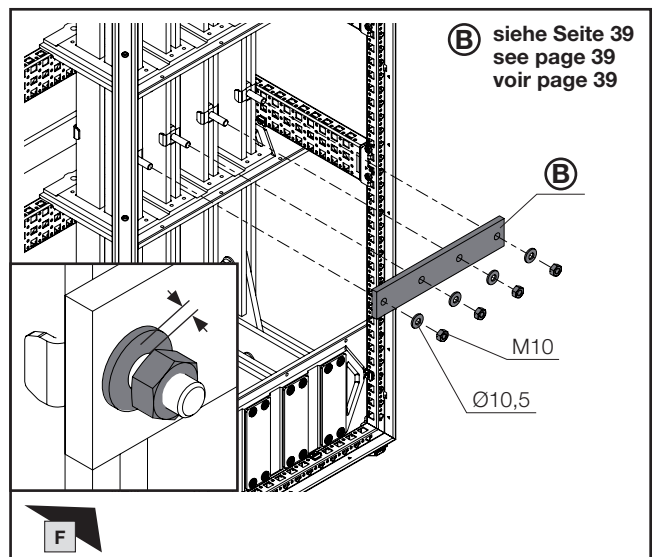
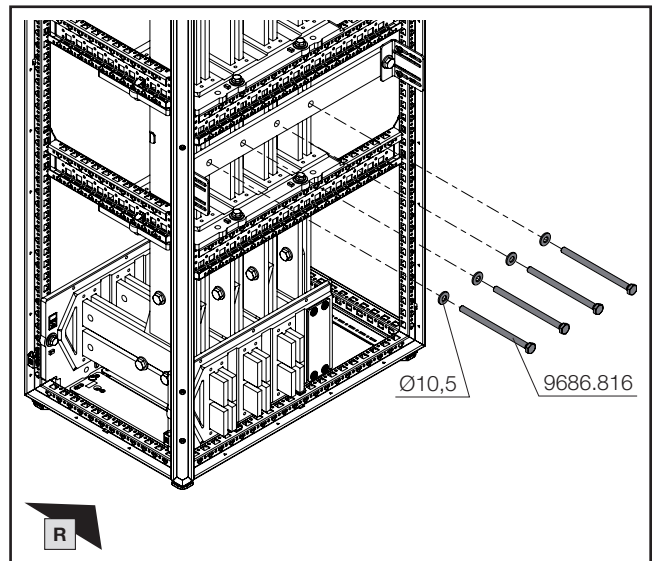
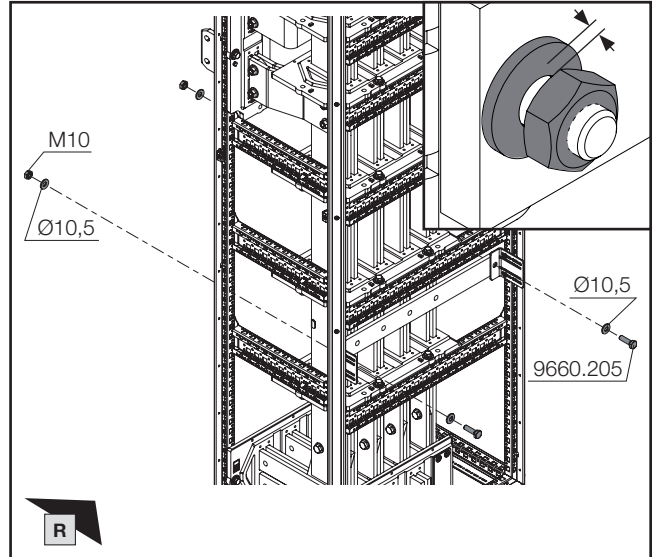
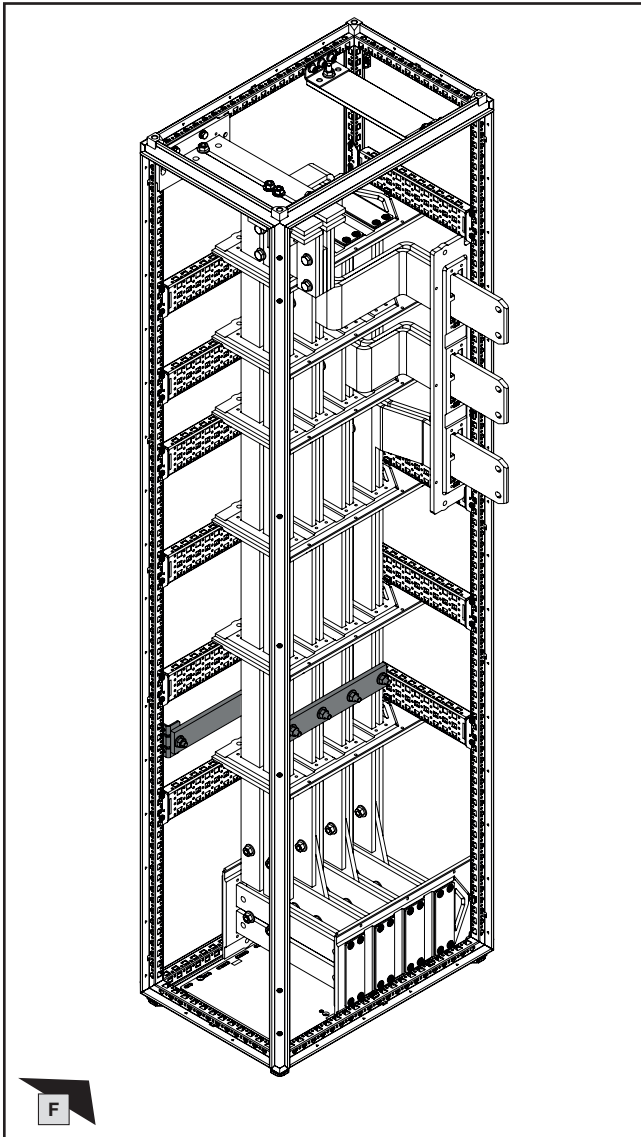

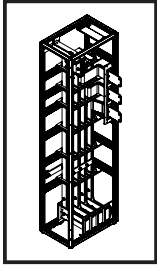

SW16/
SW17

DE EN FR



1. Montage Hochführungsfeld – Einbaulage Boden auf Rücken Mitte
1. Fitting the riser section – Mounting position: Base section via rear section in the centre
1. Montage de la zone d'installation verticale – jeux de barres dans la base à l'arrière au centre

- 1.14 Anziehen der Schrauben
- 1.14 Tightening the screws
- 1.14 Serrage des vis

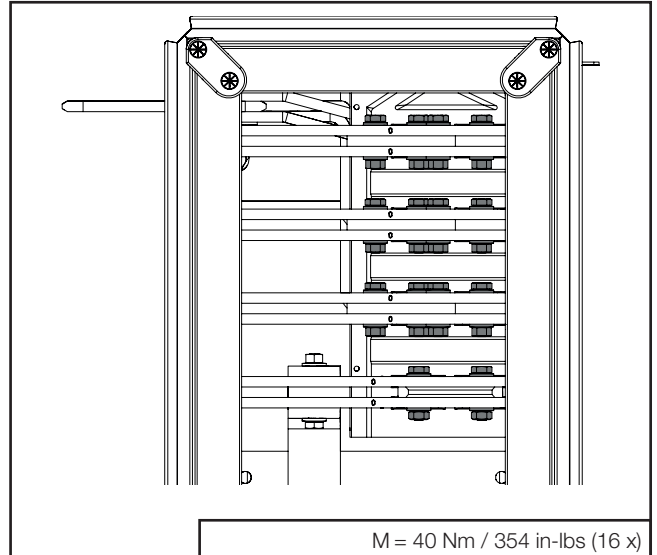
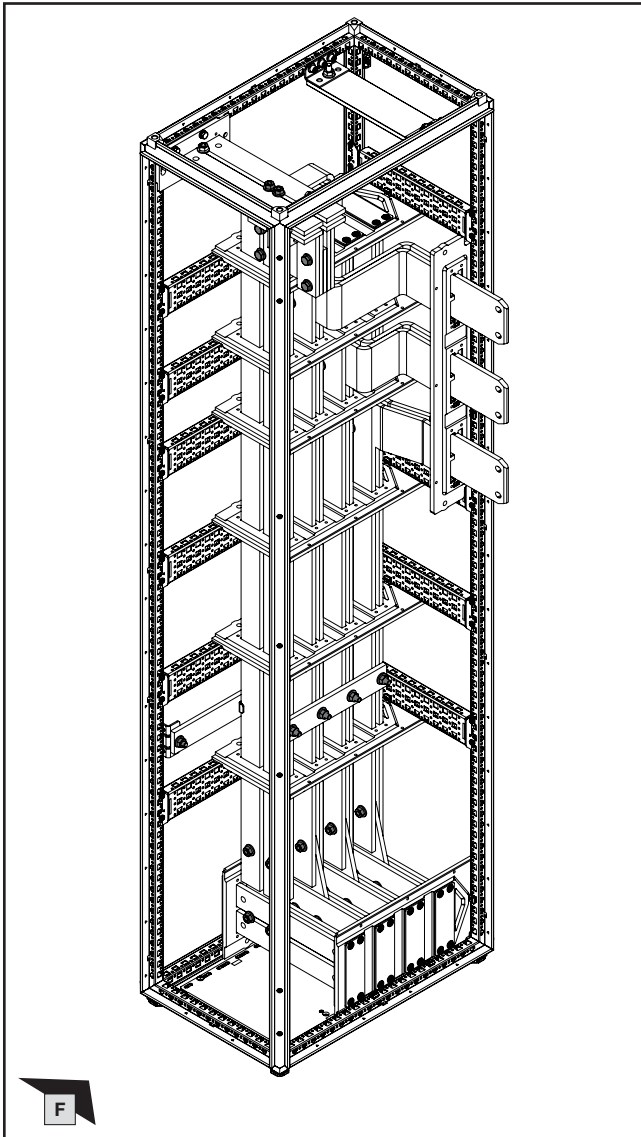

M = 40 Nm / 354 in-lbs (16 x)

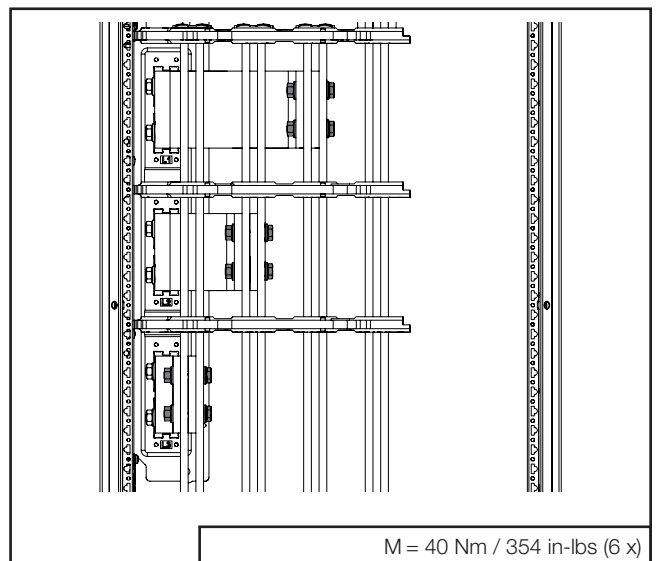

M = 40 Nm / 354 in-lbs (6 x)

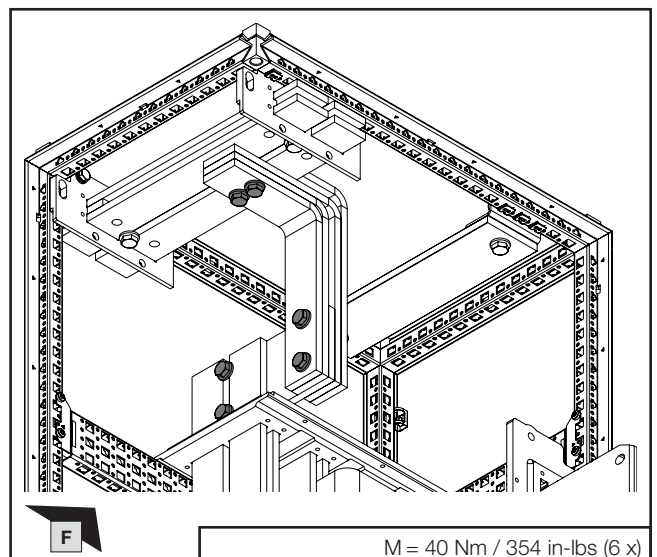

M = 40 Nm / 354 in-lbs (6 x)

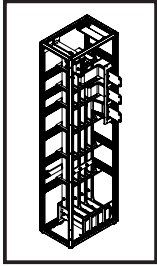

SW16/
SW17

DE EN FR



1. Montage Hochführungsfeld – Einbaulage Boden auf Rücken Mitte
1. Fitting the riser section – Mounting position: Base section via rear section in the centre
1. Montage de la zone d'installation verticale – jeux de barres dans la base à l'arrière au centre

- 1.14 Anziehen der Schrauben
- 1.14 Tightening the screws
- 1.14 Serrage des vis

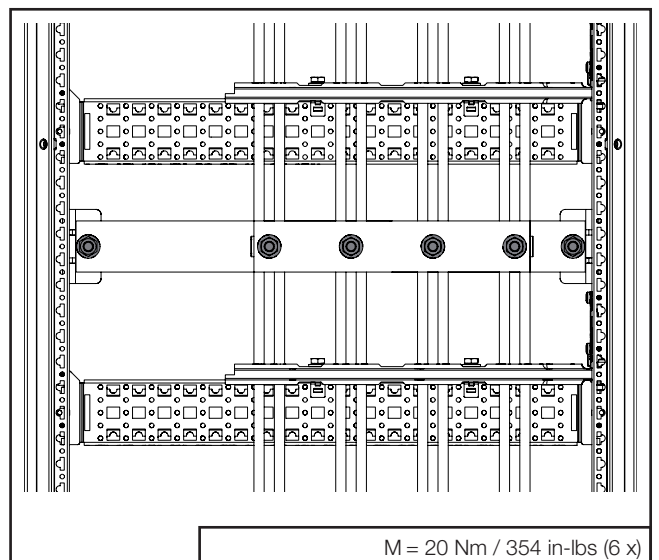
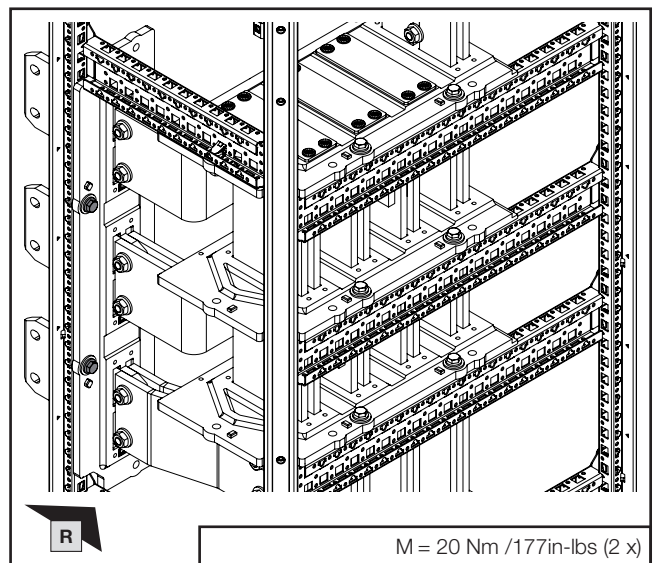
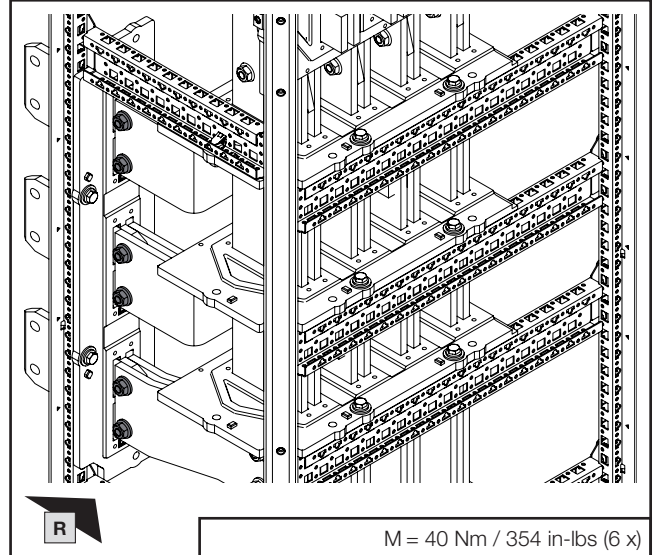
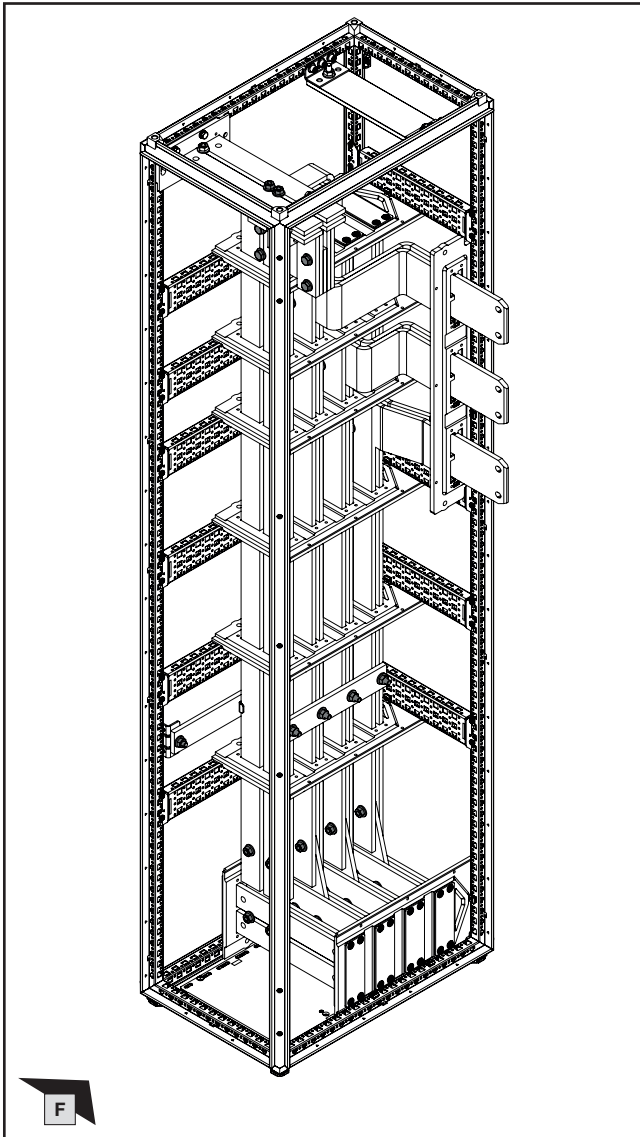

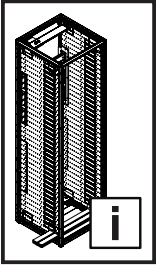

- 2. Montage Beispielvariante Rückbereich Mitte – Sammelschienensystem N und PE
- 2. Fitting for a variant example – Rear area in the centre, busbar system N and PE
- 2. Exemple du montage au milieu à l'arrière – jeux de barres Neutre et Terre

- 2.1 Beispielvariante Rückbereich Mitte – leeres Feld
- 2.1 Variant example – Rear area, centre – Empty section
- 2.1 Exemple du montage au milieu à l'arrière – zone vide

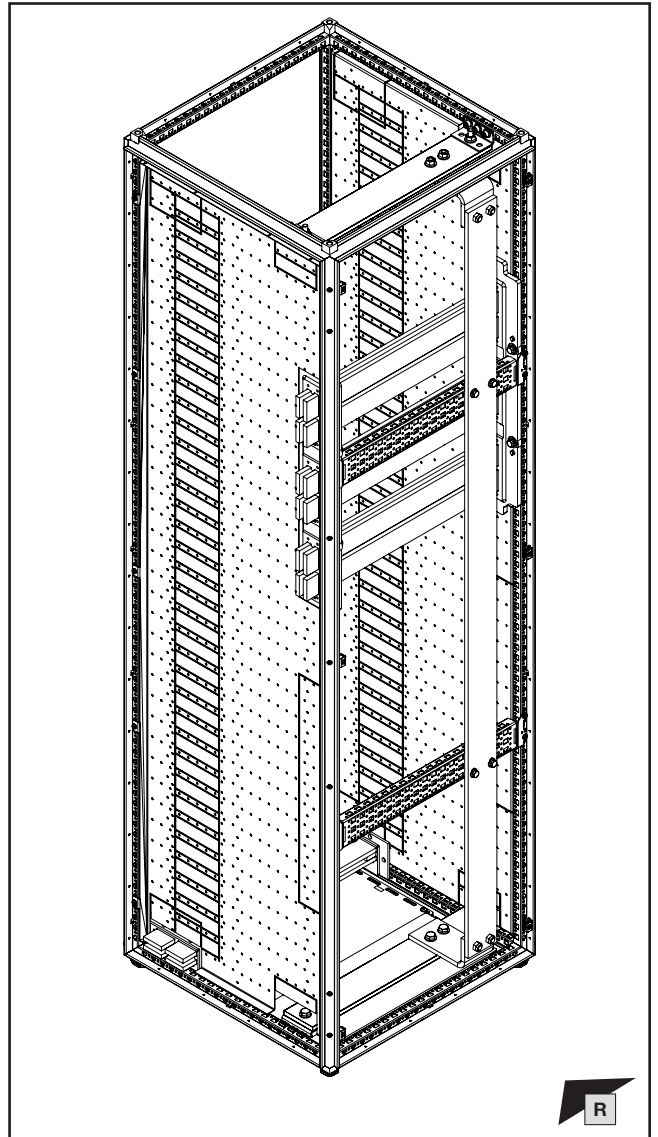
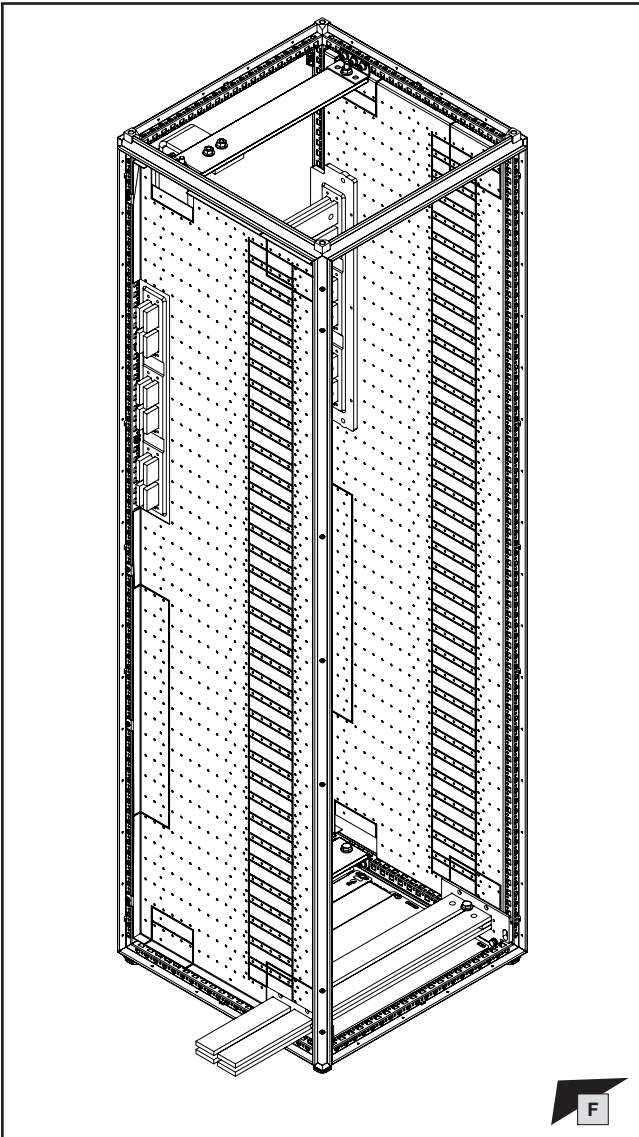

Hinweis / Note / Remarque

Die Anbindung an das Sammelschienensystem Rückbereich Mitte wird in den folgenden Abschnitten beispielhaft an einem „Leerfeld“ gezeigt. Anwendungsspezifisch dürfen alle Feldtypen angereicht werden.

The following chapters describe connection to the busbar system in the central rear area, for an "empty section". All section types can be bayed, as required for the particular application.

Dans les paragraphes suivants, le raccordement au jeu de barres à l'arrière au milieu est montré avec l'exemple d'un « emplacement non utilisé ». Tous les types de cellules peuvent, selon l'application, être juxtaposés.

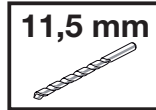
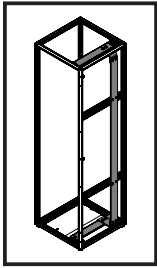

2. Montage Beispielvariante Rückbereich Mitte – Sammelschienensystem N und PE
2. Fitting for a variant example – Rear area in the centre, busbar system N and PE
2. Exemple du montage au milieu à l'arrière – jeux de barres Neutre et Terre

- 2.2 Montage PE-/PEN-Sammelschienensystem
- 2.2 Fitting the PE/PEN busbar system
- 2.2 Montage des jeux de barres Terre / Terre-Neutre

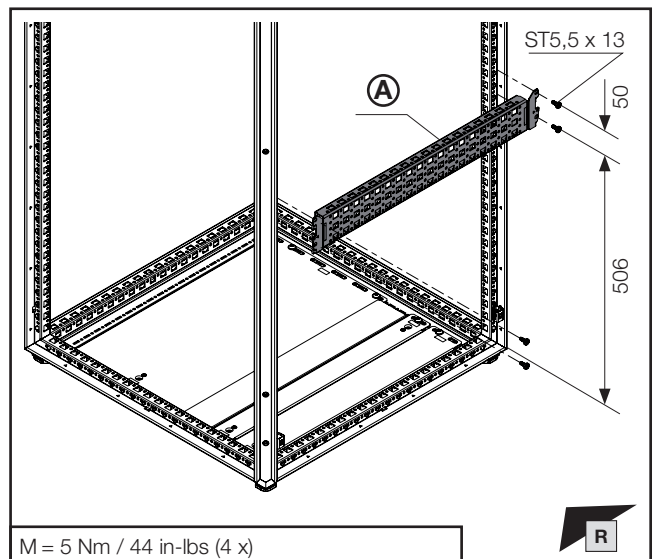
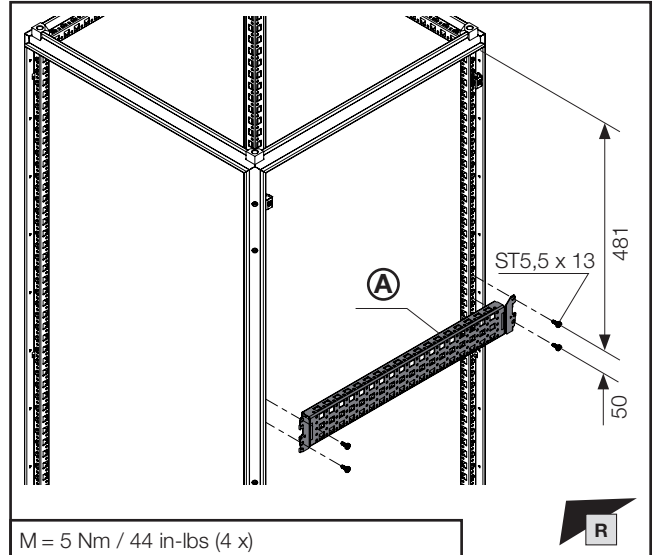
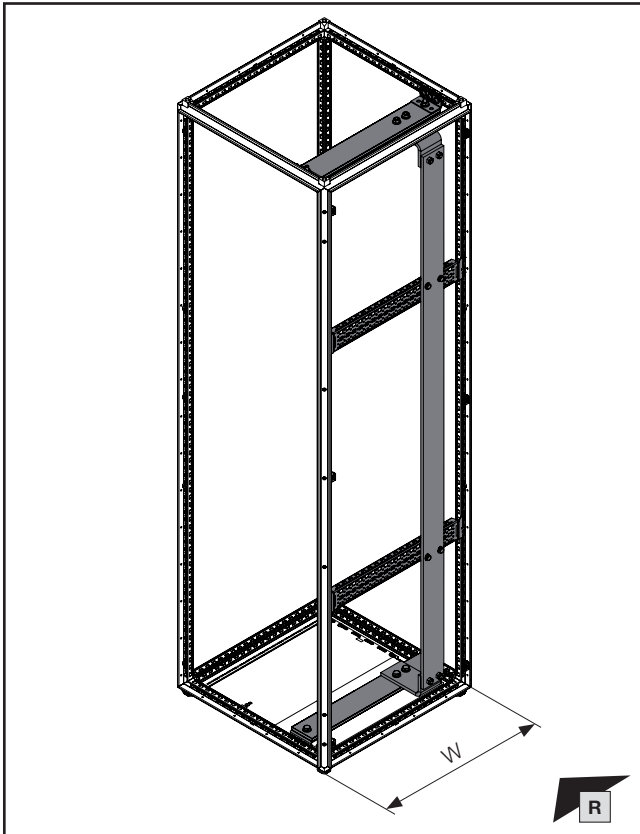

Breite W mm Width W mm Largeur W mm	(A) Best.-Nr. Model No. Référence
400	8617.110
600	8617.130
800	8617.140
1000	8617.150
1200	8617.160

Montageanleitung VX25 Ri4Power – Schalt- und Energieverteilanlagen-System

Assembly instructions VX25 Ri4Power – Switchgear and power distribution system

Notice de montage VX25 Ri4Power – Distribution de courant

DE/EN/FR

Schranksystem VX25 – Technische Dokumentation – Schutzleiteranschluss, Strombelastbarkeit

VX25 Enclosure System – Technical documentation – PE conductor connection, current carrying capacity

Armoires électriques VX25 – Manuel technique – Raccordement de mise à la terre et intensités maximales admissibles

DE EN FR

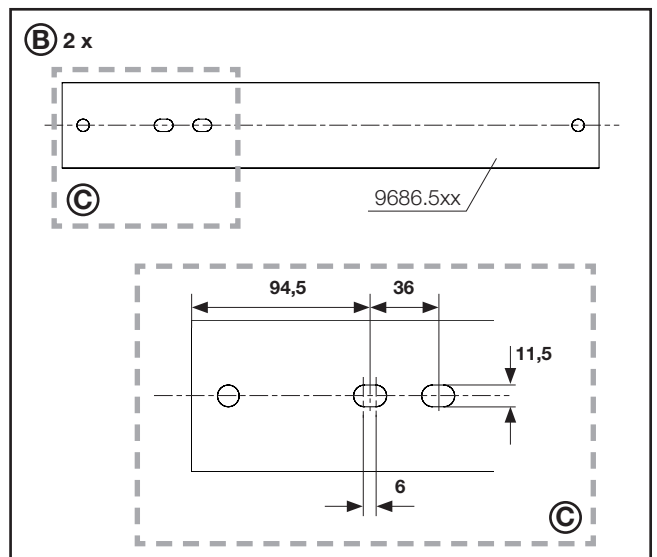

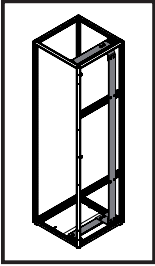

TX30

SW16/
SW17

DE EN FR



- 2. Montage Beispielvariante Rückbereich Mitte – Sammelschienensystem N und PE
- 2. Fitting for a variant example – Rear area in the centre, busbar system N and PE
- 2. Exemple du montage au milieu à l'arrière – jeux de barres Neutre et Terre

- 2.2 Montage PE-/PEN-Sammelschienensystem
- 2.2 Fitting the PE/PEN busbar system
- 2.2 Montage des jeux de barres Terre / Terre-Neutre

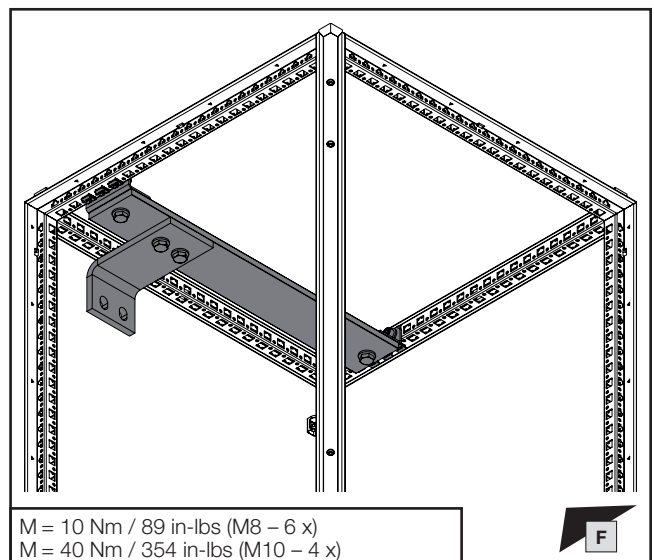
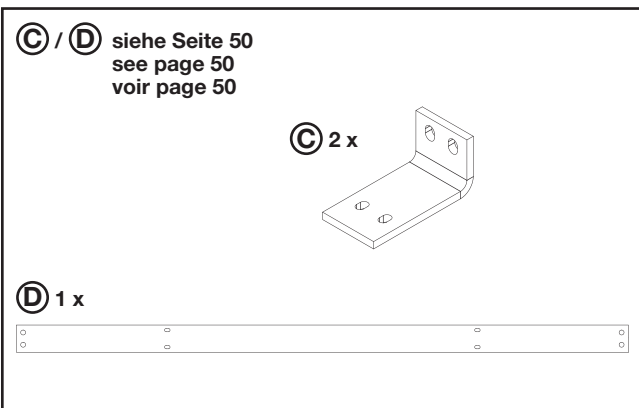
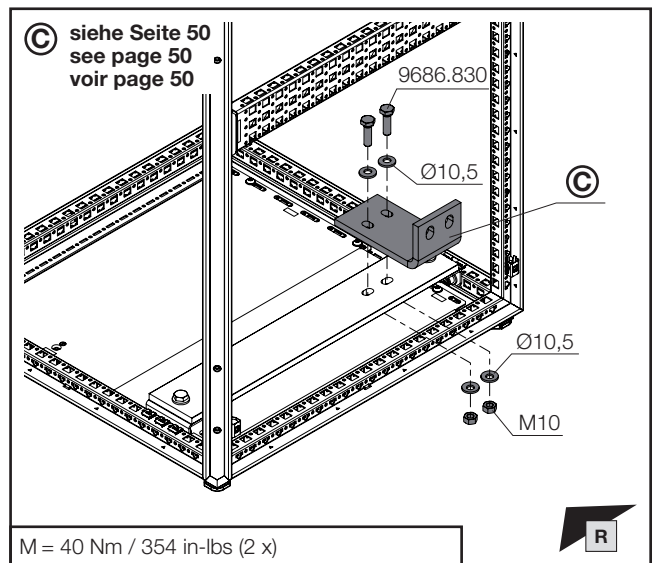
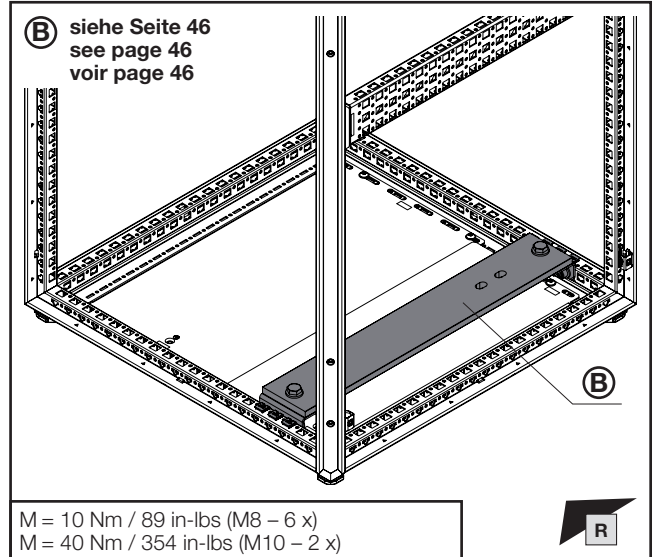
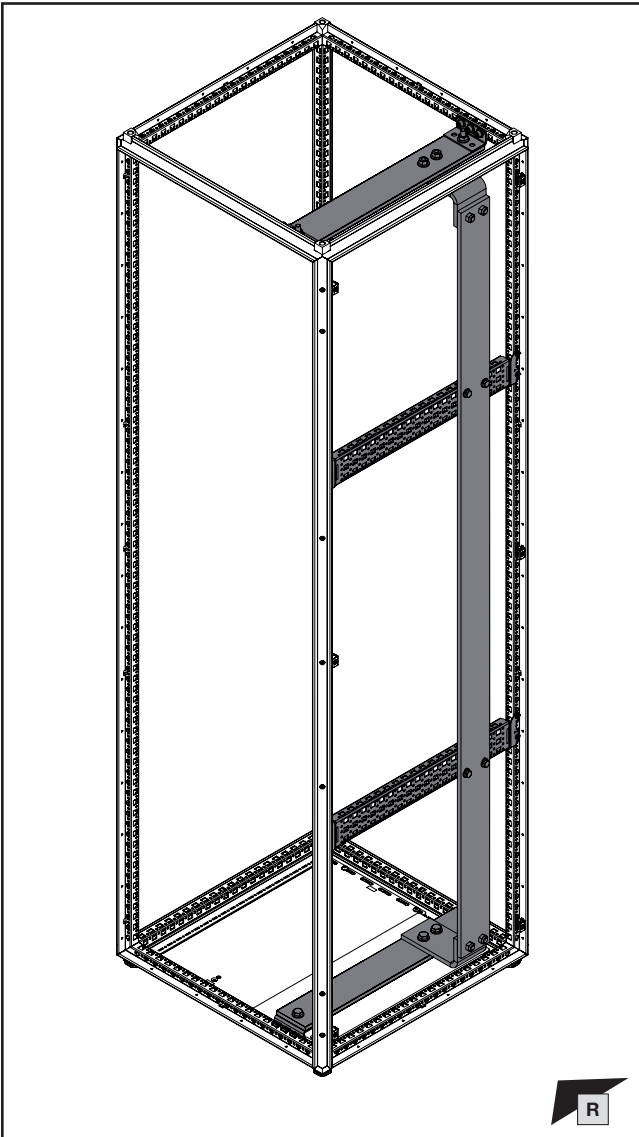

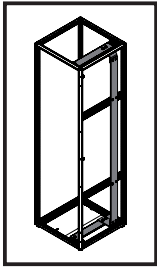

DE EN FR



2. Montage Beispielvariante Rückbereich Mitte – Sammelschienensystem N und PE
2. Fitting for a variant example – Rear area in the centre, busbar system N and PE
2. Exemple du montage au milieu à l'arrière – jeux de barres Neutre et Terre

- 2.2 Montage PE-/PEN-Sammelschienensystem
- 2.2 Fitting the PE/PEN busbar system
- 2.2 Montage des jeux de barres Terre / Terre-Neutre

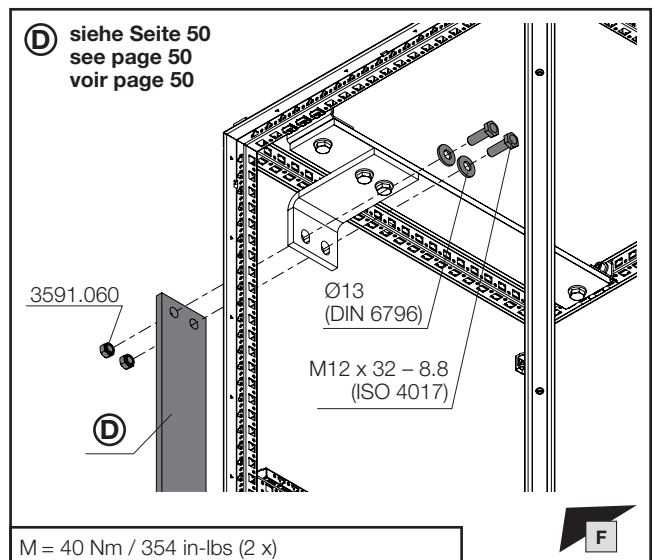
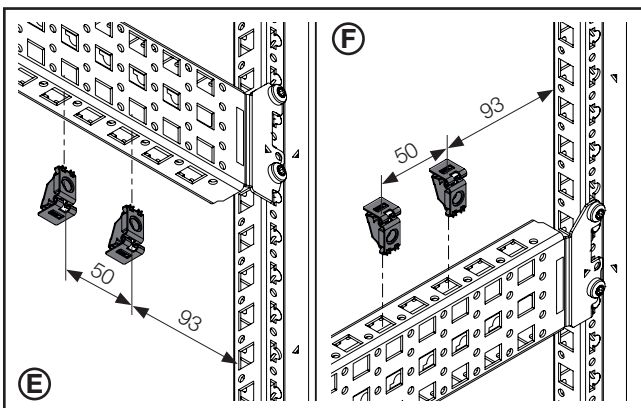
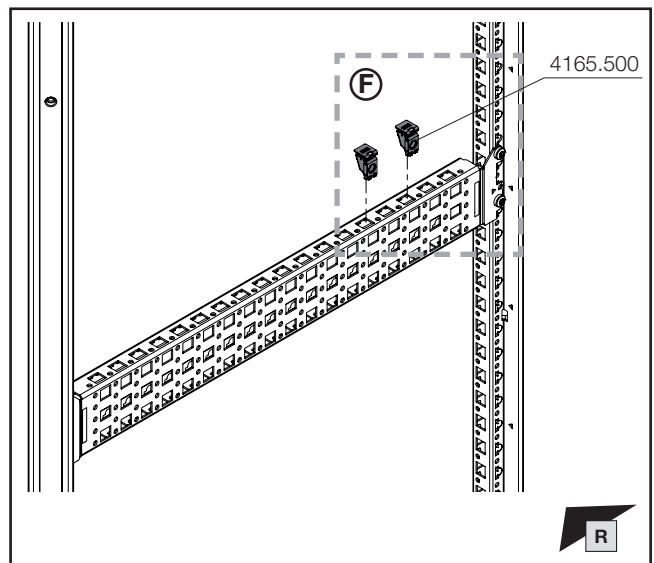
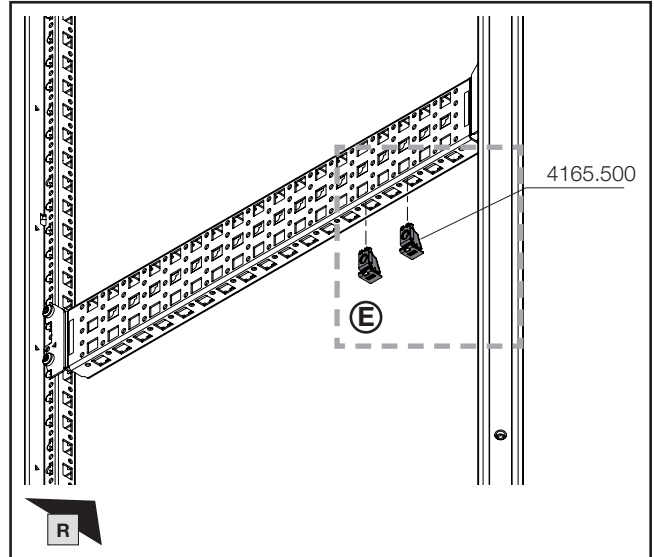
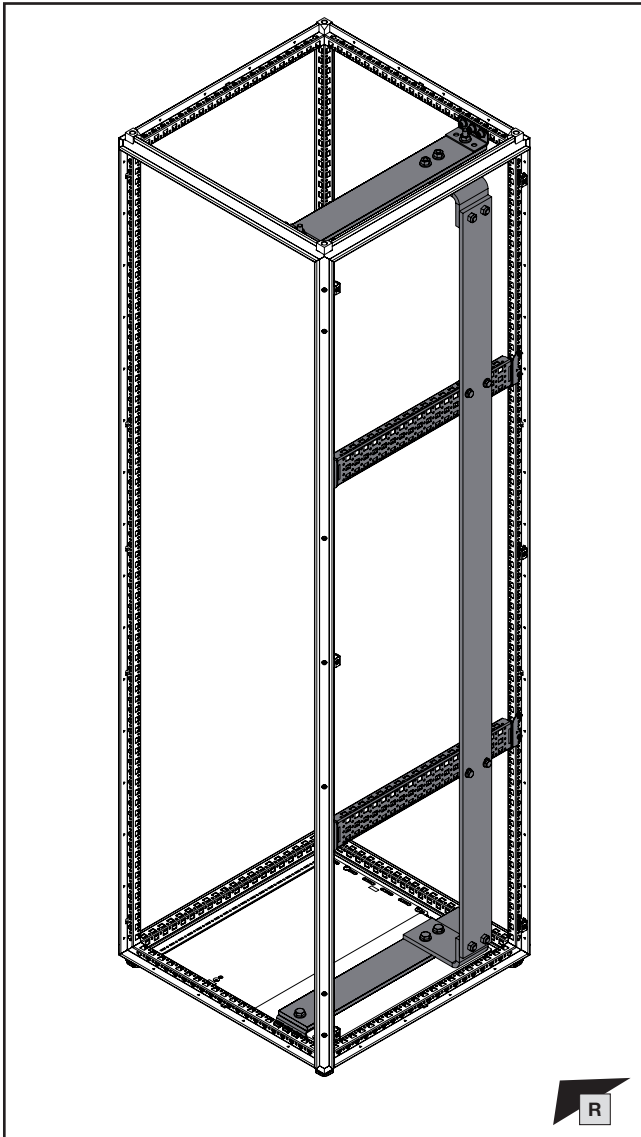

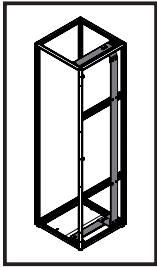

SW13



SW18/
SW19



DE EN FR



2. Montage Beispielvariante Rückbereich Mitte – Sammelschienensystem N und PE
2. Fitting for a variant example – Rear area in the centre, busbar system N and PE
2. Exemple du montage au milieu à l'arrière – jeux de barres Neutre et Terre

- 2.2 Montage PE-/PEN-Sammelschienensystem
- 2.2 Fitting the PE/PEN busbar system
- 2.2 Montage des jeux de barres Terre / Terre-Neutre

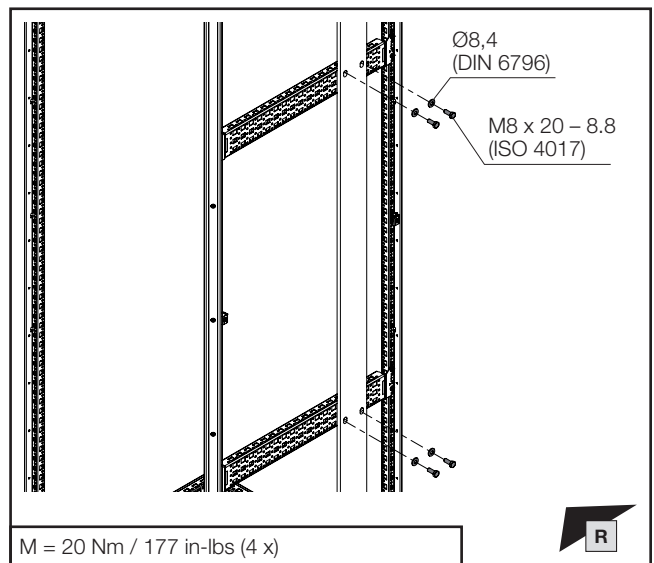
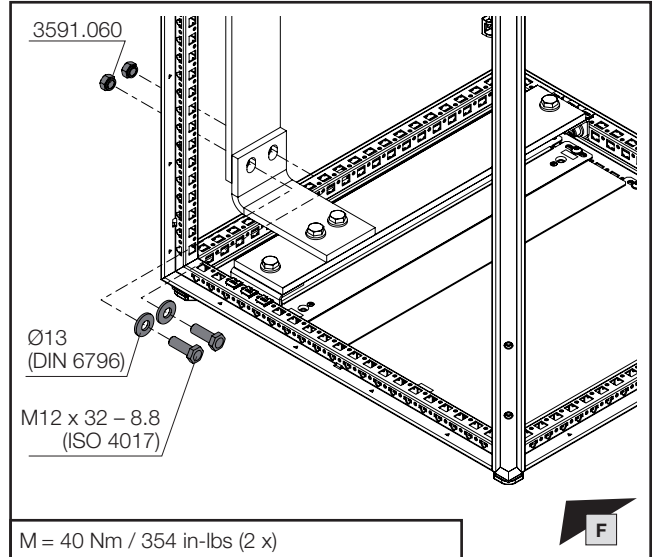
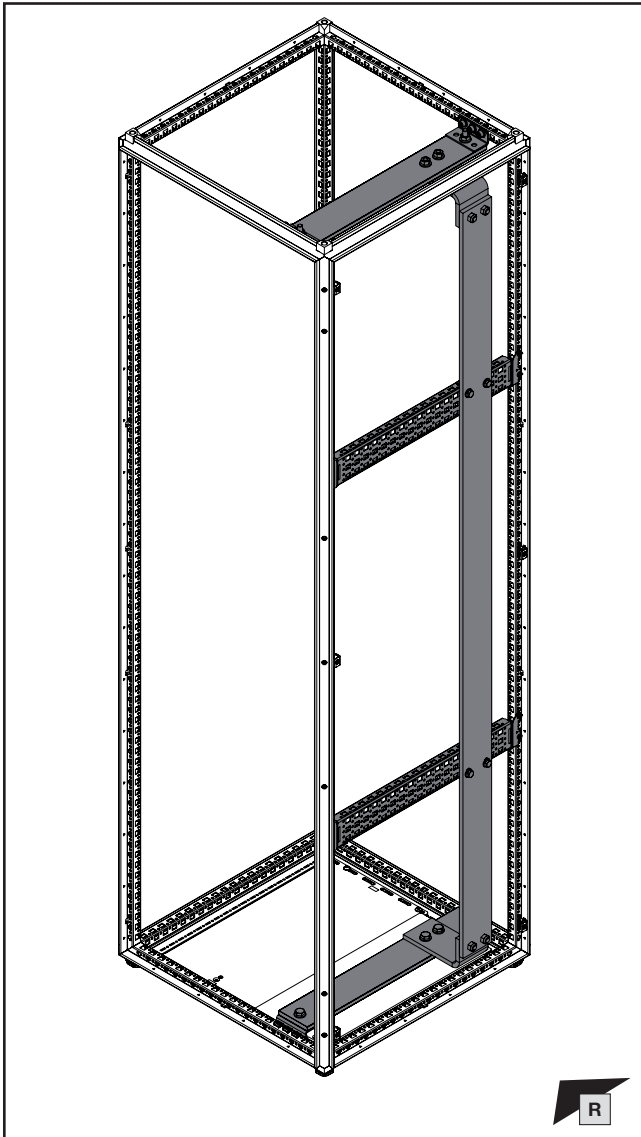

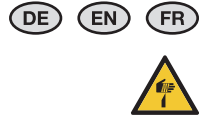
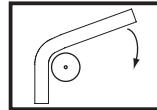
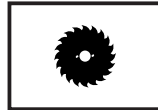
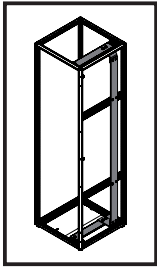

2. Montage Beispielvariante Rückbereich Mitte – Sammelschienensystem N und PE
2. Fitting for a variant example – Rear area in the centre, busbar system N and PE
2. Exemple du montage au milieu à l'arrière – jeux de barres Neutre et Terre

- 2.2 Montage PE-/PEN-Sammelschienensystem
- 2.2 Fitting the PE/PEN busbar system
- 2.2 Montage des jeux de barres Terre / Terre-Neutre

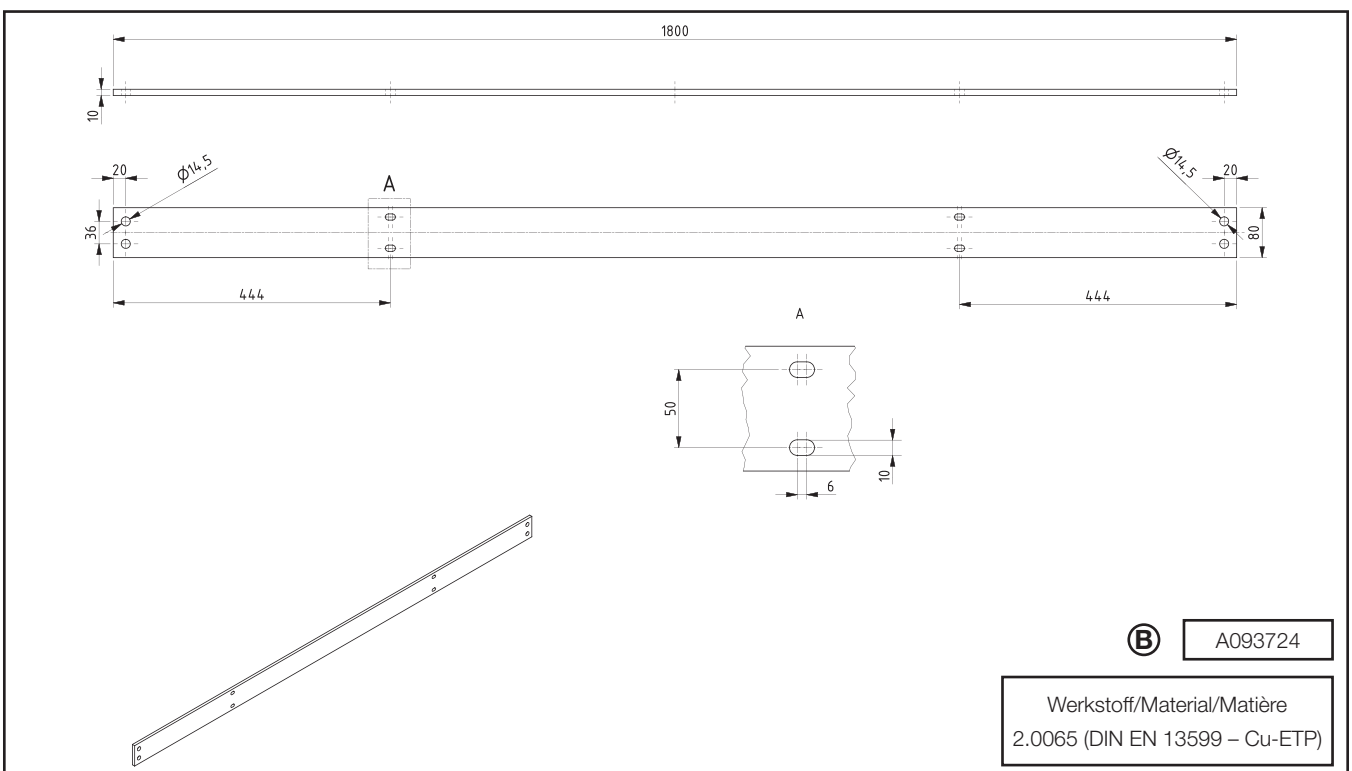
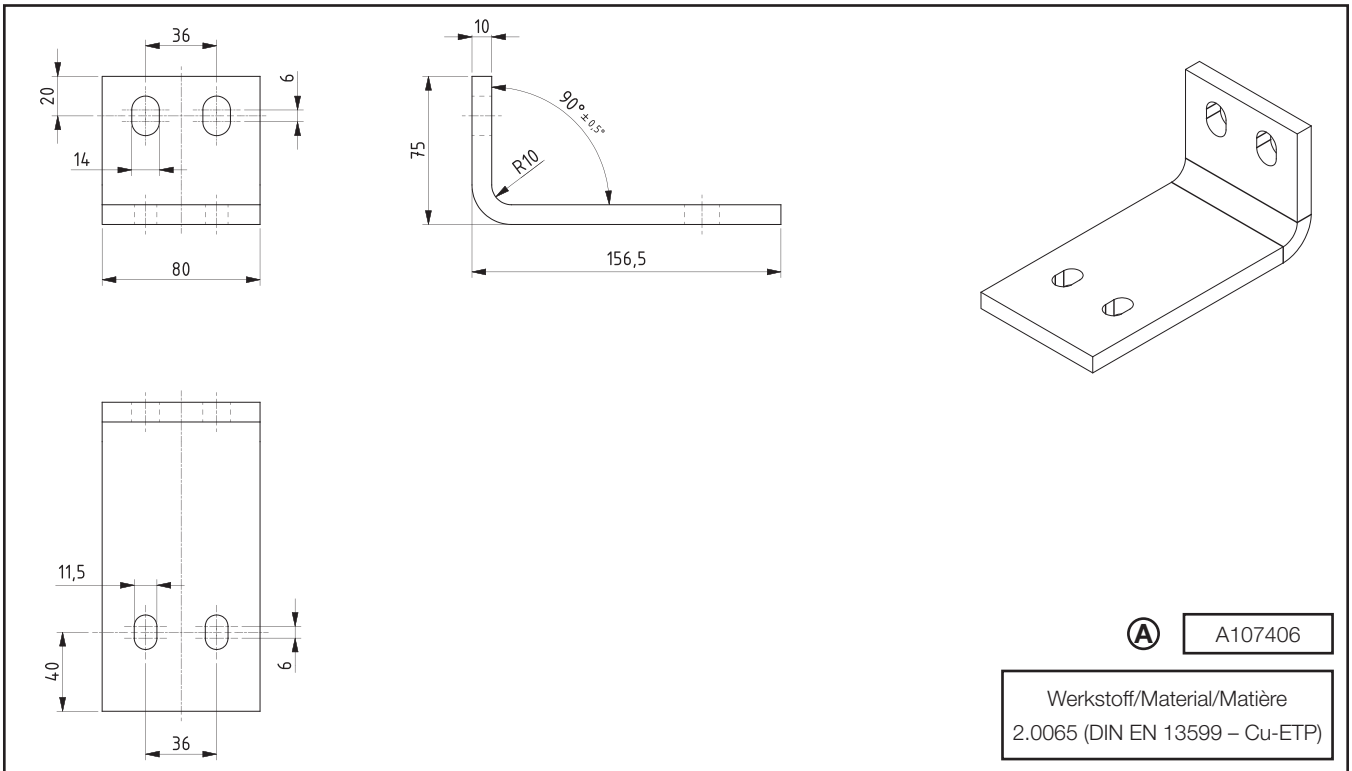

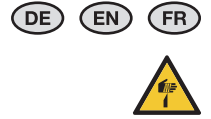
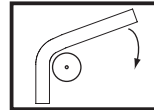
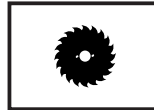
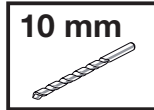
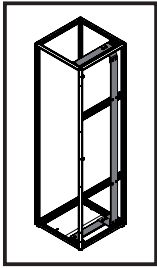

2. Montage Beispielvariante Rückbereich Mitte – Sammelschienensystem N und PE
2. Fitting for a variant example – Rear area in the centre, busbar system N and PE
2. Exemple du montage au milieu à l'arrière – jeux de barres Neutre et Terre

- 2.2 Montage PE-/PEN-Sammelschienensystem
- 2.2 Fitting the PE/PEN busbar system
- 2.2 Montage des jeux de barres Terre / Terre-Neutre

Alternativ zu 2 x (A) und 1 x (B)

Alternative to 2 x (A) and 1 x (B)

En alternative à 2 x (A) et 1 x (B)

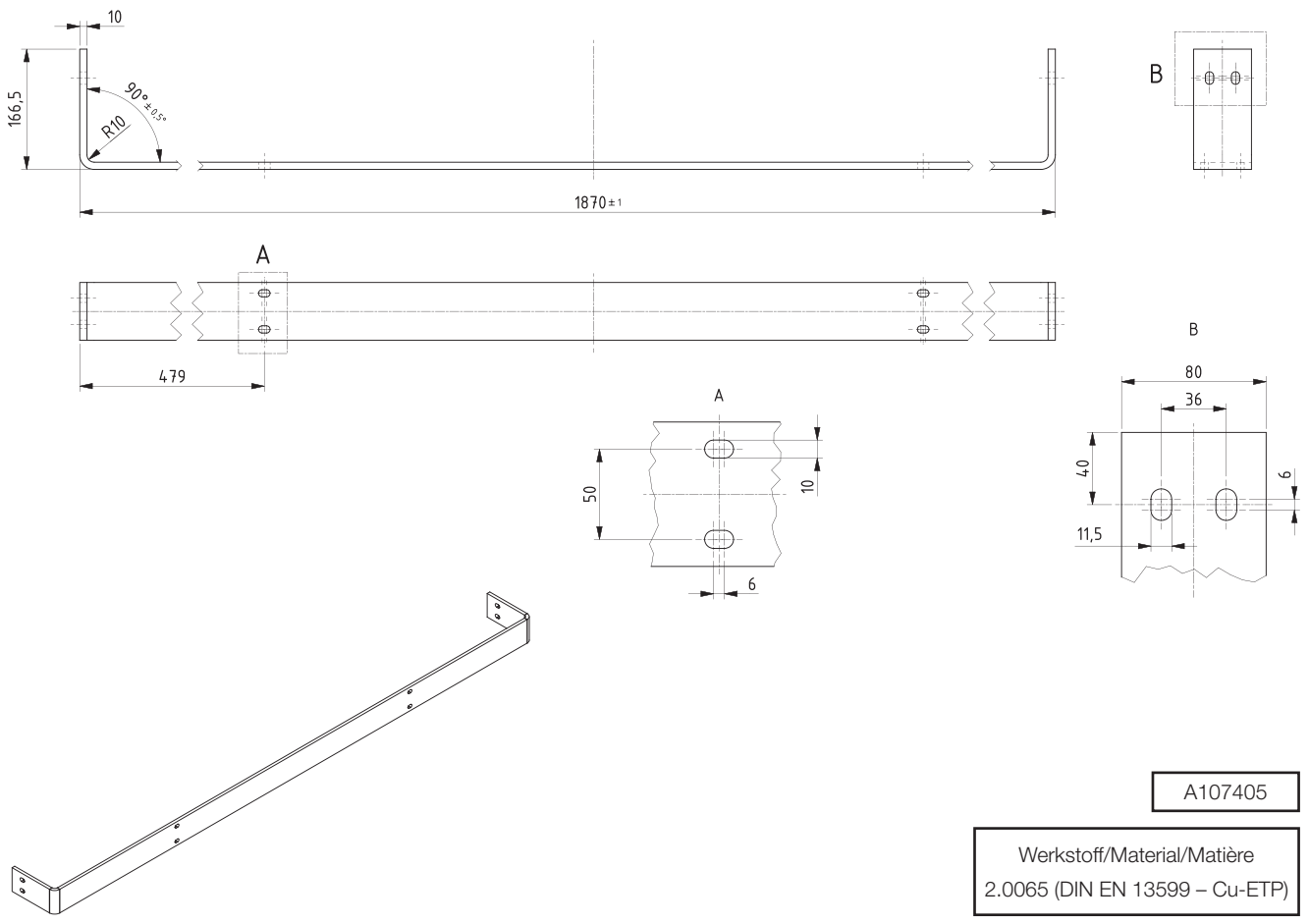

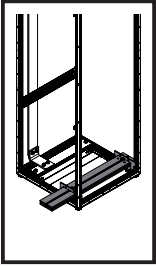

2. Montage Beispielvariante Rückbereich Mitte – Sammelschienensystem N und PE
2. Fitting for a variant example – Rear area in the centre, busbar system N and PE
2. Exemple du montage au milieu à l'arrière – jeux de barres Neutre et Terre

- 2.3 Montage des N-Sammelschienensystems
- 2.3 Fitting the N busbar system
- 2.3 Montage des jeux de barres Neutre

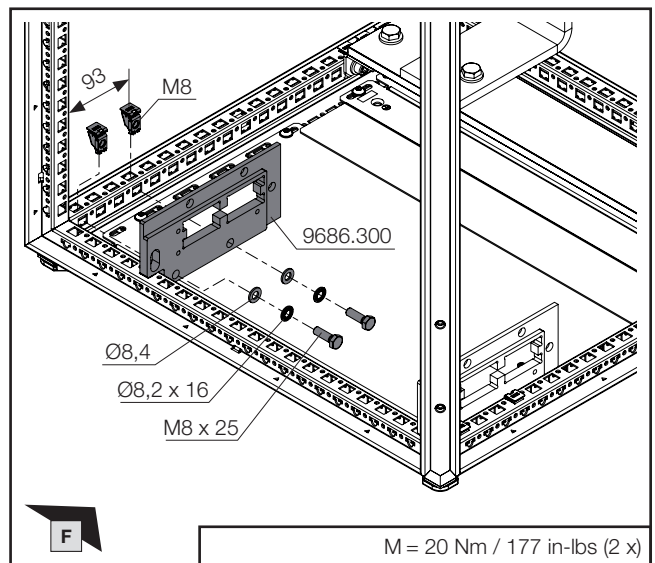
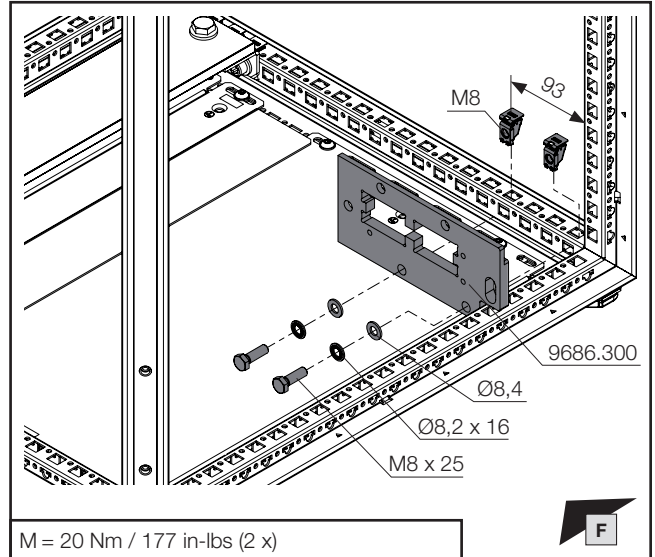
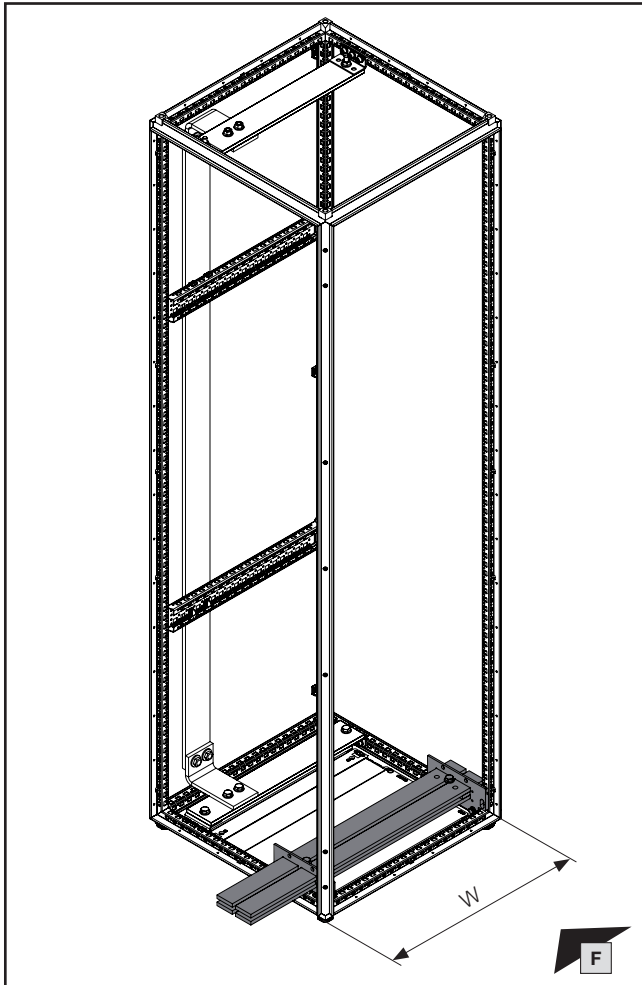

Montageanleitung VX25 Ri4Power – Schalt- und Energieverteilanlagen-System
 Assembly instructions VX25 Ri4Power – Switchgear and power distribution system
 Notice de montage VX25 Ri4Power – Distribution de courant

DE/EN/FR

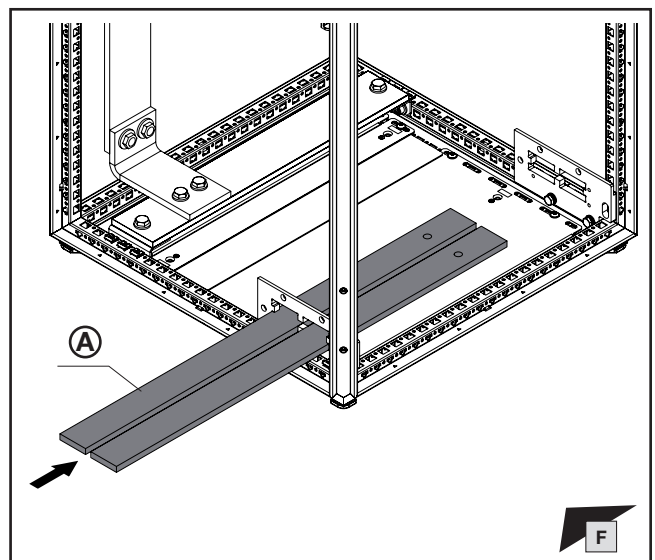
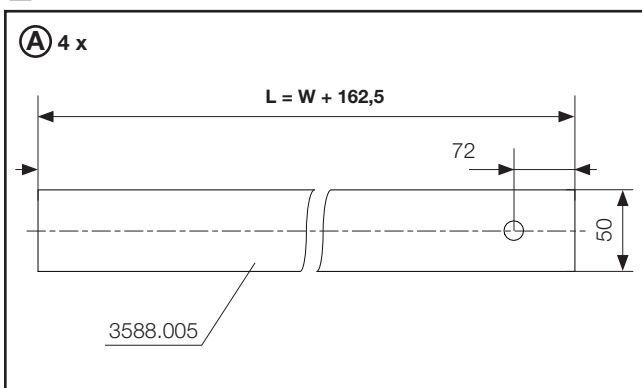

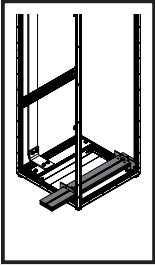

SW16/
SW17

DE EN FR



2. Montage Beispielvariante Rückbereich Mitte – Sammelschienensystem N und PE
2. Fitting for a variant example – Rear area in the centre, busbar system N and PE
2. Exemple du montage au milieu à l'arrière – jeux de barres Neutre et Terre

- 2.3 Montage des N-Sammelschienensystems
- 2.3 Fitting the N busbar system
- 2.3 Montage des jeux de barres Neutre

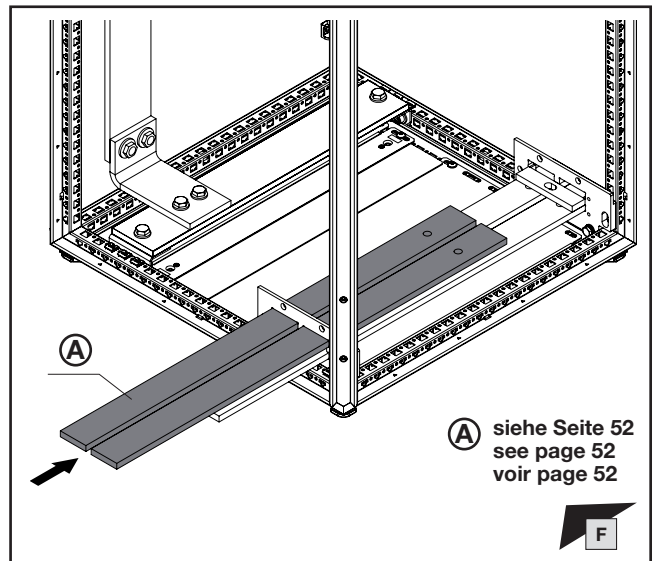
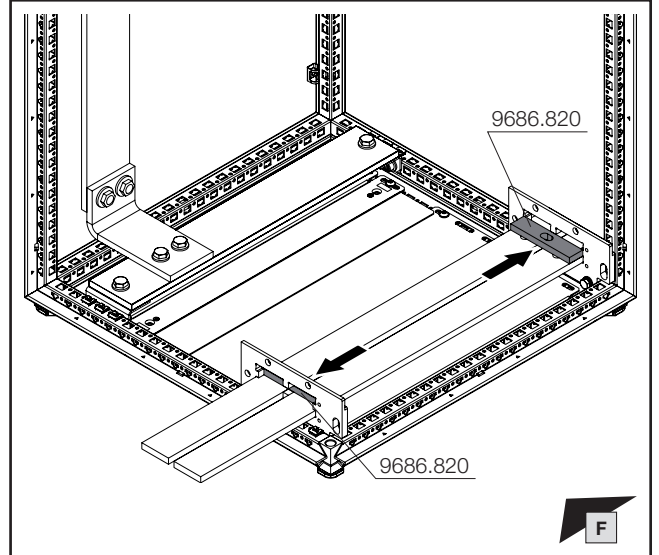
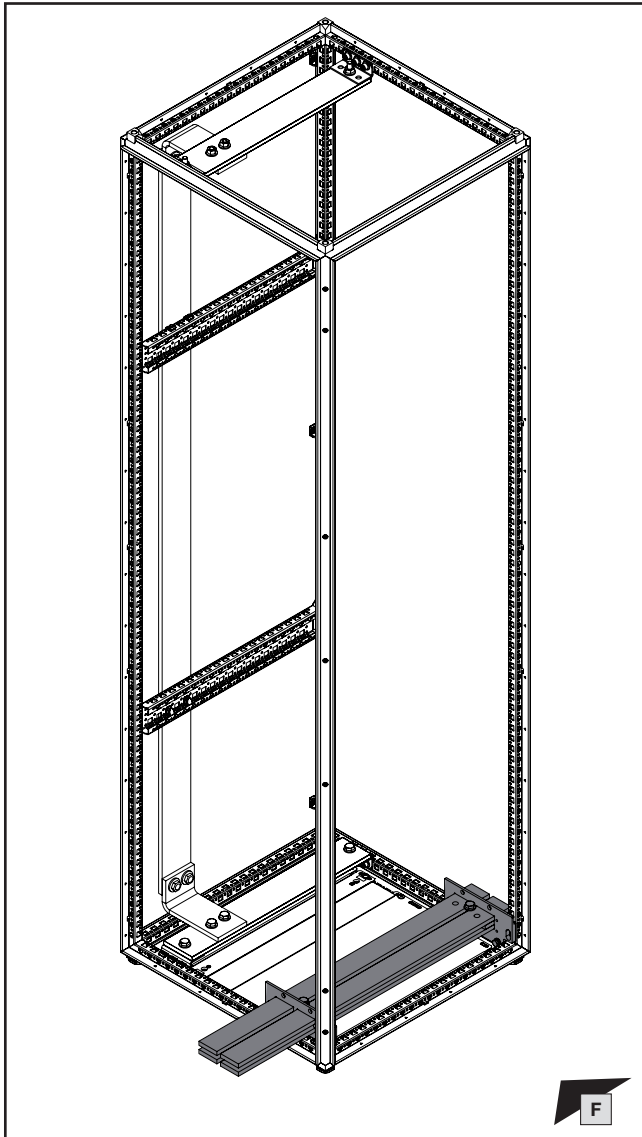

A siehe Seite 52
see page 52
voir page 52

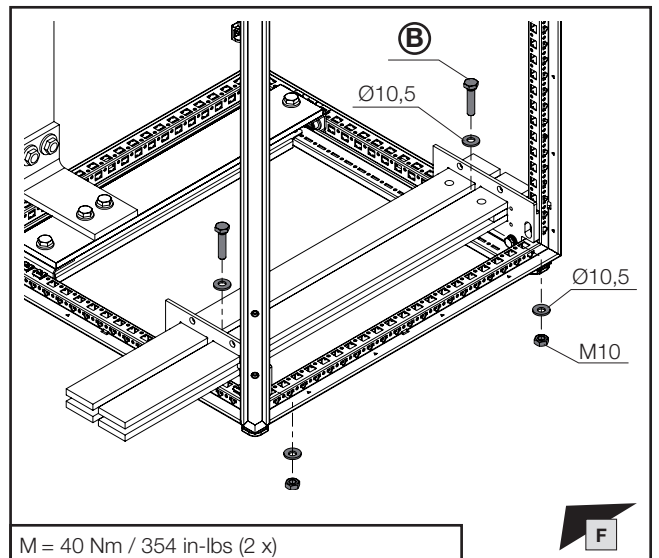

M = 40 Nm / 354 in-lbs (2 x)

Anzahl N-Sammelschienen Quantity N busbars Nombre des jeux de barres Neutre	B Best.-Nr. Model No. Référence
2	9686.830
4	9686.845

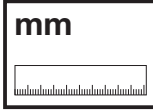
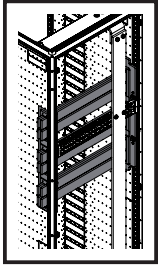

DE EN FR



2. Montage Beispielvariante Rückbereich Mitte – Sammelschienensystem N und PE
2. Fitting for a variant example – Rear area in the centre, busbar system N and PE
2. Exemple du montage au milieu à l'arrière – jeux de barres Neutre et Terre

- 2.4 Montage des rückwärtigen Hauptschienensystems
- 2.4 Mounting the rear main busbar system
- 2.4 Montage des jeux de barres principaux à l'arrière

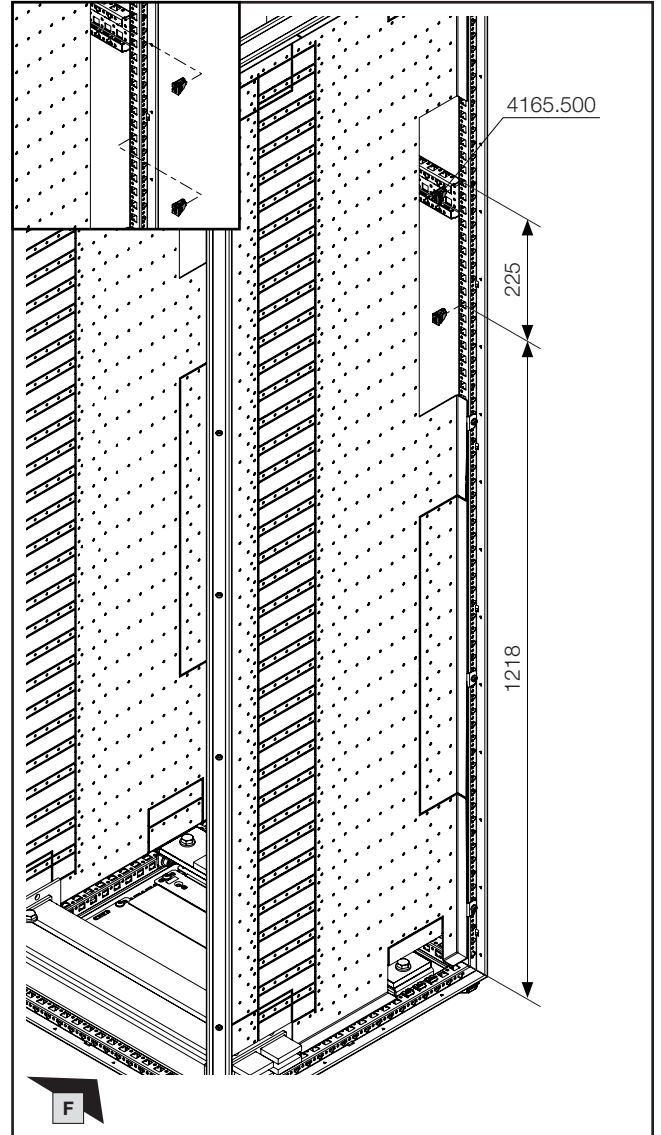
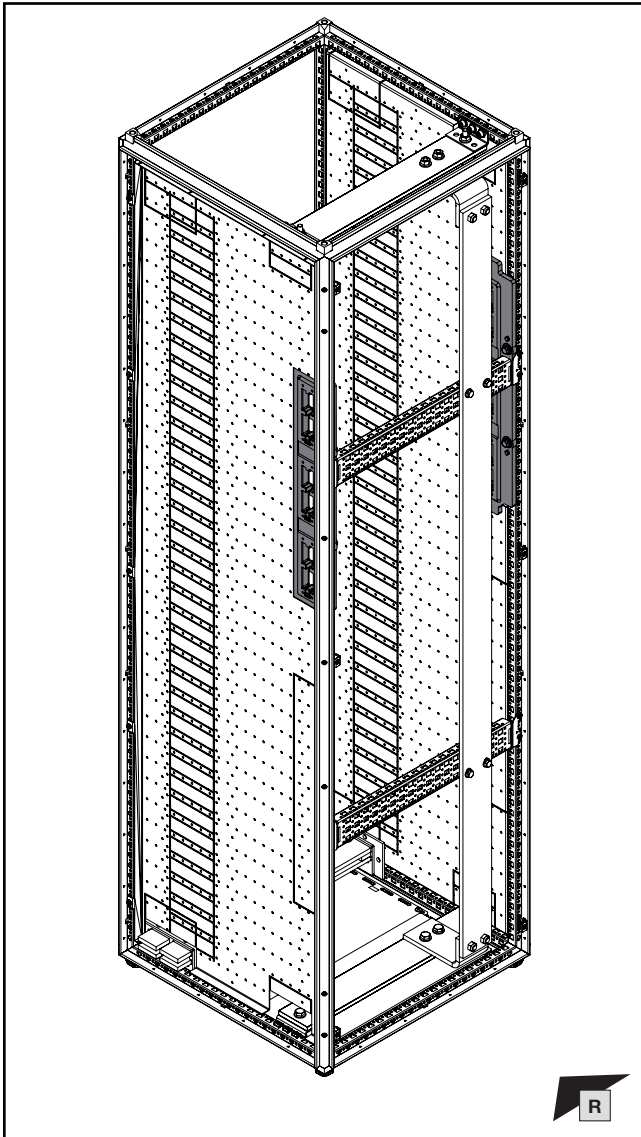

Montageanleitung VX25 Ri4Power – Schalt- und Energieverteilanlagen-System

Assembly instructions VX25 Ri4Power – Switchgear and power distribution system

Notice de montage VX25 Ri4Power – Distribution de courant

DE/EN/FR



Hinweis / Note / Remarque

Für Schutzeigenschaft Störlichtbogenklasse B Montagerihenfolge in den entsprechenden Abschnitten der o. g. Anleitung beachten.

For arcing class B protection, please follow the assembly sequence as set out in the relevant chapters of the aforementioned assembly instructions.

Pour la protection contre les arcs électriques de catégorie B, suivez la séquence de montage indiquée dans les sections correspondantes des instructions ci-dessus.

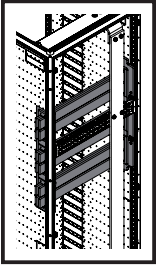

SW13



DE EN FR



2. Montage Beispielvariante Rückbereich Mitte – Sammelschienensystem N und PE
2. Fitting for a variant example – Rear area in the centre, busbar system N and PE
2. Exemple du montage au milieu à l'arrière – jeux de barres Neutre et Terre

- 2.4 Montage des rückwärtigen Hauptschienensystems
- 2.4 Mounting the rear main busbar system
- 2.4 Montage des jeux de barres principaux à l'arrière

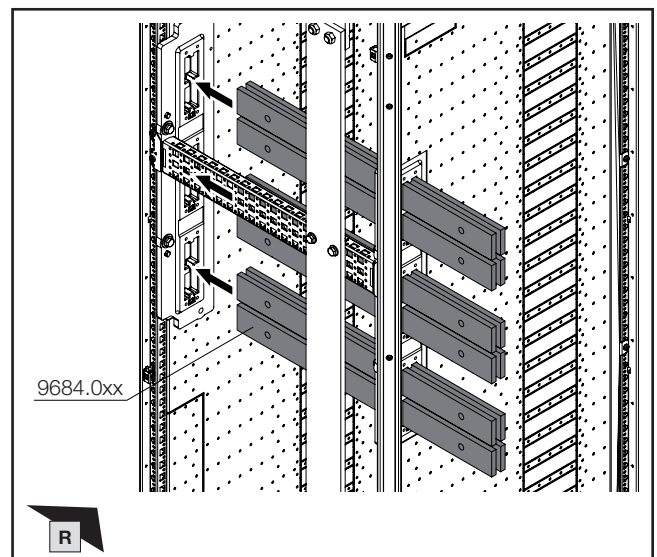
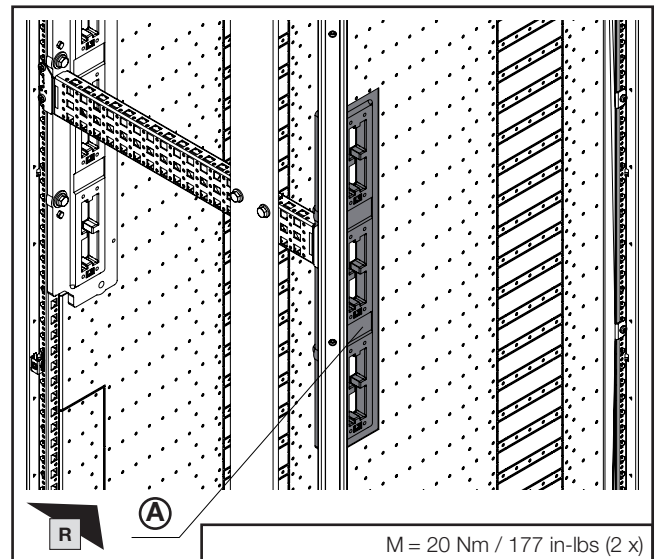
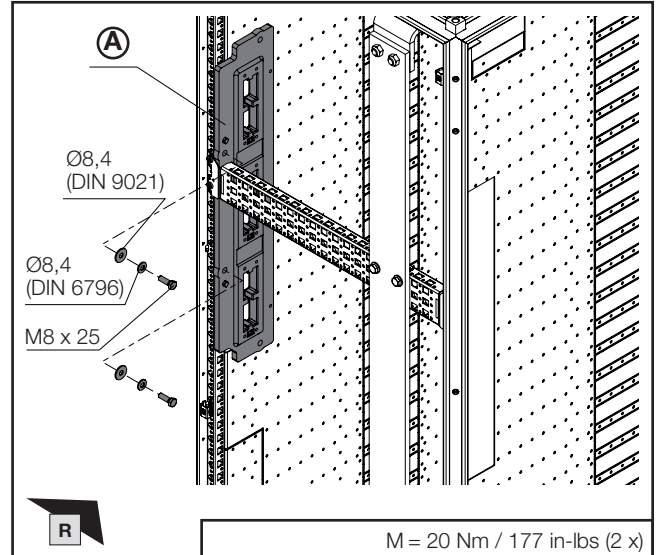
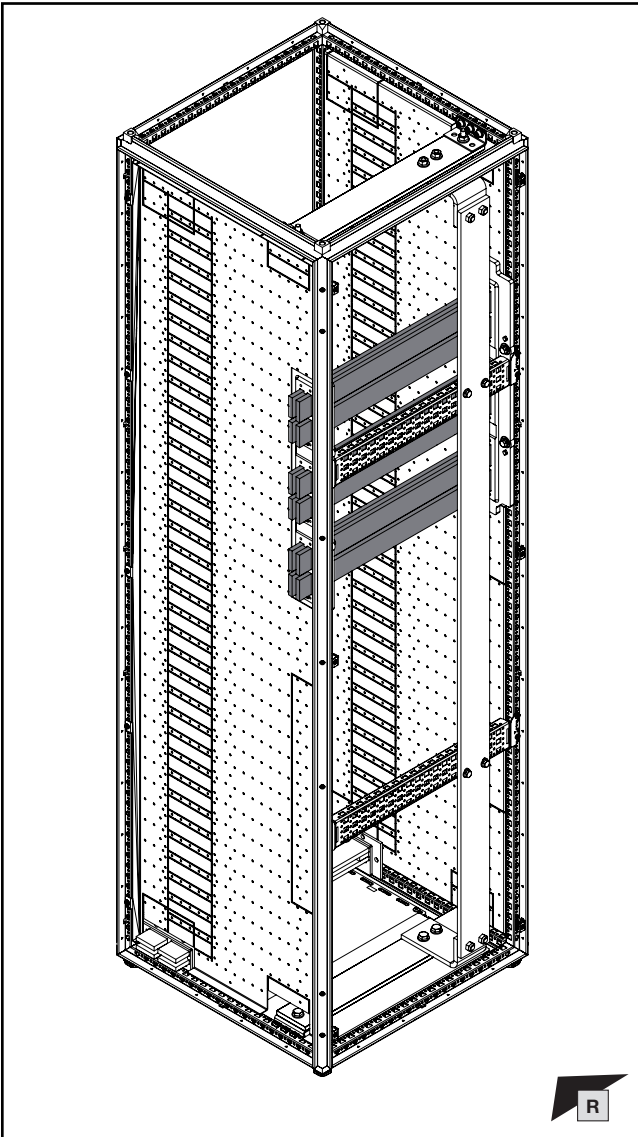

Sammelschiene Abmessung mm Busbar dimensions mm Dimensions de la barre mm	Anreihung Baying Juxtaposition	Best.-Nr. Model No. Référence
50 x 10	✓	9686.060
50 x 10	✗	9686.070

Montageanleitung VX25 Ri4Power – Schalt- und Energieverteilanlagen-System

Assembly instructions VX25 Ri4Power – Switchgear and power distribution system

Notice de montage VX25 Ri4Power – Distribution de courant

DE/EN/FR

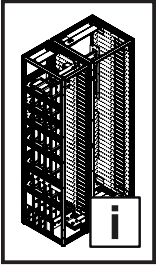

- 3. Verbindung Hochführungsfeld und Beispielvariante Rückbereich Mitte
- 3. Connecting the riser section and the variant example for the rear area, centre
- 3. Raccordement zone de cheminement vertical et exemple de variante au milieu à l'arrière

- 3.1 Verbindung des Hochführungsfelds und der Beispielvariante Rückbereich Mitte
- 3.1 Connecting the riser section and the variant example for the rear area, centre
- 3.1 Raccordement de la zone de cheminement vertical et de l'exemple de variante au milieu à l'arrière

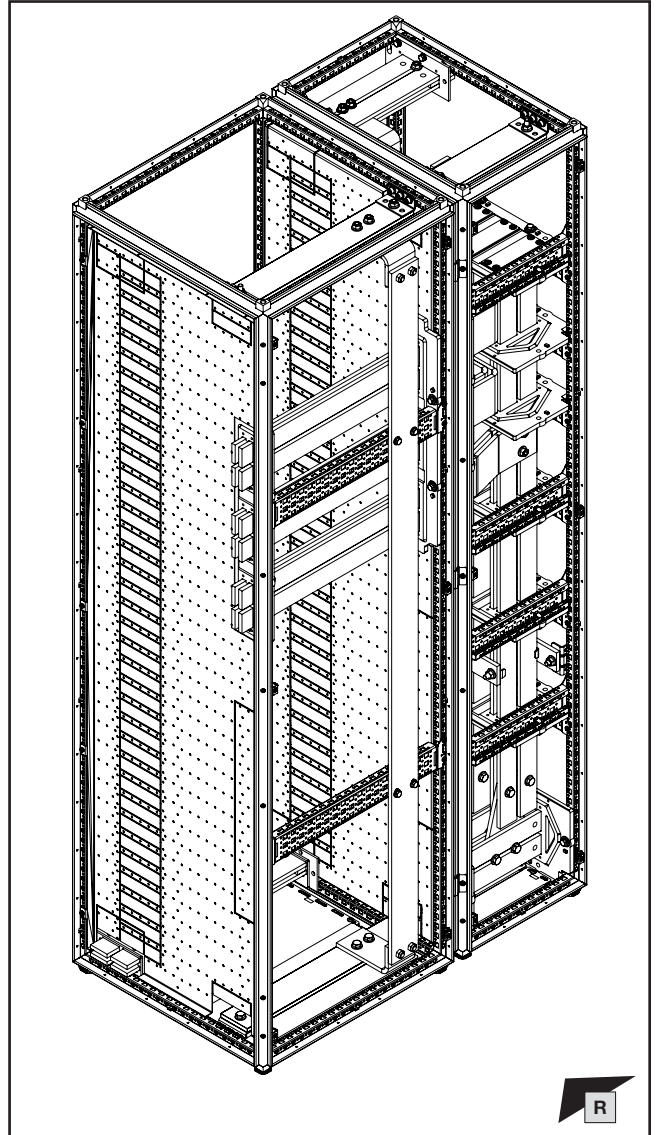
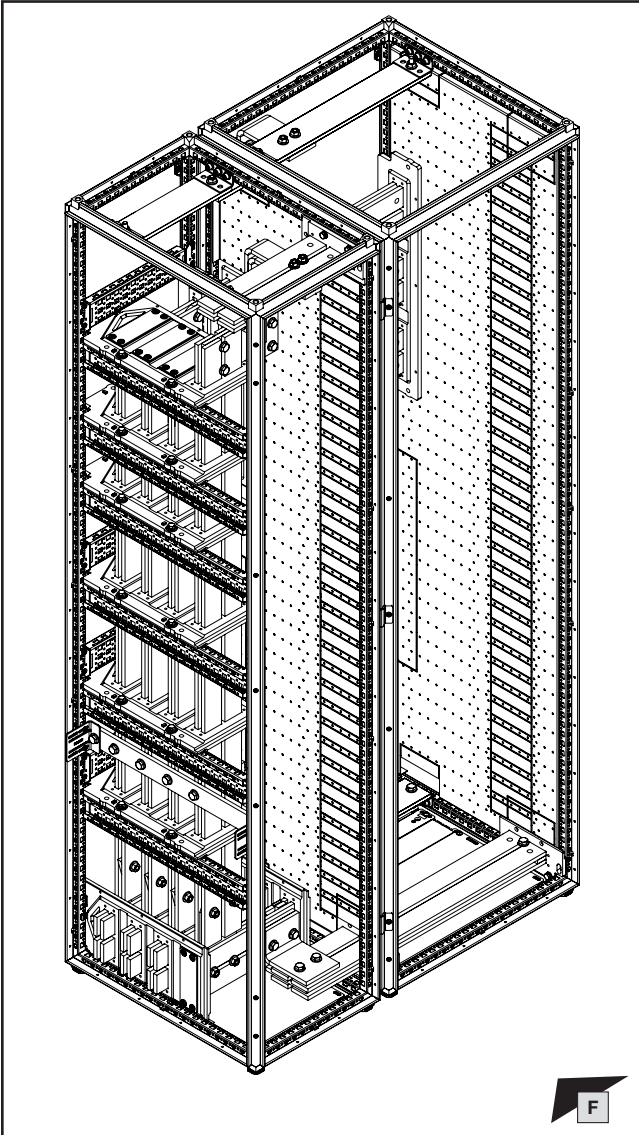

Hinweis / Note / Remarque

Der weitere Aufbau der Schaltanlage entspricht einer prinzipiellen Montagereihenfolge in der Werkstatt. Für das Aufstellen/Verbinden der Anlagenfelder bei Kapitel 4.1 weiter fortfahren.

Subsequent switchgear assembly follows the general assembly sequence in the workshop. Continue with chapter 4.1 on positioning and connecting the system sections.

La suite du montage de l'installation de distribution électrique est conforme à l'ordre de montage habituel à l'atelier. Poursuivre au chapitre 4.1 pour l'installation / la connexion des zones.

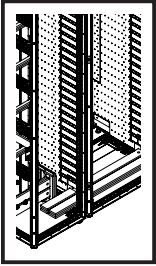

- 3. Verbindung Hochführungsfeld und Beispielvariante Rückbereich Mitte
- 3. Connecting the riser section and the variant example for the rear area, centre
- 3. Raccordement zone de cheminement vertical et exemple de variante au milieu à l'arrière

- 3.2 Zusammenfügen der Schaltanlagenfelder – Montage der Anreihverbinder
- 3.2 Joining the switchgear sections together – Fitting the baying connectors
- 3.2 Assemblage des différentes cellules de distribution électrique – montage des attaches de juxtaposition

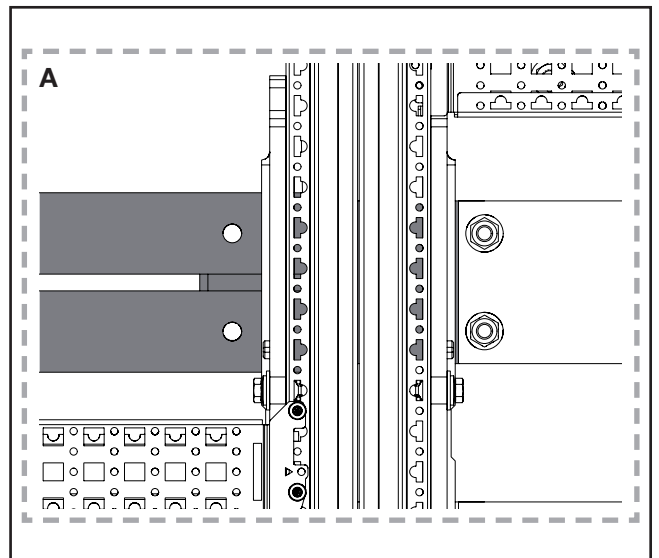
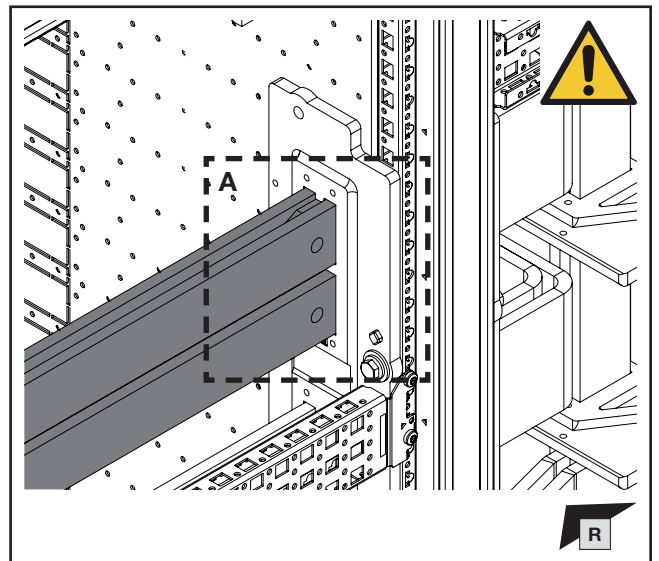
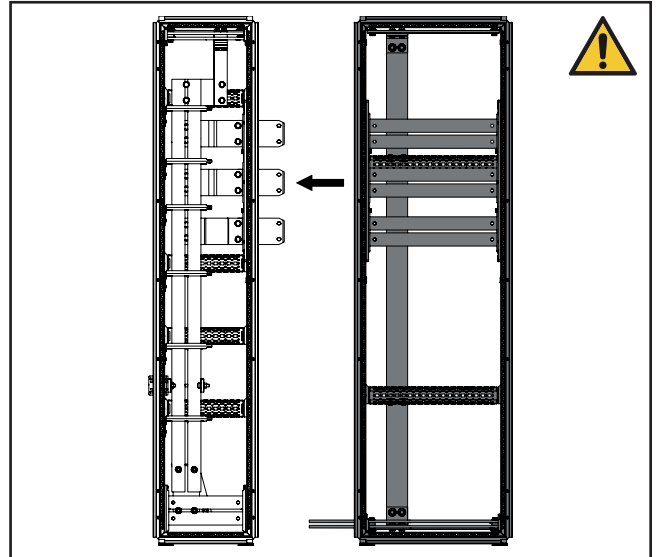
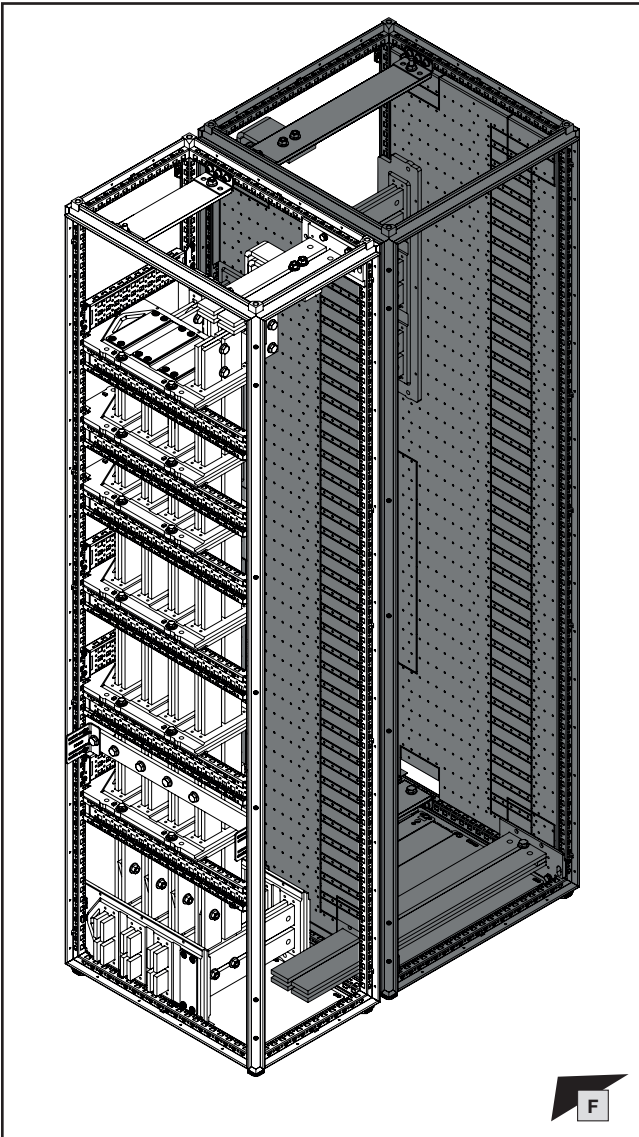

Hinweis / Note / Remarque

Beim Zusammenfügen der beiden Schaltanlagenfelder ggf. Schrauben lösen, um das Einschieben des Längsverbinders zu erleichtern. Ansonsten können die HSS-Systeme beschädigt werden.

When joining the two switchgear sections together, loosen the screws if necessary to make insertion of the longitudinal connector easier. Otherwise the MBS systems may be damaged.

Desserrer si nécessaire les vis pour faciliter l'insertion des éléments de jonction longitudinaux lors de l'assemblage des deux zones de distribution électrique. Les jeux de barres principaux pourraient sinon être endommagés.

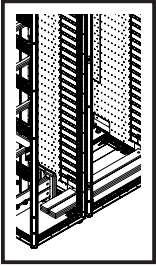

TX30



DE EN FR



- 3. Verbindung Hochführungsfeld und Beispielvariante Rückbereich Mitte
- 3. Connecting the riser section and the variant example for the rear area, centre
- 3. Raccordement zone de cheminement vertical et exemple de variante au milieu à l'arrière

- 3.2 Zusammenfügen der Schaltanlagenfelder – Montage der Anreihverbinder
- 3.2 Joining the switchgear sections together – Fitting the baying connectors
- 3.2 Assemblage des différentes cellules de distribution électrique – montage des attaches de juxtaposition

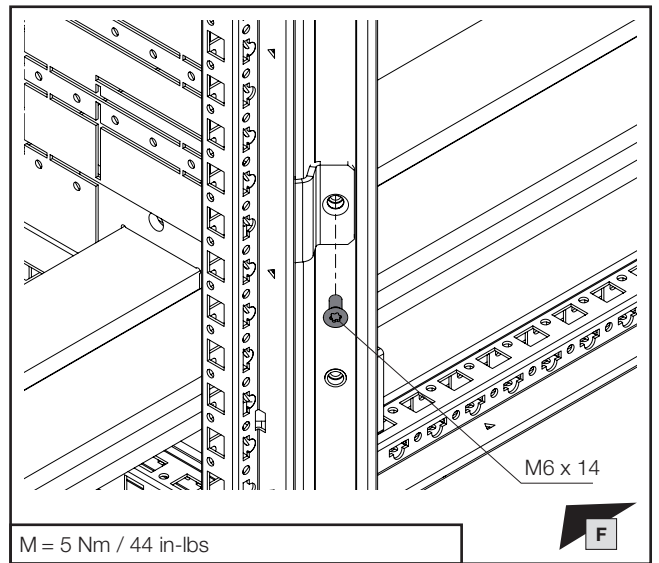
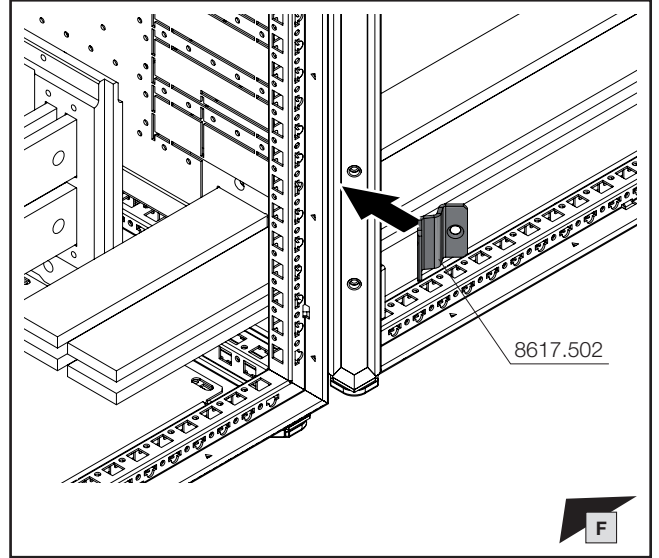
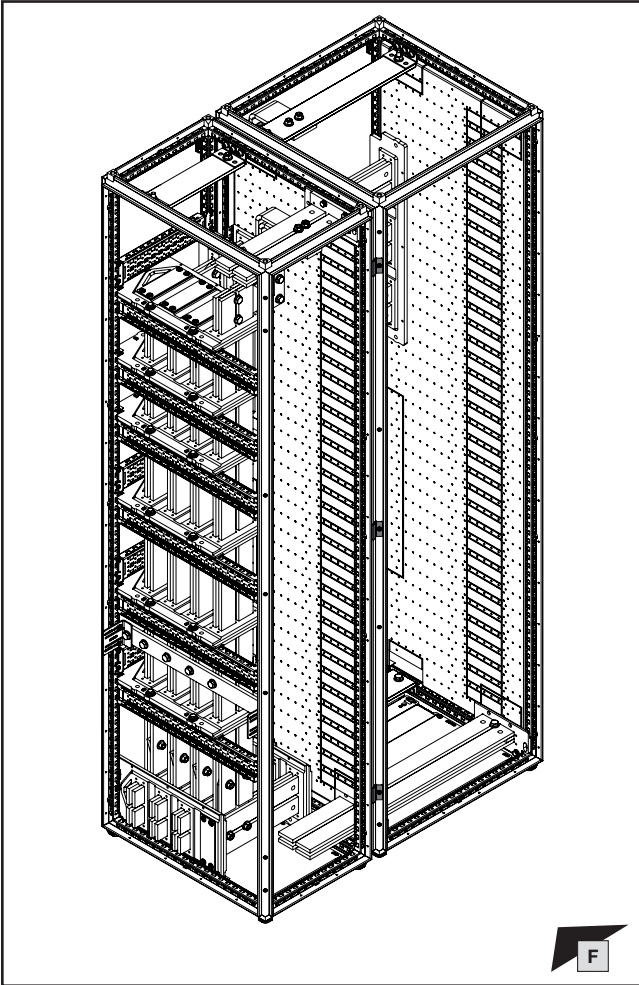

M = 5 Nm / 44 in-lbs

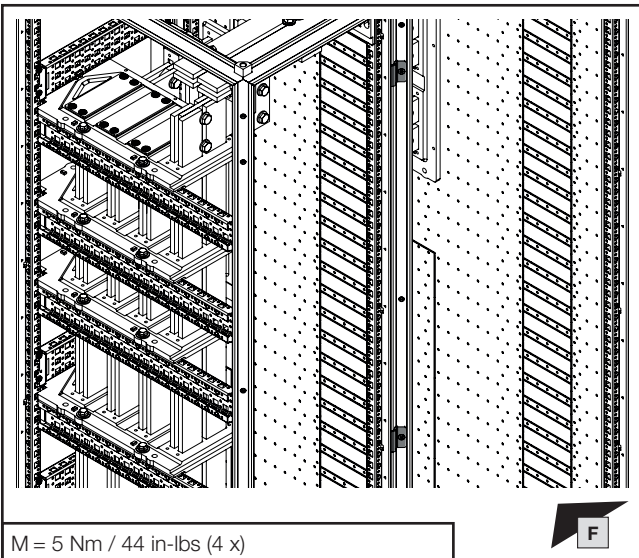

M = 5 Nm / 44 in-lbs (4 x)

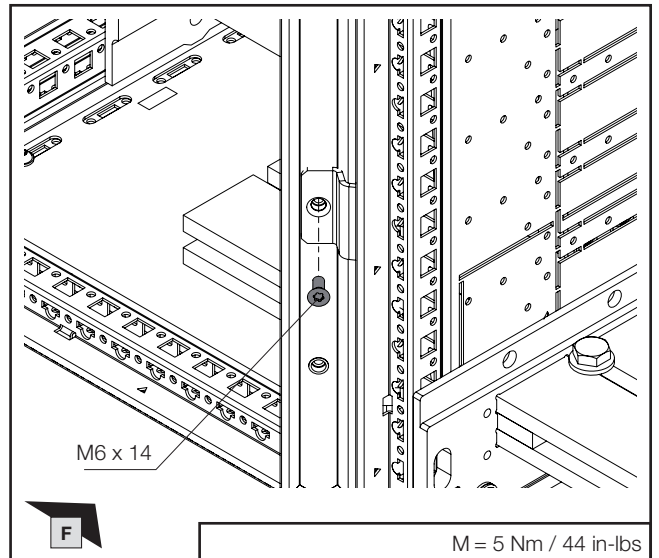

M = 5 Nm / 44 in-lbs

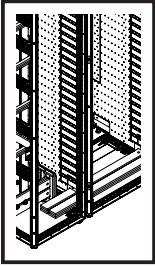

TX30



- 3. Verbindung Hochführungsfeld und Beispielvariante Rückbereich Mitte
- 3. Connecting the riser section and the variant example for the rear area, centre
- 3. Raccordement zone de cheminement vertical et exemple de variante au milieu à l'arrière

- 3.2 Zusammenfügen der Schaltanlagenfelder – Montage der Anreihverbinder
- 3.2 Joining the switchgear sections together – Fitting the baying connectors
- 3.2 Assemblage des différentes cellules de distribution électrique – montage des attaches de juxtaposition

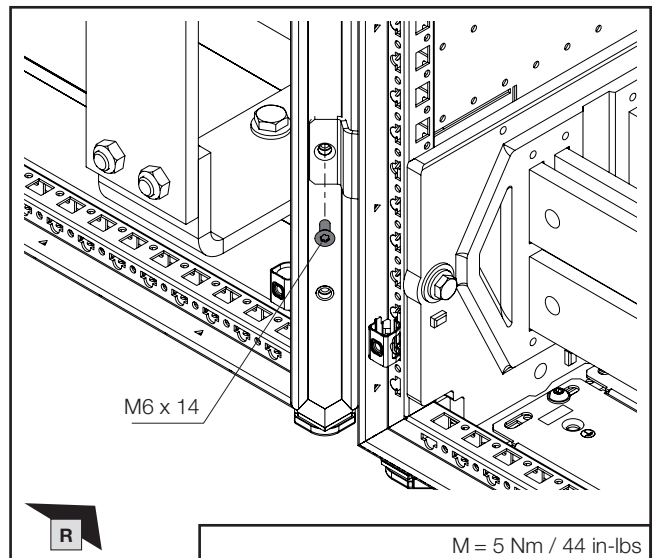
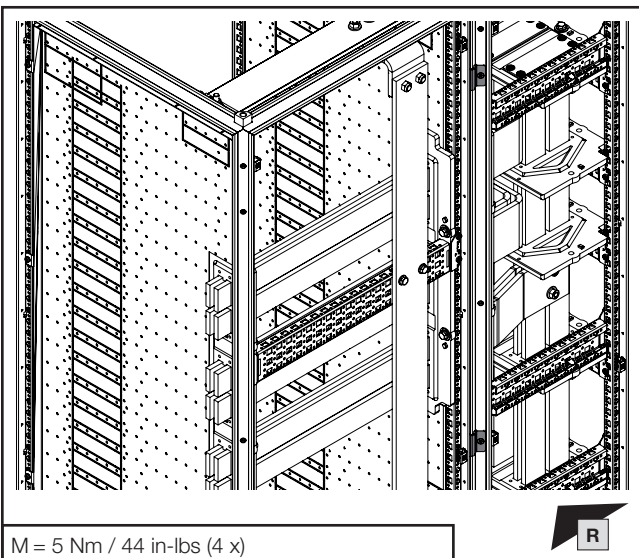
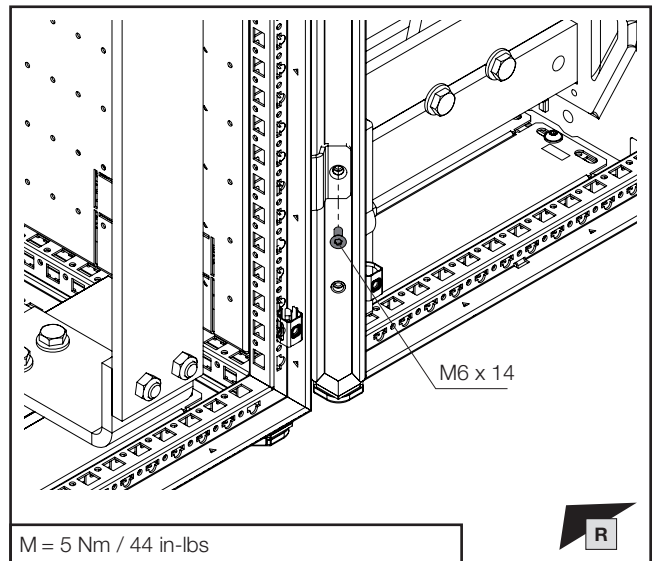
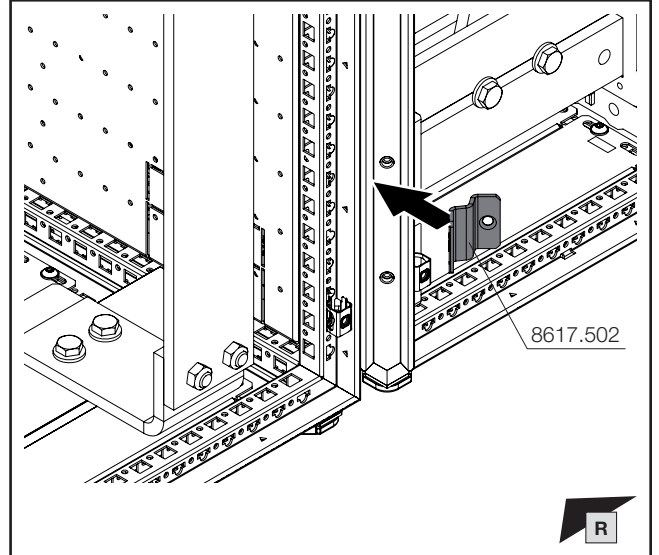
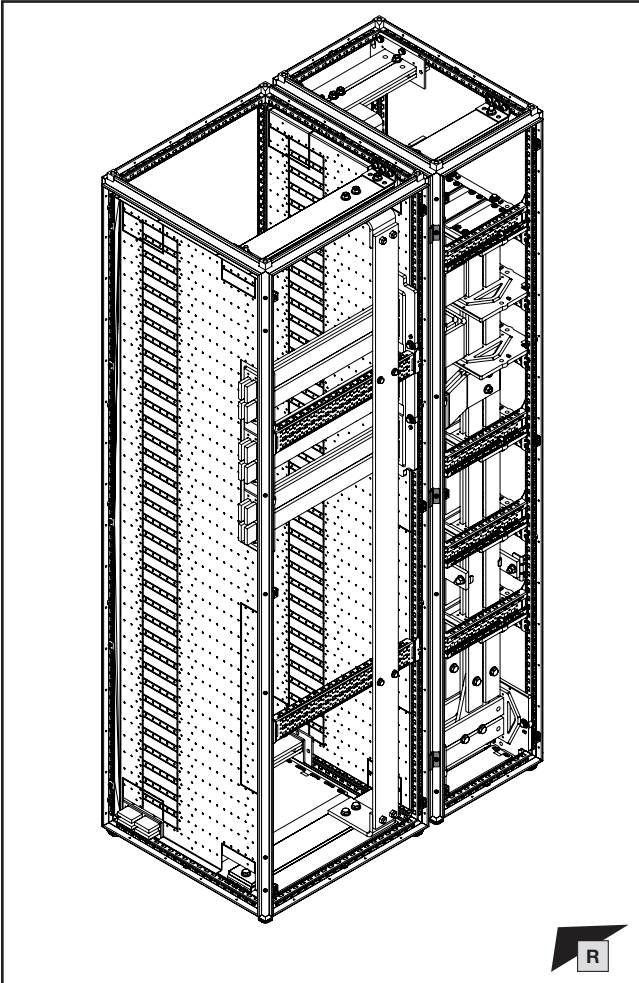

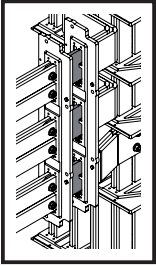

SW16/
SW17

DE EN FR



3. Verbindung Hochführungsfeld und Beispielvariante Rückbereich Mitte
3. Connecting the riser section and the variant example for the rear area, centre
3. Raccordement zone de cheminement vertical et exemple de variante au milieu à l'arrière

- 3.3 Verschrauben der Längsverbinder
- 3.3 Screw-fastening the longitudinal connectors
- 3.3 Vissage des éléments de jonction longitudinaux

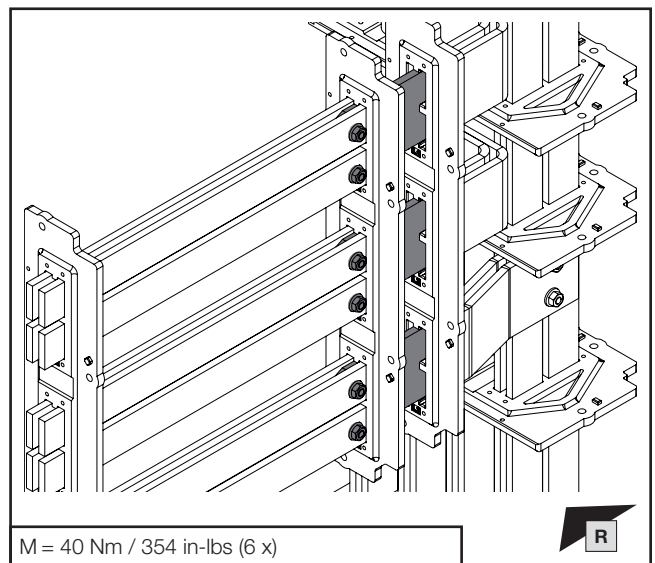
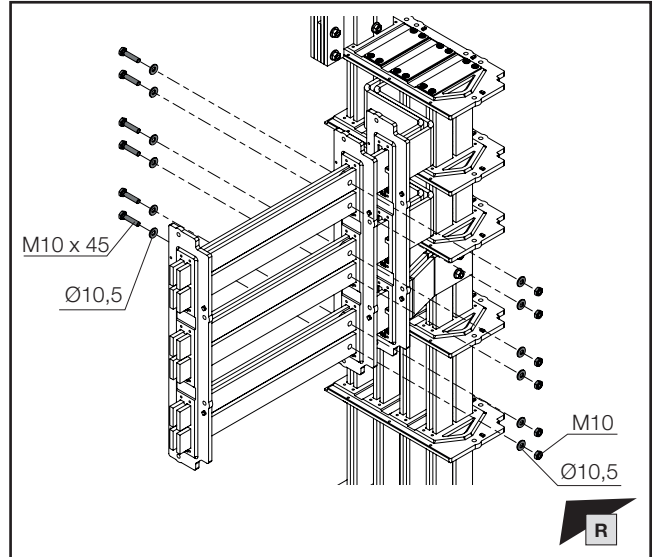
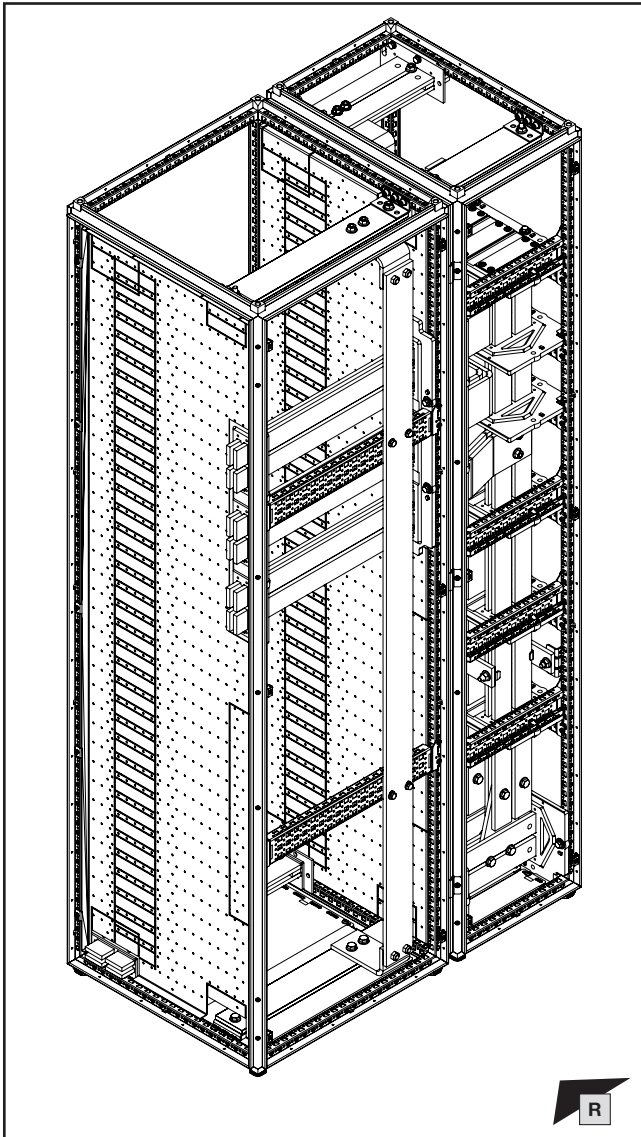

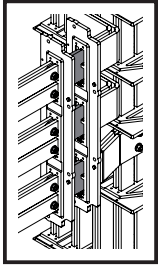

**SW16/
SW17** 

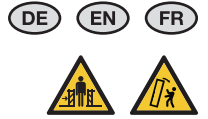

3. Verbindung Hochführungsfeld und Beispielvariante Rückbereich Mitte
3. Connecting the riser section and the variant example for the rear area, centre
3. Raccordement zone de cheminement vertical et exemple de variante au milieu à l'arrière

- 3.3 Verschrauben der Längsverbinder
- 3.3 Screw-fastening the longitudinal connectors
- 3.3 Vissage des éléments de jonction longitudinaux

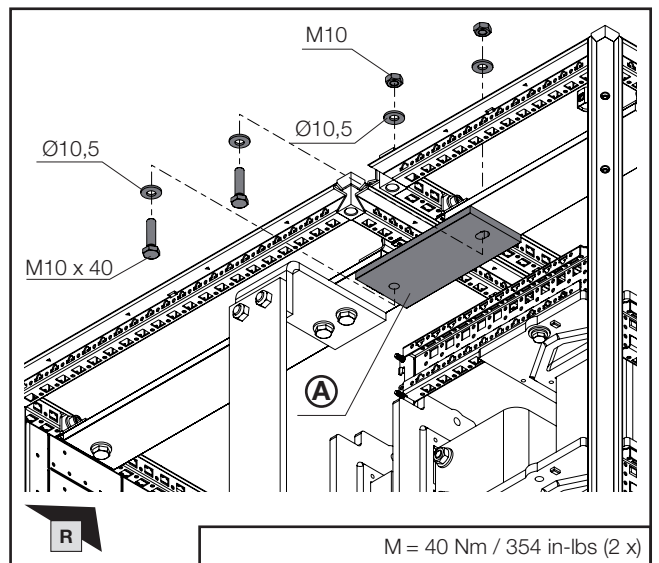
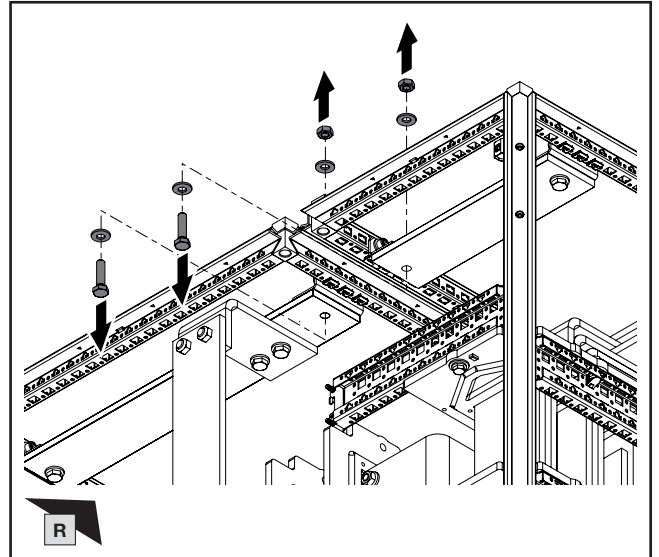
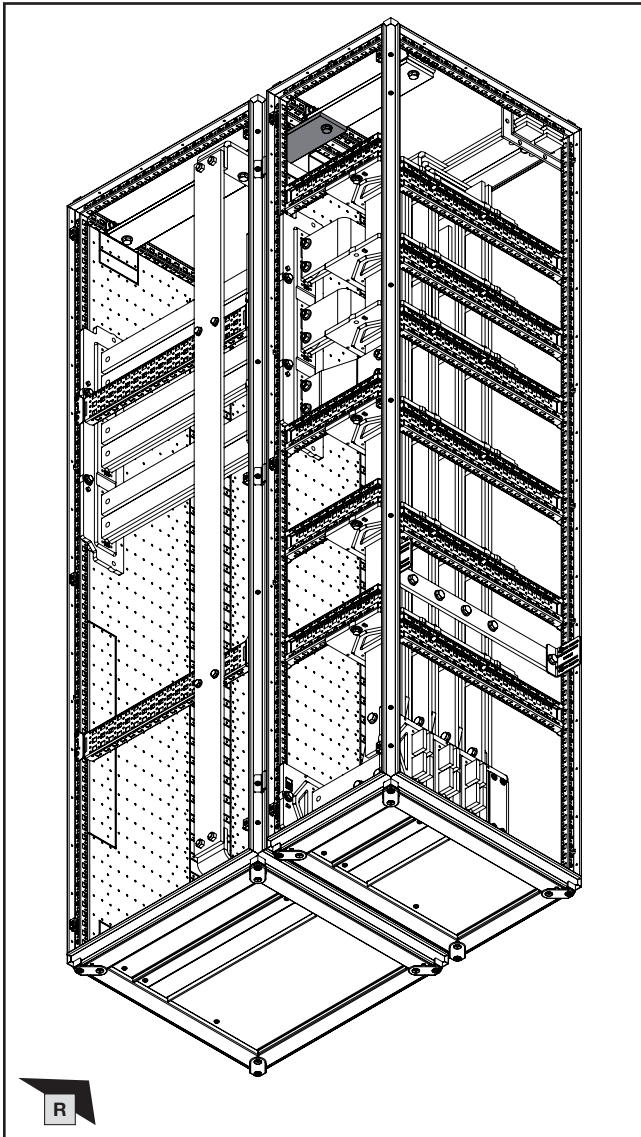

M = 40 Nm / 354 in-lbs (2 x)

Abmessungen mm Dimensions mm Dimensions mm	A Best.-Nr. Model No. Référence
30 x 5	9686.529
30 x 10	9686.539
40 x 10	9686.549
80 x 10	9686.589

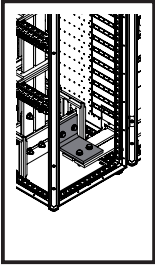

SW16/
SW17

DE EN FR



3. Verbindung Hochführungsfeld und Beispielvariante Rückbereich Mitte
3. Connecting the riser section and the variant example for the rear area, centre
3. Raccordement zone de cheminement vertical et exemple de variante au milieu à l'arrière

- 3.4 Montage Anschlusswinkel N
- 3.4 Fitting the N connection brackets
- 3.4 Montage des équerres de raccordement Neutre

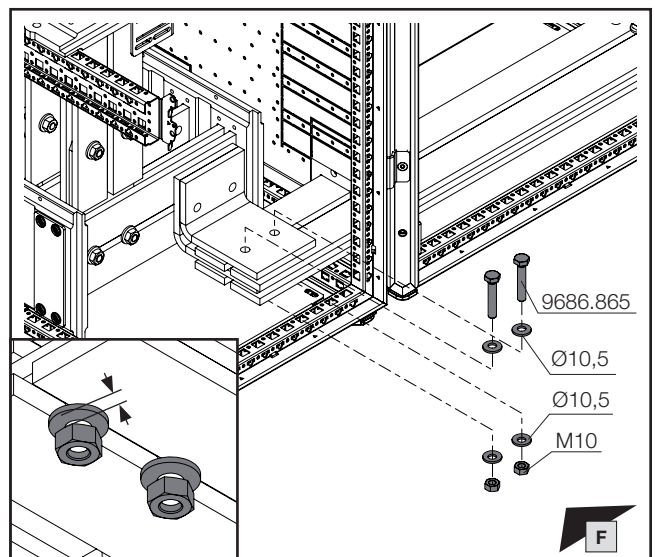
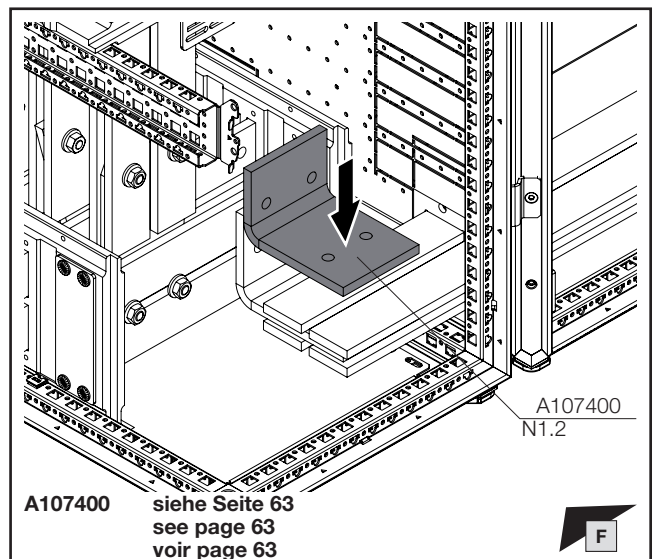
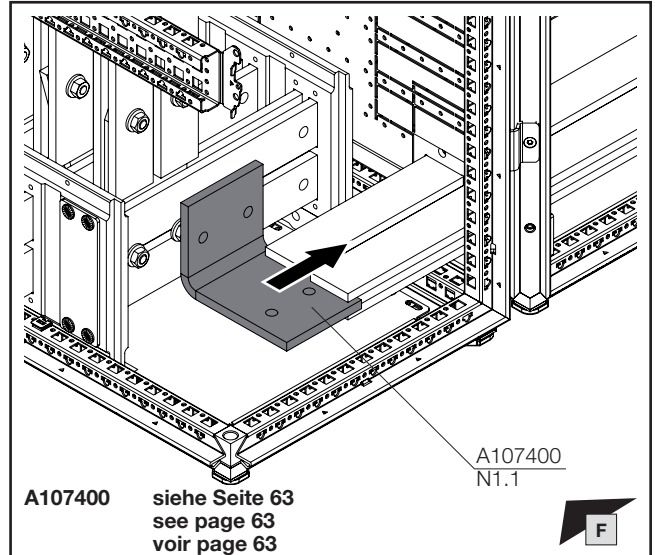
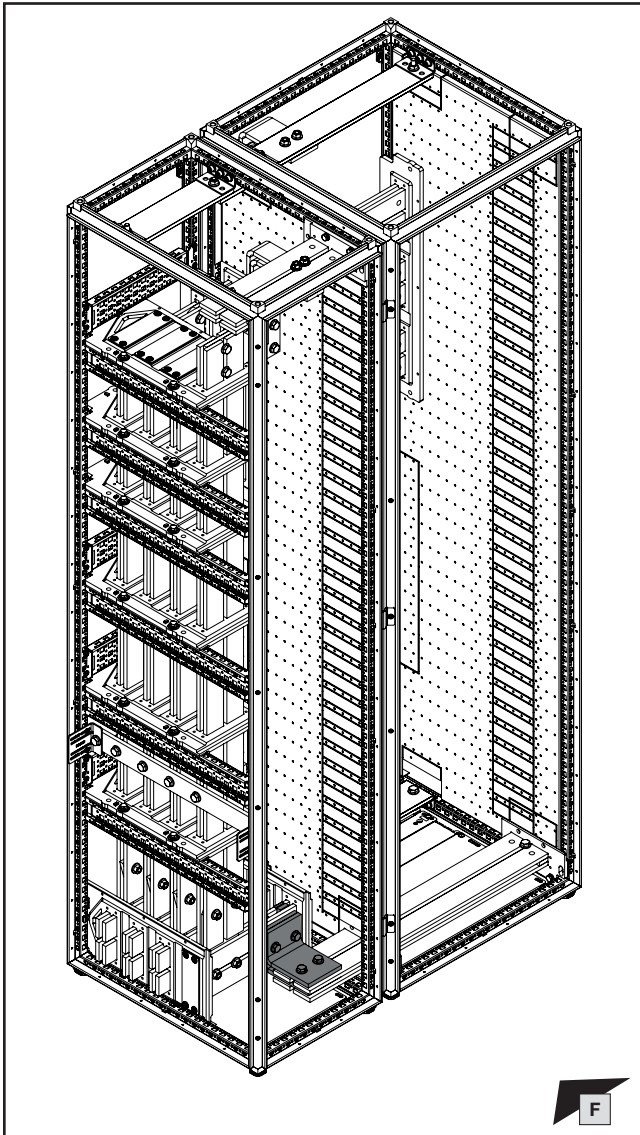

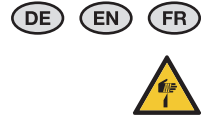
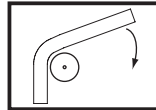
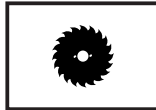
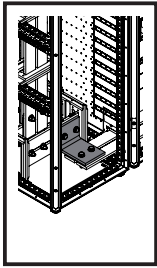

3. Verbindung Hochführungsfeld und Beispielvariante Rückbereich Mitte
 3. Connecting the riser section and the variant example for the rear area, centre
 3. Raccordement zone de cheminement vertical et exemple de variante au milieu à l'arrière

- 3.4 Montage Anschlusswinkel N
 3.4 Fitting the N connection brackets
 3.4 Montage des équerres de raccordement Neutre

A107400

Werkstoff/Material/Matière
2.0065 (DIN EN 13599 – Cu-ETP)

Ausführung Version Modèle	A mm	B mm	100 % N (4 x 50 x 10)	50 % N (2 x 50 x 10)
600_100mm_N1.1	141,5	101,5	✓	✓
600_100mm_N1.2	131,5	81,5	✓	✗
800_100mm_N1.1	341,5	101,5	✓	✓
800_100mm_N1.2	331,5	81,5	✓	✗

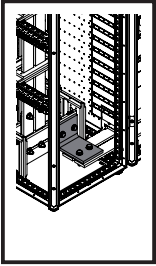

SW16/
SW17

DE EN FR



3. Verbindung Hochführungsfeld und Beispielvariante Rückbereich Mitte
3. Connecting the riser section and the variant example for the rear area, centre
3. Raccordement zone de cheminement vertical et exemple de variante au milieu à l'arrière

- 3.4 Montage Anschlusswinkel N
- 3.4 Fitting the N connection brackets
- 3.4 Montage des équerres de raccordement Neutre

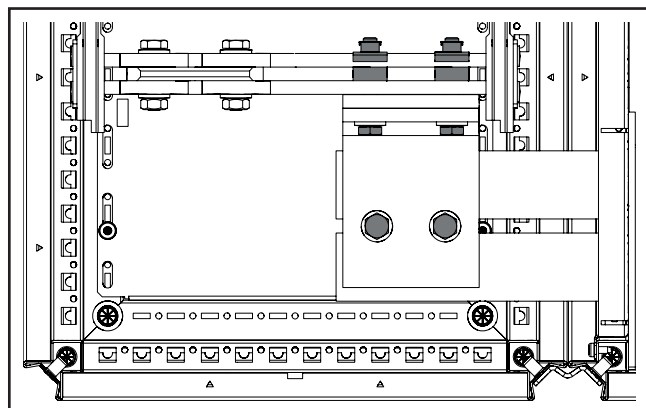
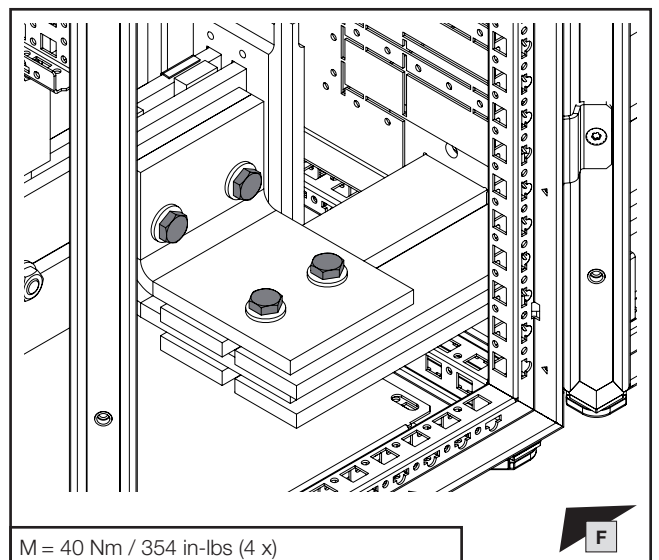
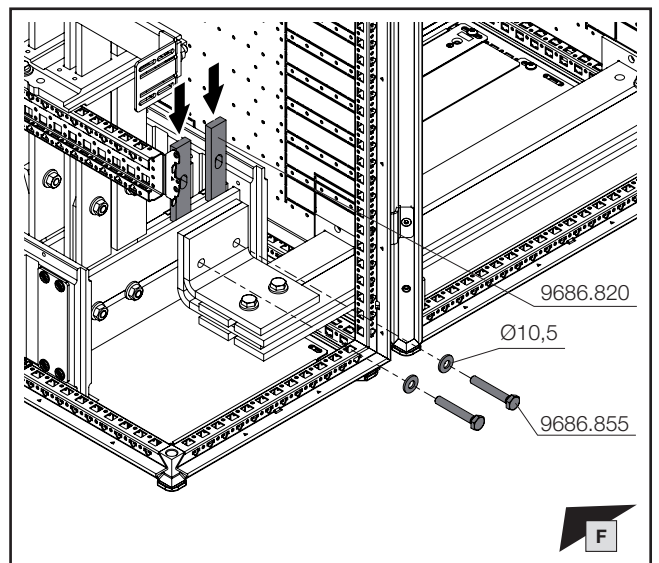
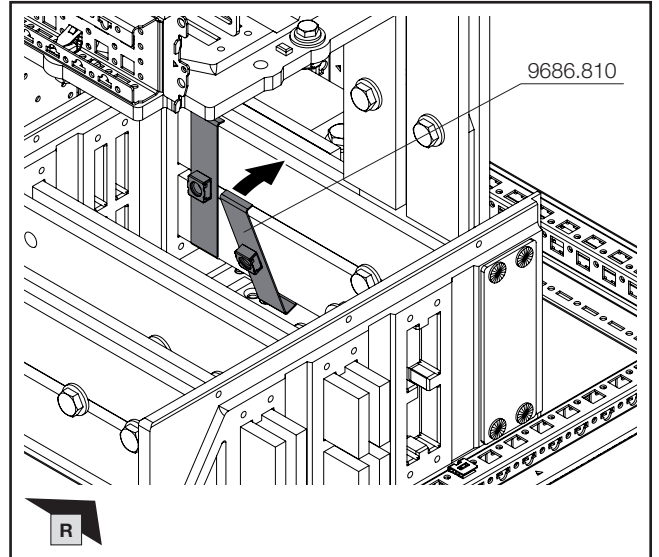
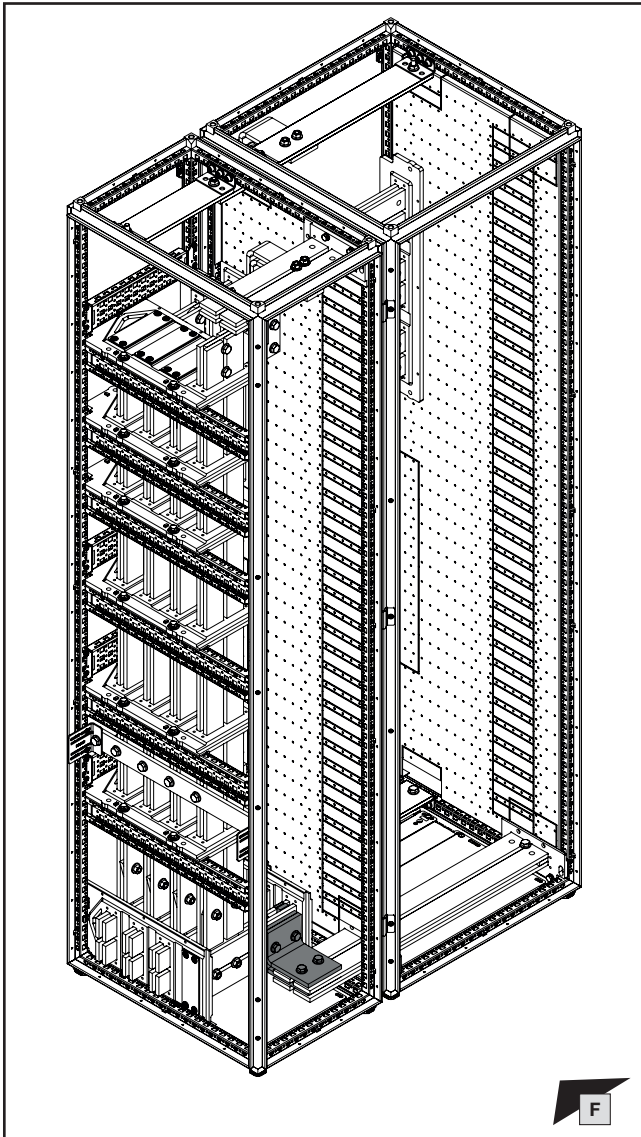

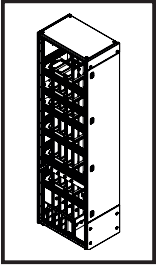

4. Modulare Frontgestaltung
 4. Modular front design
 4. Aménagement modulaire de la face avant

- 4.1 Montage Flachteile und Dachblech
- 4.1 Fitting the panels and roof plate
- 4.1 Montage des pièces plates et du toit

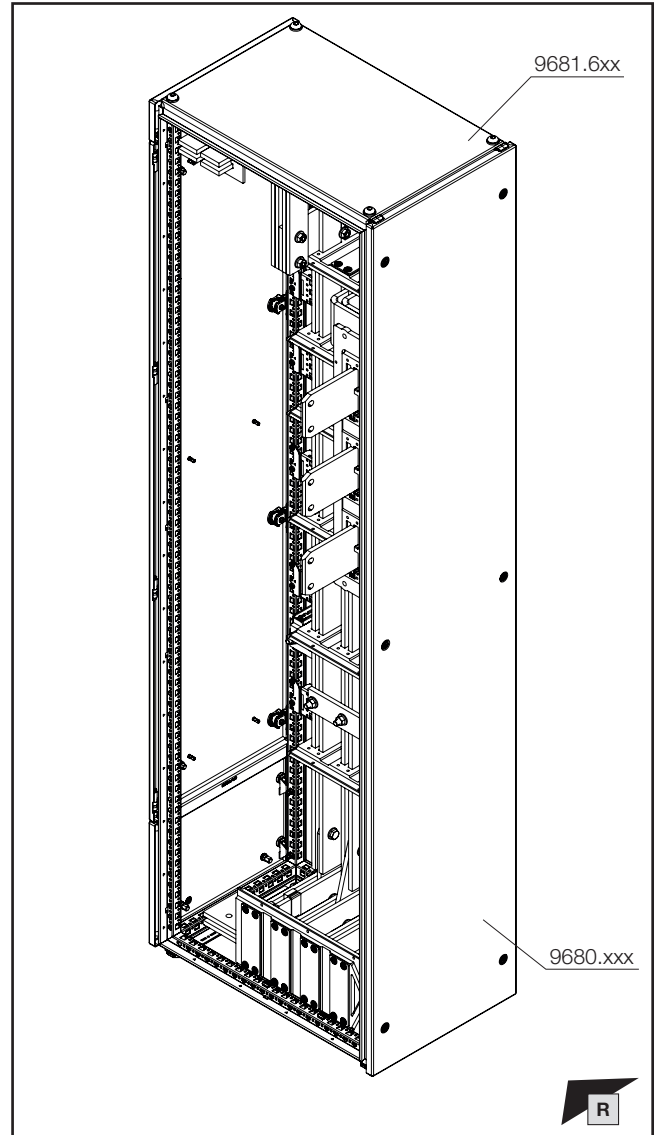
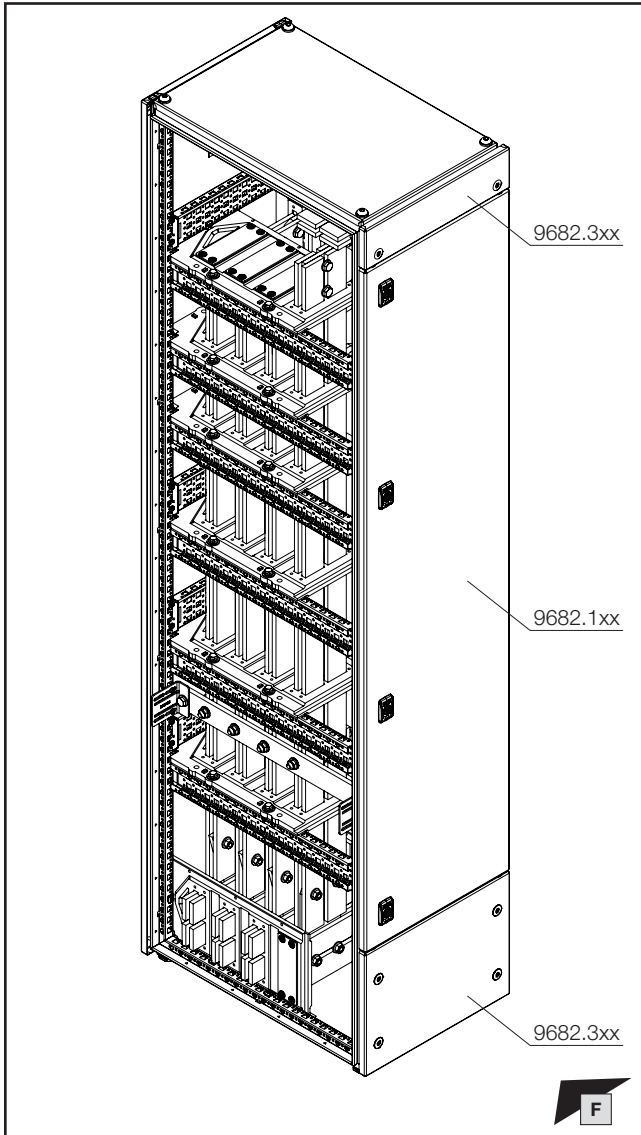

Hinweis / Note / Remarque

Beachten Sie für die abschließenden Arbeiten (Montage Flachteile, Frontgestaltung) je nach verwendetem Schrank die Beschreibungen in folgenden Anleitungen.

For the final work (fitting the panels, designing the front), please refer to the descriptions in the following instructions, depending on the enclosure used.

Pour les travaux finaux (montage des pièces plates, aménagement de la face avant), veuillez tenir compte, en fonction de l'armoire utilisée, des indications dans les notices suivantes.

Anreih-Schranksystem VX25
 Enclosure baying system VX25
 Armoires juxtaposables VX25

 DE/EN/FR

Modulare Frontgestaltung VX25
 Modular front design VX25
 Aménagement modulaire de la face avant VX25

 DE/EN/FR

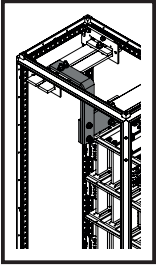

SW16/
SW17

DE EN FR



5. Besonderheit Sammelschienensystem 2 x 50 x 10
5. Particular feature – busbar system 2 x 50 x 10
5. Caractéristiques particulières – jeu de barres avec 2 barres de courant 50 x 10

- 5.1 Montage des N-Sammelschienensystems
- 5.1 Fitting the N busbar system
- 5.1 Montage des jeux de barres Neutre

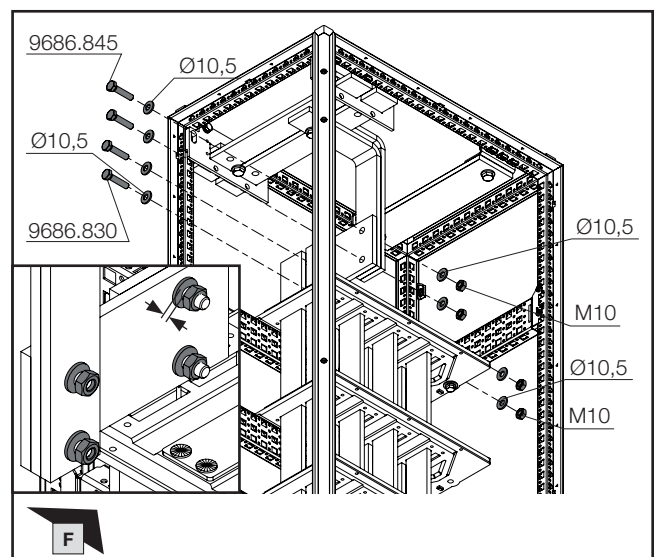
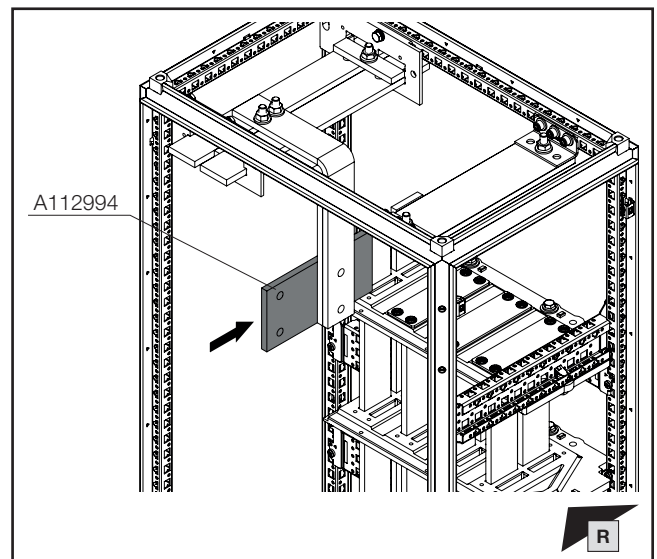
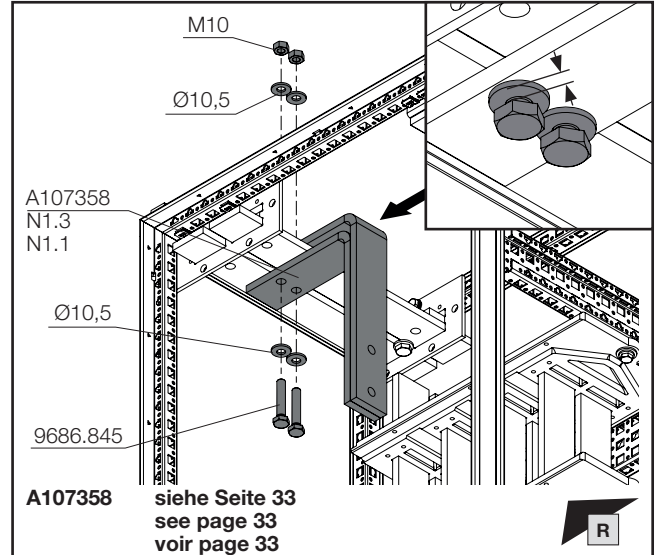
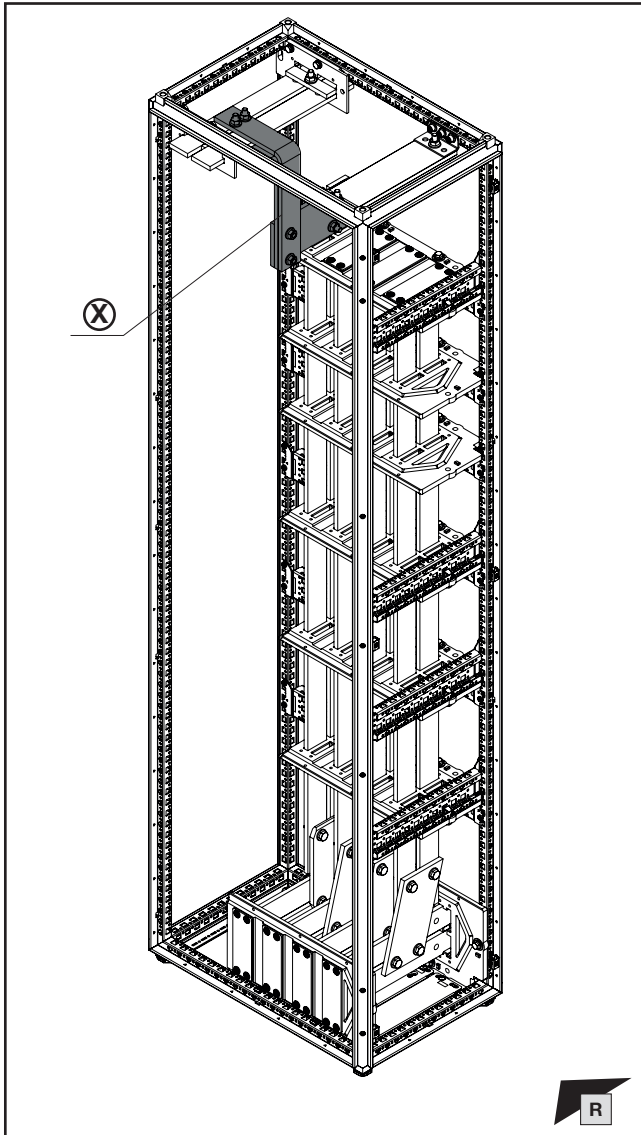

Hinweis / Note / Remarque (X)
 Vorbereitung der Anschlusswinkel: siehe Kapitel 1.10,
 Seite 33
 Preparing the connection brackets: see chapter 1.10,
 page 33
 Préparation des équerres de raccordement : voir
 chapitre 1.10, page 33

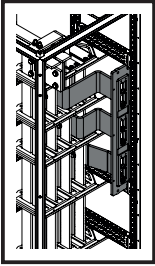

SW16/
SW17

DE EN FR



- 5. Besonderheit Sammelschienensystem 2 x 50 x 10
- 5. Particular feature – busbar system 2 x 50 x 10
- 5. Caractéristiques particulières – jeu de barres avec 2 barres de courant 50 x 10

- 5.2 Montage des vertikalen Hauptschienensystems und der Anreihverbinder
- 5.2 Fitting the vertical main busbar system and the baying connectors
- 5.2 Montage des jeux de barres principaux verticalement et des attaches de juxtaposition

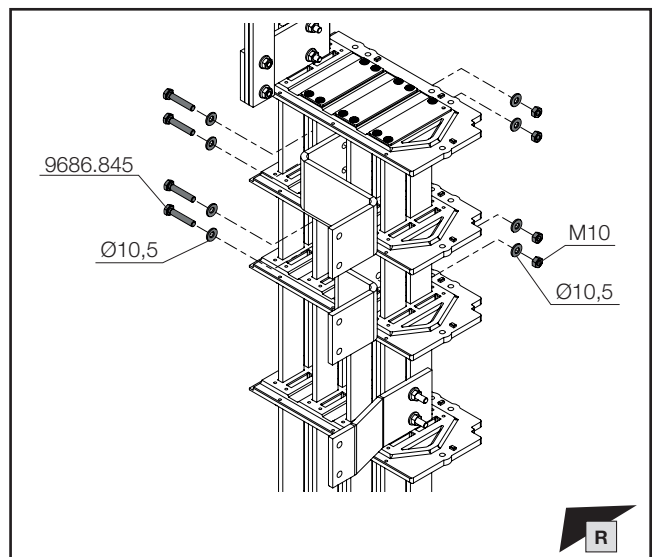
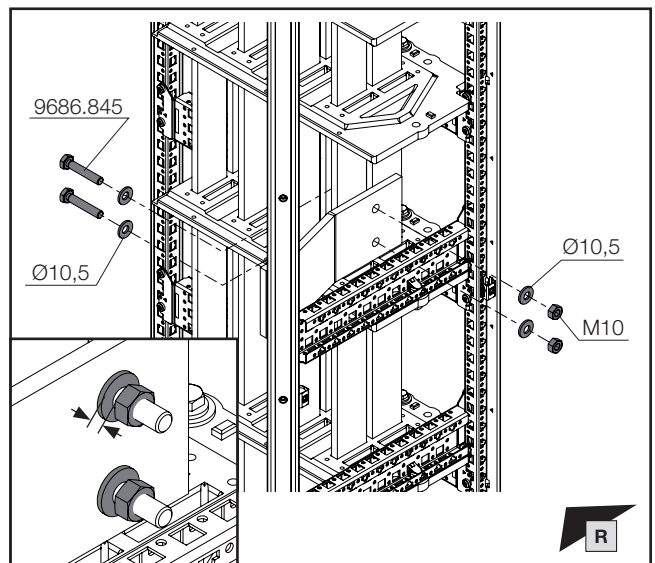
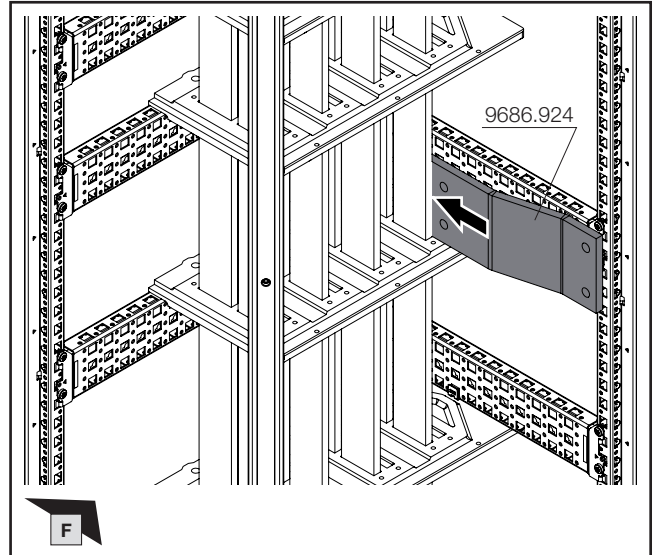
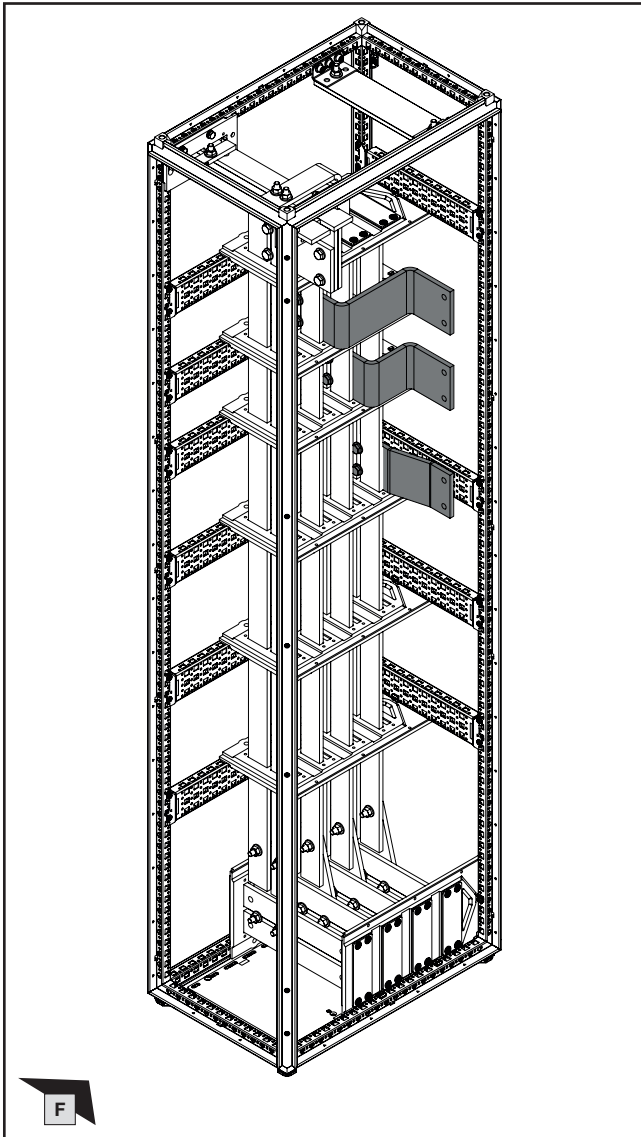

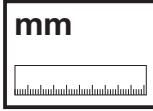
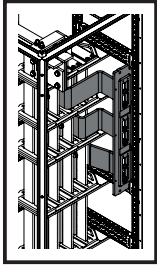

DE EN FR



- 5. Besonderheit Sammelschienensystem 2 x 50 x 10
- 5. Particular feature – busbar system 2 x 50 x 10
- 5. Caractéristiques particulières – jeu de barres avec 2 barres de courant 50 x 10

- 5.2 Montage des vertikalen Hauptschienensystems und der Anreihverbinder
- 5.2 Fitting the vertical main busbar system and the baying connectors
- 5.2 Montage des jeux de barres principaux verticalement et des attaches de juxtaposition

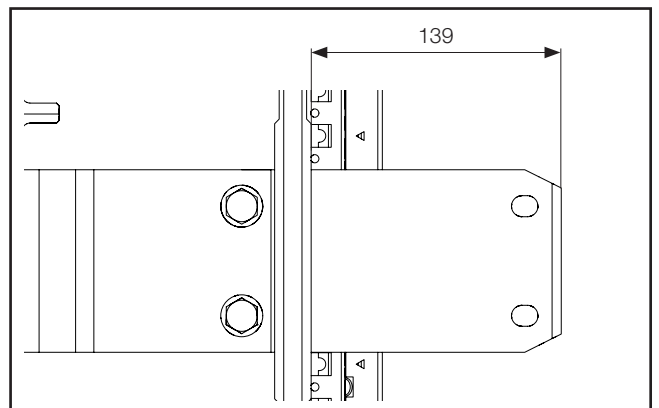
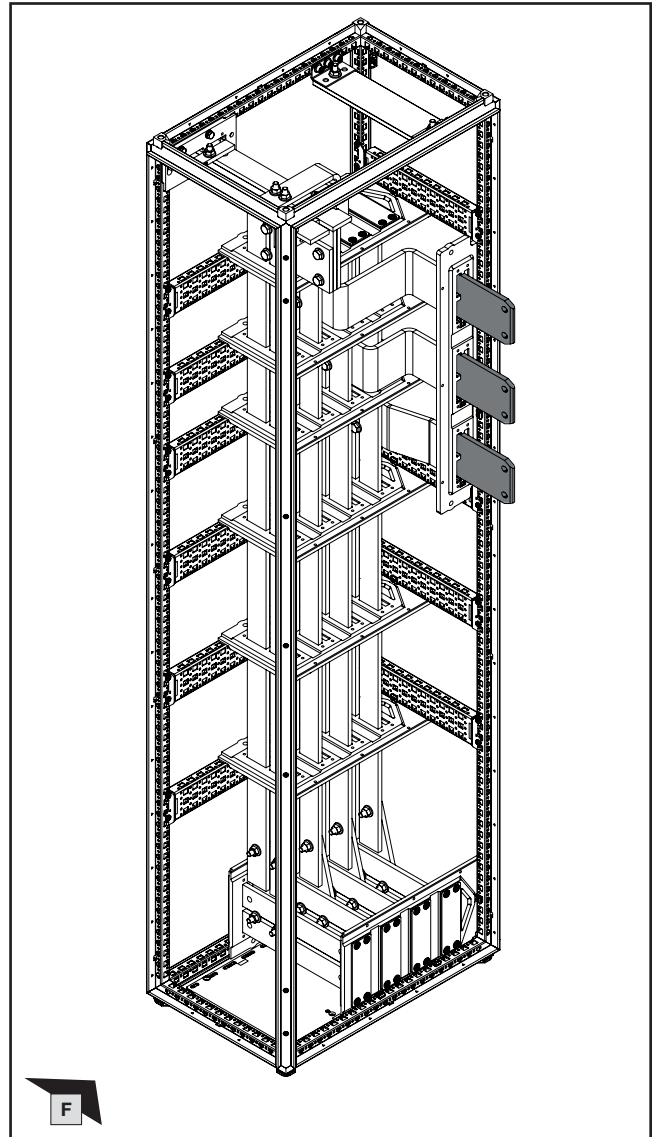
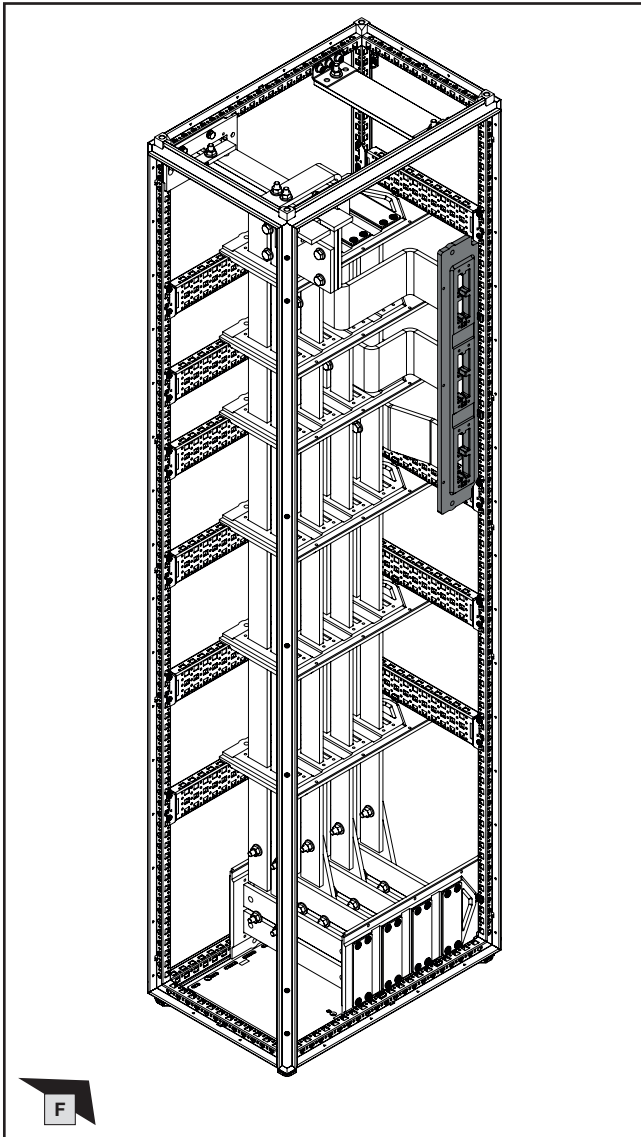

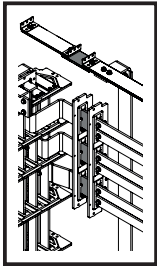

- 5. Besonderheit Sammelschienensystem 2 x 50 x 10
- 5. Particular feature – busbar system 2 x 50 x 10
- 5. Caractéristiques particulières – jeu de barres avec 2 barres de courant 50 x 10

- 5.3 Verbindung Hochführungsfeld und Feld Rückbereich
- 5.3 Connecting the riser section and the rear area section
- 5.3 Raccordement zone de cheminement vertical et zone à l'arrière

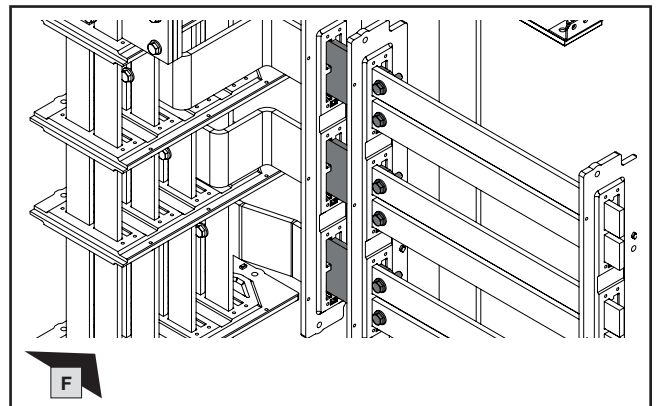
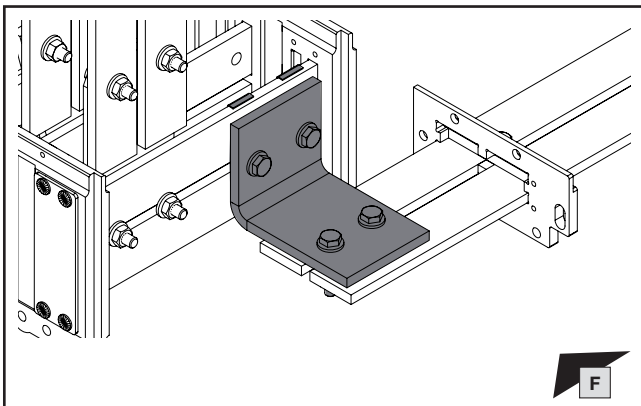
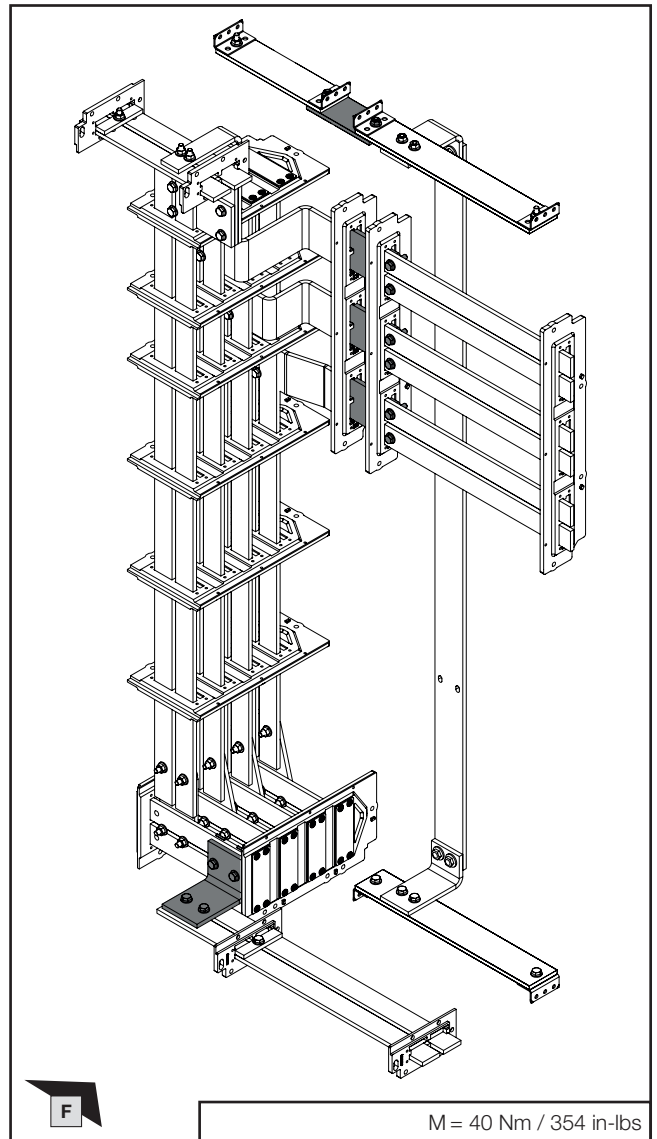
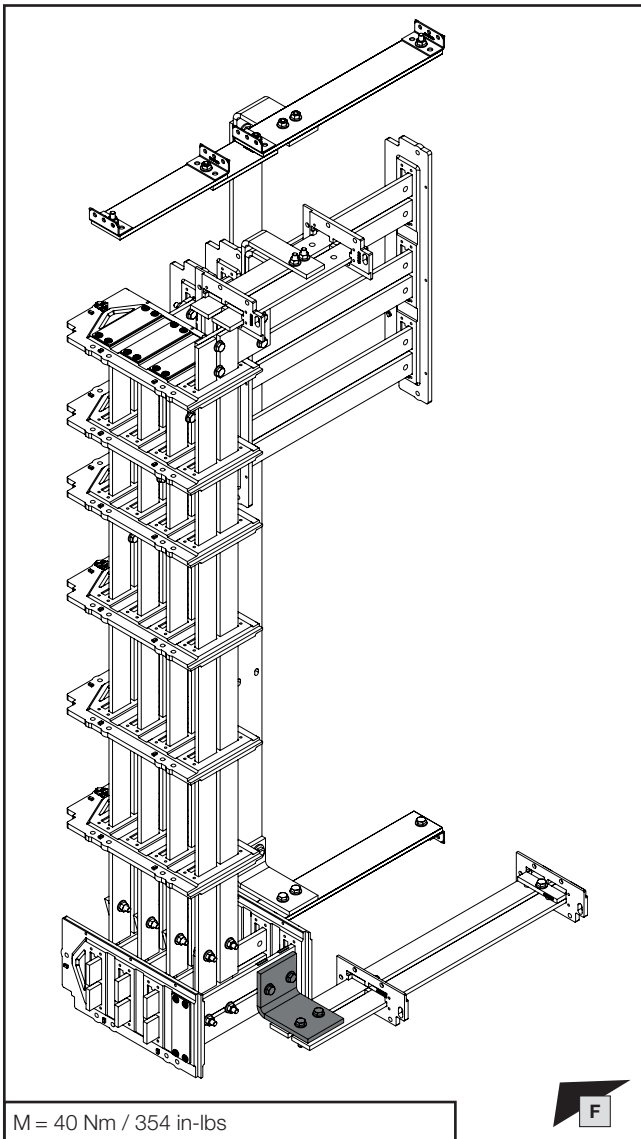

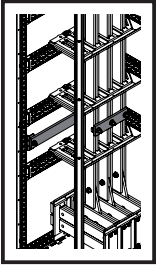

DE EN FR



6. **Besonderheit Hauptsammelschienensystem als 4-poliges System**
 6. **Particular feature – Main busbar system as a 4-pole system**
 6. **Caractéristique particulière – jeu de barres principal tétrapolaire**

- 6.1 **Montage des Stabilisators**
 6.1 **Fitting the stabiliser**
 6.1 **Montage du stabilisateur**

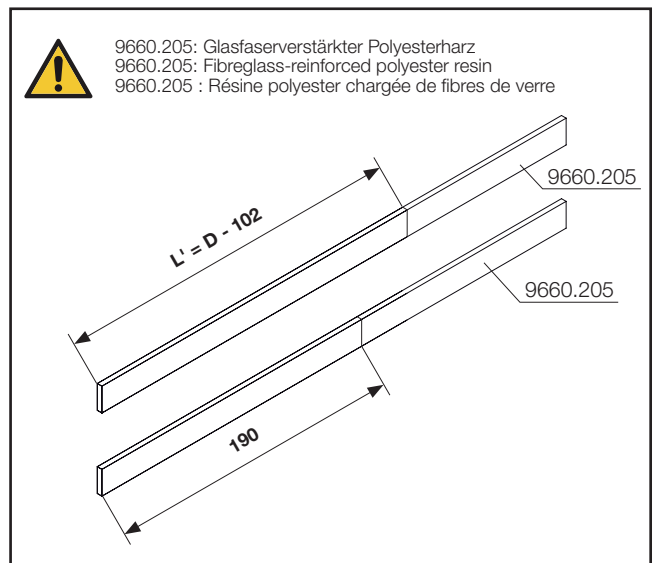
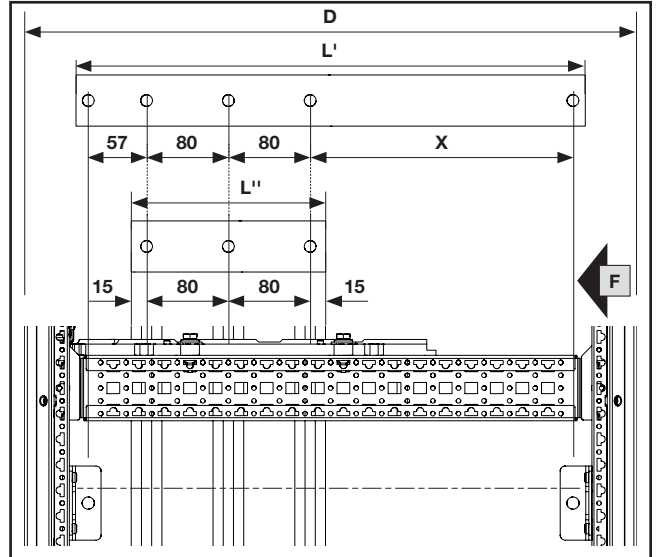
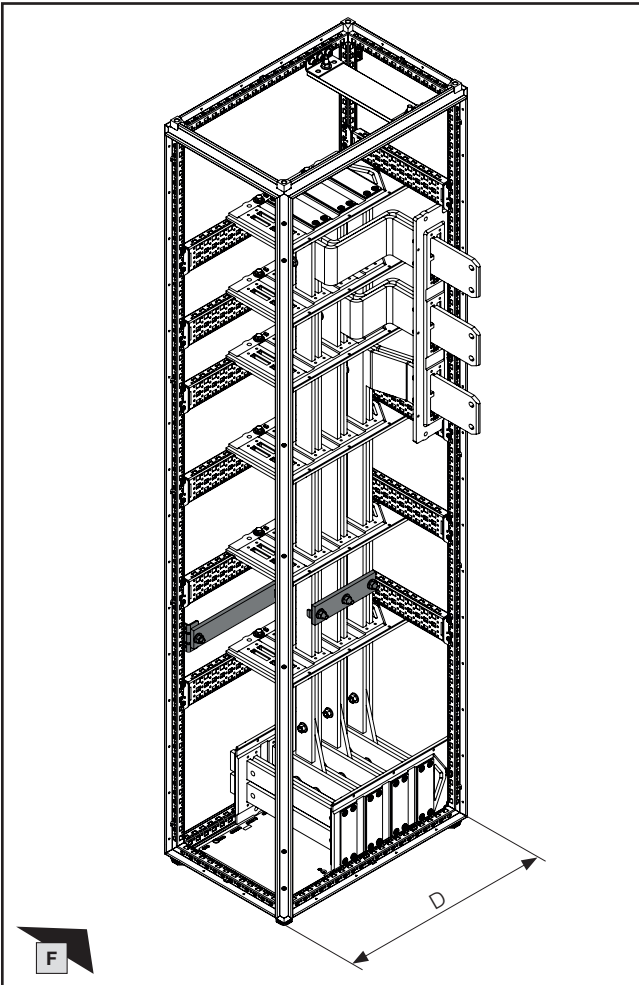

A 1 x

B 1 x

X mm	Tiefe D mm Depth D mm Profondeur D mm
257	600
457	800

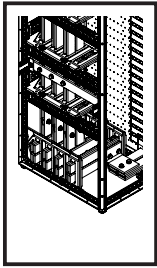

DE EN FR



- 6. Besonderheit Hauptsammelschienensystem als 4-poliges System
- 6. Particular feature – Main busbar system as a 4-pole system
- 6. Caractéristique particulière – jeu de barres principal tétrapolaire

- 6.2 Montage des N-Sammelschienensystems
- 6.2 Fitting the N busbar system
- 6.2 Montage des jeux de barres Neutre

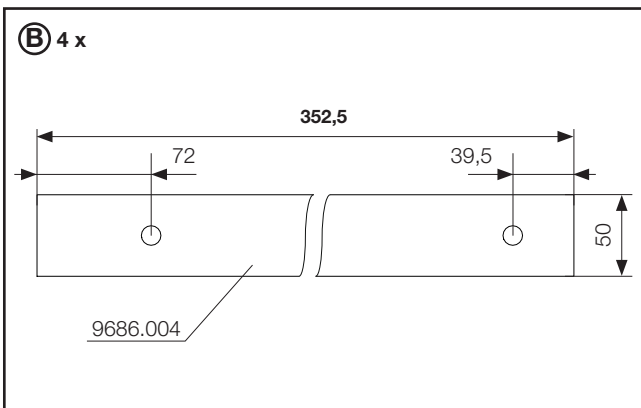
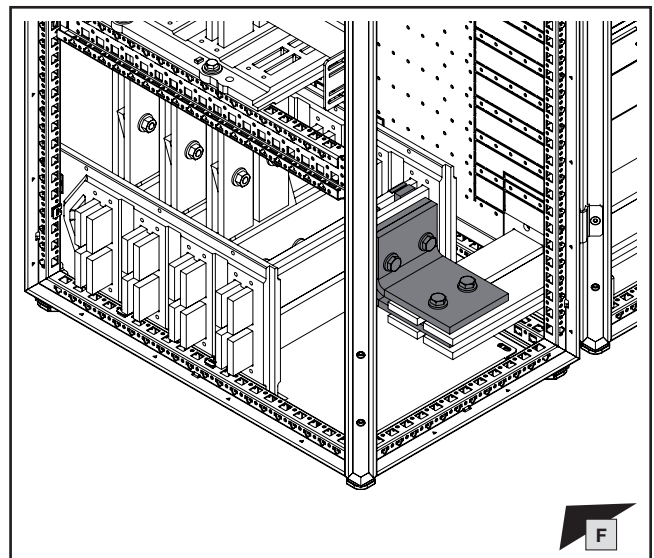
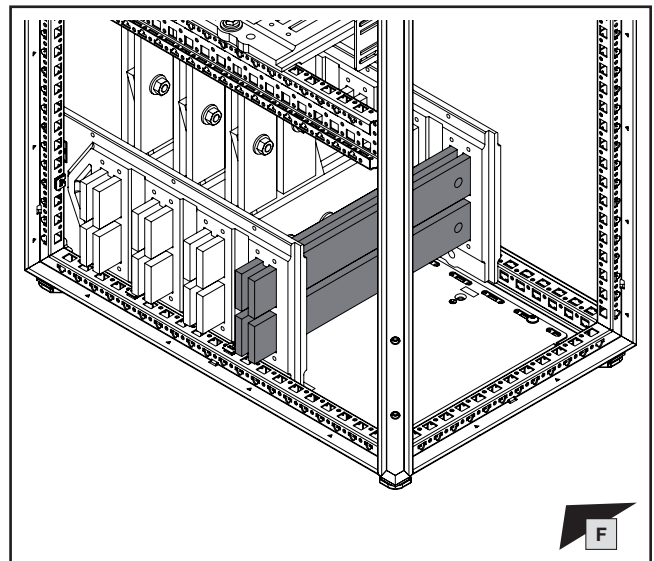
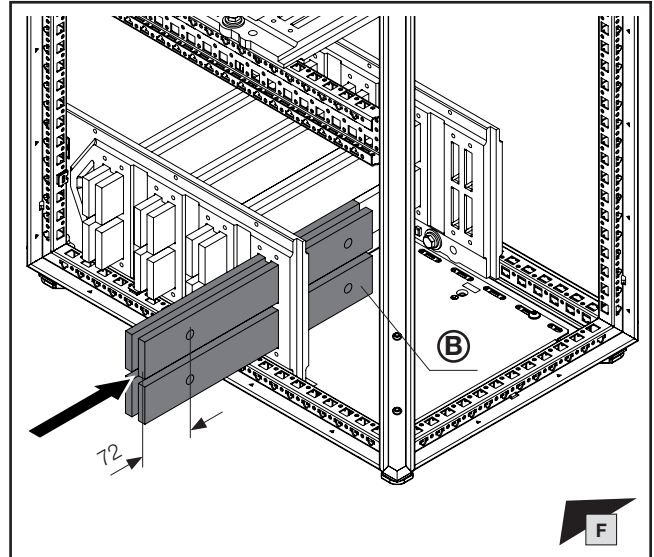
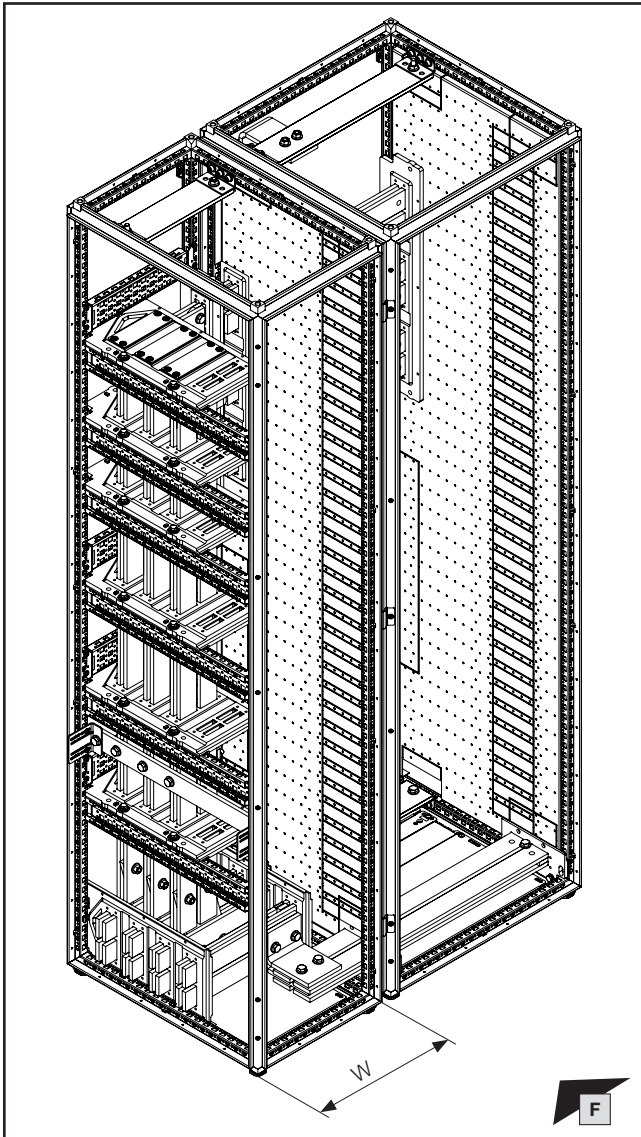

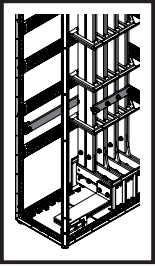

- 7. Besonderheit 800 mm Schranktiefe (Übersicht)
- 7. Particular feature – 800 mm enclosure depth (overview)
- 7. Caractéristique particulière – profondeur d'armoire de 800 mm (vue d'ensemble)

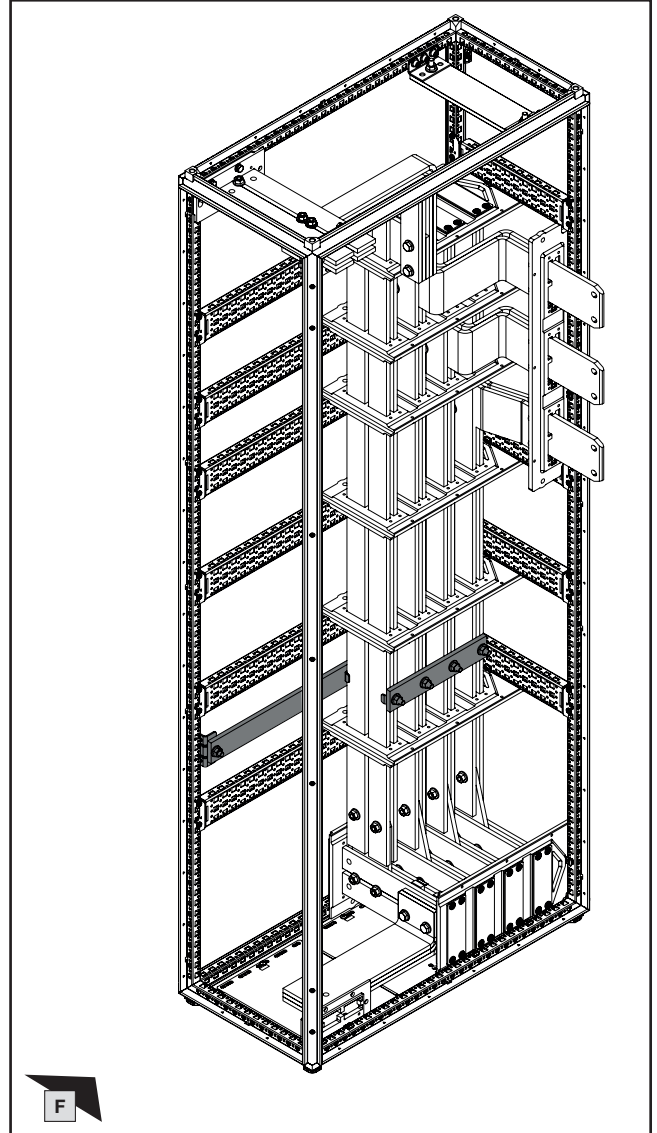
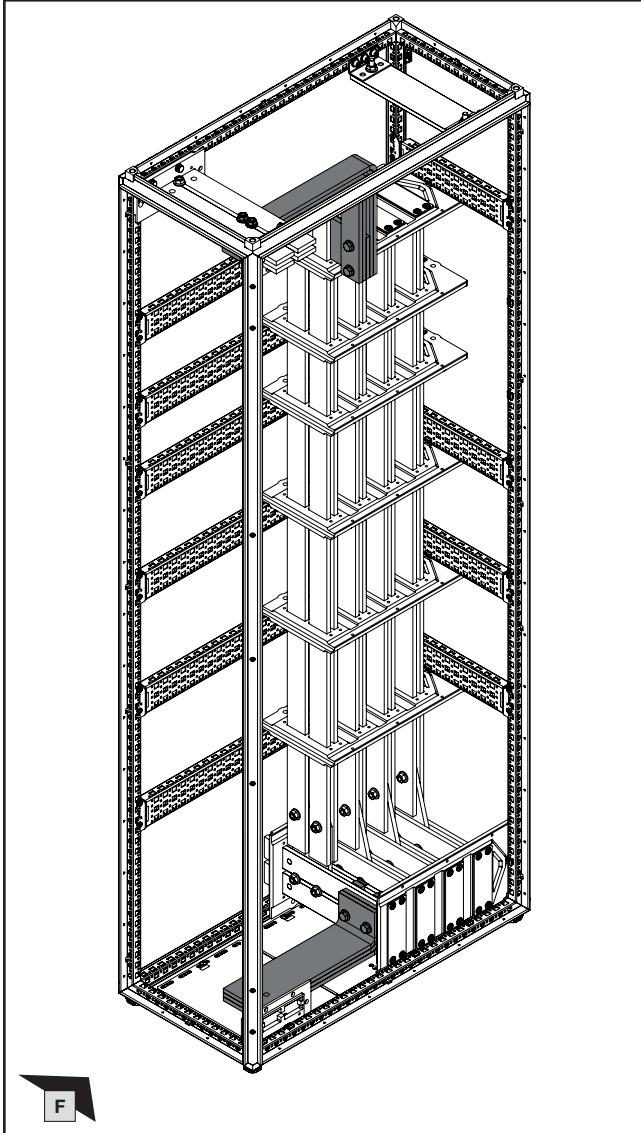

Hinweis / Note / Remarque (X)
Vorbereitung der oberen Anschlusswinkel N: siehe Kapitel 1.10, Seite 33
Preparing the upper N connection bracket: see chapter 1.10, page 33
Préparation des équerres de raccordement Neutre supérieures : voir chapitre 1.10, page 33



Hinweis / Note / Remarque (X)
Vorbereitung der Stabilisatoren: siehe Kapitel 1.13, Seite 39
Preparing the stabilisers: see chapter 1.13, page 39
Préparation des stabilisateurs : voir chapitre 1.13, page 39



Hinweis / Note / Remarque (X)
Vorbereitung der unteren Anschlusswinkel N: siehe Kapitel 3.4, Seite 63
Preparing the lower N connection bracket: see chapter 3.4, page 63
Préparation des équerres de raccordement Neutre inférieures : voir chapitre 3.4, page 63

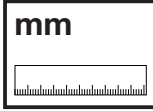
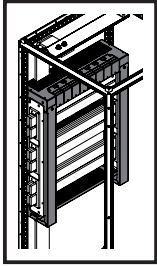

DE EN FR



- 8. Besonderheit Ausschnitt Form 2b
- 8. Particular feature – Cut-out for Form 2b
- 8. Caractéristique particulière – découpe forme 2b

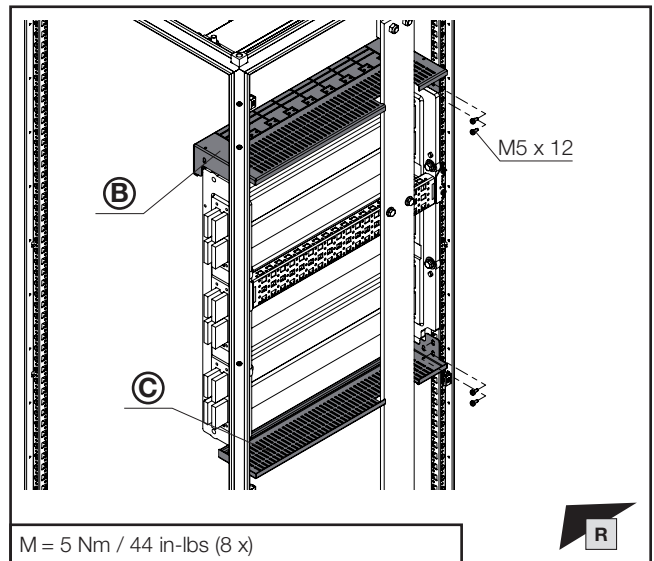
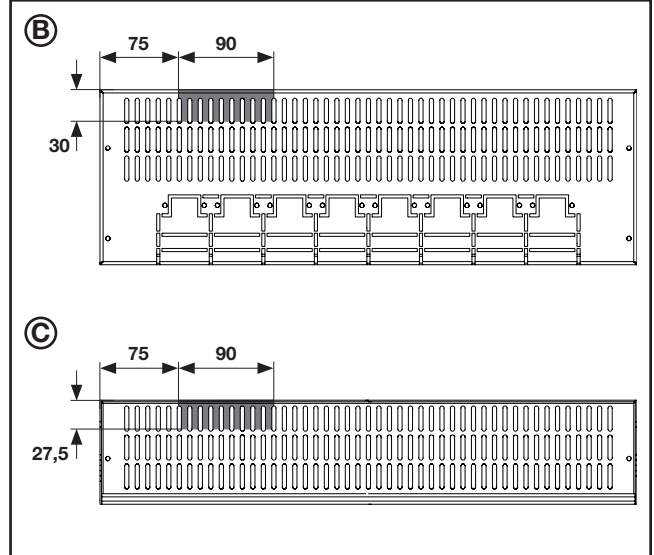
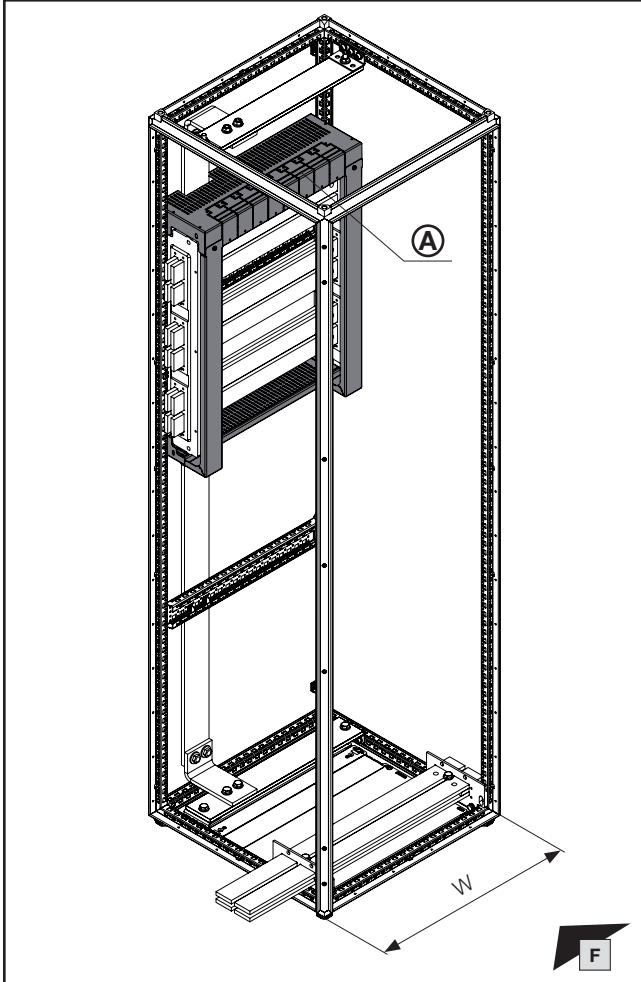

Schrankbreite W mm Enclosure width W mm Largeur d'armoire W mm	A Best.-Nr. Model No. Référence
600	9684.960
800	9684.980
1000	9684.900
1200	9684.920

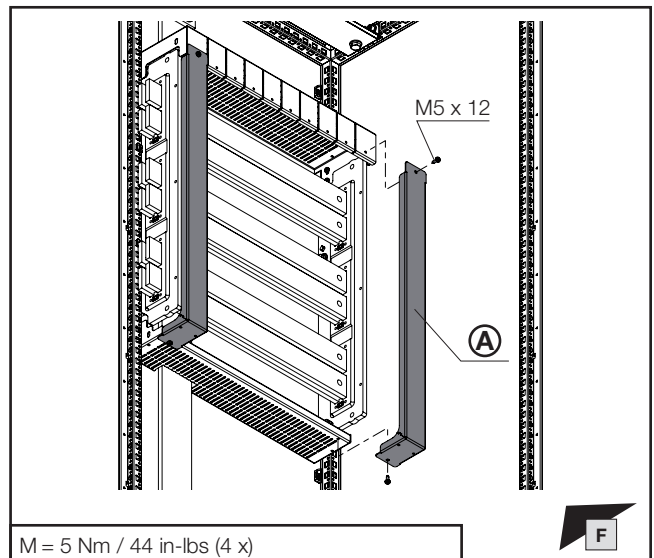
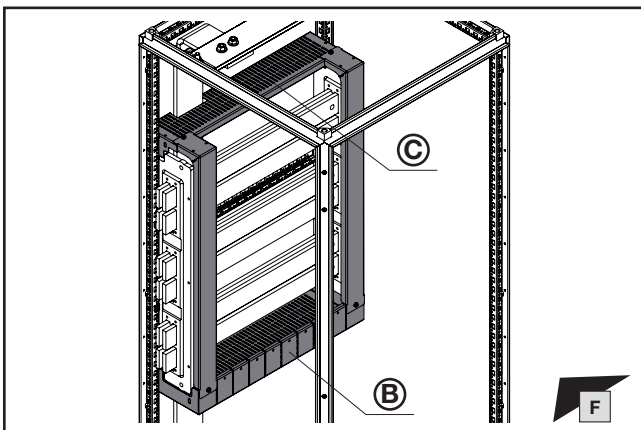

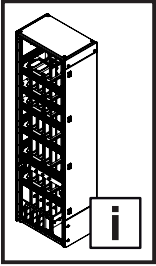

Artikelverzeichnis
List of model numbers
Liste des références

Best.-Nr. Model No. Référence	Kapitel Chapter Chapitre
3588.005	2.3
3591.060	2.2
4165.500	1.4 1.5 1.8 1.11 2.2 2.4
8617.110	1.3 1.8 2.2
8617.130	1.3 1.8 2.2
8617.140	1.3 1.8 2.2
8617.150	2.2
8617.160	2.2
8617.502	3.2
8686.845	1.12
9660.205	1.13 6.1
9676.017	1.13
9680.406	1.2
9680.408	1.2
9680.426	1.2
9680.428	1.2
9681.646	4.1
9681.648	4.1
9682.152	4.1
9682.154	4.1
9682.156	4.1
9682.158	4.1
9682.314	4.1
9682.324	4.1
9682.344	4.1
9682.354	4.1
9684.004	1.5 2.4
9684.006	2.4
9684.008	2.4
9684.010	2.4
9684.012	2.4
9684.900	8
9684.920	8
9684.960	8
9684.980	8
9686.004	1.10
9686.030	1.5

Best.-Nr. Model No. Référence	Kapitel Chapter Chapitre
9686.040	1.4 1.5 1.8
9686.060	1.11 2.4
9686.070	2.4
9686.080	1.5 1.8
9686.250	1.7 1.10 1.12 5.1
9686.300	1.10 2.3
9686.350	1.9
9686.495	1.13
9686.524	1.9
9686.534	1.9
9686.544	1.9
9686.580	2.2
9686.582	2.2
9686.584	1.9 2.2
9686.586	2.2
9686.588	2.2
9686.810	3.4
9686.816	1.13
9686.820	1.10 2.3 3.4
9686.830	1.10 2.2 2.3
9686.845	1.7 1.10 2.3 5.2
9686.855	1.10 3.4
9686.865	1.11 3.4
9686.924	1.6 1.7 1.11 5.2

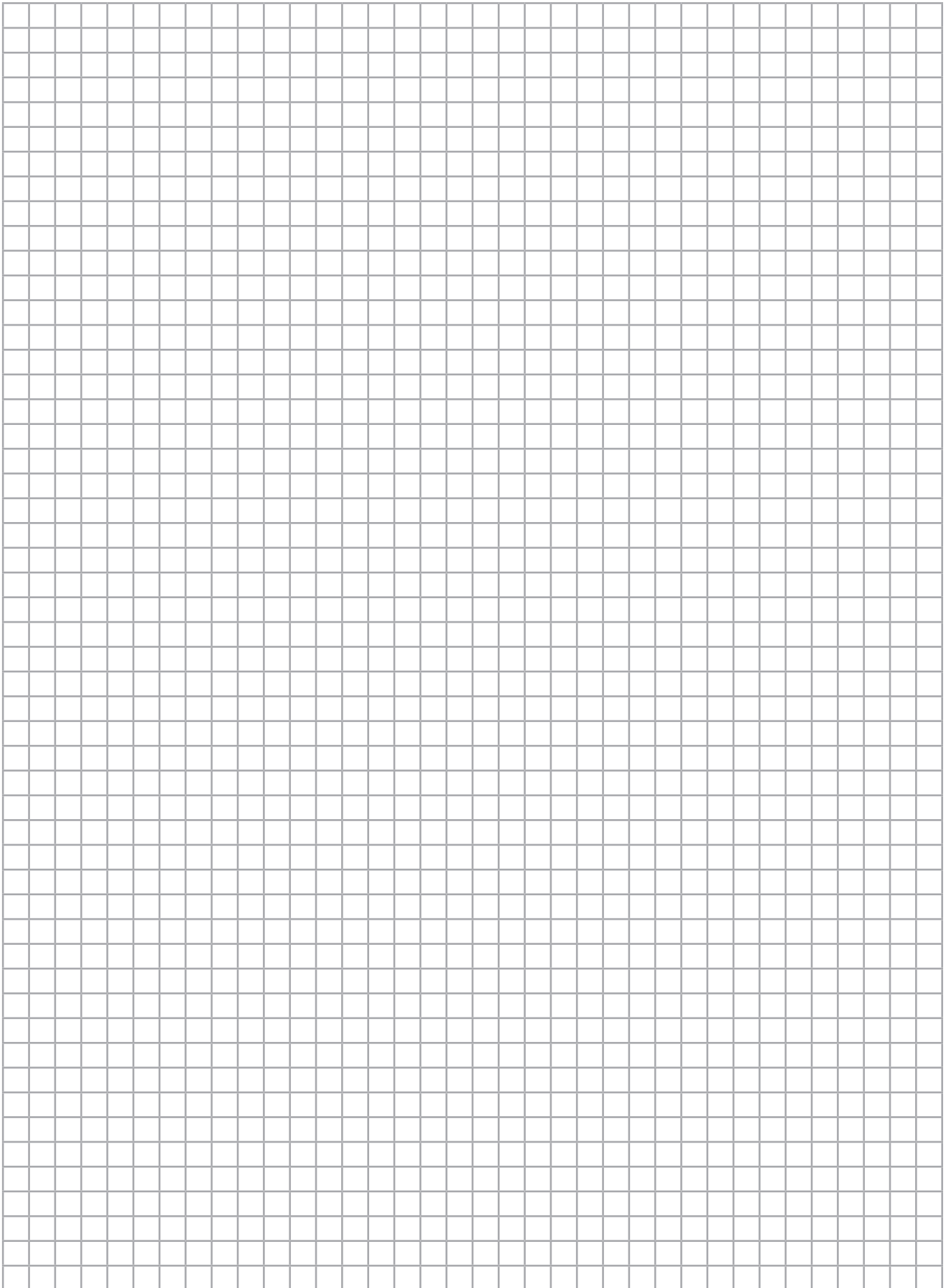

Rittal – The System.

Faster – better – everywhere.

- Enclosures
- Power Distribution
- Climate Control
- IT Infrastructure
- Software & Services

You can find the contact details of all Rittal companies throughout the world here.



www.rittal.com/contact

RITTAL GmbH & Co. KG
Auf dem Stuetzelberg · 35745 Herborn · Germany
Phone +49 2772 505-0
E-mail: info@rittal.de · www.rittal.com

08.2025/D-0000-00003281-02

ENCLOSURES

POWER DISTRIBUTION

CLIMATE CONTROL

IT INFRASTRUCTURE

SOFTWARE & SERVICES



FRIEDHELM LOH GROUP