

Rittal – The System.

Faster – better – everywhere.

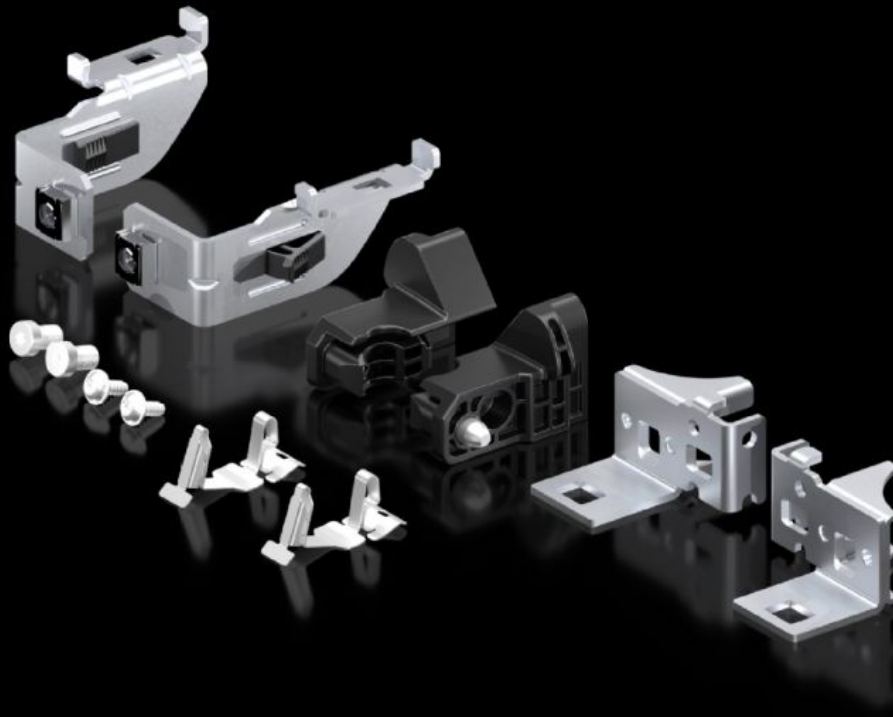

VX 5050.816 Montageplåtsfastsättning

State: 2026-03-14 (Source: [rittal.com/se-sv](https://www.rittal.com/se-sv))

ENCLOSURES

POWER DISTRIBUTION

CLIMATE CONTROL

IT INFRASTRUCTURE

SOFTWARE & SERVICES

FRIEDHELM LOH GROUP



VX 5050.816 - Montageplåtsfastsättning för VX SE, SE, TP, PC, IW

Features

| | |
|-------------------|-------------|
| Art. nr. | VX 5050.816 |
| Förpackningsenhet | 1 st. |
| Nettovikt | 0,65 kg |
| Bruttovikt | 0,66 kg |
| Tullvarukod | 83024900 |